

## **PARTIAL SHADING DETECTION IN SOLAR SYSTEM USING SINGLE SHORT PULSE OF LOAD**

**Mateusz Bartczak**

Wrocław University of Technology, Chair of Electronic and Photonic Metrology, Bolesława Prusa 53/55, 50-317 Wrocław, Poland  
(✉ mateusz.bartczak@pwr.edu.pl, +48 513 390 725)

### **Abstract**

A single photovoltaic panel under uniform illumination has only one global maximum power point, but the same panel in irregularly illuminated conditions can have more maxima on its power-voltage curve. The irregularly illuminated conditions in most cases are results of partial shading. In the work a single short pulse of load is used to extract information about partial shading. This information can be useful and can help to make some improvements in existing MPPT algorithms. In the paper the intrinsic capacitance of a photovoltaic system is used to retrieve occurrence of partial shading.

Keywords: maximum power point, partial shading, load pulse, test station, I–V curve.

© 2017 Polish Academy of Sciences. All rights reserved

### **1. Introduction**

A growing demand for energy, especially electricity, ensuring security of supply and reducing undesired effects of climate-related emissions of carbon dioxide and other pollutants resulting from combustion of fossil fuels into the atmosphere is one of the biggest economic and environmental challenges in the world in recent years. Today, the solar energy production is one of the fastest growing industries in the world and one of the fastest growing energy technologies [1]. All these processes stimulate the development of new techniques.

One of the major challenges in *photovoltaic* (PV) systems is increasing the amount of produced energy. The shape of I–V curve depends on many factors, like temperature, spectral irradiance, total irradiance, orientation to the light source, type of bypass, parasitic impedances (due to a length of cable bundles between a test station and modules), mechanical aspects, optical alignment effects. Partial shading is a serious problem and leads to lowering the efficiency of produced energy. There are several papers that describe how large is the impact of this phenomenon on the amount of produced energy [2, 3]. The authors of [4] present a MATLAB-based modelling and simulation scheme suitable for studying the I–V and P–V characteristics of a PV array under a non-uniform insolation due to partial shading. In most cases, from a hardware point of view, partial shading is handled by bypass diodes, however a method described in [5] slightly increases the efficiency of photovoltaic module by replacing bypass diodes with FET transistors of a low drain-source resistance. This solution reduces energy losses caused by the current flowing over the bypass. From a software point of view, we can find a lot of direct and indirect algorithms searching the *maximum power point* (MPP) [6]. Most of them are inappropriate to track MPP in partially shaded conditions, because the photovoltaic array characteristic curves exhibit multiple local maxima. In the literature, the most popular is a *perturb and observe* (P&O) algorithm. This approach is often used because of its simple implementation. On the other hand, a drawback of this method is its low efficiency in fast changing insolation conditions. The authors of [9, 10] expand a standard solar

system with installing additional temperature and light sensors. They also propose a hybrid of P&O and open-voltage algorithms. Those sensors improve the system immunity for conditions of partial shading in comparison with the reference P&O method. One of the drawbacks of this solution is an additional wiring necessary to measure the temperature and irradiance.

The paper concentrates on a method dedicated to detection of partial shading conditions. The obtained results can be useful for improvement of the MPPT algorithms. The proposed method is based on analysis of the system response to a short load pulse. This work was inspired by [5, 6], where short pulses of light are used to acquire the I–V curve, and also by a load-pulse method used in power plants to measure the system impedance.

In the literature, a drawback caused by the intrinsic parasitic capacitance is generally neglected, but we can find MPPT algorithms which are strictly based on this property of a PV cell. For example, the authors of [7] developed a method similar to the incremental conductance [11] procedure, which additionally includes the parasitic capacitance. Fig. 1 shows a response of a solar system to a single short pulse of load; in this case it was a short current pulse. The curves from Fig. 1 have been plotted for the measurement setup described later in this paper. As can be concluded from Fig. 1, the smaller insolation, the higher the capacitance of PV system.

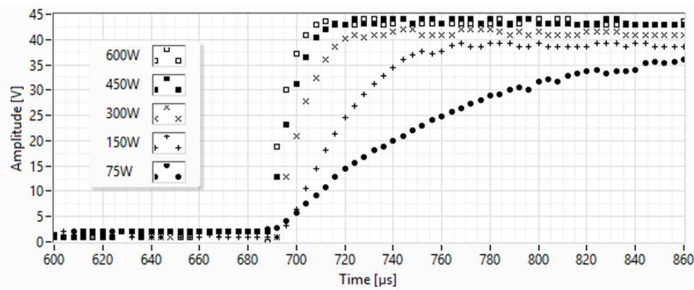

Fig. 1. A response to a short load pulse for different insolation conditions.

The rise of capacitance caused by a lower insolation can be used for detection of partial shading in a system of PV cells. Fig. 2 shows a system of two STP010-12/Kb (SUNTECH) solar panels connected in series (Table 1 gives its electrical characteristics). These panels have no additional bypass diodes but consist of 36 cells connected in series. Both solar panels are bypassed by diodes. When both panels operate in the same environmental conditions, *i.e.* the same insolation, the system response looks like one plot from Fig. 1. When insolation conditions are different for each panel then the output of both panels is the sum of their individual responses. Fig. 3 shows individual responses of each panel. As can be seen from the chart, the PV panel which is partially shaded needs more time to restore its operating voltage. Fig. 4 compares two plots – the first one is calculated as the sum of responses, whereas the second one is the response measured for both panels.

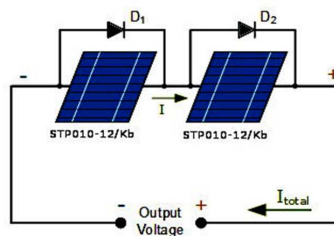

Fig. 2. Two STP010-12/Kb panels connected in series and bypass diodes.

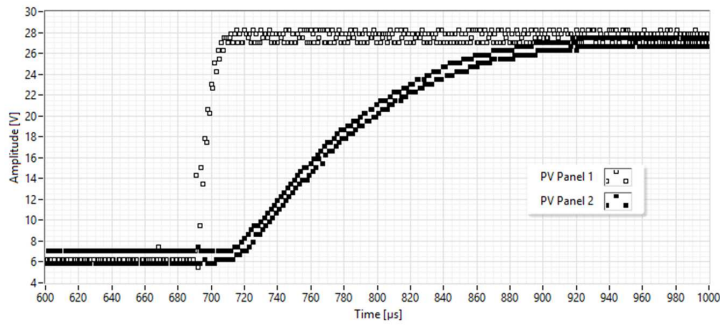

Fig. 3. The PV Panel 1 response for full insolation and the PV Panel 2 response for partly shaded conditions.

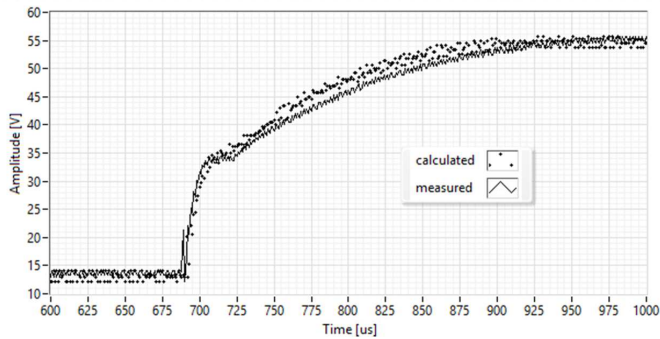

Fig. 4. The calculated and measured responses in partial shading.

Table 1. Parameters of solar panels used in the experiment.

Model Number	STP010–12/Kb
Rated Maximum Power ( $P_{MAX}$ )	10 W
Output Tolerance	$\pm 10 \%$
Current at $P_{max}$ ( $I_{MP}$ )	0.57 A
Voltage at $P_{max}$ ( $V_{MP}$ )	17.4 V
Short-Circuit Current ( $I_{OC}$ )	0.65 A
Open-Circuit Voltage ( $V_{OC}$ )	21.6 V
Nominal Operating Cell Temp. ( $T_{NOCT}$ )	$45^{\circ}\text{C} \pm 2^{\circ}\text{C}$

## 2. Experimental setup

Figure 5 shows a simplified overview of the measurement workstation which has been used during the experiment. The setup consists of a PC with LabVIEW application, a load controller, a source of light and an oscilloscope. The LabVIEW application communicates with the load controller and the oscilloscope (Rigol D1054Z) via USB connection. The PC application, using the load controller, can set the operating voltage of solar panel and monitor the current. The test station is designed to measure the I–V curve and also to observe the response of PV system to a short load pulse. Short pulses of load are generated independently in a similar way as in the Short-Current Pulse-Base MPPT Method [8], but one change has been introduced in this setup, *i.e.* the possibility of regulating the current within the range from short-circuit to zero. Fig. 6 shows an example of the I–V curve and the power measured by the setup. The LabVIEW

software has been chosen for this experiment because it provides means for data acquisition (signal I/O), analysis and presentation, and it also supports communication between the measurement modules (*e.g.*: the oscilloscope, power supply, *etc.*). In the circuit, the load controller plays a similar role to the active load, which is based on an N-CHANNEL MOSFET transistor.

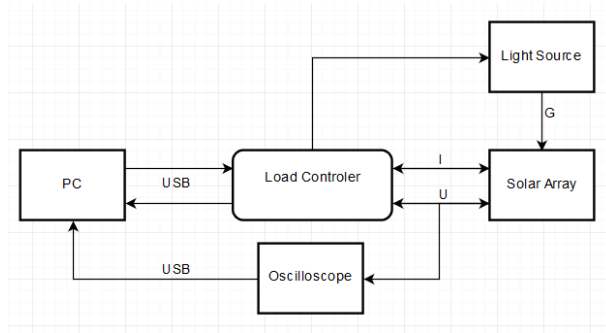

Fig. 5. A simplified scheme of measurement workstation used in the experiment.

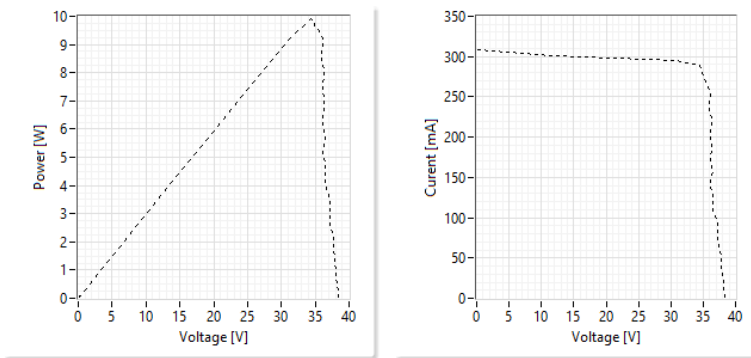

Fig. 6. Examples of curves measured in the PV system using the experimental setup: I–V curve (left), power curve (right).

### 3. Measurement results

As mentioned before, the measurements have been performed with the system (Fig. 2) consisting of two arrays of 36 solar cells connected in series. The module parameters are shown in Table 1. Every module is bypassed by a diode. Solar cells used in the experiment have a low capacitance, therefore the time required by the solar system to restore the operating voltage (when the load pulse is ended) is short. Fig. 7 shows a group of responses measured in various conditions of shading. One of the solar panels was fully exposed to irradiation, whereas the second one was gradually darkened, starting from the full exposure and ending in the complete blackout.

Successive Figs. 8–11 show the progressive darkening of one of the solar panels. The time required by a solar panel to restore its operating voltage is small for panels used in the experiment and is approximately equal to between 10  $\mu$ s and 100  $\mu$ s, depending on insolation conditions. The recovery time is counted starting from the moment of ending the load pulse to the moment of reaching a voltage level of  $V_{oc}$ . The higher capacitance of the solar system, the longer the recovery time. Fig. 12 shows the response of a 500 W system, which consists

of two 250 W panels, *i.e.* a  $2 \times 250$  W system. Thus, the time required to restore the operating voltage is approximately equal to 30 ms. When a level of insolation of two solar panels starts to be significantly inhomogeneous, the response shape starts to bend (Fig. 10 and Fig. 11). The fact of forming a bend in the response shape can be used for detecting a condition of partial shading. Fig. 13 shows plots of derivatives calculated for data from Figs. 8–11. A derivative has been approximated according to (1):

$$f'(x) = \frac{f(x+h) - f(x-h)}{2h} \quad (1)$$

The results for conditions of significant insolation inhomogeneity between PV panels are depicted in plots enclosed in the frame in Fig. 13. The details of their shapes can be analysed by searching data plots for peaks and valleys.

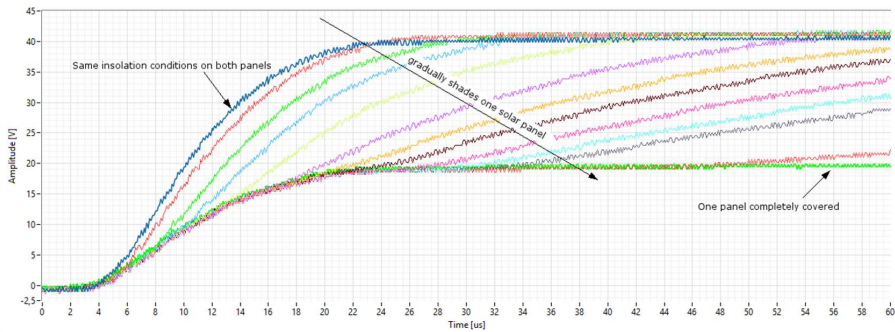

Fig. 7. A group of responses in various insolation conditions.

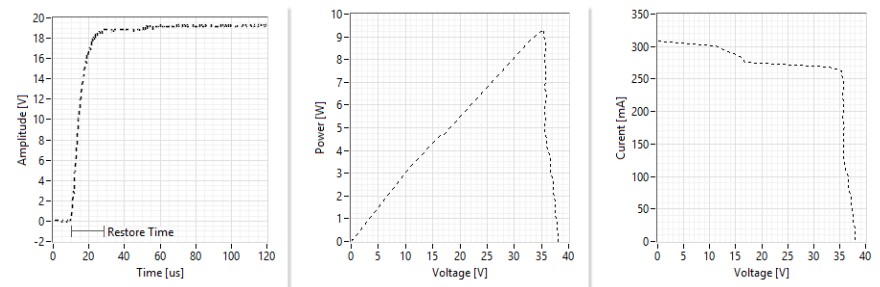

Fig. 8. The response to a short load pulse: voltage (left), power(middle), current – according to the measured I–V curve for partial shading conditions (right).

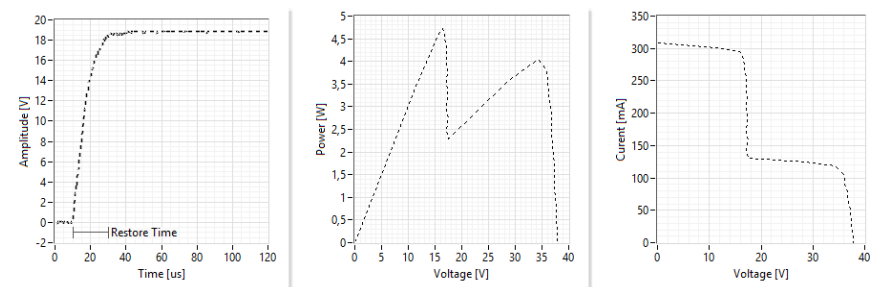

Fig. 9. The response to a short load pulse: voltage (left), power(middle), current – according to the measured I–V curve for partial shading conditions (right).

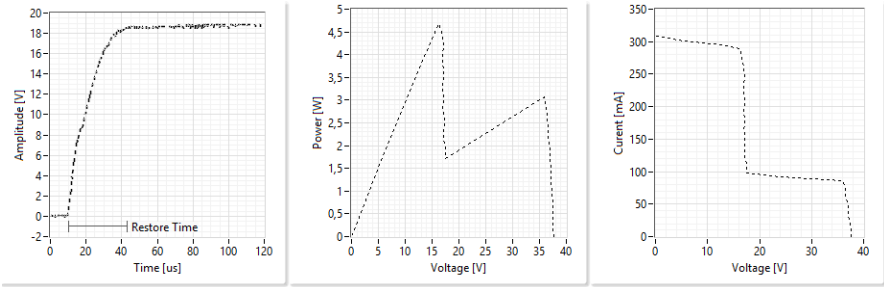

Fig. 10. The response to a short load pulse: voltage (left), power(middle), current – according to the measured I–V curve for partial shading conditions (right).

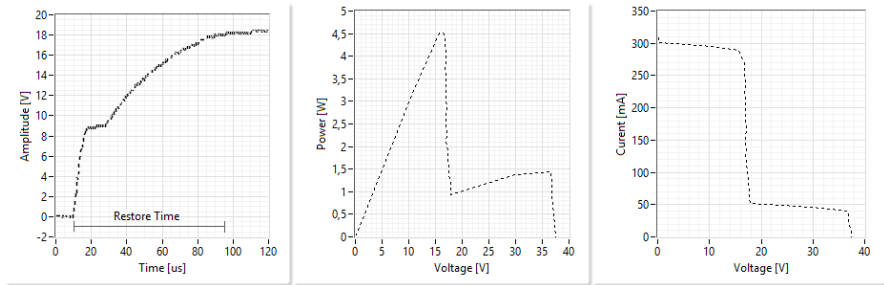

Fig. 11. The response to a short load pulse: voltage (left), power(middle), current – according to the measured I–V curve for partial shading conditions (right).

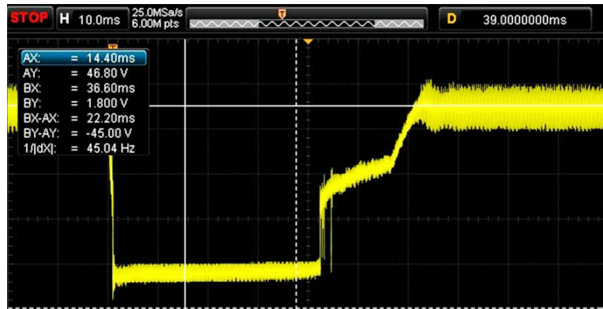

Fig. 12. The response to a short load pulse for a system consisting of larger solar panels.

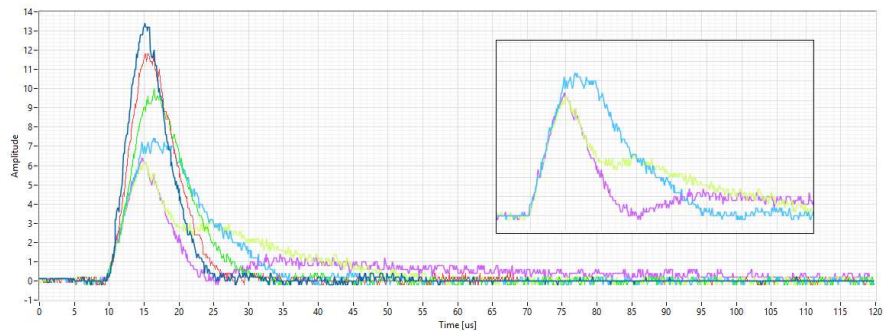

Fig. 13. Derivatives calculated from Fig. 8–11. In the highlighted frame the last three plots are obtained for significant disproportion in insolation between PV panels.

## 4. Conclusion

The paper reports on a short-load-pulse method dedicated to determination of partial shading conditions in PV power generation systems. The proposed approach identifies and exploits the relationship between partial shading and the response to a short load pulse. This mechanism can be used for improving selected MPPT algorithms or constructing a hybrid of existing approaches, e.g. P&O and Cuckoo Search (CS) algorithms. The P&O is inefficient in conditions of partial shading, whereas the Cuckoo Search exhibits better results in partial shading conditions, but requires more time for computations. Both of them can be combined, contributing to improved power generation in conditions of partial shading. Implementation of the methodology proposed in the paper does not require sophisticated electronic circuitry, so the measurement can be performed relatively easily. On the other hand, this approach shows also a drawback, because system interruptions have to be applied quite frequently.

## References

- [1] Auswertungstabellen zur Energiebilanz Deutschland 1990 bis 2014 (2016). *AG Energiebilanzen (AGEB)*, <http://www.ag-energiebilanzen.de/>.
- [2] Masoum, A.S., Padovan, F., Masoum, M.A.M. (2010). Impact of partial shading on voltage-and current-based maximum power point tracking of solar modules. *IEEE PES General Meeting*, 1–5.
- [3] Balasubramanian, I.R., Ganesan, S.I., Chilakapati, N. (2014). Impact of partial shading on the output power of PV systems under partial shading conditions. *IET Power Electronics*, 7(3), 657–666.
- [4] Hiren, P., Agarwal, V. (2008). MATLAB-based modeling to study the effects of partial shading on PV array characteristics. *IEEE transactions on energy conversion*, 23(1), 302–310.
- [5] d'Alessandro, V., Pierluigi, G., Santolo, S. (2014). A simple bipolar transistor-based bypass approach for photovoltaic modules. *IEEE Journal of Photovoltaics*, 4(1), 405–413.
- [6] Kojima, H., *et al.* (2014). Accurate and rapid measurement of high-capacitance PV cells and modules using a single short pulse light. *2014 IEEE 40th Photovoltaic Specialist Conference (PVSC)*. IEEE, 2014. *Survey of Maximum PPT techniques of PV Systems*, Nasr, A.A.A., Saied, M.H., Mostafa, M.Z., Abdel- Moneim, T.M.
- [7] Brambilla, A., *et al.* (1999). New approach to photovoltaic arrays maximum power point tracking. (1999). *Power Electronics Specialists Conference, PESC 99, 30th Annual IEEE*, 2.
- [8] Noguchi, T., Shigenori, T., Nakamoto, R. (2002). Short-current pulse-based maximum-power-point tracking method for multiple photovoltaic-and-converter module system. *IEEE Transactions on Industrial Electronics*, 49(1), 217–223.
- [9] Mroczka, J., Ostrowski, M. (2015). Maximum power point search method for photovoltaic panels which uses a light sensor in the conditions of real shading and temperature. *SPIE Optical Metrology. International Society for Optics and Photonics*.
- [10] Mroczka, J., Ostrowski, M. (2014). A hybrid maximum power point search method using temperature measurements in partial shading conditions. *Metrol. Meas. Syst.*, 21(4), 733–740.
- [11] Safari, A., Mekhilef, S. (2011). Simulation and hardware implementation of incremental conductance MPPT with direct control method using cuk converter. *IEEE Transactions on Industrial Electronics*, 58(4), 1154–1161.