



Volume 122

2024

p-ISSN: 0209-3324

e-ISSN: 2450-1549

DOI: <https://doi.org/10.20858/sjsutst.2024.122.7>

Journal homepage: <http://sjsutst.polsl.pl>



Article citation information:

Korban, D., Melnyk, O., Onishchenko, O., Kurdiuk, S., Shevchenko, V. Obniavko, T. Radar-based detection and recognition methodology of autonomous surface vehicles in challenging marine environment. *Scientific Journal of Silesian University of Technology. Series Transport*. 2024, **122**, 111-127. ISSN: 0209-3324.
DOI: <https://doi.org/10.20858/sjsutst.2024.122.7>.

Dmytro KORBAN¹, Oleksiy MELNYK², Oleg ONISHCHENKO³, Serhii KURDIUK⁴, Valerii SHEVCHENKO⁵, Tatyana OBNIIVKO⁶

RADAR-BASED DETECTION AND RECOGNITION METHODOLOGY OF AUTONOMOUS SURFACE VEHICLES IN CHALLENGING MARINE ENVIRONMENT

Summary. This paper presents a methodology that combines radar polarization selection and recognition techniques for navigating objects in atmospheric formations, with a special focus on unmanned surface vehicles (ASVs). The proposed technique utilizes the concept of an energy dissipation matrix to represent these objects as characteristic “shiny dots”. By strategically changing the polarization of the emitted and received electromagnetic waves, the resulting echo energy dissipation matrix is determined. This approach allows the formation of

¹ Department of Ship Handling, National University “Odessa Maritime Academy”, 8, Didrikhson Str., Odesa, 65052, Ukraine. Email: korbandomv@gmail.com. ORCID: <https://orcid.org/0000-0002-6798-2526>

² Department of Navigation and Maritime Safety, Odessa National Maritime University, 34, Mechnikov Str., Odesa, 65029, Ukraine. Email: m.onmu@ukr.net. ORCID: <https://orcid.org/0000-0001-9228-8459>

³ Department of Technical Fleet Operation, National University “Odessa Maritime Academy”, 8, Didrikhson Str., Odesa, 65052, Ukraine. Email: oleganaton@gmail.com. ORCID: <https://orcid.org/0000-0002-3766-3188>

⁴ Institute of Naval Forces, National University “Odessa Maritime Academy”, 8, Didrikhson Str., Odesa, 65052, Ukraine. Email: serega.vms@ukr.net. ORCID: <https://orcid.org/0000-0002-3165-4571>

⁵ Department of Technical ship operation of the Institute of Postgraduate Education, National University “Odessa Maritime Academy”, 8, Didrikhson Str., Odesa, 65052, Ukraine. Email: oleganaton@gmail.com. ORCID: <https://orcid.org/0000-0003-3229-1909>

⁶ Department of Logistics, Odessa Military Academy, 10, Fontans'ka Rd, 10, Odesa, 65009 Ukraine. Email: tetiana.ob@ukr.net. ORCID: <https://orcid.org/0000-0002-8769-3844>

an intensity-based repository of atmospheric formations, which gives SRPC a complete set of tools to account for atmospheric conditions in radar identification of remote objects, including ASVs. The practical application of this technique extends to the improvement of a distinct class of shipborne radar systems optimized for ASVs and their specific navigation requirements. Ultimately, this technology bridges the gap between advanced radar technology and the emerging field of unmanned ground vehicles, providing safer and more proficient navigation in challenging weather conditions.

Keywords: autonomous surface vehicles, object detection and ranging, radar technology, adverse weather conditions, atmospheric interference, environmental factors, signal characteristics, vessel particulars, sensor performance, adaptability, shipping, navigation, influence factors, detection accuracy

1. INTRODUCTION

Autonomous Surface Vehicles (ASVs) are unmanned or remote-controlled waterborne vehicles designed to operate on the surface of bodies of water without human intervention. These vehicles play a crucial role in various maritime applications, including environmental monitoring, oceanographic research, surveillance, security, and even maritime transportation. ASVs can vary in size and capabilities, ranging from small, compact units to larger vessels equipped with advanced sensors, communication systems, and navigation technologies and offer a compelling array of benefits for maritime operations. Their deployment enhances safety by tackling hazardous tasks without risking human lives, while also yielding cost efficiencies through reduced crew-related expenses. ASVs enable continuous and adaptable data collection, facilitating remote monitoring and research in otherwise inaccessible areas.

The literature review on the research topic included a comprehensive study of radar technologies and their application in maritime environments. Various aspects of radar systems [1], focuses on active phase-discharge antenna arrays. A monograph [2] covering various aspects of antenna systems. Methods and algorithms of information processing under interference conditions [3] considers multi-position radar systems. Authors in [4] discuss the impact of turbulence on radio wave polarization angle. The functionality and applications in challenging atmospheric and environmental conditions presents mathematical and statistical details related to radar modeling, particularly for stacked radar objects [5,6] are discussed. Topics such as antenna arrays and methods to enhance environmental monitoring along maritime routes using remote sensing explored in [7], the design, operation, and applications of radar systems on board ships [8]. The article [9] investigates the invisibility functions of two radiometric complexes and the technical aspects of radiometric systems, with a special focus on the analysis of invisibility. The article [10] explores the challenges and considerations when using radio technical systems of the Ukrainian Air Force in adverse weather conditions and during natural meteorological events.

The manual [11] dedicated to radar, AIS (Automatic Identification System), and target tracking for marine radar users. It covers radar principles, AIS, and techniques for tracking targets, making it a valuable resource for marine radar operators. The book [12] discusses the polarization of radio waves and the polarization structure of radar signals, and covers the theory and practical aspects of radio wave polarization in radar systems. The paper [13] explores radar recognition of navigation objects based on the polarization parameters of electromagnetic waves, mathematical and technical aspects of radar recognition of navigation objects from

polarization data are considered. In thesis [14] analysis of functional relationships between a navigation object and its environment, concerning the operation of a ship's radar station considered including the findings related to radar systems and their interactions with the ship's surroundings. Matrix of radar information channel propagation during radar observation of navigational objects researched in [15]. The paper [16] presents a lightweight radar ship detection framework with hybrid attentions and discusses the development of a ship detection system using radar data with a focus on attention mechanisms. In [17] introduced a novel approach for estimating ship speed and heading using radar sequential images, methodology and algorithms for ship speed and heading estimation based on radar data. The research [18] deals with inshore ship detection using multi-modality saliency analysis for synthetic aperture radar (SAR) images. The articles [19, 20] present a network for detecting small ships in synthetic aperture radar (SAR) imagery while considering sidelobes and focuses on ship detection in synthetic aperture radar (SAR) images using the YOLO-SARshipNet approach. In [21], methods for estimating ship parking parameters using Multi-LiDAR and MMV radar data fusion are discussed, in [22] beamforming using LOFAR radio telescopes for passive radar applications is investigated, and in [23] Cassegrain-type antennas used in radio telescopes, focusing on development and applications, making collective contributions to ship navigation, radio telescope technology, and antenna design knowledge studied. In [24,25] a multi-criteria approach focused on optimizing the composition of technical means is considered and a model for the structure of project portfolios is investigated. Paper [26] outlines the current state of the art of wired MSAs and describes their designs, types, benefits, and specific impacts in MSC systems, ships' electric propulsion systems operation on curvilinear trajectory studied in [27].

In today's maritime environment, characterized by an increasing number of ASVs, there is scientific uncertainty about the effectiveness and reliability of radar surveillance by shipboard radar systems. Such a problem arises due to the complex conditions of the marine environment, including atmospheric influences such as sea state, rain snow, hail, etc., which can distort radar signals and make it difficult to detect ASVs. Moreover, the variety of ASV configurations and sizes can cause variable radio signatures, making identification and tracking more difficult. Thus, there is a need for research and development of technical solutions to improve the reliability and accuracy of ASV surveillance by shipboard radars, considering the diverse atmospheric and marine environment effects as well as ASV characteristics.

This scientific challenge emphasizes the need for research and innovation to improve surveillance of autonomous surface vehicles using shipborne radar systems, and guides the development of new methods and technologies to overcome the challenges associated with detecting and monitoring ASVs in various maritime environments.

2. MATERIALS AND METHODS

The development of a technique that combines the methods of selection and recognition of radar polarization for surface objects in dense atmospheric formations with special emphasis on ASVs is an urgent task, so the proposed technique uses the concept of energy dissipation matrix to represent these objects in the form of characteristic "shining points". By strategically changing the polarization of emitted and received electromagnetic waves, the resulting echo-signal energy dissipation matrix is determined.

This research task focuses solely on radar systems (radar) for surveillance of ASVs which are driven by the desire to better understand and improve the detection, monitoring and tracking processes of ASVs in variable marine and atmospheric environments. The problem is focused

on analyzing and improving the radio signatures of ASVs and optimizing radar systems for their effective detection, while ASVs, while significant, and are focused on the transmission of vessel information, which is beyond the scope of this research problem. The representation of factors influencing detection of ASVs in challenging weather conditions (Tab.1):

Tab. 1

The factors influencing detection of surface objects
in challenging weather conditions

Factors	Weather conditions	Impact on radar performance
Atmospheric Conditions and Interference	Rain and Snow	Weaken radar signals, create additional reflections
	Fog and Mist	Scatter radio waves, reduce visibility
	Wind and Storm	Alter vessel trajectories, impact on detection accuracy
Environmental factors and dynamics of the marine environment	Sea Waves	High waves cause multiple reflections, hinder signal accuracy
	Sea Spray	Creates additional radar reflections, affects target separation
	Icing	Increases radar cross-section, alters vessel characteristics
Radar and Signal Characteristics	Frequency Choice	Different frequencies react differently to conditions
	Disorder and noise	Electromagnetic interference affects signal quality
	Sea Clutter	Reflections from sea surface and objects, obscures targets
Vessel Characteristics and Particulars	Hull shape	Complex shapes hinder accurate radar readings
	Hull Material	Different materials scatter radio waves differently
	Principal Dimensions and Motion Parameters	Impact target's radar cross-section
Sensor Performance and Adaptability	Adaptive Algorithms	Respond to changing conditions for accurate readings
	Noise Suppression	Techniques to mitigate electromagnetic interference
	Signal Processing	Extract valid signals from noise and interference

This schematic visually represents the various factors that can affect the detection of ASVs in challenging weather conditions. Each section highlights a specific factor and its influence on the effectiveness of radar-based detection for ASVs.

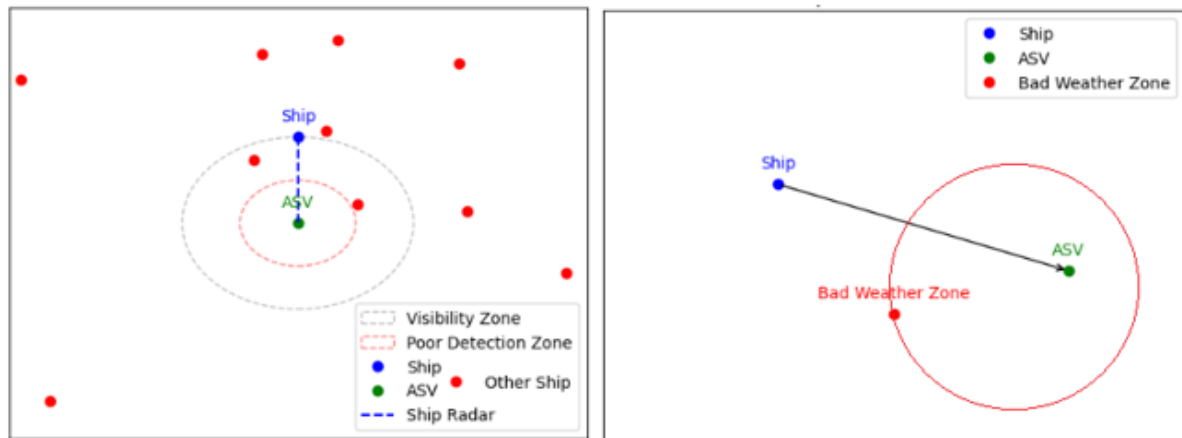

Fig.1. Ship radar station and detection zones

The histogram in Fig. 2 illustrates the influence of various factors on the detection of ASVs in complex maritime environments. The factors are categorized and listed along the vertical axis, while the horizontal axis represents the impact score on a scale of one to ten, where (1) represents minimal impact and (10) represents significant impact, and serves to visually display the varying degree of impact of each factor on ASV detection, providing insight into optimizing detection strategies in adverse marine environment:

- Atmospheric Conditions and Interference factor, ranked with a high influence rating of (8), highlights the impact of atmospheric phenomena and interference, such as rain, fog, and wind, on ASV detection accuracy.
- Environmental Factors and Marine Dynamics with a rating of (7) emphasizes the relevance of environmental conditions like sea state, water spray, and marine icing in affecting ASV detection.
- Radar and Signal Characteristics (9) factor holds substantial influence with a rating of 9, underscoring the role of radar system parameters and signal characteristics in determining ASV detectability.
- Vessel Particulars factor assigned a rating of (5) indicates the moderate impact of vessel-specific characteristics, including size, shape, and materials, on ASV detection performance.
- Sensor Performance and Adaptability factor with a rating of (6) underscores the influence of sensor performance and adaptability, including the ability to process signals and adjust to changing conditions, on ASV detection reliability.

The above scheme highlights key factors affecting the detection of ASV in challenging weather conditions. Atmospheric factors such as rain, fog, and strong winds can hinder visibility and signal strength. Environmental dynamics, including high waves and marine icing, may influence target detection and cause reflections. Radar characteristics such as frequency choice and clutter influence signal quality and background noise. Vessel traits like shape and material influence radar cross-section. Sensor adaptability and noise suppression techniques are essential for accurate ASV detection. These insights emphasize the need for comprehensive considerations when detecting ASVs in adverse marine environments.

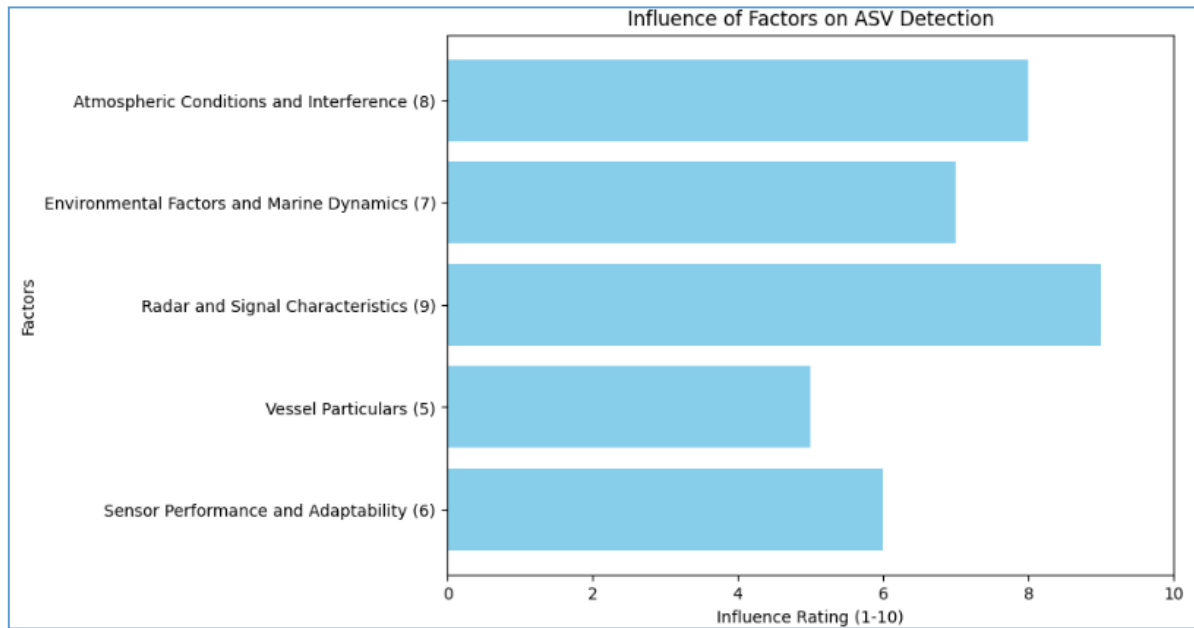

Fig.2. Influence of various factors on the detection of ASVs

Spatial and temporal filtering of interference can be performed by ship radar polarization complexes (SRPC) having different types of antennas, including phased antenna arrays. SRPC receiver simultaneously receives echo signals from navigational object and atmospheric formation (complex object). The echo signals of the atmospheric formation obscure the echo signals of the navigation object observed by the SRPC. Hydrometeor particles of the atmospheric formation are dipole reflectors for the emitting antenna SRPC of the centimeter wave length diapason (3-10 cm) and have a length equal to $\lambda/2$ with an average effective dipole scattering surface $\bar{\sigma}_{eff}$ equal to $0,17 \lambda^2$. When multiplied $\bar{\sigma}_{eff}$ by the number of dipole reflectors n in the radar volume of the atmospheric formation, the value of the total effective scattering surface of the atmospheric formation particles simultaneously scattering the energy of the irradiating wave is obtained:

$$\sigma_{\Sigma effAF} = 0,17 \lambda^2 n \quad (1)$$

The effectiveness of radar observation of a navigation object, located in the area of the atmospheric formation, will be if the total effective scattering surface of the particles of the atmospheric formation is less than the effective scattering surface of the navigation object by the value of the suppression coefficient N , i.e.

$$\sigma_{\Sigma effAF} \ll N \cdot \sigma_{effNO}, \quad (2)$$

where $N = \frac{\sigma_{effAF}}{\sigma_{effNO}}$ is the suppression coefficient of interfering background atmospheric formation.

However, real $\sigma_{\Sigma_{effAF}}$ and σ_{effNO} are difficult to obtain, so it is necessary to search for other directions to identify a radar observation object from the passive interference of atmospheric formation on the ship's route. Interference from hydrometeors creates images on the SRPC indicator identical to navigational objects, which obscures them and reduces radar observation.

Various interference suppression methods and devices have now been developed, including upper-pass and lower-pass filter systems, band-pass filters, angle selection and blanking devices, pulse repetition frequency discriminators, frequency hopping, side-lobe compensators, etc. However, uncertainties caused by interference lead to erroneous, relative to the real situation, decisions. The different situations available for radar observation of navigational objects make it necessary to take into account the semantics and pragmatics of the echo signals of the atmospheric interference. This necessitates the use of a thesaurus, which forms the information about the atmospheric interference (intensity of the precipitation). The characteristics of the echo signals during radar observation of a navigation object in atmospheric interference are based on temporal, spatial and polarization parameters. The polarization actual Stokes parameters allow the object recognition on the background of atmospheric interference using the thesaurus available in the SRPC archive by comparing the echo signals of the navigation object with the echo signals from precipitation of known intensity. The simulation model in this case is an energy scattering matrix with the elements represented by the actual Stokes energy parameters, which are easily measured by SRPC. The polarization direction of atmospheric interference compensation in radar observation of navigation objects is an alternative solution to the existing problem [13-15].

Obtaining and use of energy scattering matrix for suppression of atmospheric interference in radar observation of navigational objects is a current concern in shipborne radiolocation.

Remote measuring of time-averaged polarization parameters of Stokes echo signals S_1, S_2, S_3, S_4 of partially polarized wave during radar observation of navigation objects located in the zone of atmospheric formation was carried out in linear (L) and circular (CR) bases. When using linear basis, the relationship between Stokes parameters and amplitudes of orthogonal electromagnetic wave components $E_{x\max}, E_{y\max}$ and phase difference F_{xy} between them is established using the following relations:

$$\begin{aligned} S_1^L &= \langle E_{x\max}^2 \rangle + \langle E_{y\max}^2 \rangle, \\ S_2^L &= \langle E_{x\max}^2 \rangle - \langle E_{y\max}^2 \rangle, \\ S_3^L &= 2 \langle E_{x\max} \rangle \langle E_{y\max} \rangle \cos F_{xy}, \\ S_4^L &= 2 \langle E_{x\max} \rangle \langle E_{y\max} \rangle \sin F_{xy}. \end{aligned} \tag{3}$$

Using a circular basis, the relationship between Stokes parameters and the amplitudes of the orthogonal right $E_{R\max}$ and left $E_{L\max}$ rotation components of the electric wave vector and the phase difference between them F_{RL} is written in the form:

$$\begin{aligned} S_1^{CR} &= \langle E_{R\max}^2 \rangle + \langle E_{L\max}^2 \rangle, \\ S_2^{CR} &= \langle E_{R\max}^2 \rangle - \langle E_{L\max}^2 \rangle, \\ S_3^{CR} &= 2 \langle E_{R\max} \rangle \langle E_{L\max} \rangle \cos F_{RL}, \\ S_4^{CR} &= 2 \langle E_{R\max} \rangle \langle E_{L\max} \rangle \sin F_{RL}. \end{aligned} \tag{4}$$

The totality of Stokes parameters of electromagnetic wave echo signals of the observed SRPC navigation object at each considered moment of time reflects its functioning. The use of linear and circular bases is considered in terms of the value of the information obtained when observing a navigational object.

Let us introduce the Stokes vector parameter for the quasimonochromatic wave emitted by the SRPC antenna as grouped Stokes parameters in a 4x4 vector-column:

$$S = \begin{bmatrix} S_1 \\ S_2 \\ S_3 \\ S_4 \end{bmatrix}. \quad (5)$$

A navigation object observed by SRPC is sequentially irradiated by an electromagnetic wave of four polarizations, of which three are linear vertical (*LV*), linear horizontal (*LH*) and with the electric vector inclined at 45° (*L45°*) and one circular (*CR*) of right or left direction of rotation of the electric vector. The Stokes vector for each polarization of the emitted wave is written by the following relations:

$$\begin{aligned} S_{em}^{LV} &= S_{1em}, S_{2em}, 0, 0; \\ S_{em}^{LH} &= S_{1em}, -S_{2em}, 0, 0; \\ S_{em}^{L45^\circ} &= S_{1em}, 0, S_{3em}, 0; \\ S_{em}^{CR} &= S_{1em}, 0, 0, S_{4em}. \end{aligned} \quad (6)$$

When an irradiating wave of any of the four polarizations listed above is scattered on a navigation object, an atmospheric formation or a navigation object and an atmospheric formation (complex object), an echo signal of a certain polarization is formed, carrying information about their reflecting properties. The Stokes parameters of the irradiating wave undergo changes during reflection, since the reflected electromagnetic wave in both cases has a polarization structure different from the polarization of the irradiating wave. The reflection coefficients also change. Due to the linearity of the electromagnetic wave scattering process, the relationship between the polarization parameters of the reflected wave and the reflection coefficients for each of the given polarizations of the irradiated wave are generally determined by a relation consisting of three matrices, where the elements of the first and third matrices represent the Stokes parameters of the radiated and reflected waves, and the elements of the second matrix characterize the reflective properties of the complex object of radar surveillance SRNS:

$$\begin{bmatrix} S_{1ref}(t) \\ S_{2ref}(t) \\ S_{3ref}(t) \\ S_{4ref}(t) \end{bmatrix} = \begin{bmatrix} \alpha_{11}(t) & \alpha_{12}(t) & \alpha_{13}(t) & \alpha_{14}(t) \\ \alpha_{21}(t) & \alpha_{22}(t) & \alpha_{23}(t) & \alpha_{24}(t) \\ \alpha_{31}(t) & \alpha_{32}(t) & \alpha_{33}(t) & \alpha_{34}(t) \\ \alpha_{41}(t) & \alpha_{42}(t) & \alpha_{43}(t) & \alpha_{44}(t) \end{bmatrix} \cdot \begin{bmatrix} S_{1em}(t) \\ S_{2em}(t) \\ S_{3em}(t) \\ S_{4em}(t) \end{bmatrix}. \quad (7)$$

As a result of irradiation of a complex object with electromagnetic waves of four fixed polarizations, all elements $\alpha_{11} \dots \alpha_{44}$ of matrix (7), which are the actual Stokes energy parameters forming the energy scattering matrix of the complex object (CO) and fully characterizing its reflecting properties, i.e.

$$[S_{engCO}(t)] = \begin{bmatrix} \frac{S_{1ref}^{LV}(t) + S_{1ref}^{LH}(t)}{2} & \frac{S_{1ref}^{LV}(t) - S_{1ref}^{LH}(t)}{2} & S_{1ref}^{LA45^\circ}(t) - \frac{S_{1ref}^{LV}(t) + S_{1ref}^{LH}(t)}{2} & S_{1ref}^{CR}(t) - \frac{S_{1ref}^{LV}(t) + S_{1ref}^{LH}(t)}{2} \\ \frac{S_{2ref}^{LV}(t) + S_{2ref}^{LH}(t)}{2} & \frac{S_{2ref}^{LV}(t) - S_{2ref}^{LH}(t)}{2} & S_{2ref}^{LA45^\circ}(t) - \frac{S_{2ref}^{LV}(t) + S_{2ref}^{LH}(t)}{2} & S_{2ref}^{CR}(t) - \frac{S_{2ref}^{LV}(t) + S_{2ref}^{LH}(t)}{2} \\ \frac{S_{3ref}^{LV}(t) + S_{3ref}^{LH}(t)}{2} & \frac{S_{3ref}^{LV}(t) - S_{3ref}^{LH}(t)}{2} & S_{3ref}^{LA45^\circ}(t) - \frac{S_{3ref}^{LV}(t) + S_{3ref}^{LH}(t)}{2} & S_{3ref}^{CR}(t) - \frac{S_{3ref}^{LV}(t) + S_{3ref}^{LH}(t)}{2} \\ \frac{S_{4ref}^{LV}(t) + S_{4ref}^{LH}(t)}{2} & \frac{S_{4ref}^{LV}(t) - S_{4ref}^{LH}(t)}{2} & S_{4ref}^{LA45^\circ}(t) - \frac{S_{4ref}^{LV}(t) + S_{4ref}^{LH}(t)}{2} & S_{4ref}^{CR}(t) - \frac{S_{4ref}^{LV}(t) + S_{4ref}^{LH}(t)}{2} \end{bmatrix} \quad (8)$$

All elements included in the energy dissipation matrix (8) of a complex object are easily measured by SRPC on the ship's route. The energy dissipation matrix solves the problem of polarization selection of the navigation object located in the zone of dangerous atmospheric formation. Separation of echo-signals of a navigation object and an atmospheric formation is performed by the difference of their energy scattering matrices by subtracting from the energy matrix of a complex object the energy matrix of an atmospheric formation, which for known types of dangerous atmospheric formations (precipitation of different intensity) is located in the computer archive of SRNS. Most real atmospheric media have electrodynamic parameters corresponding to the real and symmetric energy dissipation matrix. Stokes parameters are measured in one-dimensional radar channels in the absence of physical and geometric boundaries of the radar volume of the atmospheric formation. Stokes parameters are measured in one-dimensional radar channels in the absence of physical and geometric boundaries of the radar volume of the atmospheric formation. According to the selected irradiated and reflected signals from the navigation object and atmospheric formation, the structure of the energy matrix of scattering of the complex object is determined, which makes it possible to relate the Stokes parameters of the complex object with radar signals and, ultimately, to ensure the operation of SRNS in a complex atmospheric environment when solving the problem of polarization selection.

3. RESULTS AND DISCUSSION

The energy matrix of the atmospheric formation is related to the concept of thesaurus, i.e., the accumulated information about the structure of the atmospheric formation and the processes occurring in it. Radar cumulative processing of measured actual Stokes parameters of echo-signals of partially polarized waves of a complex object allows us to apply its energy matrix of scattering to separate the echo-signal of a navigation object from the echo-signal of a complex object.

In order to solve the problem, the echo signal of the navigation object is separated from the echo signal of the complex object by using two energy matrices $[S_{engCO}]$ and $[S_{engAF}]$. The energy matrix of the atmospheric formation $[S_{engAF}]$ is known in advance taking into account its $z - I$ ratio presented in (Table 2) for certain precipitation intensities falling in a certain region on the ship's route according to meteorological radar stations.

The SRPC measures the atmospheric formation Stokes parameters for the precipitation intensities that may be encountered on the ship's route, including the precipitation intensities presented in Table 2. From the radar measurements of the SRPC Stokes parameters, energy scattering matrices of precipitation are compiled for each intensity. Using the measured first Stokes parameter the echo signal of the complex object, the intensity of the precipitation on the ship's route is determined, which is entered into the search program atmospheric formation energy matrix of the measured intensity.

Tab. 2.
Radar reflectivity of precipitation (z) as a function of intensity of precipitation (I)

I , mm/h	z , dB							
	1	2	3	4	5	6	7	8
1	23,0	24,4	23,1	23,6	-	22,6	-	-
5	34,2	34,2	35,0	34,1	34,7	35,4	35,1	-
10	39,0	38,4	40,1	38,6	38,9	41,3	40,7	33,4
15	41,1	42,1	43,0	40,1	40,1	45,2	42,4	36,1
25	45,0	45,2	46,0	45,0	45,2	49,1	47,3	39,2
50	50,2	48,3	52,0	49,1	48,7	54,4	53,9	44,6
100	55,0	52,4	57,1	53,6	52,9	60,0	59,5	49,4
150	57,9	54,8	60,2	56,3	55,4	63,4	62,9	52,2

The devices (Fig. 3 and Fig. 4) automatically subtract from the energy matrix of the echo-signal of the complex object the energy matrix of the atmospheric formation by precipitation of the measured intensity at the moment of radar observation of the complex object. The energy matrix of the navigational object obtained as a result of subtraction is fed to the SRNS indicator and computer display for remote observation of the navigational object located in the zone of dangerous atmospheric formation on the ship's route.

Stokes parameters of the CO echo signal when it is irradiated by electromagnetic waves of four polarizations:

$$\begin{aligned}
 & S_1^1, S_1^2, S_1^3, S_1^4 (S_{1ref}^{LV}, S_{1ref}^{LH}, S_{1ref}^{L45^\circ}, S_{1ref}^{CR}) - \text{the first parameter;} \\
 & S_2^1, S_2^2, S_2^3, S_2^4 (S_{2ref}^{LV}, S_{2ref}^{LH}, S_{2ref}^{L45^\circ}, S_{2ref}^{CR}) - \text{second parameter;} \\
 & S_3^1, S_3^2, S_3^3, S_3^4 (S_{3ref}^{LV}, S_{3ref}^{LH}, S_{3ref}^{L45^\circ}, S_{3ref}^{CR}) - \text{third parameter;} \\
 & S_4^1, S_4^2, S_4^3, S_4^4 (S_{4ref}^{LV}, S_{4ref}^{LH}, S_{4ref}^{L45^\circ}, S_{4ref}^{CR}) - \text{fourth parameter.}
 \end{aligned} \tag{9}$$

So, for liquid precipitation of intensity $I = 25 \text{ mm/h}$ their energy scattering matrix of the echo signal partially polarized wave has the following values of its elements (Stokes parameters):

$$\left[S_{engAF} \right] = \begin{bmatrix} 12,75 & 12,25 & 0,25 & 0,25 \\ 12,75 & 12,25 & -0,75 & -0,75 \\ 0 & 0 & 3,50 & 0,40 \\ 0 & 0 & 0,40 & 3,50 \end{bmatrix} \tag{10}$$

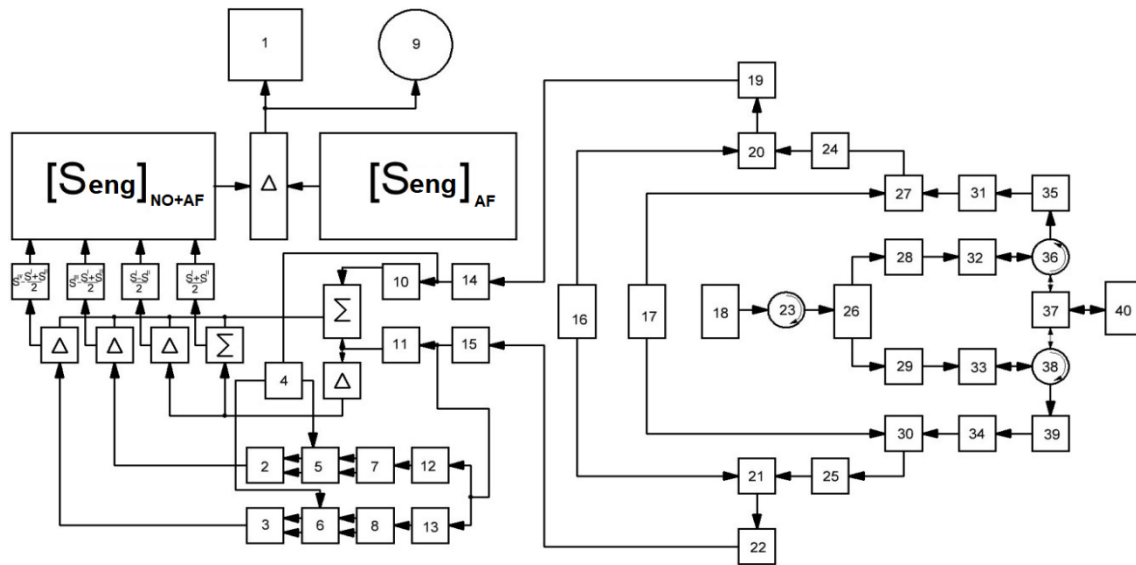

Fig. 3. Functional scheme of SRPC device synthesizing algorithm for solving the polarization selection problem of navigation object located in the zone of dangerous atmospheric formation: $[S_{engCO}]$ - the energy scattering matrix of the complex object; $[S_{engAF}]$ - the energy scattering matrix of the atmospheric formation; Δ - subtractors; Σ - summatoms

Where: 1 - SRPC computer display; 2,3 - DC amplifiers; 4,12,13 - phase-shifter amplifiers; 5,6 - multiplication stages; 7,8 - paraphase amplifiers; 9 - SRPC display; 10,11 - quadrature detectors; 14,15,19,22 - line amplifiers for 4 MHz intermediate frequency; 16,17 - heterodynes for 4 MHz and 30 MHz intermediate frequency; 18 - SRPC transmitter; 20,21 - balance mixers for 4 MHz intermediate frequency; 23 - circulator; 24,25 - 30MHz intermediate frequency amplifiers; 26 - power divider; 27,30 - 30MHz intermediate frequency balanced mixers; 28,29 - phase shifters; 31,34 - high frequency signal amplifiers; 32,33 - attenuators; 35,39 - receiver protection arresters; 36,38 - antenna switches; 37 - polarization selector; 40 - transmitter

The energy scattering matrix of the complex object echo signal has the following value of elements:

$$[S_{engCO}] = \begin{bmatrix} 15,40 & 14,50 & 0,45 & 0,45 \\ 15,40 & 14,50 & -0,45 & -0,45 \\ 0 & 0 & 4,20 & 0,70 \\ 0 & 0 & 0,70 & 4,20 \end{bmatrix} \quad (11)$$

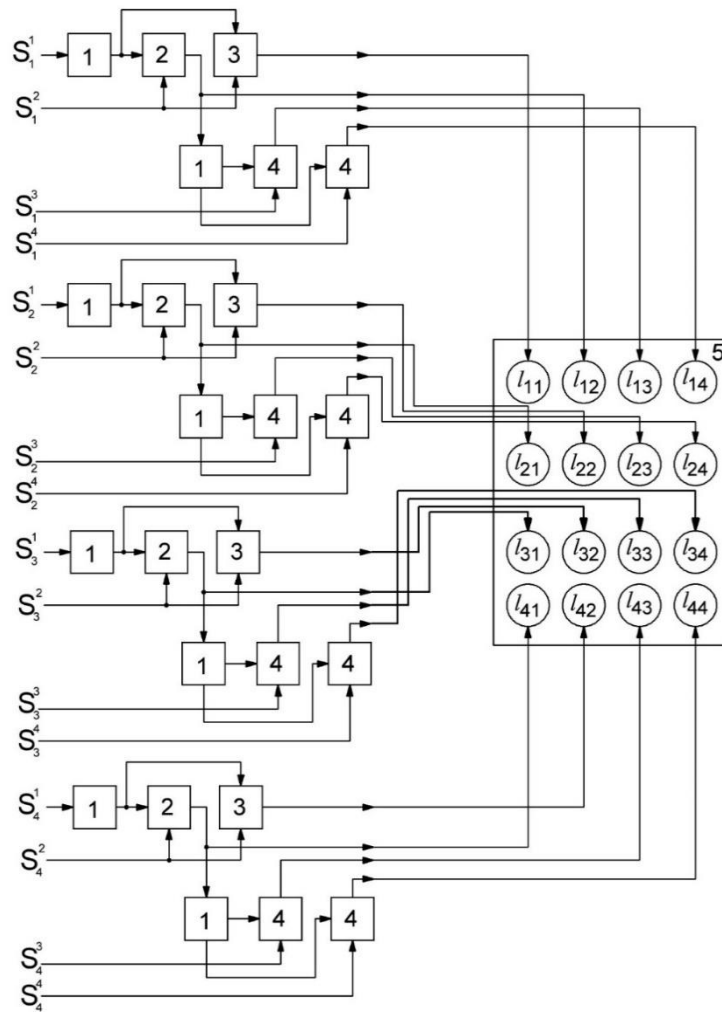

Fig. 4. Functional scheme of the device for obtaining the energy scattering matrix of the complex object echo signal (CO) l_{11} - l_{44} - the elements of the CO energy scattering matrix; 1 - RLT - D6386 ultrasonic delay lines; 2, 3, 4 - summing and subtraction blocks; 5 - energy scattering matrix of the complex object echo signal

Then the energy scattering matrix of the navigational object echo signal determined as the difference and written in the form:

$$[S_{engNO}] = [S_{engCO}] - [S_{engAF}] = \begin{bmatrix} 2,65 & 2,25 & 0,20 & 0,20 \\ 2,65 & 2,25 & -0,30 & -0,30 \\ 0 & 0 & 0,70 & 0,30 \\ 0 & 0 & 0,30 & 0,70 \end{bmatrix} \quad (12)$$

When the intensity of liquid precipitation $I = 10 \text{ mm/h}$, the energy scattering matrix of the atmospheric formation has the following values of its elements:

$$\left[S_{engAF} \right] = \begin{bmatrix} 1,18 & 0,35 & 0 & 0,01 \\ 0,35 & 1,18 & -0,84 & -0,01 \\ 0 & 0 & 1,12 & 0,04 \\ 0 & 0 & -0,04 & 1,12 \end{bmatrix} \quad (13)$$

The energy scattering matrix of the echo signals of the complex object $\left[S_{engCO} \right]$ has the following values of its elements:

$$\left[S_{engCO} \right] = \begin{bmatrix} 3,05 & 2,10 & 0,85 & 0,85 \\ 3,05 & 2,10 & -0,75 & -0,75 \\ 0 & 0 & 1,90 & 0,08 \\ 0 & 0 & -0,08 & 1,90 \end{bmatrix} \quad (14)$$

The energy scattering matrix of the echo signals of the navigation object $\left[S_{engNO} \right]$ observed by SRPC is written in the form:

$$\left[S_{engNO} \right] = \left[S_{engCO} \right] - \left[S_{engAF} \right] = \begin{bmatrix} 1,87 & 1,65 & 0,85 & 0,84 \\ 2,70 & 0,92 & 1,69 & -0,76 \\ 0 & 0 & 1,78 & 0,04 \\ 0 & 0 & -0,12 & 0,78 \end{bmatrix} \quad (15)$$

At air temperatures of less than $-2^{\circ}C$, snowfall intensity is determined by three gradations: weak ($I = 0,02 - 0,10 \text{ mm/h}$), moderate ($I = 0,11 - 1,00 \text{ mm/h}$) and strong ($I > 1,00 \text{ mm/h}$). The energy scattering matrix of the snowfall echo signals $\left[S_{engAF} \right]$ of strong intensity is the written in the form:

$$\left[S_{engAF} \right] = \begin{bmatrix} 1,48 & 0,75 & 0,1 & 0,01 \\ 1,48 & 0,75 & -0,73 & -0,73 \\ 0 & 0 & 1,26 & 0,22 \\ 0 & 0 & -0,04 & 1,12 \end{bmatrix} \quad (16)$$

The energy scattering matrix of the echo signals of the complex object $\left[S_{engCO} \right]$ observed by the SRPC is the written in the form:

$$\left[S_{engCO} \right] = \begin{bmatrix} 1,83 & 1,01 & -0,02 & -0,02 \\ 1,83 & 1,01 & 0,85 & 0,85 \\ 0 & 0 & 1,83 & 0,53 \\ 0 & 0 & 0,53 & 1,83 \end{bmatrix} \quad (17)$$

The energy scattering matrix of the echo signals of the navigation object $[S_{engNO}]$ located in the zone of falling snow with intensity more than 1mm/h , observed by SRPC, is written in the form:

$$[S_{engNO}] = \begin{bmatrix} 0,35 & 0,26 & -0,01 & -0,01 \\ 0,35 & 0,26 & 1,58 & 1,58 \\ 0 & 0 & 0,57 & 0,31 \\ 0 & 0 & 0,57 & 0,71 \end{bmatrix} \quad (18)$$

The obtained matrix of energy dissipation of echo-signals of a navigation object corresponds to its representation in the form of a set of “shining points”, to a certain choice of polarizations of the electromagnetic wave irradiating the navigation object, and to the received echo-signals of vertical and horizontal polarizations.

The advantage of the considered method of radar polarization selection for a navigation object located in the zone of a dangerous atmospheric formation is the accumulation of meteorological information on reflective properties of existing dangerous atmospheric formations, which is entered into the SRNS data bank. The task of SRPC is to measure actual parameters of Stokes echo-signals from a complex object on the ship's route, by which the intensity of the process in the atmospheric formation (intensity of rain or snowfall) is determined and on the basis of the available thesaurus the measured intensity of a dangerous atmospheric formation is compared with the existing ones in the SRPC data bank. For the measured intensity in the SRPC data bank, the energy dissipation matrix of the observed hazardous atmospheric formation is automatically found. From the energy dissipation matrix of the complex object obtained by the SRPC shaper (Fig. 3 and Fig. 4), the energy dissipation matrix of the hazardous atmospheric formation is subtracted. When subtracting from the atmospheric formation energy dissipation matrix the complex object energy dissipation matrix, the navigation object energy dissipation matrix is obtained, which is fed to the display and indicator of the SRPC computer for its remote radar observation. Taking into account the separation of the echo-signal of the atmospheric formation and the echo-signal of the complex object by their energy dissipation matrices and obtaining the energy dissipation matrix of the navigation object, the formed thesaurus of atmospheric formations of certain intensities allows SRPC to effectively use the accumulated information about the atmospheric formation and to fully consider the factors of the atmospheric environment during radar recognition of remote objects of observation.

The results obtained, which are methodological in nature, can be further embodied in the task of unifying the procedures for improving a ship radar complex of a certain type and its functional capabilities, and the practical usefulness of the considered methodology for recognizing navigational objects located in the zone of dangerous atmospheric formation is aimed at the application of program-target methodology of detection, selection, and recognition of navigational objects.

When implementing the algorithm of radar detection and polarization selection of navigation objects, the main element of the SRNS structure is a radar antenna, which implements the algorithm of radar detection and polarization selection of a navigation object according to its energy dissipation matrix. In solving this problem, an omnipolarized antenna, which is a polarization analyzer, is used to control the amplitude, phase, and polarization of the radiated electromagnetic wave.

The practical application of this technique extends to the improvement of a distinct class of ship radar systems optimized for ASV detection and their special navigational requirements. The deployment of the radar detection and polarization selection algorithm for navigational objects takes place around the SRPC radar antenna, which plays a central role in the implementation of the radar detection and polarization selection algorithm using an energy dissipation matrix. In addition, the integration of an omnipolarized antenna acting as a polarization analyzer allows precise control of the basic properties of electromagnetic waves, including amplitude, phase, and polarization.

4. CONCLUSION

This study emphasizes the importance of using the energy scattering matrix of complex objects to solve the difficult problem of polarization selection of navigation objects in complex atmospheric conditions on seaways. The effective use of real Stokes polarization parameters embedded in the energy scattering matrix of complex objects observed with SRPC provides a robust methodology. This methodology allows efficient separation of echo signals from navigational objects and complex entities, even under varying degrees of atmospheric interference. Characteristically, this innovation is equally applicable to autonomous surface vehicles, extending further to underwater vehicles. Due to the effective separation of radar echo signals from ASVs and their environment, including complex atmospheric interference, the technique can improve the accuracy and efficiency of radar-guided navigation for both surface and underwater autonomous vehicles. The research not only proposes the solution for radar echo separation, but also demonstrates its ability to improve radar navigation performance under various atmospheric phenomena. This is a notable step towards enhancing navigational safety and situational awareness on maritime routes, covering both surface and underwater environments.

References

1. Voskresensky D.I. 2004. *Active phase-discharge antenna arrays*. Radiotekhnika. 488 p.
2. Galimov G.K. 2013. *Antennas of radio telescopes, space communication and radiolocation systems*. Monograph. NPK "Antenny-Svyaz". 391 p.
3. Zaitsev D.V. 2004. *Multiposition radar systems. Methods and algorithms of the information processing in the interference conditions*. Radiotekhnika. 488 p.
4. Averyanova Yu., A. Averyanov, F. Yanovsky. 2010. "Statistical evaluation of the turbulence influence on the change of the polarization angle of the radio waves reflected from the hydro-theater". *Electronics and Systems Research* 2(24): 5-11.
5. Plekin, V.Ya. 2003. *Digital researches of moving circuits selection*. SEINS-PRESS. 80 p.
6. Kozlov I. 2000. "Parameters of a two-point statistical model for simulation of a complex radar object". *Radioelektronika* 5-6: 19-23.
7. Korban D. 2014. "Increasing the level of control over the ecological state of atmospheric air on the southern coast by remote monitoring methods". *Candidate of Technical Sciences (PhD) thesis*. Odesa National Marine Academy. 211 p.
8. Afanasyev V., A. Marinich, A. Pripotnyuk. 2010. *Ustinov Yu. Ship radar systems*. Edited by Yu. Ustinov. Velenara. 336 p.

9. Tymoshchuk O., Y. Shapran, I. Trofymenko. 2017. "Uncertainty function of dual radiometric complexes. Standardization, certification, quality assurance". *UkrNDNC* 2(105): 79-84.
10. Petrushenko M. 2009. "Peculiarities of the use of radio systems of the Armed Forces of Ukraine in unstable hydrometeorological and meteorological conditions". *Systems of administrative navigation and management* 2(10): 54-57.
11. Bole A.G., D.A. Wall, A. Norris. 2014. *Radar and ARPA Manual: Radar, AIS and Target Tracking for Marine Radar Users*. 3rd edition. Oxford, United Kingdom. Elsevier Science & Technology. 552 p.
12. Kozlov A., I. Kozlov, I. Logvin, V. Sarychev. 2005. *Polarization of radio waves. Polarization structure of radar signals*. Radiotekhnika. 704 p.
13. Putyatin V., S. Gudenko, S. Zaichko, D. Korban, A. Knyaz'. 2017. "Radar propagation of navigational objects on the way to the ship by the polarization parameter of the electromagnetic wave". *Mathematical Modeling and Systems* 4: 120-128.
14. Korban D.V. 2021. "Analysis of functional characteristics of navigation object and external environment at functional ship radar". *Ship Power Plants* 43: 172-195.
15. Putyatin V., D. Korban, A. Knyaz. 2018. "Radar information channel matrix for radar navigation objects positioning on the mainstem". *Mathematical Machines and Systems* 2: 141-147.
16. Nanjing Yu., R. Haohao, D. Tianmin, F. Xiaobiao. 2023. "A Lightweight Radar Ship Detection Framework with Hybrid Attentions". *Remote Sensing* 15: 2743. DOI: 10.3390/rs15112743.
17. Xueqian Xu, Wu Bing, Xie Lei, A.P. Teixeira, Yan Xinping. 2023. "A Novel Ship Speed and Heading Estimation Approach Using Radar Sequential Images". *IEEE Transactions on Intelligent Transportation Systems*: 1-14. DOI: 10.1109/TITS.2023.3281547.
18. Zhe Chen, Ding Zhiquan, Zhang Xiaoling, Wang Xiaoting, Zhou Yuanyuan. 2023. "Inshore Ship Detection Based on Multi-Modality Saliency for Synthetic Aperture Radar Images". *Remote Sensing* 15: 3868. DOI: 10.3390/rs15153868.
19. Yongsheng Zhou, Liu Hanchao, Ma Fei, Pan Zongxu, Zhang Fan. 2023. "A Sidelobe-Aware Small Ship Detection Network for Synthetic Aperture Radar Imagery". *IEEE Transactions on Geoscience and Remote Sensing* 1-1. DOI: 10.1109/TGRS.2023.3264231.
20. Bing Chen, Zhu Yuting, Wang Chen, Wang Xiaoqing. 2023. "Synthetic Aperture Radar Image Ship Detection Based on YOLO-SARshipNet". In: *Communications, Signal Processing, and Systems*. DOI: 10.1007/978-981-99-1260-5_1.
21. Zhuolin Wang, Zhang Yingjun. 2022. "Estimation of ship berthing parameters based on Multi-LiDAR and MMW radar data fusion". *Ocean Engineering* 266: 113155. DOI: 10.1016/j.oceaneng.2022.113155.
22. Droszcz A., K. Jedrzejewski, J. Kłos, K. Kulpa, M. Pozoga. 2021. "Beamforming of LOFAR Radio-Telescope for Passive Radiolocation Purposes". *Remote Sensing* 13: 810. DOI: 10.3390/rs13040810.
23. Sobirin Farhan Fatwa, Nugraha Satia, Haz Fauzia, Sitompul Peberlin. 2022. "Study of Cassegrain-type antenna for radio telescope". *Journal of Physics: Conference Series* 2214: 012028. DOI: 10.1088/1742-6596/2214/1/012028.
24. Rudenko S., A. Shakhov, I. Lapkina, O. Shumylo, M. Malaksiano, I. Horchynskyi. 2022. "Multicriteria Approach to Determining the Optimal Composition of Technical Means in the Design of Sea Grain Terminals". *Transactions on Maritime Science* 11(1): 28-44. DOI: 10.7225/toms.v11.n01.003.

25. Bushuyev S., S. Onyshchenko, N. Bushuyeva, A. Bondar. 2021. "Modelling projects portfolio structure dynamics of the organization development with a resistance of information entropy". *International Scientific and Technical Conference on Computer Sciences and Information Technologies 2*: 293-298. DOI: 10.1109/CSIT52700.2021.9648713.
26. Ilcev Dimov Stojce. 2023. "Design and Types of Wire Mobile Satellite Antennas (MSA)". *Journal of Maritime Research* 20(2):1-5.
27. Yarovenko V.A., P.S. Chernikov, E.I. Zaritskaya, A.N. Schumylo. 2020. "Control of electric ships' propulsion motors when moving on curvilinear trajectory". *Electrical Engineering and Electromechanics* 5: 58-65. DOI: 10.20998/2074-272X.2020.5.09.

Received 16.12.2023; accepted in revised form 02.02.2024



Scientific Journal of Silesian University of Technology. Series Transport is licensed under a Creative Commons Attribution 4.0 International License