

## ANALYSIS OF LDV OPERATION MANNER IN TERMS OF ITS ENVIRONMENTAL AND ECONOMICAL INDEXES

**Mateusz Nowak, Pawel Fuc**

*Poznan University of Technology  
Institute of Combustion Engines and Transport  
Piotrowo Street 3, 60-965 Poznan, Poland  
tel.: +48 61 665 2252, +48 61 665 2045, fax: +48 61 665 2204  
e-mail: mateusz.s.nowak@put.poznan.pl, pawel.fuc@put.poznan.pl*

**Maciej Andrzejewski**

*Rail Vehicles Institute "TABOR"  
Warszawska Street 181, 61-055 Poznan, Poland  
tel.: +48 61 653 4001, fax: +48 61 653 4002  
e-mail: m.andrzejewski@tabor.com.pl*

**Lukasz Rymaniak**

*Poznan University of Technology  
Institute of Combustion Engines and Transport  
Piotrowo Street 3, 60-965 Poznan, Poland  
tel.: +48 61 665 2118, fax: +48 61 665 2243  
e-mail: lukasz.rymaniak@put.poznan.pl*

### **Abstract**

*Environmental protection is becoming an increasingly important issue in every area of life. In recent times, a great emphasis has been placed on reducing the negative impact of automotive on human health at every stage of the vehicle's life. The most common impact of cars on the environment is the emission of pollutants from the exhaust system, created during the combustion of fuels in internal combustion engines. For this purpose, legislators introduce emission standards that must be met at the stage of vehicle approval for a given market. To meet these requirements, vehicle manufacturers modify the design of the drive units, body, and chassis to reduce weight and improve aerodynamic properties. This approach is methodologically correct because it is possible to compare the results obtained for different vehicles, but in real operation the level of harmful exhaust compounds, emissions and fuel consumption depend very much on the way the vehicle is used. As a manner of operation one can understand a variable load in the form of passengers or cargo, driving style, share of urban, extra-urban and motorway driving, terrain formation, ambient temperature and others. This article addresses issues related to the assessment of the impact of the light commercial vehicle operation manner on fuel consumption and the emission of harmful exhaust compounds. The problem was analysed in terms of the difference in vehicle load and driving style. Exhaust emission measurements were carried out using PEMS (Portable Emission Measurement System) analysers, which are state of the art devices for measuring exhaust emission in real operating conditions, called RDE (Real Driving Emissions).*

**Keywords:** *exhaust emission, road transport, RDE, PEMS, ecodriving*

### **1. Introduction**

Transport in 2015 was responsible for 24.7% of CO<sub>2</sub> emissions from fossil fuel combustion in the world [1]. The share of road transport in this emission is 72.6%, which confirms the importance of issues conducted to reduce the negative impact of vehicles on the environment [1]. This case is solved by many institutions, because the policy makers are in touch with

representatives from automotive industry and measuring equipment manufacturers. The policy regulations influence on exhaust gas emission limits and homologation methodology for new vehicles. Car manufacturers meet the emission requirements developing the combustion process, using more sophisticated engine exhaust aftertreatment systems and changing the chassis or bodywork properties. The homologation methodology evaluates to make the engine operation parameters as similar as possible to parameters during real vehicles operation. The most recent methodology for exhaust measurements is called RDE (Real Driving Emissions) and takes place on road under actual traffic conditions [2-5]. However, these issues are related for new vehicles under operation, which is assumed in the homologation test.

For vehicles operating on the road, another important issue in case of fuel consumption and exhaust emission is the operation manner of each vehicle. This issue is very complex, because it consists of many factors, such as vehicles maintenance differences in vehicle load and driving style. Actual the most popular among these three aspects is ecodriving, which contributes to influence of driving style on fuel consumption and exhaust emission from different categories of vehicles [6-9]. In the case of vehicle load, it is well known that more load will cause in higher fuel consumption and exhaust emission, but it is not easy to assume the values. The authors in this article analysed the influence of vehicle load and accelerating style on fuel consumption and exhaust emission. These measurements occurred in real driving conditions, using the mobile analyser for measuring exhaust emission of gaseous compounds during the operation of vehicle.

## 2. Test methodology

The tests were performed in real driving conditions on public roads in and around Poznan. All of the measurements occurred in the summertime and the temperature warried between 22-26°C. The test routes for assessing the influence of vehicle load on exhaust emission and fuel consumption were selected to reflect specific conditions of urban, extra urban and mixed driving style (Fig. 1). Another advantage of that methodology is the possibility to obtain results for different conditions, which could be helpful in drawing conclusions. Each test route had respectively about 5.3, 4.3 and 5.8 km length (Fig. 2). Differences in distance between tests with and without additional load were not greater than 2%. The measurements occurred in the afternoon and also covered the peak road traffic density. All of the tests were driven by the same driver to minimise the differences, although the real traffic conditions could disturb the driving behaviour. The duration of the repeated test phases differ up to 16 seconds, what is less than 5% (Fig. 3). The average speed, which results from travelled distance and test duration differ less than 4% (Fig. 4). The biggest differences were observed during mixed test cycle and it could be a result of local traffic conditions.

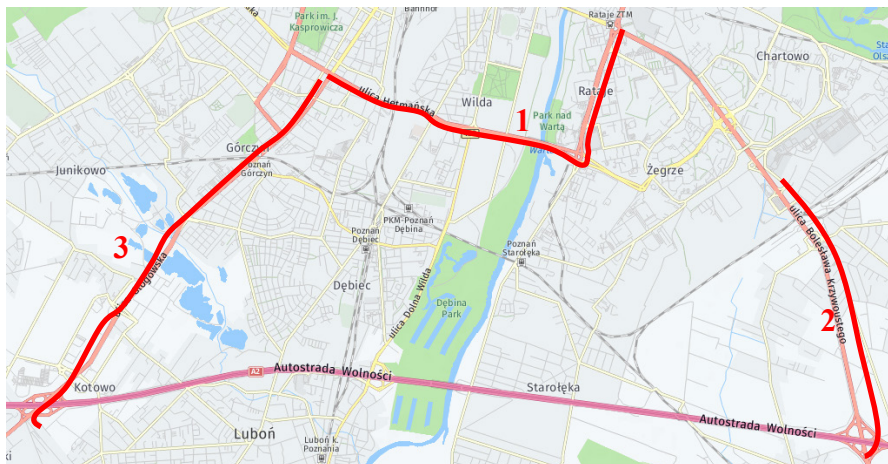

Fig. 1. Selected test routes; 1 – urban, 2 – extra urban, 3 – combined [10]

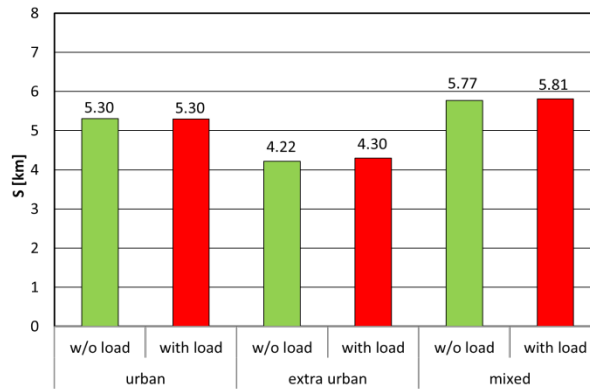

Fig. 2. Distance of analysed test cycles with and without load

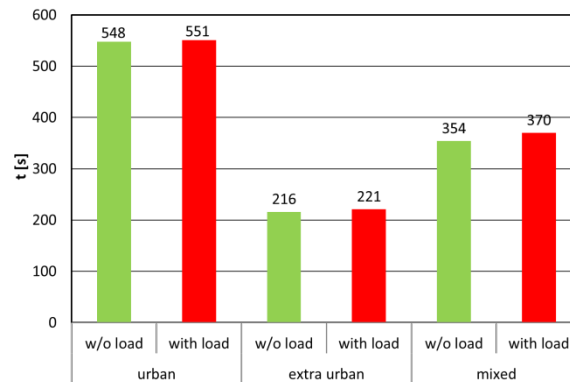

Fig. 3. Duration of analysed test cycles with and without load

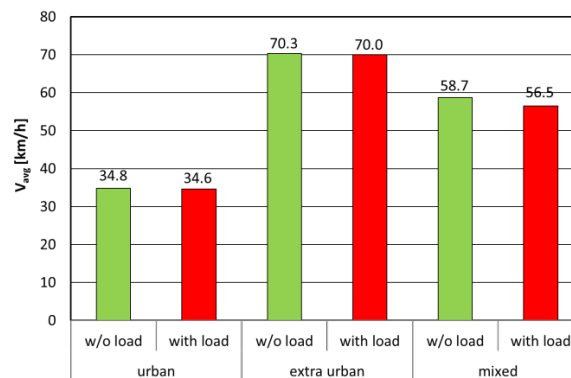

Fig. 4. Vehicles average speed during analysed test cycles with and without load

The tests reflecting different driving style took place on a straight road within a public parking area. This issue concerned on different behaviour in decreasing the vehicle speed. One methodology of slowing down uses engine operation at idling parameters and the second one used braking with the engine. Those tests could represent slowing down before traffic lights, crossroads, or level crossing, replacing vehicles coasting with idling engine. That behaviour is particularly emphasized by the promoters of eco-driving. The issue of avoiding unproductive engine idling; from point of view of the engine, efficiency is very favourable.

The test object was a LDV vehicle, which is very popular for different tasks and thus operates on urban and extra urban roads (Fig 5). The vehicle was propelled by CI engine and fulfilled the Euro 5 emission standard. The load tests were performer two times. Firstly, the measurements were conducted with measuring equipment, test crew and additional load. The second measurement was performed without additional load. The mass of test crew with equipment was about 350 kg and the additional load was about 400 kg.



Fig. 5. Test vehicle equipped with measuring devices and additional load

Exhaust gas measurements were performed using the state of the art PEMS measuring device SEMTECH-DS, which enables real driving emissions testing (Fig. 6). This device measures concentrations of gaseous toxic compounds. To obtain emission values related to travelled distance, data from exhaust flow meter and on-board diagnostics system were recorded. The analysers used in the SEMTECH-DS device operate on the basis of well-known methods and allowed during homologation tests [11].

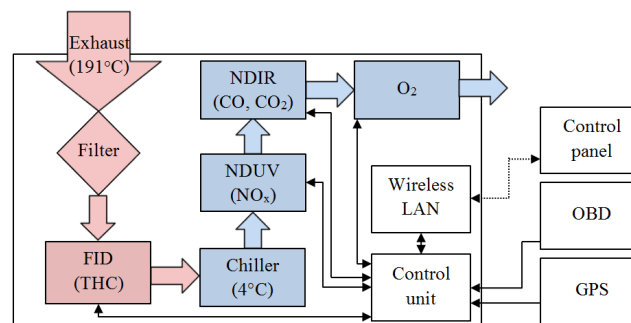

Fig. 6. Scheme of PEMS device SEMTECH-DS, used during tests [11]

### 3. Analysis of test results

On the basis of data from emission measurement device and on board diagnostics system, the road emission of exhaust gases was obtained (Fig. 7-10). Each of the graphs represents all of analysed compounds ( $\text{CO}_2$ ,  $\text{CO}$ ,  $\text{NO}_x$  and  $\text{HC}$ ) which reach different values and to make the graphs readable, the y-axis has logarithmic scale. Analysing the influence of vehicle load on exhaust emission, it could be assumed that in all of analysed test conditions, the  $\text{CO}_2$  emission is higher during test with additional load. The increase of  $\text{CO}_2$  emission in analysed urban cycle is about 6% and in extra urban cycle, the increase was about 15%. The greatest increase in  $\text{CO}_2$  emission was observed in the mixed cycle. The differences in  $\text{CO}_2$  emission could be assumed as differences in fuel consumption.  $\text{CO}$  emission during test with additional load is slightly lower in urban and mixed cycle (Fig 7, 9). In all of analysed measurements,  $\text{NO}_x$  emission is lower in test with additional load, and reverses dependence is observed in case of  $\text{HC}$  emission, where maximum increase in  $\text{HC}$  emission reaches 65%. These relations are unusual, because higher engine load causes higher temperatures which results in higher  $\text{NO}_x$  emission. However, modern engines are very sophisticated and it could be related with different mode of fuel injection system (injection pressure, injection timing, etc.) or engine aftertreatment systems operation.

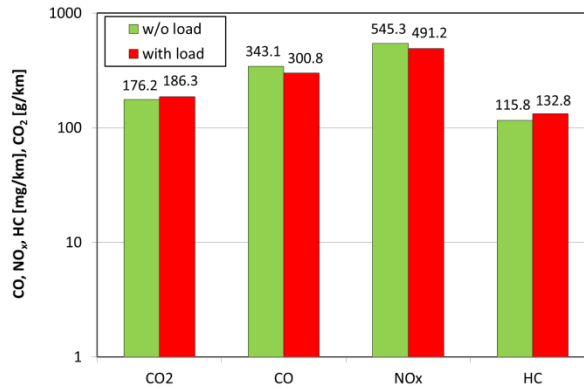

Fig. 7. Road emission during urban cycle tests

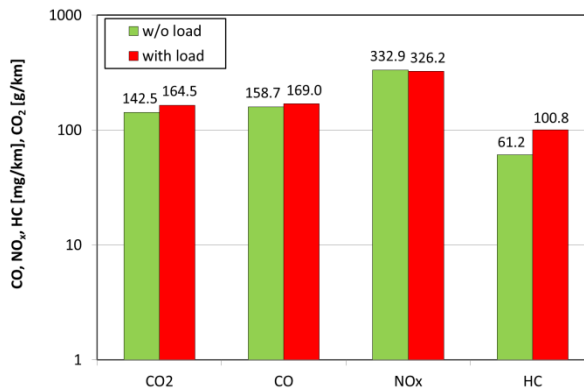

Fig. 8. Road emission during extra urban cycle tests

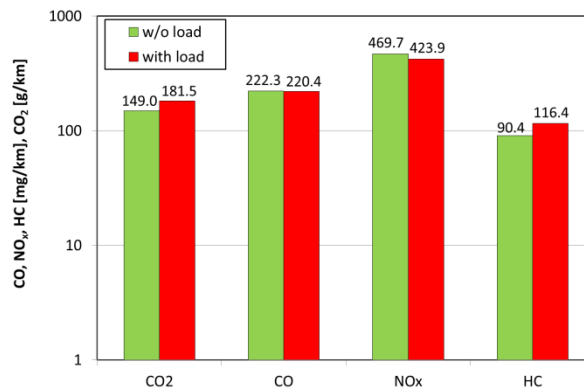

Fig. 9. Road emission during mixed cycle tests

The results of driving behaviour influence on fuel consumption and exhaust emission is shown on graphs 10 and 11. The verification of environmental aspects (emissions of carbon dioxide from the vehicle) of the application of the above-mentioned rules was made as a result of road tests of described above LDV. Test drives were carried out at the measuring section, free from traffic. The test vehicle accelerates to a speed of about 50 km/h, and then two ways of the speed deceleration were used. Inhibited using motion resistance while driving a rundown, in addition to using the brake system in the final stages of journeys made and using the gear ratios increase – gear reduction. In this analysis, there is the concept of the "drive" and "non-drive" phases of the vehicle motion – when the power is delivered to the wheels of the vehicle, or not supply.

In the case of carbon dioxide emitted by the tested car equipped with an CI engine, after obtaining the target speed and begin the process of deceleration can be seen a significant increase of CO<sub>2</sub> road emission in the event of engine idling (the drive is disconnected). In the case of

engine braking, the CO<sub>2</sub> road emission is much lower (Fig. 10). CO<sub>2</sub> road emission is corresponding with fuel consumption (Fig. 11).

Analysing the graph No. 10, it is possible to assume that slowing down with engine braking helps to reduce fuel consumption and exhaust emission of every analysed compound instead of NO<sub>x</sub>. This dependence is more complicated.

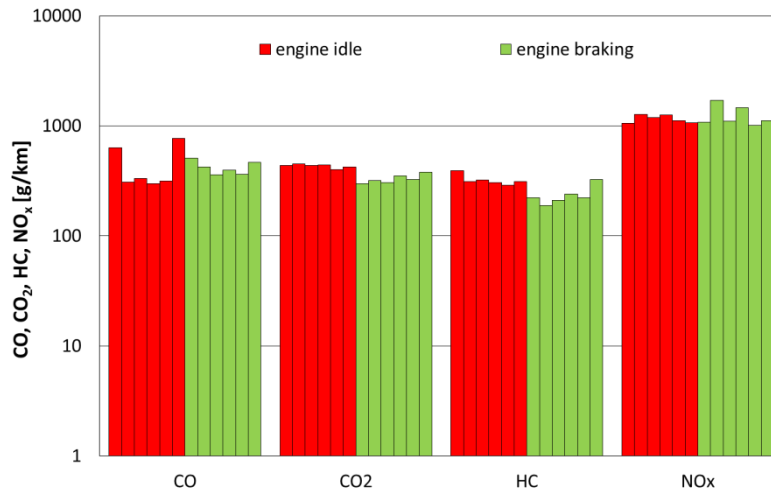

Fig. 10. Fuel consumption results during different methodology of slowing down

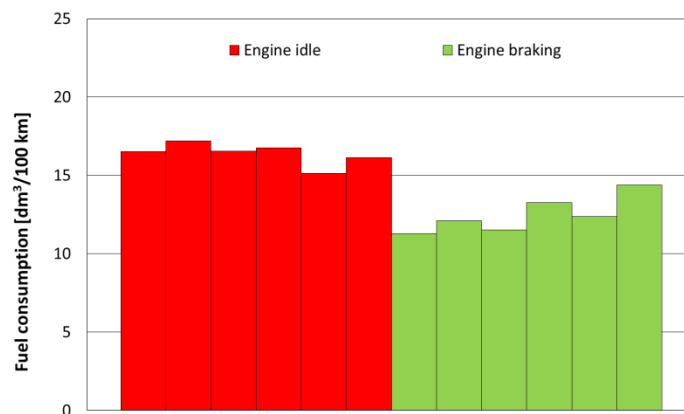

Fig. 11. Fuel consumption results during different methodology of slowing down

## 5. Summary

Conducted measurements allowed us to become quantitative information about the influence of vehicle load and driving behaviour on fuel consumption and exhaust emission. Mass of additional load in conducted measurements was about 400 kg, which is about 20% more than without additional load. In that case, the fuel consumption increase was about 6-20%. The influence of additional load in the vehicle on toxic compounds emission is other than expected. The higher engine load should lead to higher combustion chamber temperatures and thus should the NO<sub>x</sub> emission should be higher. It could be an effect of sophisticated engine management, but it should be proven by making more repetitions. In case of drivers behaviour, carried out tests showed the validity of the use of engine braking (downshifts) instead of driving a rundown during the operation of a motor vehicle. Not only that it avoids unproductive, from the standpoint of work efficiency, engine idling (lower mileage fuel consumption), it still achieved lower emission of harmful CO<sub>2</sub> and toxic CO, HC or NO<sub>x</sub> in the exhaust gases.

## References

- [1] The IEA-UIC *Railway Handbook on Energy Consumption & CO<sub>2</sub> Emissions* 2017 Edition, [https://uic.org/IMG/pdf/handbook\\_iea-uic\\_2017\\_web3.pdf](https://uic.org/IMG/pdf/handbook_iea-uic_2017_web3.pdf), 2017.
- [2] Schögggl, M., *Real Driving Emissions (RDE)*, Was steckt wirklich dahinter? AVL Emission TechDay2018, Mattsee, Austria 2018.
- [3] Engeljehring, K., *Emission Regulation Trends*, AVL Emission TechDay 2018, Mattsee, Austria 2018.
- [4] Rubino, L., Bonnel, P., Hummel, R., Krasenbrink, A., Manfredi, U., De Santi, G., *On-road emissions and fuel economy of light duty vehicles using PEMS: Chase-testing experiment*, SAE Technical Paper Series 2008-01-1824, 2008.
- [5] Merkisz, J., Pielecha, J., *Real Driving Emissions – vehicle test in variable terrain*, Journal of KONES Powertrain and Transport, Vol. 22, No. 1, pp. 217-226, 2015.
- [6] Andrzejewski, M., *Wpływ stylu jazdy kierowcy na zużycie paliwa i emisję substancji szkodliwych w spalinach*, Repozytorium Naukowe Politechniki Poznańskiej, Poznań 2013.
- [7] Merkisz, J., Kozak M., Andrzejewski M., *Wpływ sposobu rozpędzania samochodu ciężarowego na emisję dwutlenku węgla*, Combustion Engines, No. 3, 2013.
- [8] Merkisz, J., Andrzejewski, M., Pielecha, J., *The effect of applying the eco-driving rules on the exhaust emissions*, Combustion Engines, No. 4, 2013.
- [9] Andrzejewski, M., Merkisz-Guranowska, A., *A method of passenger car braking and carbon dioxide emissions*, Journal of KONES Powertrain and Transport, Vol. 22, No. 3, pp. 257-261, 2015.
- [10] <https://wego.here.com>, access: 10.07.2018.
- [11] SEMTECH-DS on-board, in-use emissions analyzer, Manual, Michigan 2007.

*Manuscript received 05 July 2018; approved for printing 05 October 2018*

