

SOLUTIONS IN THE VEHICLE SUSPENSION

Adrian Ioan Niculescu

*Institute of Solid Mechanics of the Rumanian Academy, Department of Dynamic Systems
Constantin Mille Street 15, 010141 Bucharest, Romania
tel.: +40 745187595, fax: +40 213126736
e-mail: adrian_ioan_niculescu@yahoo.com*

Antoni Jankowski

*Łukasiewicz Research Network – Institute of Aviation
Krakowska Av. 110/114, 02-256 Warsaw, Poland
tel.: +48 22 8460011, fax: +48 22 8464432
e-mail: antoni.jankowski@ilot.edu.pl*

Mirosław Kowalski

*Air Force Institute of Technology
Ksiecica Bolesława Street 6, 01-494 Warsaw, Poland
tel.: +48 261851303, fax: +48 261851313
e-mail: mirosław.kowalski@itwl.pl*

Tudor Sireteanu

*Institute of Solid Mechanics of the Rumanian Academy, Department of Dynamic Systems
Constantin Mille Street 15, 010141 Bucharest, Romania
tel.: +40 740176559, fax: +40 213126736
siretimsar@yahoo.com*

Abstract

The paper presents a review of the suspension solutions used on the street vehicle up to the now a days, finalising with presentation of their damping characteristics and with evaluation of their advantages or disadvantages. Long time the suspension systems have been dominated by the classic passive suspensions realized with metallic springs, shock absorbers with constant damping coefficients and anti-roll bars, excepting some luxury and sport cars using semi-active and active suspensions. There are presented some semi-active suspension solutions with continuous or discontinuous damping characteristics adjustment and the evolution of the Citroen and other active suspensions. All of them improve in some matter the performances but all of them have not ability to recuperate energy and has auxiliary energy consumption so last period the electromagnetically shock absorbers are researched, the paper presenting some of them. The paper also presents magneto rheological MR damper, solutions for adjustable passive shock absorbers and solutions for passive shock absorbers with variable damping coefficient with the stroke, e.g. Monroe Sensa Trac, Citroën Solution and VZN solution, with their damping characteristics and performances.

Keywords: *active suspension, semi-active suspension, comfort, stability, clearance, progressive cushions, VZN*

1. Suspension classification

The vehicle suspension has the role of assuring the vehicle body ground clearance. In addition, to eliminate the body and wheel oscillations generated by ground unevenness, external forces (aerial) and by the dynamic forces generated by vehicle trajectory changing and acceleration or

deceleration. Depending on the vehicle body weight suspension solution and solution for annihilate the vertical oscillations the suspensions classify according Fig. 1.

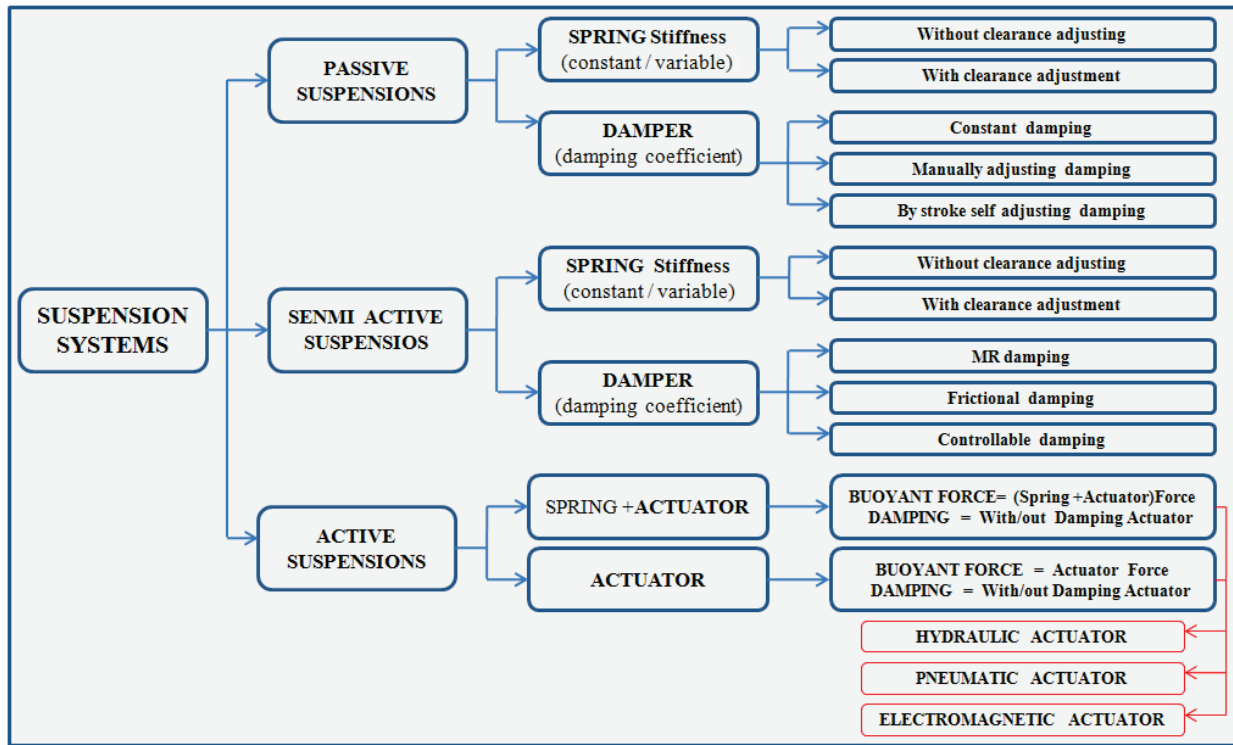

Fig. 1. Suspension classification

The passive suspension is the usually utilized and is realized with springs having constant or variable stiffness with the stroke and with hydraulic shock absorbers with constant damping coefficients, but in this category, there are some performing version e.g. springs permitting body ground clearance adjusting and shock absorbers with manual adjusting of the damping coefficient.

For improving stability and comfort where made semi-active suspensions using damper with variable damping coefficient changing continuously or discontinuously and springs having constant or variable stiffness but without active force.

Active suspension controls both the vertical movement of body and the wheels relative movement to the chassis to improve wheel-ground contact, to stabilize the body movements and to increase the comfort using an on-board system.

2. Active suspensions

A pure active suspension is one including an actuator that can generate active force to adjust body ground clearance and adjusting damping coefficient with algorithms using data from sensors attached to the vehicle.

For energy and cost economy some active suspensions uses springs to bear the vehicle weight and actuators only for controlling the dynamic evolution generated by running conditions. Other versions use only constant damping coefficients, not damping actuators.

We continue to present some solutions for active suspensions.

2.1. Suspension hydraulically actuated

The first active suspension known as *hydro pneumatic suspension* [1] was realized by Citroen Company, and was applied for the first time in 1954 on Citroen Traction Avant 15CVH. The

hydro pneumatic suspension principle [7] is presented in Fig. 2 and consists of a hydraulic system which fills or exhausts an oil cylinder by position of a hydraulic distributor, position correlated with the body ground clearance.

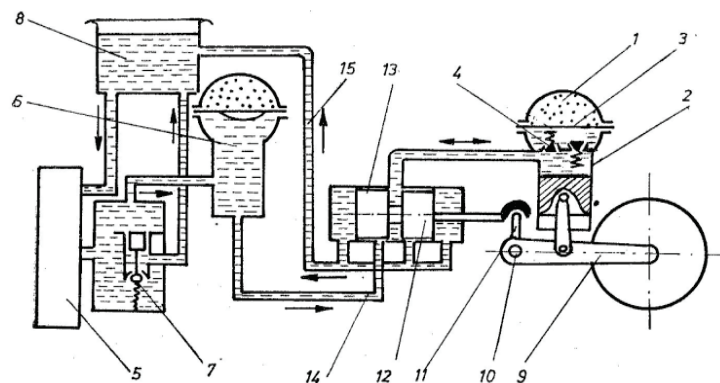

Fig. 2. Citroen hydro-pneumatic suspension principle [7]

The suspension system assures both self-levelling and driver variable ride height to adjust clearance according to the rough terrain. The system was applied until 1991 on Citroen DS and CX.

In 1988, Citroen Company launches the *hydroactive suspension* concept on the Citroen Activa adding electronic sensors and driver control of suspension performance.

Hydroactive 1 suspension systems had two user pre-sets, *Sport* and *Auto*, in the *Sport* setting the car's suspension in its firmest mode and in the *Auto* setting, the suspension was switched from soft to firm mode function of the speed in the accelerator pedal movement, brake pressure, steering wheel angle, or body movement, detected by one of several sensors.

Hydroactive 2 suspension systems, worked in two preset names *Sport* and *Comfort*, both settings reduced the thresholds significantly for any of the sensor readings allowing for a similar level of body firmness during cornering and acceleration, eliminating the ride scarification caused by the *Sport* mode in *Hydroactive 1* systems.

In 2001, Citroen has continued development of *Hydroactive* suspension with *Hydroactive 3* on Citroen C5 model, having two automatic modes:

- motorway position lowering by 15 mm of the vehicle height above 110 km/h,
- poor road surface position raising by 13 mm of the vehicle height below 70 km/h.

Further Citroen realized *Hydroactive 3+* suspension with three automatic modes:

- motorway position (lowering by 15 mm of the vehicle height above 110 km/h),
- poor road surface position (raising by 13 mm of the vehicle height below 70 km/h),
- comfort or dynamic suspension (by variation of the suspension firmness).

The *Hydroactive 3+* suspension calculates the optimum vehicle height, based: vehicle speed, front and rear vehicle height, rotation speed of steering wheel, steering wheel angle, vehicle's longitudinal acceleration, vehicle's lateral acceleration, suspension stroke speed, movement of the accelerator throttle.

2.2. Hydraulic suspension electronically actuated

This system consists of the steel springs hydraulic strut, high-pressure accumulator, hydraulic pump, dampers, sensors, electronic control unit. At system ABC – *active body control of Mercedes Benz* the sensors signals are analysed by an electronic unit that controls the oil flow into the spring struts at each wheel independently, compensating the road unevenness and thus reducing the body movement and slowly lowering the vehicle at higher speeds.

Figure 3 shows Mercedes Benz active body control ABC [2].

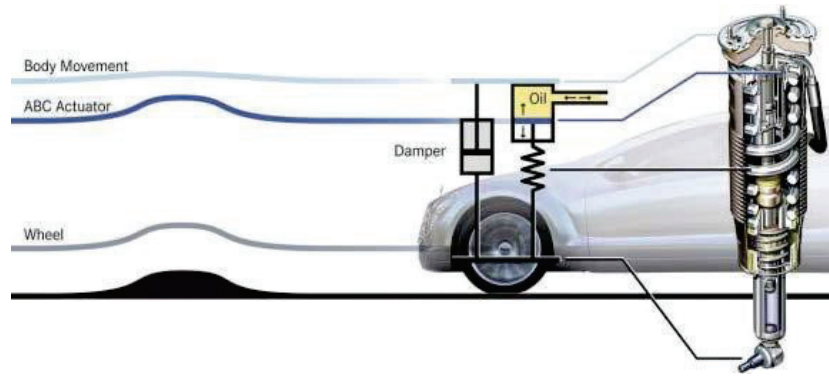

Fig. 3. Mercedes Benz active body control ABC [2]

2.3. Active antiroll control

BMW 545 developed an antiroll control (BMW-ARC) system by placing a hydraulic rotary actuator in the centre of the antiroll bar at the rear of the vehicle [2, 3], as shown in Fig. 4. The system is composed of a hydraulic pump with oil reservoir, lateral acceleration sensor, electronic control unit, hydraulic valve block, and two active stabilizer bars with rotating hydraulic actuators.



Fig. 4. BMW active anti roll control: a) BMW hydraulic active suspensions [2], b) hydraulic actuator schematic [2]

The system purposes are reducing roll angle during cornering, improving handling, agility, steering precision and eliminating the negative side effect of passive stabilizer bars.

2.4. The electromagnetic active suspensions versions

Active suspension system with electromagnetic actuator consist of spring and electromagnetic actuator arranged in parallel, they linking sprung and unsprung mass, the electro-magnetic actuator being a rotary motor or a linear motor. At rotary motor, the linear motion realization introduces system complications, increased mass and inertia. Comparative to hydraulic system the electromagnetic suspension system has next advantages: easy control of sprung and unsprung mass, no fluids, and works as generator reducing electric power consumption.

Usually at linear motor, what was a rotary stator becomes the forcer coil assembly, the magnet track remaining stationary, because the magnet track is greater, however, in short-stroke applications, their positions could be reversed – Fig. 5.

After decades of researches Dr Amar BOSE developed an electromagnetic active suspension dubbed the “digital chassis system” with improved dynamic behaviour (handling), improved stability, accurate force control, high-bandwidth operation controlling both sprung and unsprung masses, oil-free system, flexible controlling and energy regeneration due to reversible operation of the electromagnetic actuator in comparison with hydraulic active suspensions, the disadvantages in comparison with hydraulic active suspensions being increased volume and weight [6].

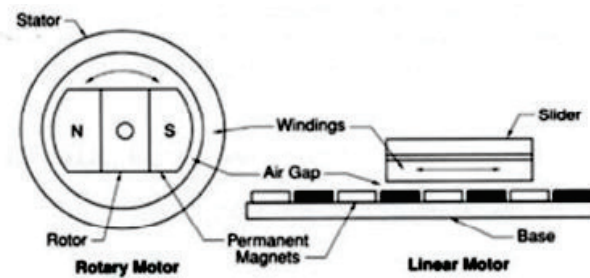

Fig. 5. Electro-magnetic rotary and linear actuator [2]

Figure 6 shows Bose electro-magnetic linear actuator [4], Bose front suspension [5] and schematic of vehicle with Bose active suspension [2].

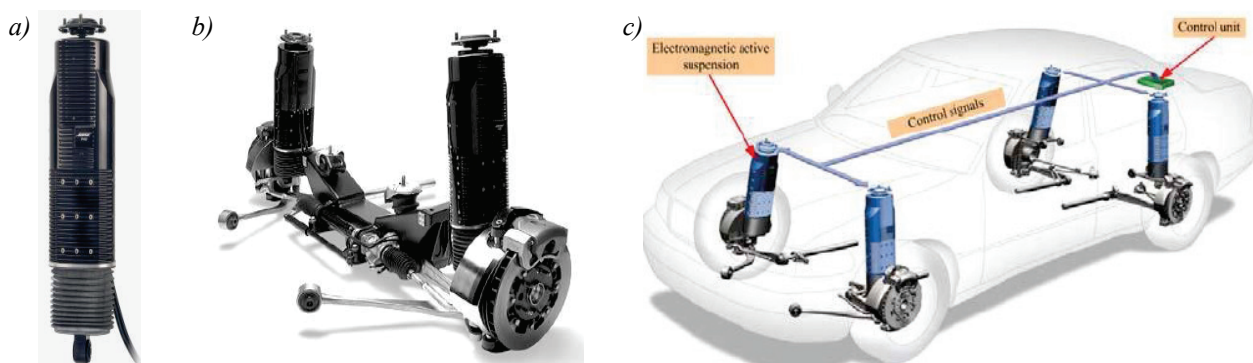

Fig. 6. Bose active suspension: a) linear motor [4], b) Bose front suspension [5]
c) schematic Bose active suspension [2]

3. Adaptive and semi-active suspensions

At adaptive or semi-active suspensions, the shock absorber can only change the damping coefficient and cannot correct clearance by adding energy in the suspension system.

Adaptive suspension needs a long time to modify damping coefficient and a short number of damping coefficient values, therefore, usually only propose different riding modes comfort, normal and sport, corresponding to different damping coefficients.

Semi-active suspensions react in few milliseconds and can provide a wide range of damping values modifying its in real time, function of the road conditions and the dynamics of the car.

In recent times, solutions in semi-active suspensions advance by adding advanced clearance control, thereby they approaching by fully active suspension.

3.1. Shock absorbers with solenoid actuators

These are the most economic and usual type of semi-active suspensions, changing the suspension damping characteristics with solenoid valve/s which control the fluid flowing inside dampers according commands send by a control unit, on the base of the various signals.

Figure 7 shows two solution changing damping characteristic in steps and another with continuous damping coefficient adjustment.

Version presented in Fig. 7a realises damping coefficient adjusting in two steps [8]. Working cylinder 1 opens by orifices 14 and 16 is placed in a communication cylinder 16, the fluid circulation between orifices 14, 16 is interrupted by seal collar 13 the link between these being realised only by solenoid valves 18a and 18b, one for rebound and other for compression. Function of the valves activate or inactivate state are realized two damping level for rebound and compression.

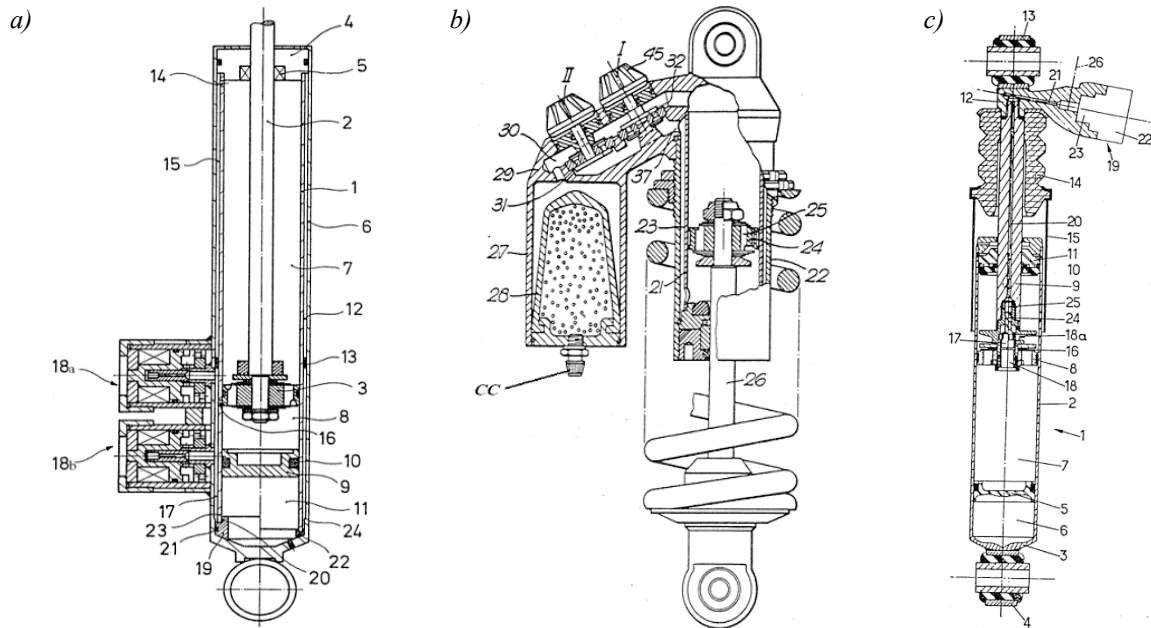

Fig. 7. Semi-active dampers with adjusting in steps and continuous: a) version with adjusting in two steps [8], b) version with sided balance chamber with adjusting in two steps [9], c) version with continuous adjusting [10]

Version presented in Fig. 7b. adjust damping coefficient on compression by knob I and o rebound by knob II, both placed in a body linked cylinder and balance chamber [9].

Version from Fig. 7c. realise damping coefficient adjustment by a constant damping valve 16 and a variable damping valve 17, controlled hydraulically through liquid from a channel 20-21, moved by a piston 23 powered by a solenoid valve 22. For fast reaction the variable damping valve 17 is excited permanent with rectangular signals of constant amplitude and frequency of 100 Hz, on these being superposes command signals modelled over time similar with hydropulse cylinder principle [10].

Figure 8 sows improving adherence by optimal damping coefficient changing [11].

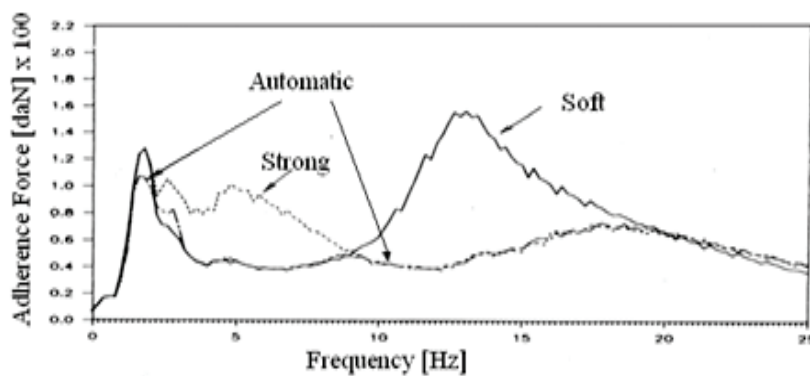

Fig. 8. Adherence force evolution function of the damping intensity

3.2. Magneto rheological damper

Magneto-rheological shock absorber is filled with magneto-rheological fluid whose flowing through calibrated channels/slots is controlled by the intensity of a magnetic field controlled at their turn by intensity of an electrical current whose magnification magnify the damping coefficient. There are many control possibilities such as skyhook or groundhook behaviour.

Figure 9 shows the two achievements versions, in left side version with damping channels and in rear side version with damping annular slot between piston and cylinder.

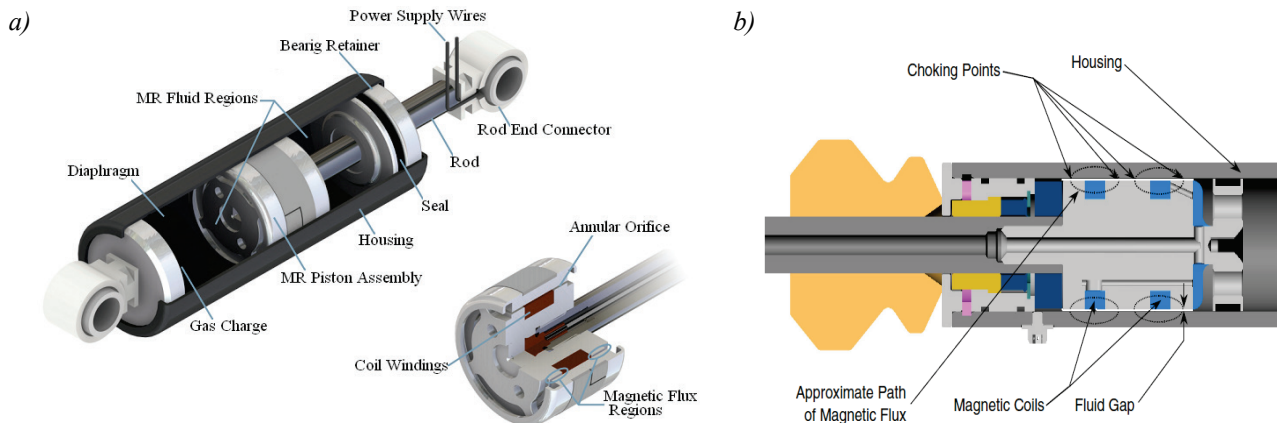

Fig. 9. Magneto-rheological dampers: a) MR damper with damping channels [12]
 b) MR damper with damping annular slot [13]

3.3. Advanced clearance control

Many companies improve passing capacity, stability and handling by static and dynamic body-ground clearance control. They realise this usually by adjusting the pressure of a pneumatic chamber realised with bellows, or sleeves, fastened between damper piston rod end and damper outer cylinder. Fig. 10 shows solution Quadra-Lift applied on Grand Cherokee [14].

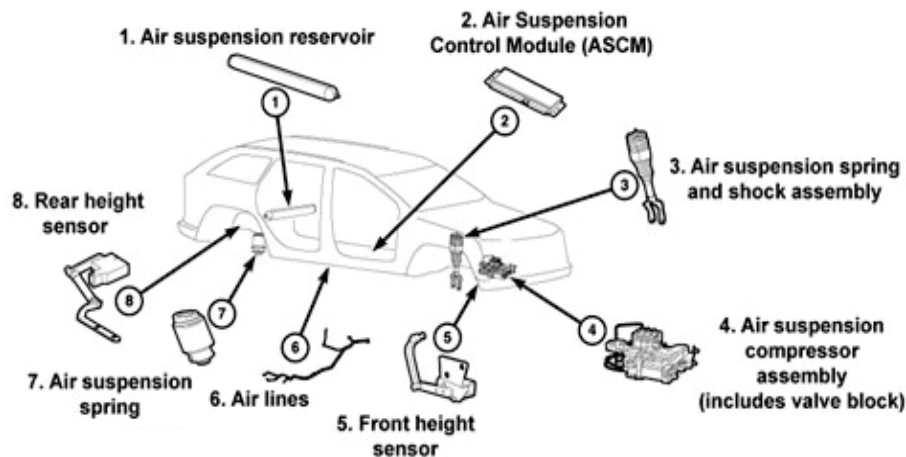

Fig. 10. Quadra-Lift air suspension system [14]

4. Passive suspension

Passive suspension consists of a spring and a shock absorber with:

- constant damping coefficients all the suspension ride:
 - without manual adjustment = classic suspension,
 - with manual adjustment = used in racing cars,
- variable damping coefficients function of the piston position relative to the ends.

4.1. Passive suspension with constant damping coefficient all suspension ride

4.1.1. Passive suspension without adjustment

Passive suspension consists of a damper and a spring, its simplicity, compactness, low weight and cost and high reliability, justify their utilisation on the majority of road vehicles. The disadvantages of passive suspensions are difficult to realise simultaneously the comfort and

handling performance, the designer selecting the damping coefficients and spring characteristics function the vehicle destination. Intelligent damping valves increase damper performances.

Usual the shock absorbers are realised with fluid but there are known solutions with friction.

Friction dampers consist of a friction element pressed by a tappet against housing, the damping force being generated by the relative movement between the housing and tappet. There are possible to realise diverse damping characteristics in function of the ride like, linear force progression characteristic, characteristics curves starting from soft and evolving with spring force, generating an ideal damper, the friction forces being dependent by temperature and relative speed. SUSPA Company realise all these kinds of shock absorber [15].

4.1.2. Passive suspension with manual adjustment

To improve passive suspension performances many companies realised shock absorbers with damping coefficient manually adjusting function of the road category and driving style, these being usually used in car competition, from this category Fig. 11 presents two versions of damper made by Ohlins Company and one made by Nitron Company and Fig. 12 presenting adjusting possibilities for Ohlins TT44 model.

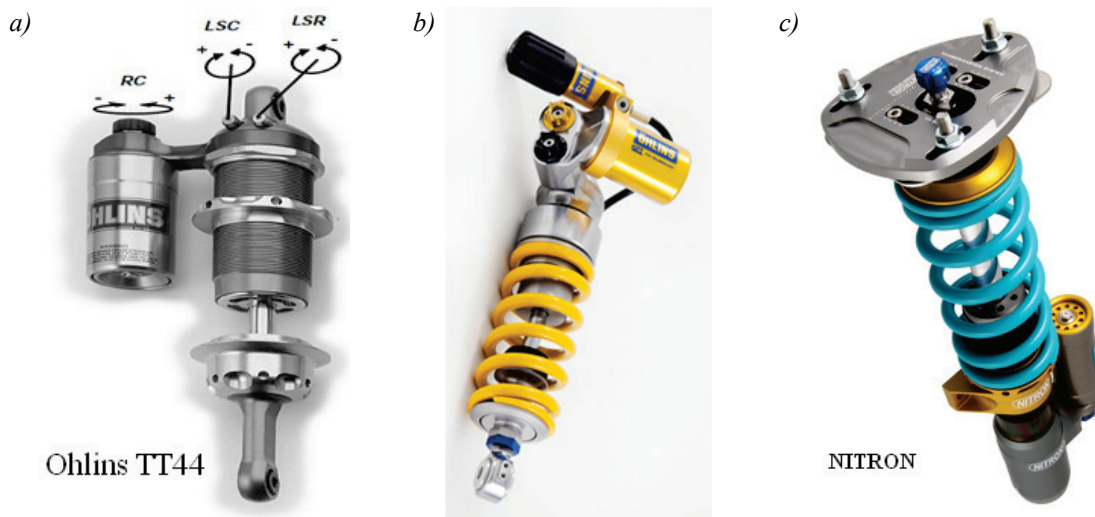

Fig. 11. Two Ohlins and one Nitron versions of shock absorbers with manually damping characteristic adjusting
 a) Ohlins TT44 [16], b) Ohlins TTX [17], c) Nitron R3 [18]

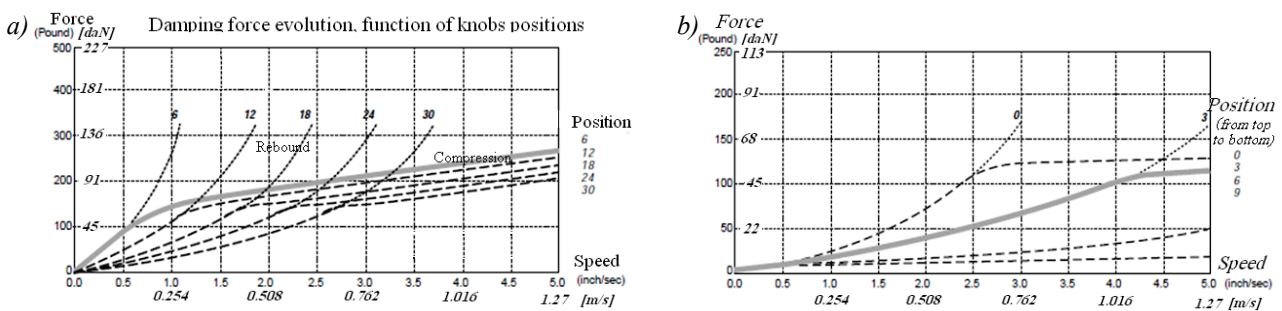

Fig. 12. Damping coefficients adjusting at Ohlins TT44 dampers: a) influence of rebound and compression knobs position in damping force adjustment, b) influence of fluid flowing in the balance chamber in damping force adjustment

By adjusting knobs LSC, LSR and RC, presenting in Fig. 11.a., Ohlins damper [16] realise 38 values for damping coefficient on compression, 38 on rebound (Fig. 12a.), these being multiplying on compression function of the RC knob position which adjust in 20-25 position (function of the numbers of plates pack) the fluid flowing in the balance chamber (Fig. 12b).

For body ground, clearance adjustment the spring will be fitting between an upper spring pad, fastened at the upper piston rod end, and a mobile spring pad fasten by a thread on the thread applied on the damper outer cylinder – Fig. 11a. (the spring is not presented in Fig. 11a).

4.2. Passive suspension with self-adjustment with stroke

4.2.1. Suspension with self-adjustment in the middle area of the stroke

In 1994 Monroe company release version Sensa Trac characterized by a thin through on inner face of working cylinder in its medium area, this generating a decreasing of damping coefficients in this medium area which increasing comfort effect on roads with small irregularities.



Fig. 13. Shock absorber Monroe Sensa Trac

4.2.2. Suspension with self-adjustment in the stroke ends

Figure 14 presents some main function positions of this model known as *suspension with progressive hydraulic cushions* [19, 20] equipped from 2018 vehicles Citroen C4 and C5.

The shock absorber works as normal one excepting the ends where the fluid is forced to flow through metering orifices whose number decrease when approach to stroke ends, generating progressive hydraulic brakes.

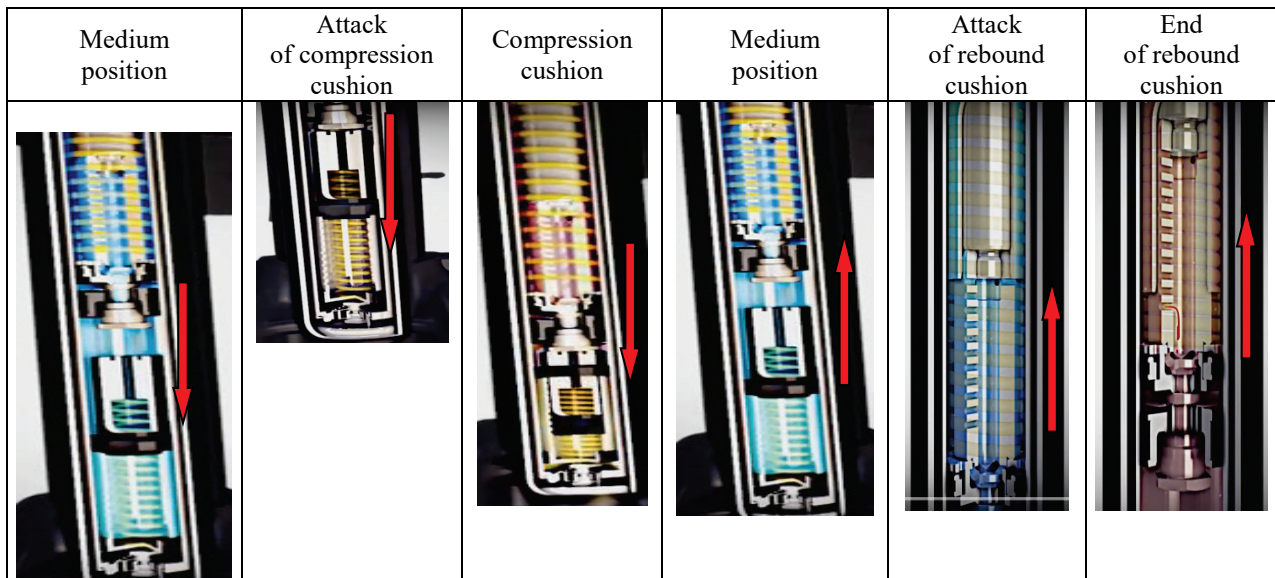

Fig. 14. Citroen dampers with progressive hydraulic cushions

4.2.3. Suspension with self-adjustment all stroke

For better performances *VZN concept* [21, 22] assures correlation of damping coefficient with vehicle load state and with ground unevenness by placing filling valves at working cylinder ends and spreading damping valves between ends, at cheap version the damping elements being metering orifices. Fig. 15 shows VZN damper principle and damping coefficients evolution with stroke for Standard, Monroe Sensa Trac, Citroen and VZN dampers.

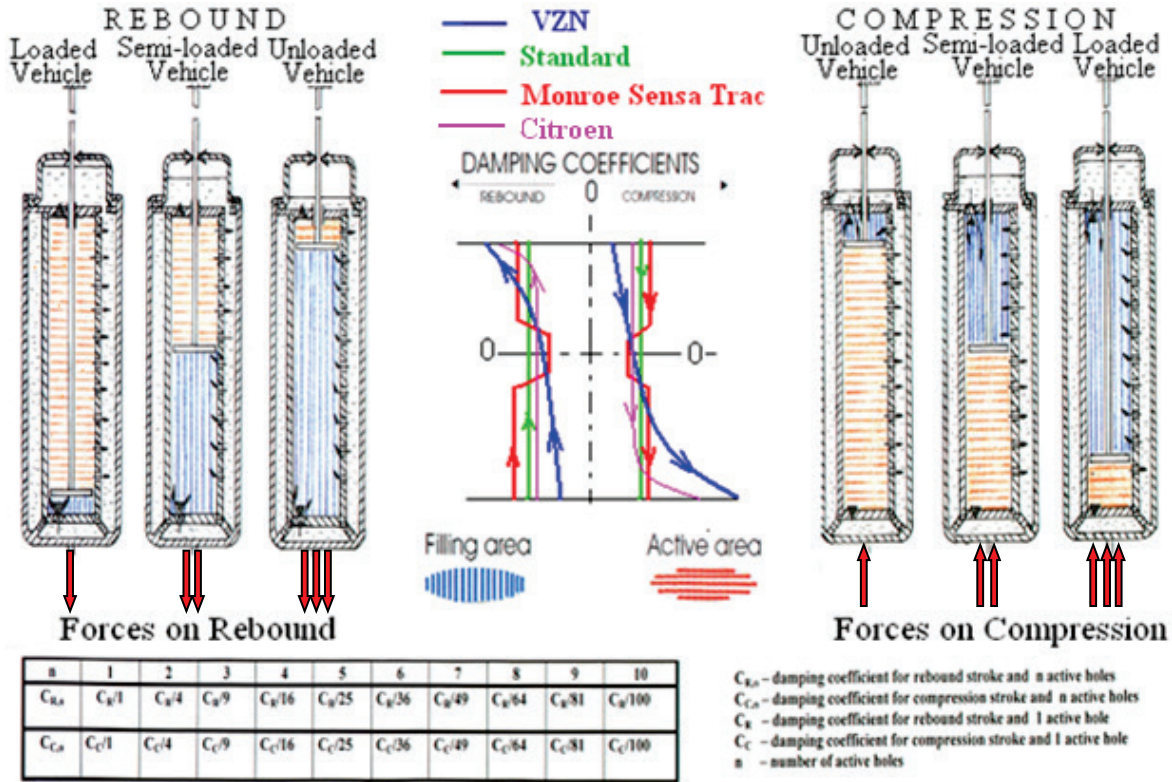

Fig. 15. VZN damper principle and damping coefficients evolution with stroke for Standard, Monroe Sensa Trac Citroen and VZN dampers

Figure 16 shows damping diagram Force-Stroke for Standard, Citroen and VZN shock absorbers at ± 75 [mm] stroke and 0.7, 0.9, 1.1, 1.3 [Hz] frequencies and ± 100 [mm] stroke and 0.3, 0.5, 0.7 [Hz]. VZN damping diagram is a real one, and others two are hypothetical reproducing only the shape not values. In diagram is presented the piston position for downloaded vehicle and fully loaded vehicle to evaluate the correlation between damping forces and vehicle weight.

Analysing Fig. 16 we observe at downloaded and fully loaded states Standard and Citroen dampers give the same damping forces while VZN has decreased damping forces at downloaded state giving increased comfort and at fully loaded increased damping force to increase stability.

Due to progressive damping force with stroke VZN concept gives the same, increased stability to roll [23] and pitch [24] comparative to Standard and Citroen dampers.

At stroke ends, only Citroen and VZN give hydraulic cushions.

7. Conclusions

There is a permanent evolution of all categories of suspension so passive suspensions realised with intelligent damping valves and trim suspension adjustment approaches by semi-active suspension performances and semi-active suspensions equipped with trim correctors approaches by active suspension performances.

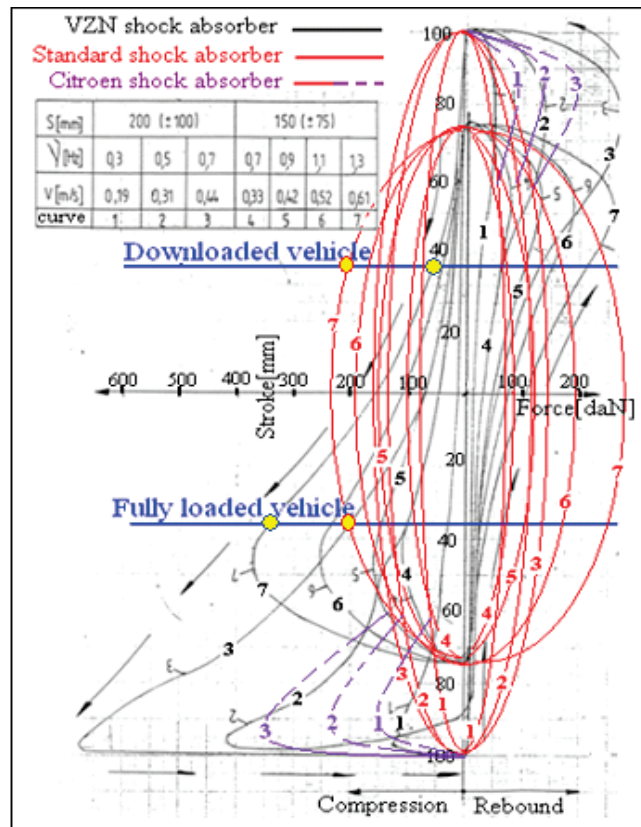

Fig. 16. Damping diagram Force-Stroke for Standard, Citroen and VZN dampers

References

- [1] Wikipedia, *Hydropneumatic suspension*, https://en.wikipedia.org/wiki/Hydropneumatic_suspension.
- [2] Mulla, A. A., Unaune, D. R., *Active suspensions future trend of automotive suspensions*, International Conference on Emerging Trends in Technology&Its Appliocations, ICETTA, 2013.
- [3] Strassberger, M., Guldner, J., *BMW's dynamic drive: An active stabilizer bar system*, IEEE Control Syst. Mag., Vol. 24, No. 4, pp. 28-29, 2004.
- [4] Howard, B., *Bose sells of its revolutionary electromagnetic suspension*, www.extremetech.com/extreme/259042-bose-sells-off-revolutionary-electromagnetic-suspension, 15.11.2017.
- [5] DiPietro, J., Automotive Editor, Edmunds.Com, *Bose suspension*, www.edmunds.com/car-technology/bose-suspension.html, 12.05.2009.
- [6] Gysen, B. L. J., Paulides, J. J. H., Janssen, J. L. G., Lomonova, E. A., *Active electromagnetic suspension system for improved vehicle dynamics*, IEEE Vehicle Power and Propulsion Conference, pp. 1-6, 2008.
- [7] Untaru, M., Seitz, N., Peres, Gh., Fratila, Gh., Potincu, Gh., Tabacu, I., Macarie, T., *Calculul si constructia automobilelor*, Editura Didactica si Pedagogica, Bucuresti 1982.
- [8] Ossner, F. W., *Brevet d'invention 2636697*, Institut National de la Propriete Industrielle 05.12.1989.
- [9] Verkuilen, A. H. I., *Patent Number 4,732,244/Mar. 22. 1988*, US Patent, 1998.
- [10] Willems, R. M., *Brevet d'invention 2643960*, Institut National de la Propriete Industrielle 06.03.1989.
- [11] Lizell, M., *Dynamic levelling for ground vehicles. A low power active suspension system with adaptive control*, Doctoral Thesis Department No. 91076 of Machine Elements, Royal Institute of Technology, Stockholm, Sweden 1990.

- [12] Poynor, J., *Innovative Designs for magneto-rheological dampers*, Advanced Vehicle Dynamics Laboratory, Virginia Polytechnic Institute and State University, <http://writing.engr.psu.edu/me5984/poynor.pdf>, 2002.
- [13] Lord Company, *How does an MR damper work?*, <https://www.lord.com/products-and-solutions/active-vibration-control/industrial-suspension-systems/how-does-mr-damper-work>.
- [14] Jeep Grand Cherokee, *Quadra-Lift Air Suspension system*, www.wk2jeeps.com/wk2_quadralift.htm, 2014.
- [15] Suspa Company, *Frictional dampers*, <https://www.suspa.com/in/products/friction-dampers>.
- [16] Ohlins Company, *Shock absorber*, Ohlins USA-Inside _TT44_Manual_p1.
- [17] Ohlins Company, *Shock absorber*, Ohlins TTX.
- [18] RCM – Roger Clark, Motorsport, *Nitron R3 Coilover Suspension System*, <https://rogerclarkmotorsport.co.uk/store/product/557-nitron-r3-coilover-suspension-system>.
- [19] Citroen Company, *Suspension with progressive hydraulic cushions*, <https://www.youtube.com/watch?v=qnTDbUCKhME>.
- [20] Citroen Company, *Tutorial – Progressive Hydraulic Cushions on SUV C5 Aircross explained*, <https://www.youtube.com/watch?v=sWOD-KgeypU>.
- [21] Niculescu, A. I., *Automotive Self Adjustable Damper With A Self Correcting Dissipation Characteristic*, European Patent EP 1190184, 2005.
- [22] Niculescu, A. I., *The self-adjustable shock absorber, with self-correcting damping characteristic, having curved, cylindrical and planar filling valves*, European Patent EP 2078168, 2011.
- [23] Niculescu, A. I., Sireteanu, T., Dumitriu, D., *Simulation results at some specific regimes, using shock absorbers with primary intelligence – VZN*, European Computig ConfereceVouliagmeni, Athens, Grece, September 2007.
- [24] Niculescu, A. I., Dumitriu, D., Sireteanu, T., Alexandru, C., *On “VZN” shock absorber concept performances*, F2008-03-010, FISITA World Automotive Congress, Munich 2008.

Manuscript received 10 August 2019; approved for printing 17 December 2019