

Ways of Eliminating the Road Effect in Transition Zones from the Railway Track to Bridge Structures

Zenon Zamiar, Andrzej Surowiecki, Piotr Saska

The International University of Logistics and Transport in Wrocław, Poland

Selected methods of constructing special inserts in the transition zones between the embankment of the railway track and the engineering object (bridge, viaduct, or culvert) were discussed. The purpose of mounting the designed inserts is to eliminate the so-called threshold effect, i.e. continuously creating a mild change in the stiffness of the ground under the track. In addition to the solutions presented in practice, attention was also paid to projects developed by the authors of this article. The results of experimental research constituting the basis for the development of some solutions are also given.

Keywords: railway track, engineering facility, transition zone, reinforcing inserts.

1. PROBLEM FORMULATION

Sections of the railway track in the contact area with the engineering object require special attention, as they are most often exposed to vertical deformations that result in damage to the surface. The reason for this undesirable phenomenon is the sudden change in track support stiffness (Fig. 1), leading to the difference between the nature of the track base work on the railway route and the track operation at the engineering facility. The jumping variability of track rigidity (called the threshold effect) is an important factor in increasing dynamic impacts and uneven track subsidence in the operation process and, as a result, increasing distortions in the "quiet" riding.

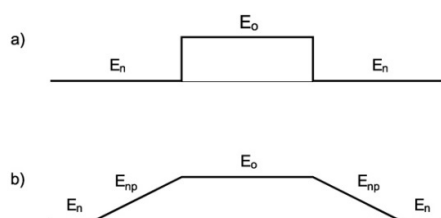

Fig. 1. Rigidity of the railway road foundation in the embankment-bridge transition zone [13]: *a* - threshold effect, *b* - recommended course of stiffness changes, E_n [MPa] - modulus of track base stiffness in the embankment, E_{np} [MPa] - linearly variable rigidity module, E_0 [MPa] - track substrate rigidity module on the bridge.

Actions reducing the "threshold effect" are aimed at ensuring continuity of the process of changing track rigidity when approaching from the deformable half-space of the embankment to the rigid bridgehead bridge structure (Fig. 1) [13]. Traditionally, this problem is eliminated using a concrete or reinforced concrete transition slab (uniform or openwork - practically more favourable due to the elimination of the phenomenon of so-called keying of the slab (i.e. randomly variable, unevenly distributed vertical displacements) in the soil centre. The slab, plunged in the ground massif, is supported with one end on the bridge abutment (in particular on the wall of the bearing niche - (Fig. 2) [2].

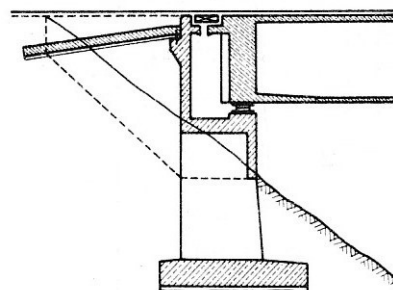

Fig. 2. The reinforced concrete bridgehead embedded in the embankment, having the shape of a retaining wall. Transition plate in the embankment, supported at one end on the wall of the bearing niche in the abutment [2].

The length of this plate depends, among others, on the expected amount of settlement of the embankment ground and traffic. The end of the plate should reach beyond the wedge of the fragment, so its length also depends on the height of the embankment [2]. The theoretical length of the slab can be determined on the basis of the classical method of calculating the soil pressure, developed by Ch. Coulomb [3]. Assumptions for the solution of Ch. Coulomb is given in Fig. 3 [3]. The force polygon E_c, Q, G shows that the pressure of the soil mass on the retaining wall (bridge abutment) is expressed by the relationship:

$$E_c = G \operatorname{tg}(\theta - \varphi') \quad (1)$$

in which:

G - weight of the fracture wedge (OAB triangle),
 φ' - angle of internal friction of the soil mass.

The weight of the fragment wedge is:

$$G = 0,5 \gamma h^2 \operatorname{ctg} \theta \quad (2)$$

Thus, the total pressure of the soil mass is determined as follows:

$$E_c = 0,5 \gamma h^2 \operatorname{ctg} \theta \operatorname{tg}(\theta - \varphi') \quad (3)$$

The extreme pressure condition requires the calculation of the first derivative of E_c after the value of the angle of inclination of the slip line θ to the level and equating this derivative to zero [3]:

$$\frac{dE_c}{d\theta} = 0,5 \gamma h^2 \{-\operatorname{tg}(\theta - \varphi') (\sin 2\theta)^{-1} + \operatorname{ctg} \theta [\cos^2(\theta - \varphi')]^{-1}\} = 0 \quad (4)$$

After solving the last equation, we get:

$$\theta = 0,25 \pi + 0,5 \varphi' \quad (5)$$

Finally, the fragment wedge length, characterized by the OA segment is:

$$OA = h \operatorname{tg}(0,5 \pi - \theta) \quad (6)$$

The OA parameter defines the minimum length of the transition plate according to [2].

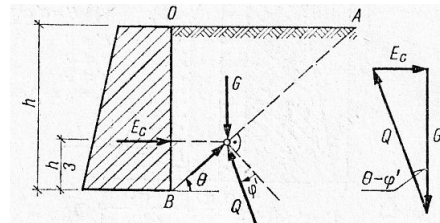

Fig. 3. Assumptions for the solution of Ch. Coulomb, concerning the determination of soil pressure on a retaining wall (in the present case the retaining wall is a bridge abutment) [3]. Marking: BA - slip line determined from the extreme pressure condition, OA - fragment wedge length, h - embankment height (height of bridge abutment).

As reported by F. Leonhardt [8], the slope of the plate 1: n (away from the bridge) should not usually exceed 1: 200, and in the case of high category communication routes 1: 300, so the settlement of the "sn" embankment, which is e.g. sn = 0.05 m would require a board with a length of L = 10 ÷ 15 m. In the manual [2] the following information is provided regarding transition plates:

- the slope of the slab should be greater, the more susceptible the surface of the traffic route (in this case the railway track) at the access to the bridge,
- the use of a transition plate is expedient especially in cantilever bridges or with abutments embedded in the embankment (Fig. 2).

According to J. Szczygieł [15], the length of transition plates should be at least 2.5 ÷ 3.0 m in average conditions, while at high embankments on railway lines up to 10.0 m.

The intensity of this "threshold effect" depends on many factors, including from:

- type of structure and size of the engineering structure (steel, composite, concrete structure, reinforced concrete, etc.; small, single or multi-span bridge, culvert),
- type of pavement on the bridge (e.g. railroad bed on ballast, bridge cranes or direct attachment of rails to the bridge structure),
- technical condition of the pavement on the bridge (characterized e.g. by geometric irregularities),
- the type and technical condition of the pavement structure in the vicinity of the bridge structure,
- the type and technical condition of vehicles and their speed and driving style (e.g. braking, acceleration),

- the type and state of compaction of the subsoil material in the embankment surrounding the bridge structure.

The type of structure and technical condition of the railway superstructure, the bridge structure and the subsoil in the vicinity of the bridge structure are associated with stiffness, which is a derivative of these characteristics. The measure of stiffness is e.g. the stiffness modulus [MPa].

It should be noted that "rigid" transition plates can be a source of so-called standing waves (reflected) and, consequently, undesirable resonance phenomena. Therefore, it is beneficial to strive to create a change in the rigidity of the substrate without separating the soil medium layers with rigid elements, e.g. using openwork panels.

Dynamic field measurements carried out at the Wrocław University of Technology [10] showed the effect of change in pavement stiffness on track sections about 10 m long in front of and behind the bridge structure. Therefore, the recommended (linear) start of the change in track stiffness (track gauge) should be at least 10.0 m in front of this object.

Sample results of measurements of vertical and horizontal track displacement amplitudes in the process of train passing through a reinforced concrete culvert with a rectangular opening are shown in Figures 4 and 5 according to [10]. The displacement amplitudes were determined in relation to the zero level, which is the equivalent of the unloaded state of the track. As a result of the research, it was found that at the location of the object and in the immediate vicinity the values of displacement amplitudes increase.

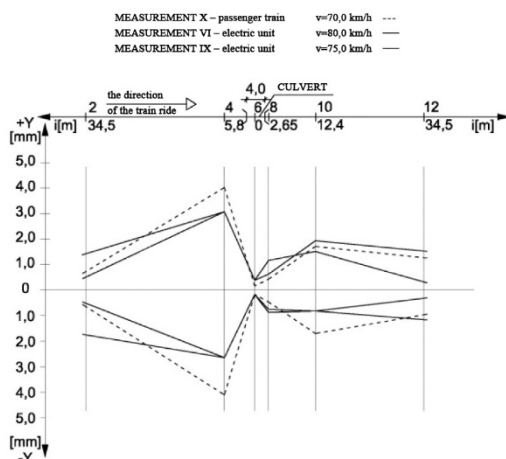

Fig. 4. Amplitudes of vertical track displacements within the culvert [10].

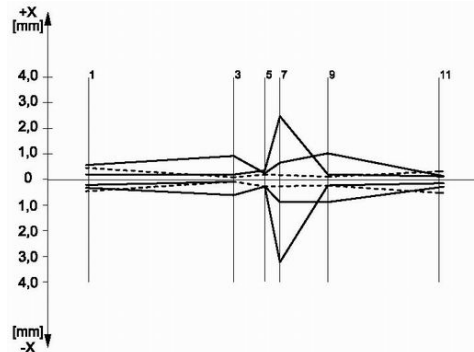

Fig. 5. Amplitudes of horizontal track displacements within the culvert [10].

With regard to railway bridges, the provision in paragraph 49 of the Regulation of the Ministry of Regional Development [11] is important. Paragraph 4 of this paragraph stipulates that "the track bed and pavement in the vicinity of the abutments should have a reinforced structure preventing different settlements caused by the difference of structural structures and the elasticity of the ground". The problem of track subgrade at engineering structures is also signalled in Technical Conditions Id-3 [4]. In this document (§7, sec. 5), in order to ensure a smooth change in the track-bed stiffness at engineering structures, it is mandatory to use transition sections in cases of:

- a newly constructed track bed on lines with planned speed of $v > 120$ km / h,
- modernized subgrade, in the process of adapting the existing railway line to the traveling speed $v > 160$ km / h,
- subgrade of existing railway lines, in cases of excessive threshold effects.

When designing the construction of transition sections according to Terms Id-3 [4], it should be taken into account (§23, sec. 1), among others: the type of structure of the engineering object, the height of the embankment at the access to the object, permissible operational differences in vertical displacements of the object and the embankment surrounding the object, system drainage at the facility and train speed.

2. SOME SOLUTIONS OF TRANSITION SECTIONS USED ON RAILWAY LINES

According to [17, 18], one of the solutions is laying under the pavement structure on the final sections of the bridge structure (at least 3.5 m long) mats of hardened foam, in order to adapt the rigidity of the pavement to the rigidity of the bridge structure. Behind the abutment, soil is stabilized with cement mortar (Fig. 6a, 6b). In these solutions (Fig. 6) there is a wedge of stabilized soil, the dimensions of which depend on the type and load capacity of the subsoil and should be determined depending on the difference between the vertical stiffness of the object and the subgrade.

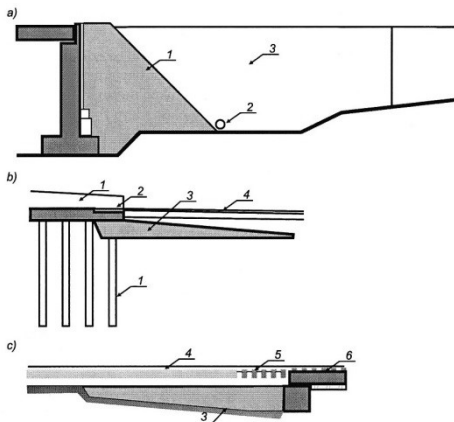

Fig. 6. Diagrams of transition track sections, laid between the bridge and the pavement on the railway route [17, 18]: a) 1 - earth embankment stabilized with cement mortar, 2 - drainage line, 3 - earth embankment; b) 1 - bridge structure, 2 - elastic layer, 3 - concrete slab or a layer of soil stabilized with cement, 4 - ballastless track surface, c) 3 - concrete slab or soil stabilized with cement layer, 4 - ballastless track surface, 5 - pavement with ballast layer, 6 - ballast pavement on the bridge structure.

In contrast, Annex 16 (Information) to Conditions Id-3 [4] gives examples of the construction of transitional sections of the track at engineering facilities, concerning cases of: the operating railway line, the newly built line for the speed of $v < 160$ km / h, and the newly built for $v > 160$ km / h. The possibility of increasing the effectiveness of these constructions is provided for by installing additional anti-vibration mats on bridge structures.

In practice, on the transitional sections of the lines in use, due to the limited possibilities to change the structure of the subgrade, the most commonly used is stiffening of the pavement and

strengthening of the upper layers of the subgrade [12]. Pavement stiffeners consist, for example, in: elongation of fenders existing on the bridge structure, installation of elongated sleepers at the bridge structure with track on the bridge cranes.

Strengthening the upper layers of the track-bed is carried out using:

- track protective layers in one- or many-layer system,
- transition plates reducing operational load, transferred to the subgrade ground,
- stone columns (these columns are holes with a diameter of about 0.30 m and a depth of about 2.0 m, filled with maximally compacted aggregate; the task of the columns is to strengthen weak soil of the track bed and improve drainage of the track bed).

Exemplary constructions of transition sections are illustrated in Figures 7, 8, 9, 10 and 11 according to [12].

In the manual [12] important guidelines for designing the track base at engineering objects are given. Here are some:

- track-bed materials embedded in transition sections should be easily compacted and be useful for cement improvement,
- due to track deflection (vertical displacement), it is expedient to use the same pavement on the bridge structure and outside it,
- track maintenance works (e.g. ballast cleaning, track positioning) that are carried out on railway routes should also be carried out along the length of the transition sections.- track-bed materials embedded in transition sections should be easily compacted and be useful for cement improvement,
- due to track deflection (vertical displacement), it is expedient to use the same pavement on the bridge structure and outside it,
- track maintenance works (e.g. ballast cleaning, track positioning) that are carried out on railway routes should also be carried out along the length of the transition sections.

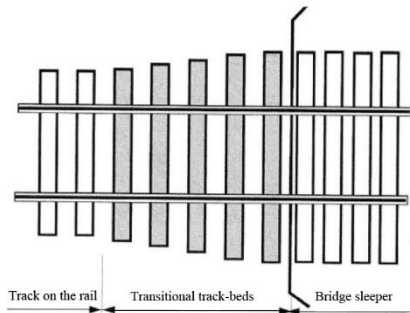

Fig. 7. Change in the length of the sleepers at the bridge structure creating a transition zone railway track-bridge [12].

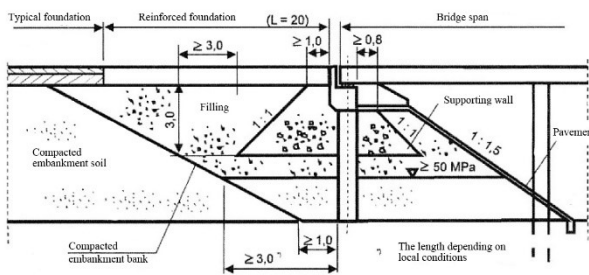

Fig. 8. Transitional section of the track in the embankment (French railways). In front of the bridge was used reinforced track foundation along the length of $L = 20$ m [12]

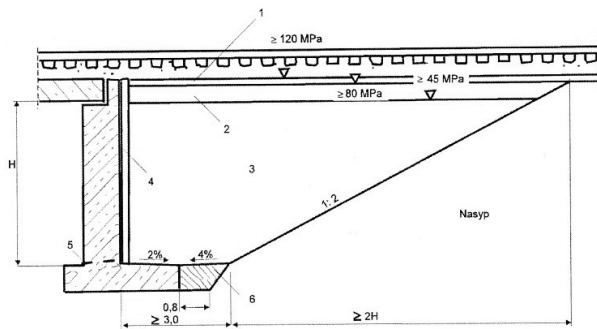

Fig. 9. Transition section of the track on the operating line (Hungarian railways) [12]: 1 - protective layer of the track, 0.20 m thick; 2 - foundation with a layer thickness of 0.50 m; 3 - well-grained soil ($U \geq 5$) compacted with layers of 0.15-0.30 m thick; 4 - insulation abutment and filter layer on the wall; 5 - drainage; 6 - concrete.

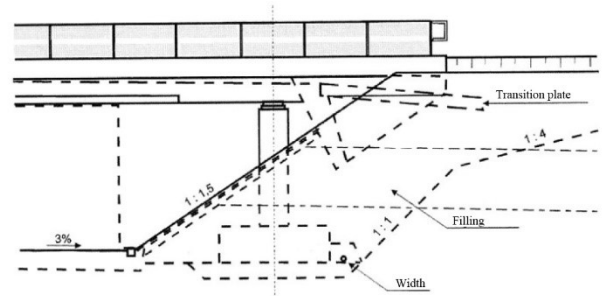

Fig. 10. Transitional section in the embankment of the newly built railway line with reinforced concrete slab (Finnish railways) [12].

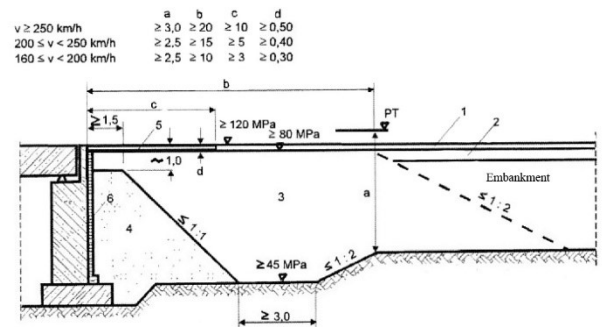

Fig. 11. Transitional section in the embankment of the newly built line (German railways) [12]: 1 - track protection layer, 2 - track foundation, 3 - well-grained soil ($U \geq 5$) compacted to $IS \geq 1.0$; 4 - soil stabilized with 3% cement addition and compacted to $IS \geq 1.0$; 5 - impermeable layer, 6 - wall abutment insulation and filter layer

3. PROPOSED SOLUTIONS FOR TRANSITION EPISODES

3.1. GENERAL THOUGHTS

Below there are proprietary solutions for the temporary construction of transition areas of the railway track with "stiffening" inserts. The special significance of these solutions is evident in crisis situations, when the success of the operation is determined by the speed of assembly, e.g. the process of rebuilding the access to the bridge damaged by the flood. The examples given are presented in three groups [13, 14, 15]:

1. Inserts made of stone material.
2. Inserts made of waste materials (elements).
3. Inserts forming the reinforced soil system (single or composite elements called mattresses).

3.2. STIFFENING INSERT AS A LAYER OF STONE MATERIAL

Fig. 12 illustrates a longitudinal view of an insert partially stiffening a railway pavement, constructed of stone aggregate as a macadam structure (aggregate layers of the same fraction) and located directly under the track ballast.

The insert has a variable thickness and consists of the following elements:

- at a length of 10 m adjacent to the bridgehead, made of broken stone with a thickness of 0.60 m and from the top it is "closed" with a layer of 0.15 m thick,
- directly at the abutment, the thickness of this layer is increased to 1.60 m,
- the second (extreme) section with a length of 10.0 m is a clinker layer with a thickness of 0.15 m.

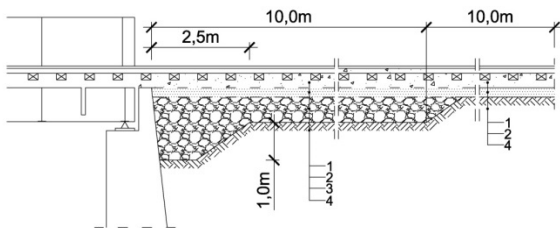

Fig. 12. Longitudinal section through a stiffening layer in the transition zone of a railway track - bridge structure made of stone material [13]: 1 - ballast, 2 - wedge 0.15 m (closing layer), 3 - broken stone pitch 0.60 m, 4 - embankment ground (subgrade)

3.3. INSERTS MADE OF WASTE MATERIALS

Waste materials can be used wooden or prestressed railway sleepers, used car tires and others. Fig. 13 schematically shows two examples of the construction of a stiffening layer (longitudinal section through a railway track) [13]:

- made of single sleepers, laid transversely to the track (Fig. 13a), located with a uniform longitudinal slope over the total length $L = 10.0$ m,
- made of single sleepers as before, but arranged in a 'three frets' system (Fig. 13b).

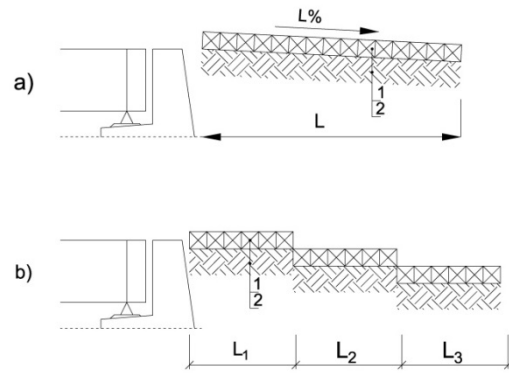

Fig. 13. Examples of constructing a stiffening layer made of railway sleepers [13]: a - the layer located with a longitudinal uniform slope, b - the layer in the "three thresholds" system, 1 - railway sleeper arranged transversely to the longitudinal axis of the track, 2 - subgrade.

Figure 14 illustrates an insert made of worn railway sleepers, constructed in the form of a grid (sleepers arranged perpendicularly and parallel to the longitudinal axis of the track and bridge) [13]:

- founded with a longitudinal slope uniformly over the total length $L = L_1 + L_2 + \dots + L_n = 10.0$ m (Fig. 14a), where $L_1 + L_2 + \dots + L_n$ are the lengths of individual sleepers located parallel to the longitudinal axis of the track and bridge,
- placed in the system of several thresholds (Fig. 14b).

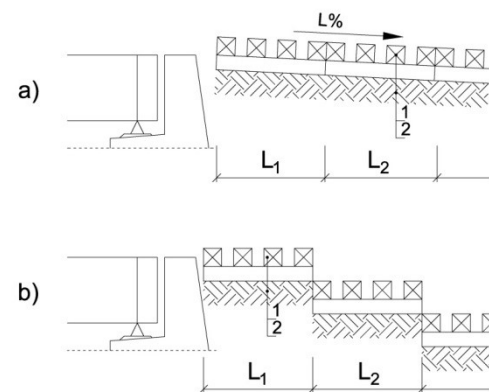

Fig. 14. Stiffening layer of worn railway sleepers, shaped as a grid [13]: a - a layer formed in a uniform longitudinal drop, b - a layer made in the threshold system, 1 - railway sleepers located transversely and longitudinally to the longitudinal axis of the bridge, 2 - ground of the track-bed.

3.4. INSERTS FORMING THE REINFORCED SOIL SYSTEM

There are various possibilities of constructing inserts increasing the rigidity of the soil medium, made on the basis of the idea of reinforced soil [5, 6, 7, 9]. Figure 15 shows examples of the following structures:

- a) individual reinforcing inserts in the form of meshes (steel meshes or plastic meshes with high tensile strength called geogrids) or grates, forming a system of external thresholds,
- b) inserts in a multilayer system, using internal thresholds,
- c) a "mattress" system, the coating of which is steel or polymer geogrids, while the stone aggregate is a filling.

Fig. 16 presents GEOWEB cell mats [5], made of welded geosynthetic strips. They are delivered in compact packages and stretched on the construction site into a multicellular "patch" with a height of 0.10-0.20 m. The cell mat is not laid directly on the ground, but on the previously laid intermediate geotextile. The granular material that fills the cells has a spreading effect on the individual walls of the patch. The essence of this system is to limit the freedom of lateral displacement of soil medium grains enclosed in the spatial cells of the patch, i.e. the GEOWEBU section. Low longitudinal deformation of the material (high density polyethylene) and its flexibility mean that after spreading the patch on a geotextile mat and filling the cells with well-compacted loose material, a spatial structure of reinforcement with horizontal mattress features is obtained. This structure can function as an independent resilient support layer. Figure 16 shows a top view of the GEOWEB cell mat layer and a view of the first mat layer after being filled with soil material [5]. It should be noted that the so-called GEOWEB cellular restriction system was already implemented in Poland in 1997 [6, 7]. This system was used on one of the 2-track main lines of Upper Silesia to ensure adequate load capacity of the subsoil of turnouts UIC 60 on pre-stressed concrete sleepers. Research on the accumulation process of permanent deformations of pavements in conditions of intense operational loads have shown the high effectiveness of the adopted solution.

In addition, GEOWEB mattresses are used to stabilize the deformable soil of railway tracks in mining damage areas [7].

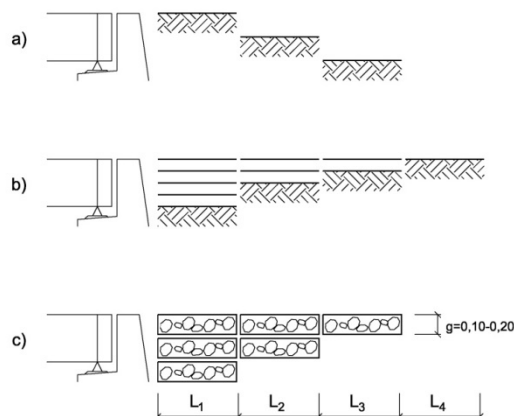

Fig. 15. Arrangement of inserts stiffening the railway track base (in longitudinal section), in the vicinity of the bridge structure [13, 14]: a - individual reinforcement inserts in the form of meshes (steel meshes or geogrids) or grilles; b - inserts in a multi-layer system, c - composite inserts forming a system of "mattresses" constructed of stone aggregate encapsulated with a special mesh coating.

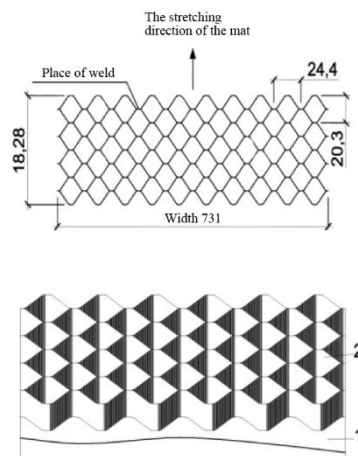

Fig. 16. Top view of the GEOWEB cell mat layer [5] and a view of the first mat layer after filling with soil; 1 - geotextile mat; 2 - GEOWEB mat

4. RESEARCH ON THE EFFECTS OF INCREASING THE TRACK-BED STIFFNESS WITH HORIZONTAL INSERTS

The possibilities of strengthening the non-cohesive soil medium (i.e. increasing the deformation modulus value) using special inserts were recognized by the authors of this article, based on physical models of the subsoil layer, made on a laboratory scale. The tests consisted in measuring vertical deformations of reinforced soil models (essentially sand), generated by vertical static load (Fig. 17). The samples were reinforced with FORTRAC® R90 / 90-20T polyester geogrids in the shape of a 0.50 m square. The main parameters of technical characteristics are as follows [1]: 20x20 mm square mesh size, tensile strength in the direction of the central axes min. 90 kN / m, maximum elongation at break in both directions 10%. Based on the estimated vertical deformations of soil samples, at external load (analogous to the operational load), in the form of vertical static pressure in the range of 0 ÷ 0.15 MPa, the deformation modules were calculated according to the formula (Table 1):

$$E_0 = p_z h s_v^{-1} \tag{7}$$

where:

- $p_z = 0.15$ MPa - maximum load of the soil sample,
- $h = 0.42$ m - sample height,
- s_v - vertical deformation of the sample.

The research was of the comparative character - the results were compared with the results obtained for the standard, i.e. the model without reinforcement. The values of deformation modules for some models are given in Table 1. An increase in the values of deformation modules of subgrade models (increase in stiffness) has been shown, depending on the number and arrangement of inserts.

In the case of models with reinforcement in the form of a "mattress", an additional enlargement of the deformation module by approx. 20% was found, compared to the analogous (in terms of location) reinforcement system with isolated inserts.

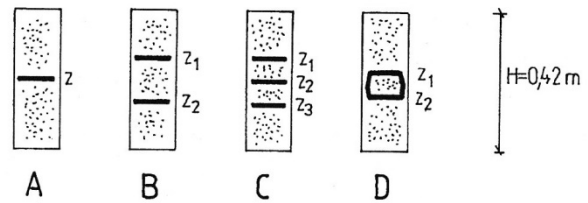

Fig. 17. Diagrams of research models: A - model with a single insert, B - with two, C - with three inserts, D - composite reinforcement in the form of a "mattress", H - height of the model, z - level of location of reinforcement inserts, index " n "with the parameter z means the reinforcement insert number [14].

Table 1. Values of deformation modules for selected models with isolated reinforcements. For comparison, the deformation modulus of the reference model (without reinforcement) was given [14].

Model	Location of reinforcement inserts [m]	Deformation module E_0 [MPa]
Single reinforcement	$z_1 = 0.03$	3.94
Single reinforcement	$z_2 = 0.09$	3.00
Single reinforcement	$z_3 = 0.15$	2.77
Single reinforcement	$z_4 = 0.21$	2.34
Single reinforcement	$z_5 = 0.27$	2.30
Single reinforcement	$z_6 = 0.33$	2.02
Single reinforcement	$z_7 = 0.39$	1.91
Double reinforcement	z_1, z_6	5.19
Double reinforcement	z_1, z_6	4.21
Double reinforcement	z_2, z_6	3.89
Double reinforcement	z_3, z_6	3.21
Double reinforcement	z_4, z_6	2.93
Double reinforcement	z_5, z_6	2.69
Double reinforcement	z_1, z_7	5.08
Triple reinforcement	z_1, z_4, z_7	5.90
Triple reinforcement	z_2, z_4, z_6	5.73
Triple reinforcement	z_3, z_4, z_5	5.47
unreinforced	-----	1.84

5. SUMMARY REMARKS

The subject of the article - in addition to the presentation of currently used transition episode solutions - are proprietary solution suggestions. These technologies can be classified as economical because they are characterized by features of significant importance (in relation to traditional reinforced concrete transition slabs), especially in the case of the need to quickly rebuild damaged (e.g. as a result of flooding) embankments adjacent to bridge structures. The advantages of these solutions include, among others: relatively short construction time and uncomplicated assembly

(which results in low implementation costs), no requirements for specialized equipment (components of the structure should be assessed as quite light) and qualified personnel.

It is necessary to emphasize the desirability of proposing the construction of transition inserts from used railway sleepers being waste materials. The recycling of used accessories proposed in the article is the most accurate solution in the light of the applicable environmental protection criteria.

Among the proposed transition inserts are also the three-dimensional GEOWEB cell-mats. The effectiveness of these strengthening inserts has been confirmed, among others in Upper Silesia, performing field tests on the deformation of the railway main track in the operation process, i.e. subjecting the track (with cell-mats in the ground) to dynamic operational load [6]. In addition, GEOWEB cell-mats are also used in practice to stabilize the railway track in mining damage areas [7].

One of the chapters of this article concerns own research carried out by the authors. In order to demonstrate the impact of the use of horizontally spaced reinforcing inserts on the growth of the subgrade deformation module, the results of tests performed on physical models of the layer of the soil loaded with static pressure were signalled in a synthetic form. Particularly noteworthy are the composite inserts (mattress type), which generated soil strengthening effects about 20% larger compared to the system of isolated inserts. The conclusions derived from these studies can be treated as a scientific pillar, justifying the advisability of the adopted concepts of transition zone development solutions.

REFERENCES

- [1] Ajdukiewicz J., *Rekonstrukcja i wzmocnienie podbudowy północnej jezdni autostrady A-4*, Raport Techniczny – po 5 latach. Przedsiębiorstwo Realizacyjne INORA® Sp. z o.o., Gliwice 2004.
- [2] Czudek H., Jaworowska B., Pisarczyk S., Radomski W., *Budowa mostów*, vol. 1, Wydawnictwa Szkolne i Pedagogiczne, Warszawa 1993.
- [3] Dembicki E., *Parcie, odpór i nośność gruntu*, Wydawnictwo Arkady, Warszawa 1999.
- [4] Id-3 Warunki Techniczne Utrzymania Podtorza Kolejowego, PKP Polskie Linie Kolejowe S.A., Warszawa 2009.
- [5] Jarominiak A., *Lekkie konstrukcje oporowe*, Wydawnictwa Komunikacji i Łączności, Warszawa 2010.
- [6] Kłosek K., Gad P., Wróbelki W., *Wykorzystanie GEOWEBU do wzmocnienia słabonośnego podtorza rozjazdów na podrozjazdnicach betonowych*, [in:] *IX Konferencja Naukowa „Drogi Kolejowe”*, Kraków, Politechnika Krakowska, Wydział Inżynierii Lądowej, Kraków 1997, pp. 99-110.
- [7] Kłosek K., *Wzmacnianie podtorza górniczego geosyntetykami*, „Przegląd Komunikacyjny”, 31 (2016)/11, pp. 27-30.
- [8] Leonhardt F., *Podstawy budowy mostów betonowych*, Wydawnictwa Komunikacji i Łączności, Warszawa 1982.
- [9] Mazur S., Surowiecki A., *Opracowanie sposobu zabudowy warstwy wzmacniającej z gruntu zbrojonego na przejeździe kolejowo-drogowym*, Boreczek-Strzelin, Raport Serii SPR, No. 15, Instytut Inżynierii Lądowej, Politechnika Wroclawska, Zlecenie Nr 311869 DDOKP, etap I., Wrocław 1986.
- [10] Piotrowski A., Surowiecki A., *Strefa przejściowa toru kolejowego w obrębie przepustów*, [in:] *Materiały III Konferencji Naukowo-Technicznej „Drogi Kolejowe”*, Politechnika Krakowska, Kraków-Muszyna, 3-5 października Kraków 1985, vol. 2, pp. 109-119. 1985.
- [11] Rozporządzenie Ministra Infrastruktury i Rozwoju z dn. 5.06.2014 r. zmieniające rozporządzenie w sprawie warunków technicznych jakim powinny odpowiadać budowle kolejowe i ich usytuowanie. Dz.U. RP, Warszawa, 30.06.2014, pos. 867.
- [12] Skrzyński E., *Podtorze kolejowe*. ZPK, WAT, PKP PLK S.A., Kolejowa Oficyna Wydawnicza, Warszawa 2010.
- [13] Surowiecki A., *Sposoby likwidacji efektu progowego w strefach przejściowych z dróg na obiekty mostowe*, [in:] *Materiały IV Krajowej Konferencji Naukowo-Technicznej „Problemy projektowania, budowy i utrzymania mostów małych”*, 2-3.12.1999, Politechnika Wroclawska, GDDP, ODZMRP, Dolnośląskie Wydawnictwo Edukacyjne, Wrocław 1999.
- [14] Surowiecki A., *Designing of intermediate zones from the local roads to engineering objects*, „Zeszyty Naukowe Akademii Rolniczej we Wrocławiu. Geodezja i Urządzenia Rolne”, 379 (2000)/16, pp. 131-141.
- [15] Surowiecki A., *Modernizacja konstrukcji dróg szynowych.. Badania modelowe i eksploatacyjne*, Wydawnictwo Wyższej Szkoły Oficerskiej Wojsk Lądowych im. gen. Tadeusza Kościuszki, Wrocław 2012.
- [16] Szczygieł J., *Mosty betonowe*, Wydawnictwa Komunikacji i Łączności, Warszawa 1978.
- [17] Towpik K., *Koleje dużych prędkości. Infrastruktura drogi kolejowej*, Oficyna Wydawnicza Politechniki Warszawskiej, Warszawa 2012.

- [18] Towpik K., *Infrastruktura transportu szynowego*, Oficyna Wydawnicza Politechniki Warszawskiej, Warszawa 2017.

Zenon Zamiar
The International University of Logistics and
Transport in Wrocław, Poland
zzamiar@msl.com.pl

Andrzej Surowiecki
The International University of Logistics
and Transport in Wrocław, Poland
andrzejsurowiecki3@wp.pl

Piotr Saska
The International University of Logistics
and Transport in Wrocław, Poland
Piotr.Saska@awl.edu.pl