



ANALYSIS OF THE FLOW CHARACTERISTICS OF ENERGY DISSIPATING STRUCTURES IN DAM SPILLWAYS BY CFD METHOD

Kenan Büyüktaş, Ahmet Tezca, İmran Sajid, Suna Büyükkök
Akdeniz University, Antalya, Turkey.

Abstract

During flow of water from upstream to downstream in a controlled manner, the flow of water at high velocity and pressure, which occurs as a result of hydraulic jump is broken by energy dissipation structures in relief or accumulation structures. Otherwise, the flow of water with high velocity and pressure in the downstream section, where the stream passes from a flood regime to a river regime, will damage its own structure and surrounding environment. For this reason, it is necessary to design energy-dissipating structures at appropriate locations with appropriate sections so that large pressure and friction forces do not cause abrasion and erosion in flow chamber.

In this study, flow characteristics such as pressure distribution, outlet flow, velocity distribution etc. of the water flowing from a dam in-fill located in Adrasan town of Antalya province was determined. Then, dam spillway was modelled in the computer environment with the actual measurements and analyzed according to Computational Fluid Dynamics method (CFD) using ANSYS-Fluent software. Finally, the actual measurements were compared with the simulation results. Additionally, measured data were compared with the downstream flow characteristic by defining to dam and spillway projecting software of General Directorate of State Hydraulic Works (pro-SHW).

As a result, the current dam spillway values are similar to the simulation values. It is clear that the CFD method provides the convenience

of users and institutions in sizing and calculating the flow characteristic before projecting large fixed constructions which has high cost.

Keywords: CFD, dam, energy dissipating structure, simulation, spillway

INTRODUCTION

Energy dissipating structures in apron decrease the energy of water in high velocity and pressure occurred during transfer to downstream from the upstream in water relief and gathering structures. Otherwise, water flow with high velocity and pressure in downstream where the flow passes to river regime from the flood regime will damage the structures. For this reason, energy dissipating structures should be planned at appropriate locations and sections so that large pressure and frictional forces do not cause cavitation and abrasion in flow chamber (Anonymous 2012).

Because energy dissipating structures are mainly dependent on project location, many research have been done in this area but project standard of these have not completed yet. In this respect, model studies and hydraulic studies should be examined before preparing exact project of such a structure. Undoubtedly, projecting of energy dissipating structures requires great work and skill (Aküzüm ve Öztürk 1996; Erkek ve Ağralıoğlu 2013).

Computational Fluid Dynamics (CFD) is currently being evaluated as a subdivision of Fluid Mechanics. CFD method is defined as solution method with numerical algorithms of the problems originating from the flow. Especially after the 1990s, the use of CFD method is increasingly observed. The main reasons for this are that computer capacities are increasing day-to-day, high cost of experiment and experiment materials and the duration of the product design with experiment and test is kept long time (Wislicenus 1964, Ferziger ve Peric 2002).

In general CFD is a method used to analyze all kinds of fluids and flows in different conditions. In this method, basically three main equations (continuity, momentum and energy equations) are taken as basis and it is reached to pressure, velocity, temperature distribution and many data depending on these parameters by solving these equations numerically (Wislicenus 1964, Ferziger ve Peric 2002).

In this study, flow characteristics such as pressure distribution, outlet flow and velocity distribution of the water flowing from a dam infill located in Adrasan town of Antalya province was determined. Then, dam spillway was modelled in the computer environment with the actual measurements and analyzed according to Computational Fluid Dynamics method (CFD) using ANSYS-Fluent software. Finally, simulation results were compared with the downstream flow characteristic by defining to dam and spillway projecting software of General Directorate of State Hydraulic Works (pro-SHW).

MATERIAL AND METHOD

In this study, it was investigated the efficiency of the energy dissipating structures in the stilling basin and how the energy of the flowing water from the dam spillway located Adrasan town of Antalya province changed throughout the stilling basin. Dam and data belong to dam spillway, pro-SHW, ANSYS and SolidWorks software were used as material in the study. Dimensions of spillway and elements such as chute blocks, energy dissipating structures and stilling basin were determined according to pro-SHW. Additionally, type of stilling basin were also determined as Type III according to pro-SHW. Spillway views belong to spillway were given in Figure 1. Precipitation area of lake used in study is 4.72 km² and annual average flow is also 7.493 hm³/year. Various data belong to dam lake, dam and spillway were given below.

Lake

Maximum water level	: 149.67 m
Normal water level	: 147.84 m
Minimum water level	: 114.73 m
Lake volume in maximum water level	: 3.137 hm ³
Lake volume in normal water level	: 2.817 hm ³
Lake volume in minimum water level	: 0.059 hm ³
Active volume	: 2.758 hm ³
Amount of water to be given to the irrigation	: 4.088 hm ³
Lake area in maximum water level	: 178 933 m ²
Lake area in normal water level	: 168 434 m ²
Lake area in minimum water level	: 14 200 m ²

Body

Spillway

Purpose	: Irrigation	Design flow	: 120.94 m ³ /s
Parapet Wall Upper Level	: 150.75 m	Outlet flow	: 52.33 m ³ /s
Crest elevation	: 148.25 m	Crest elevation	: 147.84 m
Talweg elevation	: 100.50 m	Crest width	: 10 m
Altitude from talweg	: 47.75m	Type of energy dissipating	: Type-II
Altitude from base	: 50.00 m	Stilling basin length	: 19.00 m
Crest width	: 8.00 m	Wall height of stilling basin	: 6.75 m
Crest length	: 278.42 m		

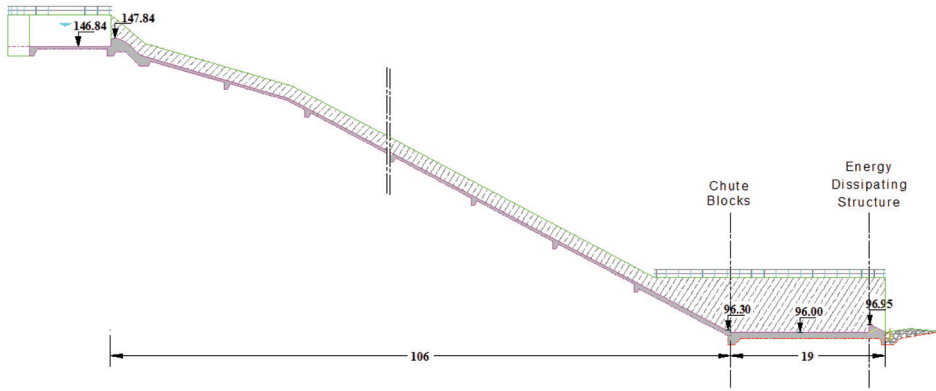

a) Cross-section view of dam spillway

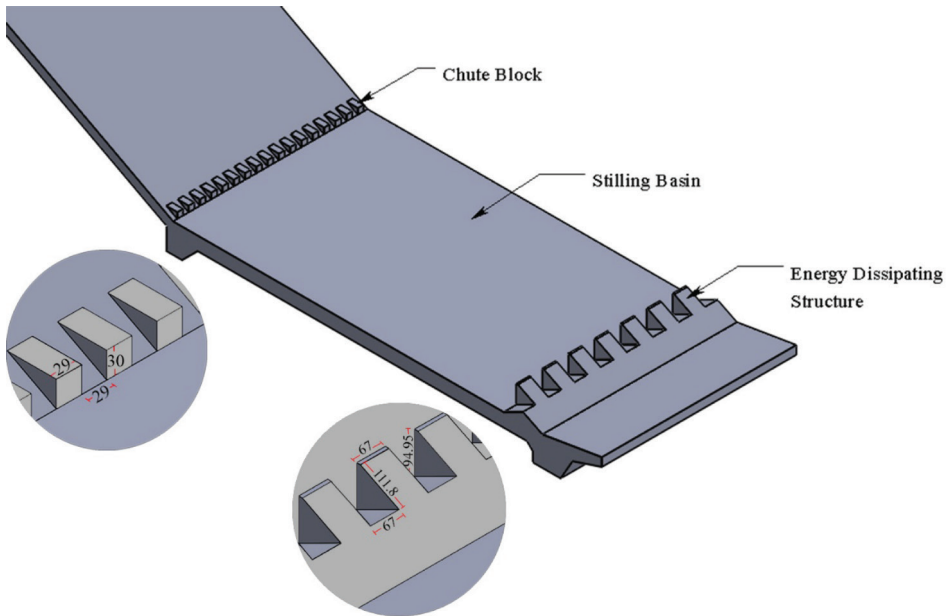

b) Detail view of stilling basin

Figure 1. Views belong to spillway and stilling basin

The model of spillway was created in ANSYS software by using data belong to dam and spillway. Then mesh were defined to the model which was created. Number of mesh was determined with pre-analysis according to CPU performance. Number of mesh used in this study is 1467818 (Figure 2). Analyze was started by defining boundary and initial conditions to the software after

mesh generation. Results of analyze were compared and interpreted with the project results and data obtained from pro-SHW software.

Then, compliance level between calculated values and simulated vales were determined by using Equation 1.

$$Error = \left[\left(\frac{\sum_{i=1}^n C_i - \sum_{i=1}^n S_i}{\sum_{i=1}^n C_i} \right) * 100 \right] \quad (1)$$

Here,

C_i : Calculated values

S_i : Simulated values

n : Number of samples

If values which obtained from the Equation 1 is small, error ratio is less. Error ratio that is smaller shows that compliance level between simulated and calculated values are better.



Figure 2. View of mesh of the model

RESULT AND DISCUSSION

Velocities, water depths and flows before chute blocks and after sill were determined by taken measurements in some certain coordinates in model and were investigated changes of these velocities, water depths and flows. Velocity

distribution and velocity magnitude throughout the spillway body obtained from ANSYS-Fluent simulation were given Figure 3 and Figure 4, respectively.

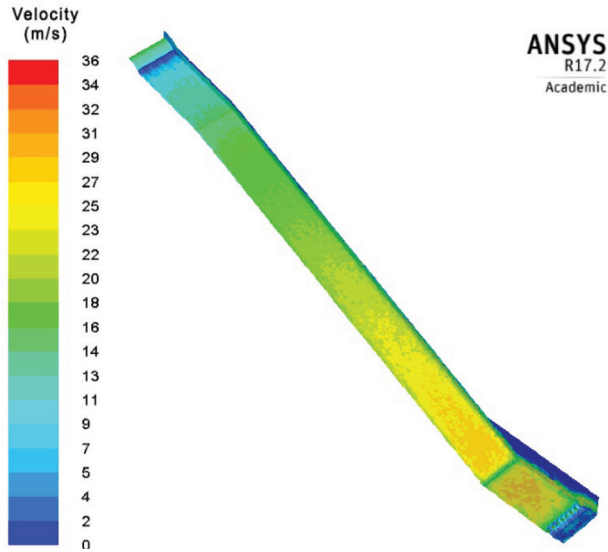

Figure 3. Velocity distribution throughout the spillway body

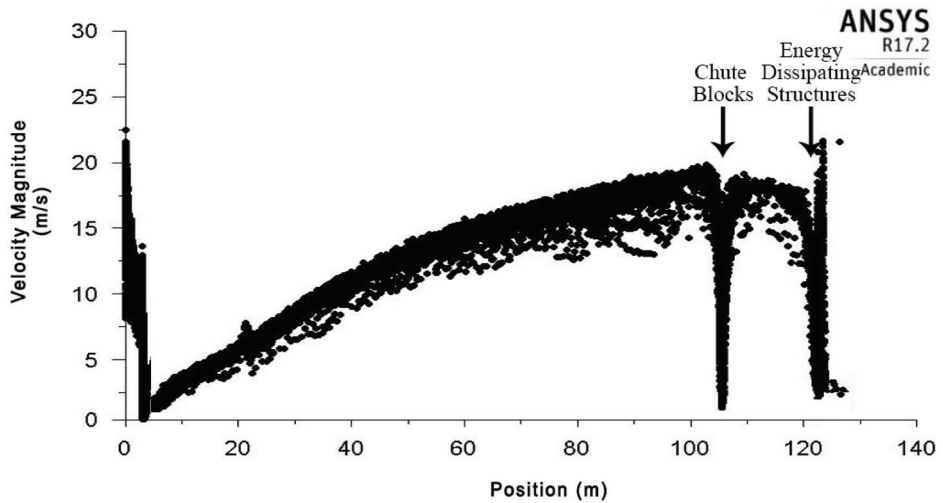

Figure 4. Velocity magnitude simulated using ANSYS-Fluent throughout the spillway body

When the changes of velocity values according to spillway body is examined (Figure 4), water velocity increases up to chute blocks and decreases after chute blocks, velocity values in the stilling basin decreases also after energy dissipating structures. As it is shown from Figure 4 that while velocity is increasing up to 19 m/s, it is nearly 1.3 m/s in the chute block level and additionally, it is 2 m/s after the energy dissipating structures. These values shows similarities the values calculated with pro-SHW by General Directorate of State Hydraulic Works (Table 1).

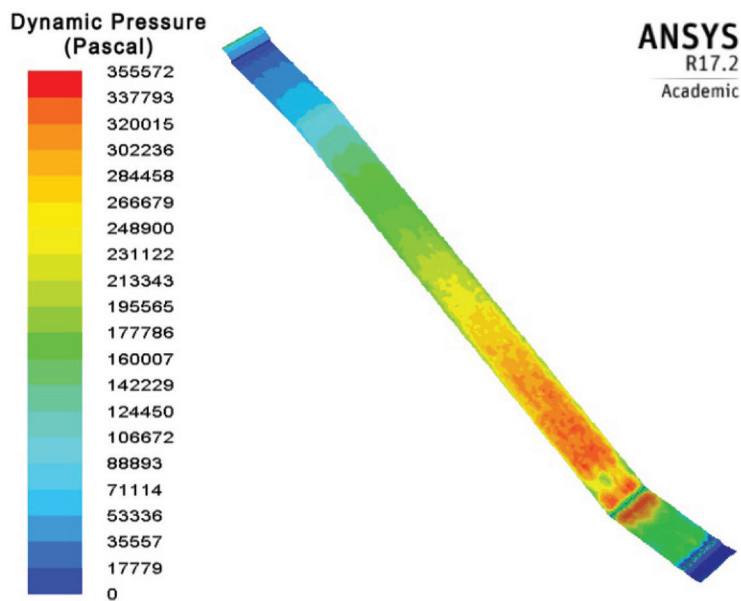

Figure 5. Dynamic distribution throughout the spillway body

The dynamic pressure distribution according to spillway length was given in Figure 5. Figure 5 shows that while pressure after the chute blocks increases, it decreases after the energy dissipating structures. Because velocity of water decrease in the chute blocks and energy dissipating structures, dynamic pressure also decrease on these locations. Additionally, great reduction on dynamic pressure took place in the energy dissipating structures.

Figure 6 shows location of chute blocks (1), energy dissipating structures (2), sill (3) and downstream (4), flows, water velocities and water depths belong to spillway. Table 1 also shows values determined by the ANSYS-Fluent simulations and calculated with pro-SHW for same locations.

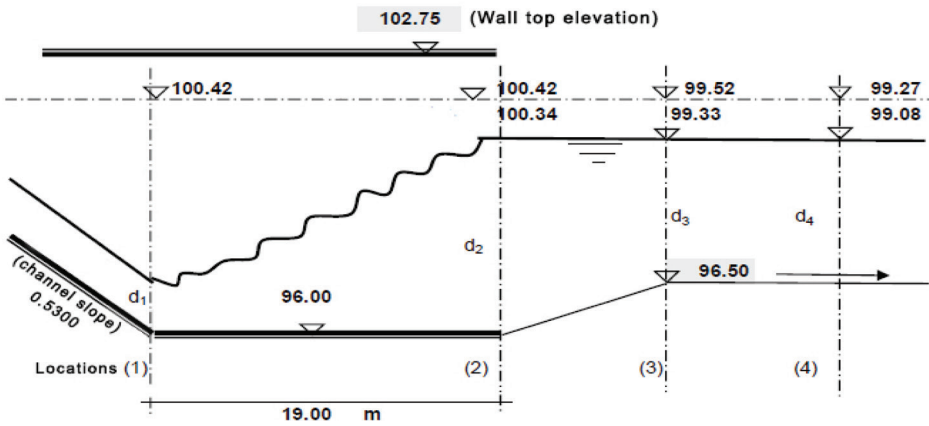

Figure 6. Location of energy dissipating structures in spillway.

Table 1. Comparison of the calculated and simulated velocity and depth values

		Location of chute blocks	Location of Energy dissipation structure	Location of sill	Location of down stream
		1	2	3	4
Velocity (m/s)	Calculated values	18.83	1.20	1.85	1.85
	Simulated values	19.06	1.24	1.92	1.93
	Error (%)	1.21	3.22	3.65	4.15
Depth (m)	Calculated values	0.28	4.34	2.83	2.83
	Simulated values	0.29	4.43	2.81	2.78
	Error (%)	4.47	2.00	0.71	1.78

As a results calculated values obtained from the pro-SHW were found very close each other with simulation values for same coordinates. When the error ratio is examined, it can be seen that the error ratio are very low. This means that compliance level between simulated and calculated values is very high. The less error ratio (values close to zero) shows the greater compliance level between simulated and calculated values.

CONCLUSION

Largely similarities has been found between calculated and simulated values at the end of the study. Mistakes that will be done are cause great economic loss and loss of life in the planning of water relief and storage structures that require high construction costs such as dams and small dam. Therefore, it is very important to know in advance the flow parameters such as pressure and velocity of water flows formed on the structure before such structures are made. Additionally, CFD method can be used instead of models prepared in laboratory environment by spending a lot of time.

ACKNOWLEDGEMENTS

The authors would like to thank to 13th Regional Directorate of General Directorate of State Hydraulic Works for their support.

REFERENCES

- Akuzum T. Ozturk F. (1996). Toprak Su Yapıları. Ankara Üniv. Ziraat Fakültesi Ders Kitabı. Yayın No:428, Ankara.
- Anonymous, (2012). Baraj Hidrolik Yapıların Tasarım Rehberi. T.C. Orman ve Su İşleri Bakanlığı, DSİ Genel Müdürlüğü, 1. Baraj Kongresi, No: 2, Ankara.
- Erkek C., Agiralioglu N. (2013). Su Kaynakları Mühendisliği. Beta Basım Dağıtım A.Ş. İstanbul.
- Ferziger J.H., Peric M. (2002). Computational Methods for Fluid Dynamics, Springer, 3rd Edition. ISBN 3-540-42074-6. pp 423, 2002.
- Wislicenus, G. F. (1964). Fluid Mechanics of Turbomachinery, Dover Publications Inc,

Corresponding author: Res. Asst. Ahmet Tezcan,
Prof. Kenan Büyüктаş,
Akdeniz University
Department of Farm Structures and Irrigation,
Antalya, Turkey.
e-mail: atezcan@akdeniz.edu.tr

İmran Sajid,
Suna Büyükkök
Akdeniz University
Institute of Science,
Antalya, Turkey.

Received: 02.04.2017

Accepted: 18.04.2017