

Paweł KOWALSKI*
Maciej CZYŻAK*

INTERNET SYSTEM FOR SUPPLY AND TEMPERATURE CONTROL IN SERVER ROOMS

The paper presents an internet system to manage 230 V electric devices in computer server rooms. The system is realized as the power strip connected to one of servers through the USB port. The system allows for the real-time temperature measurement and provides the maintenance-free operation. Moreover, it allows to turn on or off the connected devices using information from temperature sensors. Also it is possible to turn on or off every single socket disregarding temperature. The user communicates with the system through the web browser, and no dedicated software is required on the client side. The system has been installed and verified experimentally.

KEYWORDS: supply control, temperature control, server room

1. INTRODUCTION

The stable and steady climatic conditions in server rooms are one of the primary requirements with respect to IT infrastructure. This imposes specific requirement with respect to cooling systems. The increase of temperature shortens the life of electronic equipment and endangers the computer stability. In the extreme case it leads to difficulties or even the broken access to offered functionality. The reliability and longer life of electronic devices can be achieved by maintaining the temperature between 20°C and 25°C [1].

In air-cooled data centers the amount of heat generated by computers depends on their load, so the temperature and air flow in a server room can vary in a large range. Additionally, even the movement of a human may cause the temperature change [2]. The climatic conditions in the server room require the continuous control and the instant reaction in the case of abnormal conditions. The data center personnel is usually not able to immediately react when it is necessary. The longer delay in providing the appropriate cooling in the server room results in the temperature growth and more energy is required to cool down the room that raises maintenance costs. Hence there is a need to apply the system which has the possible long maintenance-free working cycle. There are many systems

* Gdansk University of Technology.

that give information about temperature and humidity. They also store data and show statistics over a certain period of time. But often these devices do not allow for remote observation and control of measured parameters. There are many systems of thermal management of air cooled data centers [3], but these systems are dedicated to big clusters, and it is really difficult to find a low-cost substitute for small server rooms. This paper presents a low-cost system which allows to use a conventional fan for the maintenance-free cooling. In Section 2 we make a review of commercial systems for the server room parameter control, and in Section 3 we present functional requirements and the design of the system, whereas in Section 4 the implementation is shown and discussed.

2. A REVIEW OF COMMERCIAL SYSTEMS

Big data centers usually dispose over security systems adapted to the shape and size of server rooms. Such systems provide temperature, humidity and access control, fire fighting and emergency power supply. They are very expensive, because they are dedicated to big clusters and should provide full security. The examples are the systems such as Colt [4] and Rittal [5].

Colt is a data center cooling system designer. The system by Colt is a climatic control system and consists of the ventilation infrastructure that uses fresh air and additionally water in the air-exchanger. In order to hold humidity at the constant level, the fresh air is mixed with the hot server exhaust air.

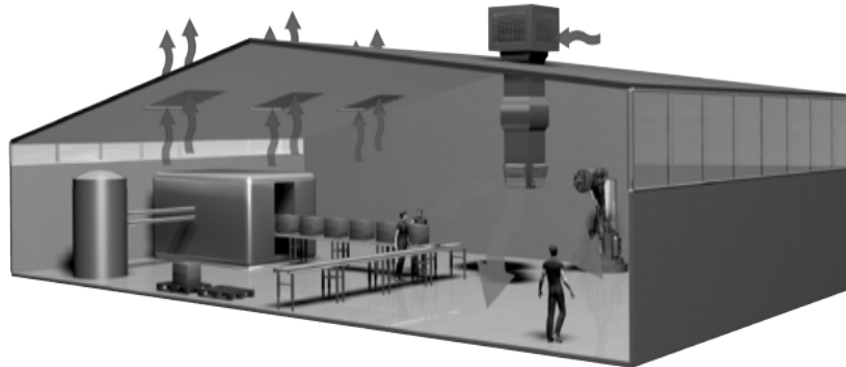

Fig. 1. Colt cooling system [4]

Rittal is the other climate control accessories producer. The product of Rittal termed “Digital enclosure internal temperature display and thermostat” [5], consists of three-digit 7-segment display, two relays to control the supply devices (max. constant load 230 V, 6 A) and a temperature sensor with the range from +5°C to +55°C. This device makes possible to set the temperature

thresholds when the supply is turn on or off in dependence on the temperature. The settings are changed by using the membrane keyboard at the front of the device. This device is shown on Fig. 2.



Fig. 2. Rittal digital enclosure internal temperature display and thermostat [5]

The third exemplary solution for the climatic control and maintenance-free cycle can be Datacenters in the Desert [1], where because of the desert conditions the reliable and efficient cooling is necessary. In this case there is an additional problem due to the high outside temperature and sand. The desert datacenter climatic control system uses the renewable energy sources and cold water to eliminate the need for air-conditioned rooms. This system has been designed for 300 MW data center [1].

2.1. Temperature control in closed spaces

The problem of temperature control in closed spaces is remarkably simplified due to the existence of sophisticated air conditioning systems. The most modern systems have the embedded temperature control. As an example may serve a system termed Climatronic [6] used in cars that allows to set and stabilize the required temperature and the air-conditioning turns on and off automatically. Climatronic control panel shown on Fig. 3 allows setting the required temperature. However, it does not allow for the remote control of the temperature via internet. Hence the use of the modern air conditioning is only a partial solution.



Fig. 3. Climatronic control panel [6]

The most complete solution could be the use of an air conditioning system with the additional measurement equipment which can be allocated in more than one different measuring point in the given space. This would provide a solution that allows to receive a more precise information about the close space as the server room. Additionally, these devices can be used to generate statistical data about climatic conditions in server rooms that is very important when calculating the maintenance costs of objects of this type.

2.2. Temperature sensors

The temperature can be measured using various sensors. They can be divided into two main groups with respect to the signal output: analogue and digital. In t analog temperature sensors, the measured value may be represented by resistance or voltage. In such a solution the temperature is available continuously. The sensor usually does not need any supply and the resolution depends on used the given measuring device. The second group are digital thermometers that provide the measured temperature through interfaces like I²C [7] or 1Wire [8]. These devices have the predetermined resolution. Their advantage is the possibility to connect few thermometers to one bus. So to connect 1 or 5 thermometers, the same number of microcontroller pins is needed.

In the designed and implemented device the digital temperature sensor LM75A [9] was used. This sensor measures temperature in the range from -55°C to 125°C. The delay of this thermometer was tested by cooling it to -24°C and measuring the time to stabilize the temperature at 22°C in the room. Also the thermometer was tested by heating it to about 100°C and putting inside the room with the temperature of 22°C in order to measure the time of the temperature stabilization.

The delay of the temperature measurement from -24°C to 22°C was about 180 s, whereas from 100°C to 22°C 240 s. It was observed, the process of attaining the proper temperature in is very slow its final phase (last few degrees). This behavior manifests itself when the temperature is growing or falling down.

It took about 60 s for the temperature growth from 20°C to 22°C, but it took 90 s from 24°C to 22°C. It can be assumed that the thermometer returns the temperature delayed by no more than 240 s.

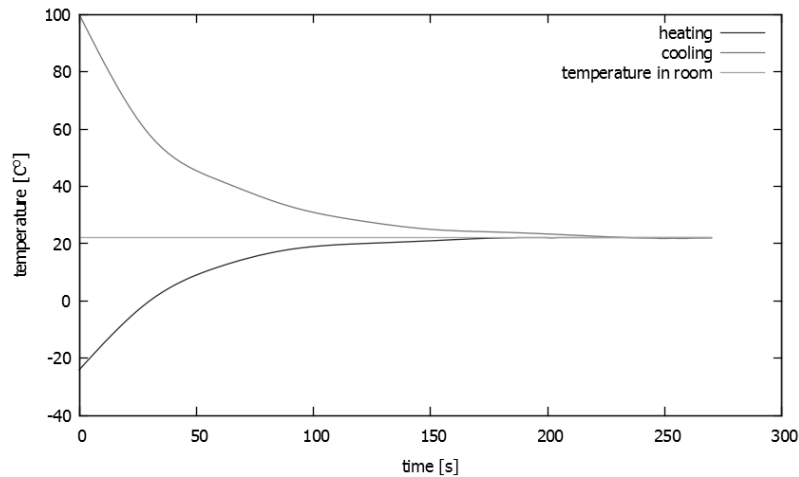

Fig. 4. Delay in temperature stabilization

3. DESIGN OF TEMPERATURE MEASUREMENT SYSTEM

The system requirements are as follows:

- small device looking like a standard power strip,
- supply from the USB port,
- possibility to remotely turn on and off any socket,
- remote real-time temperature viewing,
- possibility to automatically turn on and off the defined socket in dependence upon the temperature,
- device should not be connected directly to the local area network and should not work as an independent network device,
- remote control should be as simple as possible. The system should have unauthorized access protection.
- 5 V and 230 V supplies should be separated.

4. THE SOLUTION FOR INTERNET SYSTEM FOR SUPPLY AND TEMPERATURE CONTROL

The system was designed to control temperature in low-cost server rooms by turning on and off the fan connected to one supplying socket. The elaborated power strip allows for the remote real-time temperature measurement, setting

temperature restrictions and also turning on any socket with the omission the temperature restrictions. The device is powered by the USB port and does not need any communication with PC to work correctly. The device is small and the printed board is located inside the standard power strip body. The strip can control any device of power up to 500 W.

The system was designed for home, temporary server rooms which are often based on old computers. In such conditions, the realization of a complex system or even installing air conditioning may be too costly. However, safety and acceptable climatic conditions should be provided.

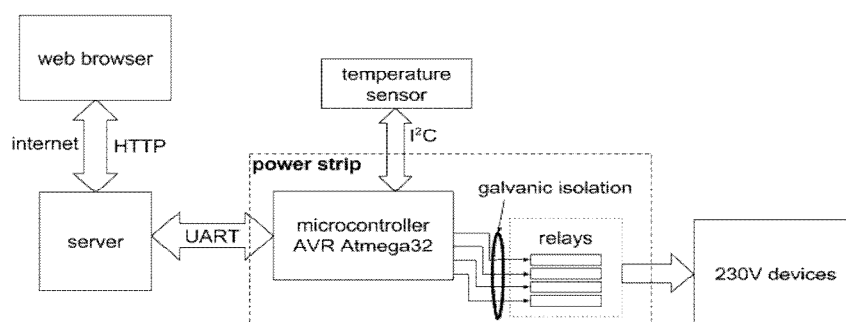

Fig. 5. General structure of the system

In Fig. 5 the general structure of the system is depicted. The server here is the computer that supervises the elaborated system. This computer provides the interface for the user over the Internet using the HTTP protocol and communicates with the user via a standard web browser. The server receives requests from the user by POST and GET method, then reads and sends data to the power strip, and next answers to the user by sending the appropriate HTML page. The communication between the server and the power strip is realized through the UART port. Physically the USB port is utilized by using the USB - to - UART converter FT232RL [10]. This converter is transparent to the system. The applications that run on the server and microcontroller communicate through the UART without caring about physical connections. The power strip block contains the components mounted in the power strip body. It consists of the microcontroller and relays isolated by transoptors. The microcontroller communicates with the temperature sensor over the I²C. The relays are controlled by the microcontroller and in consequence 230 V devices are driven through the PORT D of the Atmega microcontroller.

The device can receive two types of commands: *port* and *temp* commands with two arguments or without any arguments. The commands can have the following forms *port*, *temp*, *port x y* or *temp x y*, where *x* is a port number and *y* indicates the types of information contained in the command:

- *temp* is the temperature in °C,
- *port* can be 0 (carry out turn off), or 1 (carry out turn on).

Sending *temp* or *port* commands without arguments results in getting information about the actual temperature or the state of sockets.

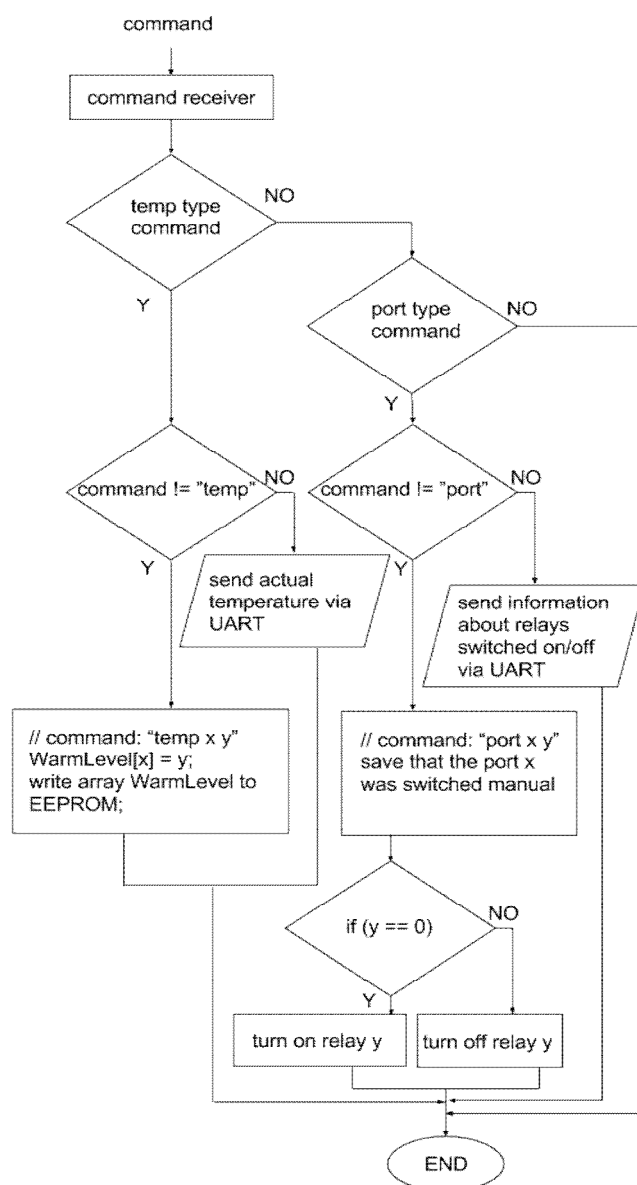

Fig. 6. Flowchart of command processing



Fig. 7. Power strip

The power strip is shown in Fig. 7 and in Fig. 8 its electric schema is demonstrated. In the upper left corner of Fig. 8 the USB \leftrightarrow UART converter of FT232RL type is shown. This device is supplied with 5 V from the USB port. The microcontroller Atmega32 (μ C) is supplied with 5 V from the USB port and is driven with 16 MHz crystal oscillator. The relays (K1, K2, K3, K4) are connected using the transoptor TLP281-4 (OK1A/B/C/D). Switching on the relay K1 results in 230 V on X1-4 output connector, also there are four output connectors: X1-1, X1-2, X1-3, X1-4, and one input X1-5. The supply from the X1-5 connector is distributed to all relays.

4.1. Software

The elaborated software consists of two parts. The first part, which was written in C using AVR Studio, is installed on Atmega32 controller. The www server that collaborates with the client over the Internet and the controller was written in Python. The prior installations of Python 3 [11], Django [12], Pillow [13] and pyserial [14] are required. Django is a web framework for Python, Pillow is a library which allows for easy processing of images when using Python and pyserial provides the API for the UART communications.

Django and Python were chosen, because this set allows to run the code on Linux and Windows platforms without any changes.

When the application on the server starts, the web server is started. The Django web server operates over the different port than ports used usually by

other www servers and does not influence other programs running on the computer. This approach reduces the server setup time to the minimum niveau.

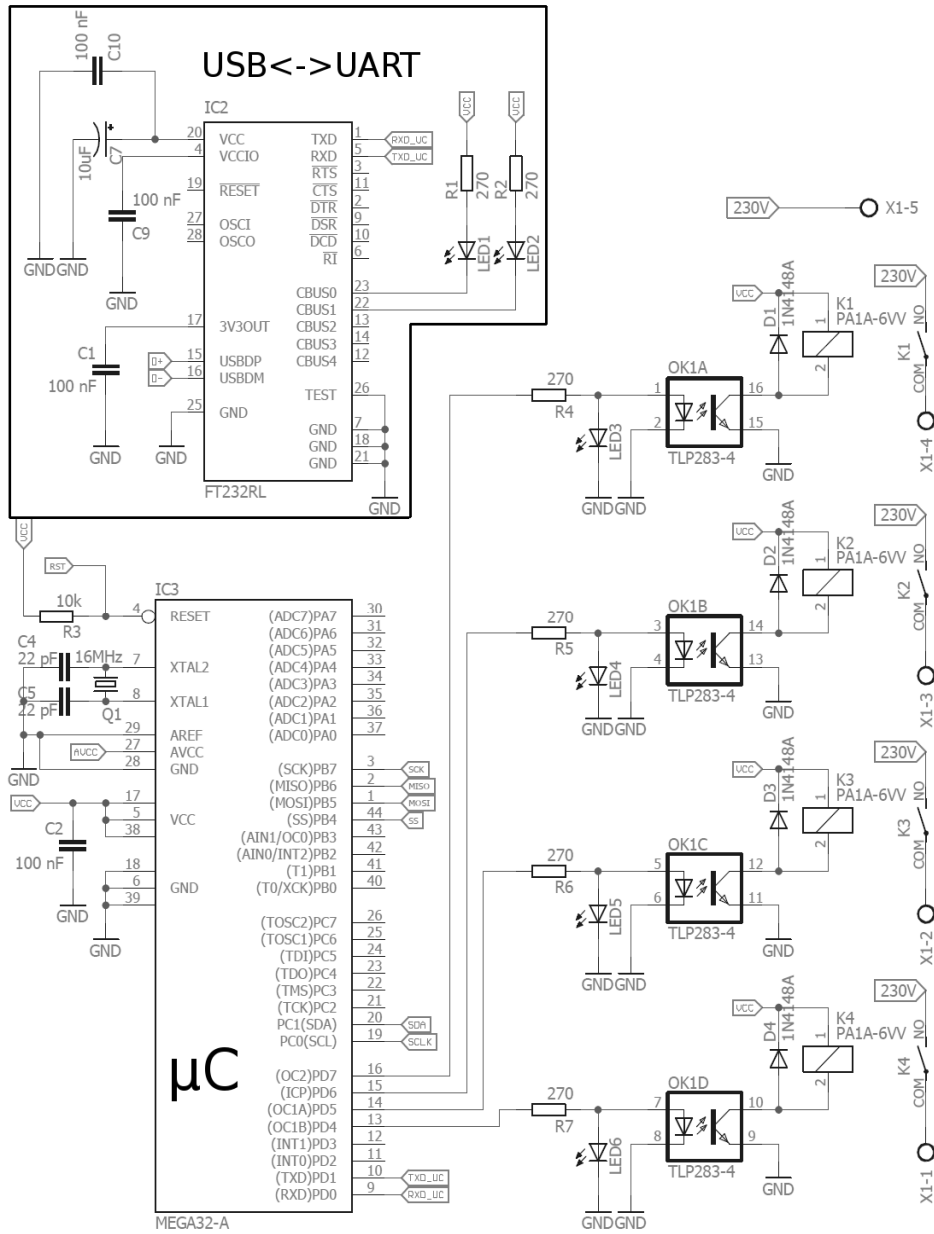

Fig. 8. Electric scheme of the system

It is needed only to choose which port the web server should use and to which COM port the power strip is connected. This approach allows also to control the device without any specific software required on the client machine, which can be a computer, a mobile phone or other device with a web browser.



Fig. 9. Control panel information displayed on smartphone in the mobile web browser (Opera Mobile)

The server generates the window that contains the control panel.

In Figure 9, the control panel is depicted. This website is protected from the unauthorized access. Without login we can see all parameters in the real-time, but we can not change them. After login, the control panel starts to respond.

The temperature setting for each individual socket can be programmed. The programmed temperature value denotes that if this temperature inside the server room is exceeded, then the fan, controlled by the given socket, will be turned on. It will be turned off when the temperature falls by two degrees. It is also possible to turn on and off any socket with regarding temperature restrictions.

5. CONCLUSIONS

We have presented a system that allows for the remote control of temperature in small server rooms. The control can be performed over the Internet using any device with a web browser. It is possible to check the temperature and set it properly. Once the temperature is set, the device works automatically switching on or off the 230 V supply of the cooling device when needed. Moreover, it is possible to switch on or off any socket without regarding the temperature.

The presented system is a suitable solution for small and low-cost server rooms. The main advantage, as compared to other systems, is its cost. Additionally, the system is a multiplatform, and can be run on any operating system with Python installed. The system was tested on Windows and Linux, with the browsers Internet Explorer version 11, Opera version 26, Mozilla version 34 and Google Chrome version 40.0.2214.

REFERENCES

- [1] Vijaykumar N., Datacenters in the Desert, *Technol. Soc. Mag. IEEE*, vol. 30, no. 2, pp. 31–38, 2011.
- [2] Ma S., Zhu M., Wang L., Shu L., Li S., and Huang S., A Remote Monitoring System of IDC Room Based on ZigBee Wireless Sensor Networks, Eighth IEEE International Conference, Dependable, Autonomic and Secure Computing, 2009. on, 2009, pp. 782–787.
- [3] Bash C. E., Patel C. D., and Sharma R. K., Dynamic thermal management of air cooled data centers, The Tenth Intersociety Conference Thermal and Thermomechanical Phenomena in Electronics Systems, 2006, p. 8 pp.–452.
- [4] Colt, People work better in Colt conditions Colt Climate Control products and services, 2016.
- [5] Rittal, Rittal - The System, Catalogue 2014/2015, 2014.
- [6] Volkswagen International Homepage, Climatronic, [Online]. Available: <http://en.volkswagen.com/en/innovation-and-technology/technical-glossary/climatronic.html>. [Accessed: 11-Jan-2016].
- [7] NXP Semiconductors, UM10204, I2C-bus specification and user manual, 2014.
- [8] Texas Instruments, 1-Wire Enumeration, Application Report, 2013.
- [9] NPX, LM75A Datasheet, 2007.
- [10] FTDI Chip, FT232R USB UART IC Datasheet, 2015.
- [11] Python Software Foundation, Python 3.5.1 Documentation, 2016.
- [12] Django Software Foundation, Django Documentation, 2016.
- [13] Alex Clark, Pillow (PIL Fork) Documentation, Release 2.6.1, 2015.
- [14] Chris Liechti, pySerial Documentation, Release 3.0.1, 2016.
- [15] Amoo A. L., Guda H. A., Sambo H. A., Soh T. L. G., Design and implementation of a room temperature control system: Microcontroller-based, Student Conference on Research and Development (SCORED) in 2014 IEEE, 2014, pp. 1–6.
- [16] Chen C., Sun L., Shao Y., Hu Z., Shi Q., IEMS: An Intelligent Environment Monitoring System of Server Room, 2012 Fifth International Conference, Intelligent Computation Technology and Automation (ICICTA), 2012, pp. 189–192.
- [17] Libo D. and Xuehui W., Design of a web-based temperature and humidity monitoring system, 2nd International Conference, Artificial Intelligence, Management Science and Electronic Commerce (AIMSEC), 2011, pp. 2028–2030.

(Received: 01. 02. 2016, revised: 3. 03. 2016)