

Zio Enrico*Ecole Centrale Paris- Supelec, Paris, France, Politecnico di Milano, Milano, Italy***Piccinelli Roberta****Delfanti Maurizio****Olivieri Valeria****Pozzi Mauro***Politecnico di Milano, Milano, Italy*

Performance analysis of a power transmission system under uncertain load conditions and network configurations

Keywords

vulnerability, electric power transmission network, load flow, power flow betweenness centrality, uncertainty

Abstract

In this paper, the load flow problem in a power transmission network is studied in presence of load and power generation uncertainties and transmission lines failures. Network performance indicators are computed and the importance of the different components is evaluated by a power flow betweenness centrality measure.

1. Introduction

Power flow studies, often referred to as load flow (LF) analyses, are used for planning, operation, economic scheduling and exchange of power between utilities; they are also required for contingency studies.

The traditional, deterministic load flow analysis finds nodal voltages and line flows under a specific operating condition. On the other hand, the information sustaining load flow calculations are stochastic in nature (e.g. bus powers and configurations): hence, the input quantities for the calculations should be treated as random variables. To solve the load flow problem probabilistically, the great majority of methods [2],[4],[12] only account for load and power generation data uncertainties, whereas the network configuration is considered fixed. In [9], methods are presented for obtaining a probabilistic load flow solution when network outages are modelled as random variables. The effects of the configuration uncertainties have rarely been considered in detail, in spite of the fact that any change in the network of links of the power transmission system will alter the configuration and,

consequently, the set of functions relating inputs and outputs.

In this paper, power transmission system configuration changes due to line failures are accounted for by Monte Carlo sampling and the network performance characteristics are determined. A power flow betweenness centrality measure [9] is used to characterize the importance of the different components in the system.

The paper is organized as follows. In Section 2, a short description of the load flow calculation model is provided. In Section 3, the topological concept of betweenness centrality measure is recalled. The presented modelling framework is applied to the IEEE 14 BUS network system [13] and the results obtained are discussed in Section 4. Conclusions are drawn in Section 5.

2. Load Flow model (LF) [7]

From the physical point of view, the interconnections of the different elements of a power transmission system provide the basis for the development of an overall load flow model for the simulation of the system performance under a wide variety of

projected operating conditions. Successful power system operation under normal conditions requires the following:

- generation supplies the demand (load) plus losses;
- bus voltage magnitudes remain close to their rated values;
- generators operate within specified power limits;
- transmission lines and transformers are not overloaded.

The power flow problem (also known as the load flow problem) addressed by the computational model states that: “for a given power network, with known power loads and some set of specifications or restrictions on power generations and voltages, a solution is provided for any unknown bus voltages and for the power flow in the network components” [7].

The power network description may be given in the form of a system map and accompanying data tables specifying the components characteristics. These include the failure probabilities of components and transmission lines and the values of generating units, loads and line parameters.

Three basic sources of variation can be identified: the first is the variation in the actual parameters defining loads and power generating units; the second is the variation of lines capacity, transformers or other components parameters; the third source of variation is associated with the availability or unavailability of components such as transmission lines, transformers, etc, as they are subject to outages due to faults and maintenance.

The steps of the Direct Current (DC) power flow computation here set up can be summarized as follows:

1. Sample the fault configuration of the network on the basis of the failure probabilities of each element (node or arc) of the system.
2. Sample the production from the sources, the demand at the targets and the capacity of the arcs.
3. Develop the mathematical model describing the power flow in the network, under the sampled conditions.
4. Solve for the voltage profile of the network.
5. Solve for the power flows in the network.
6. Check for constraint violations: the capacities of the transmission lines are checked; if their values are larger than the maximum capacities of the node to which they are connected, overloads are recorded;

if the load exceeds the generation supplies, a blackout is recorded.

3. Power flow betweenness centrality measure

Determining the critical elements of large-scale network infrastructures is an important issue for their reliability and protection. From a topological point of view, a number of centrality indices, that take into account the different ways in which a node interacts and communicates with the rest of the network, have been introduced as measures of the importance of the nodes in a network [15]. These indices have proved of value in the analysis and understanding of the role played by the elements in the network.

A classical topological centrality measure is the betweenness centrality [9]. This measure is based on the idea that a node is central if it lies between many other nodes, in the sense that it is traversed by many of the shortest paths connecting pairs of nodes. The topological betweenness centrality C_i^B of a given node i in a network $G(N, K)$, where N is the number of nodes and K is the number of links connecting them, is quantitatively defined as:

$$C_i^B = \frac{1}{(N-1)(N-2)} \sum_{j,k \in G, j \neq k \neq i} \frac{n_{jk}(i)}{n_{jk}} \quad (1)$$

where n_{jk} is the number of topological shortest paths between nodes j and k , and $n_{jk}(i)$ is the number of topological shortest paths between nodes j and k which contain node i . C_i^B assumes values between 0 and 1 and reaches its maximum when node i falls on all geodesics (paths of minimal length between pairs of nodes).

From the definition, betweenness centrality can be regarded as a measure of the influence a node has on the spread of the flow through the network, of the extent to which a node has control over the flow between other nodes. In a network in which flow is entirely or at least mostly distributed along geodesic paths, the betweenness of a vertex measures how much flow will pass through that particular vertex.

In most networks, as in power transmission networks, however, flow does not occur only along geodesic paths; in some cases, flow may not follow the ideal route to get from one place to another, and “wander around” in a random-like fashion or as directed by the system operative rules and constraints. In most cases, a realistic betweenness measure should include non-geodesic paths in addition to geodesic ones [3].

To account for this issue, a betweenness centrality measure based on the concept of network flow has been suggested [6]. What is relevant here is not just the direct flow between connected nodes, but the

overall flow between pairs of nodes along all the paths that connect them: if a node i is chosen as an information source, or transmitter, and another node j as an information sink, or receiver, information from i may reach j along an edge linking i directly to j or along any and all indirect paths that begin at i , pass through one or more intermediate nodes and end at j . Thus, the flow between two nodes is a global phenomenon: it depends, not just on the capacity of the channel linking two nodes directly, but on the capacities of all the channels on all the paths – both direct and indirect – that connect the two. The LF model calculation considers the load that must be dispatched to the targets and, consequently, calculates the flow through all the transmission lines of the network in order to serve them [8]. To model this, a new betweenness centrality measure has been introduced [10]. Let PF_i^{st} be the power flow flowing from s to t , through node i ; quantitatively the power flow betweenness centrality measure is defined as:

$$PFC_i^B = \frac{\sum_{s=1, s \neq i}^N \sum_{t=1, t \neq i}^N PF_i^{st}}{\frac{1}{2}N(N-1)} \quad (2)$$

This measure reasonably describes the fact that power will flow along all paths from source to target, and nodes that lie on no path from source to target get a betweenness of zero

In this paper, power flow betweenness centrality measures are evaluated considering the physical characteristics of the transmission network in terms of length, capacity and failure probability of each transmission line, and types of nodes.

4. Application

The artificial transmission network system IEEE 14 BUS [13] is taken as reference case study. The network represents a portion of the American Electric Power System and consists of 14 bus locations connected by 20 lines and transformers, as shown in *Figure 1*. The transmission lines operate at two different voltage levels, 132 kV and 230 kV. The system working at 230 kV is represented in the upper half of *Figure 1*, with 230/132 kV tie stations at Buses 4, 5 and 7. The system is also provided with voltage corrective devices in correspondence of Buses 3, 6 and 8 (synchronous condensers). Buses 1 and 2 are the generating units.

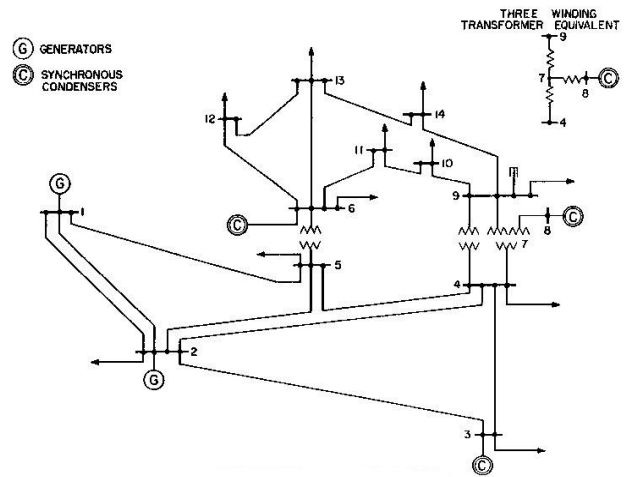

Figure 1. Transmission network IEEE 14 BUS[13].

To carry out the analysis, each network component is transposed into a node or edge of the representative topological network, as it is shown in *Figure 2*. Three different physical types of nodes are considered: source nodes (where the electricity is fed into the network), load nodes (where customers are connected) and transfer or transmission nodes (without customers or source).

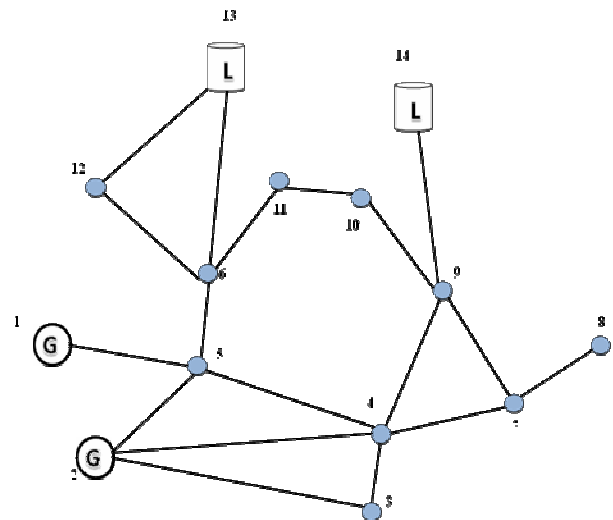

Figure 2. The IEEE 14 BUS transmission network's graph representation [11]. The large white circles labeled with **G** represent the generator nodes, the small grey circle nodes represent the transmission nodes and the white cylinders labeled with **L** represent the load nodes.

Table 1 reports the failure rate values of the components of the transmission network, as inferred from literature data [1].

Table 1. Failure data of the arcs of the IEEE 14 BUS transmission network.

| From BUS | To BUS | Failure rate/yr/100km | Failure rate/yr |
|----------|--------|-----------------------|-----------------|
| 1 | 2 | 1.0858 | |
| 1 | 5 | 1.0858 | |
| 2 | 3 | 1.0858 | |
| 2 | 4 | 1.0858 | |
| 2 | 5 | 1.0858 | |
| 3 | 4 | 1.0858 | |
| 4 | 5 | 1.0858 | |
| 4 | 7 | | 0.01045 |
| 4 | 9 | | 0.01045 |
| 5 | 6 | | 0.01045 |
| 6 | 11 | 0.5429 | |
| 6 | 12 | 0.5429 | |
| 6 | 13 | 0.5429 | |
| 7 | 8 | | 0.01045 |
| 7 | 9 | | 0.01045 |
| 9 | 10 | 0.5429 | |
| 9 | 14 | 0.5429 | |
| 10 | 11 | 0.5429 | |
| 12 | 13 | 0.5429 | |
| 13 | 14 | 0.5429 | |

The failure probability of edge ij is defined as:

$$q_{ij} = 1 - e^{-\lambda_{ij}T} \quad (3)$$

where λ_{ij} is the constant failure rate per unit time of the edge ij linking nodes i and j (column 4 in Table 1) and T is the reference time for the analysis, here chosen equal to 1 year.

Because the failure rate data are usually given as functions of the lengths of the transmission lines (column 3 in Table 1), in order to compute the failure probability (3), two transmission line lengths of 48 km and 50 km have been considered.

The lengths of the transmission lines in the IEEE 14 BUS are listed in Table 2. Lines containing transformers are considered to be zero-length lines. In this case, the lower half of the network has the largest failure probability.

Source generation is sampled from a normal distribution with a mean value of 30 and a variance of 100, in arbitrary units (a.u.). The values of the capacities of the network links are assumed all distributed according to a normal distribution of mean value 100 a.u. and a standard deviation of 10 a.u.

Table 2. Length and failure probabilities of the arcs.

| From BUS i | To BUS j | Length(km) l_{ij} | Failure probability q_{ij} |
|------------|----------|---------------------|------------------------------|
| 1 | 2 | 48 | 0.4079 |
| 1 | 5 | 48 | 0.4079 |
| 2 | 3 | 48 | 0.4079 |
| 2 | 4 | 48 | 0.4079 |
| 2 | 5 | 48 | 0.4079 |
| 3 | 4 | 48 | 0.4079 |
| 4 | 5 | 48 | 0.4079 |
| 4 | 7 | - | 0.0104 |
| 4 | 9 | - | 0.0104 |
| 5 | 6 | - | 0.0104 |
| 6 | 11 | 50 | 0.2372 |
| 6 | 12 | 50 | 0.2372 |
| 6 | 13 | 50 | 0.2372 |
| 7 | 8 | - | 0.0104 |
| 7 | 9 | - | 0.0104 |
| 9 | 10 | 50 | 0.2372 |
| 9 | 14 | 50 | 0.2372 |
| 10 | 11 | 50 | 0.2372 |
| 12 | 13 | 50 | 0.2372 |
| 13 | 14 | 50 | 0.2372 |

The network performance characteristics computed on the basis of the LF model are reported in Table 3, where:

- blackouts and overloads are evaluated considering the average value of the flow that does not reach the targets or that exceeds the capacities of the transmission lines, respectively;
- the network demanded load is the average sum of the power generated from all the sources s_i , $i=1, 2, \dots, N_S$:

$$NDL = \sum_{i=1}^{N_S} s_i \quad (4)$$

- the network received load is the average sum of the flow reaching the targets t_i , $i=1, 2, \dots, N_T$:

$$NRL = \sum_{i=1}^{N_T} t_i \quad (5)$$

- the network lost load is obtained as the difference between demanded and received loads:

$$NLL = NDL - NRL \quad (6)$$

- the network service efficiency is obtained as the ratio between received and demanded loads:

$$NSE = \frac{NRL}{NDL} \quad (7)$$

Table 3. Network performance indicators.

| Quantity | LF |
|----------------------------|-------|
| Blackout(%) | 0.04 |
| Overload(%) | 0.76 |
| Network service efficiency | 0.2 |
| Network demanded load | 62.71 |
| Network received load | 12.35 |
| Network lost load(a.u.) | 49.82 |

The system has a low network service efficiency: this is due mostly to overloads.

In order to understand the behaviour of the flow in the system, the power flow betweenness centrality values of the nodes are reported in Table 4, ranked in order of descending values. Nodes 1 and 2 have the highest values: they are source nodes. Nodes 8 and 11 are zero-betweenness centrality nodes. The arcs that connect these nodes to the network undergo failure most frequently. In the lower part of the network, betweenness centrality values are higher than in the upper part. Moreover, node 14 does not receive any flow.

Table 4. Betweenness centrality measure.

| Rank | Node Number | Power Flow Betweenness Centrality |
|------|-------------|-----------------------------------|
| 1 | 2 | 0.4863 |
| 2 | 1 | 0.4532 |
| 3 | 6 | 0.4255 |
| 4 | 5 | 0.4023 |
| 5 | 4 | 0.3739 |
| 6 | 9 | 0.3068 |
| 7 | 12 | 0.1455 |
| 8 | 13 | 0.1357 |
| 9 | 7 | 0.0927 |
| 10 | 3 | 0.0457 |
| 11 | 10 | 0.0297 |
| 12 | 14 | 0.0000 |
| 13 | 11 | 0.0000 |
| 14 | 8 | 0.0000 |

Nodes 4, 5 and 6 connect the lower half of the network with the upper half: a reduced flow passing through them prevent the flow, coming from the sources (lower half), from joining the targets nodes (upper half) especially considering that nodes 10 and

11 show nearly no betweenness centrality (Figure 3), that is there is nearly no flow passing from the upper left part (nodes 6, 9 and 13) to the right part (nodes 9 and 14) of the network (Figure 2).

5. Conclusions

A flow analysis with load, generation and configuration uncertainties has been applied to a power transmission network of literature. Uncertainty of configuration due to lines failures has been included into the power flow calculation, by Monte Carlo sampling.

Two types of output are of interest in the analysis: network performance indicators and the power flow betweenness centrality of its elements. The performance indicators give an overview on the service efficiency of the network while the power flow betweenness identifies the importance of the role played by the different components determining the flow through the network.

Acknowledgements

This work has been partially funded by the Foundation pour une Culture de Sécurité Industrielle of Toulouse, France, under the research contract AO2006-01.

References

- [1] Billington, R. & Li, W. (1994). *Reliability Assessment of electric power system using Monte Carlo Methods*. 19-20.
- [2] Borkowska, B. (1974). Probabilistic Load flow. *IEEE Trans.*, PAS-93, 752-759.
- [3] Borgatti, S.P. (2005). Centrality and Network Flow. *Social Networks* 27, 55 -71.
- [4] Dopazo, J.F., Klitin, O.A. & Sasson, A.M. (1975). Stochastic load flow method. *IEEE Trans.* PAS-94, 1551-1556.
- [5] Freeman, L.C. (1979). Centrality in Social Networks: Conceptual Clarification. *Social Networks*, 1, 215 – 239.
- [6] Freeman, L.C., et al. (1991). Centrality in valued graph: a measure of betweenness based on network flow. *Social Networks* 13, 141-154.
- [7] Grisby, L.L. (2007). *Power Systems*, CRC Press.
- [8] IEEE Transaction on Power systems. (1999). Vol.14, No. 3, August 1999.
- [9] Leite da Silva, A.M. et. al. (1985). Probabilistic load flow considering network outages. *IEE Proceedings*, Vol 132, No.3.
- [10] Newman, M.E. (2003). A measure of betweenness centrality based on random walks. Preprint cond-mat/0309045.

- [11] Pajek, Program for large network analysis:
<http://vlado.fmf.uni-lj.si/pub/network/pajek/>.
- [12] Sobjerajski, M. (1978). A method of stochastic load flow calculation. *Archiv für Elektrotechnik* 37-40.
- [13] The IEEE 14 BUS data can be found on:
<http://www.ee.washington.edu/research/pstca/>
- [14] The MATPOWER home page can be found at:
<http://www.pserc.cornell.edu/matpower/>.
- [15] Zio, E. (2007). From Complexity Science to Reliability Efficiency: A new Way of Looking at Complex Network Systems and Critical Infrastructures. *Int. J. Critical infrastructures*, Vol. 3, Nos. ¾, pp.488 – 508.