

# Historical Perspectives of Development of Antique Analog Telephone Systems

Vinayak L. Patil

Trinity College of Engineering and Research, University of Pune, Pune, India

**Abstract**—Long distance voice communication has been always of great interest to human beings. His untiring efforts and intuition from many years together was responsible for making it to happen to a such advanced stage today. This paper describes the development time line of antique telephone systems, which starts from the year 1854 and begins with the very early effort of Antonio Meucci and Alexander Graham Bell and ends up to the telephone systems just before digitization of entire telecommunication systems. The progress of development of entire antique telephone systems is highlighted in this paper. The coverage is limited to only analog voice communication in a narrow band related to human voice.

**Keywords**—antique telephones, common battery systems, cross-bar switches, PSTN, voice band communication, voice communication, strowger switches.

## 1. Initial Claims and Inventions

Since centuries, telecommunications have been of great interest to the human beings. One of the dignified personality in the field of telecommunication was Antonio Meucci [1]–[7] (born in 1808) who worked relentlessly for communication to distant person throughout his life and invented telephone in 1849. Although he was nowhere near to claim his invention, he will be remembered for his noble work he did at that time.

In 1854, Meucci migrated to Clifton area of Staten Island near New York [8]. He set up communications link in his Staten Island home that connected the basement with the first floor, and later, when his wife began to suffer from crippling arthritis, he created a permanent link between his lab and his wife's second floor bedroom. Meanwhile, he perfected his instrument to be able to demonstrate for financial backup. In 1860 he demonstrated it publicly, which appeared in New York's Italian language newspaper. His life's saving was exhausted in perusing his invention. Meucci was unable to raise sufficient funds to pay his way through the patent application process. However, he was able file the caveat in 1871 and renewed in 1872 and 1873 but could not renew it after that. The constructional details of Meucci's telephone instrument are shown in Fig. 1. Many contestants were in fray for the invention related to telephones. In 1854, Bourseul [9] publishes description regarding make and break telephone transmitter and receiver to put forward an idea of how to transmit speech electri-

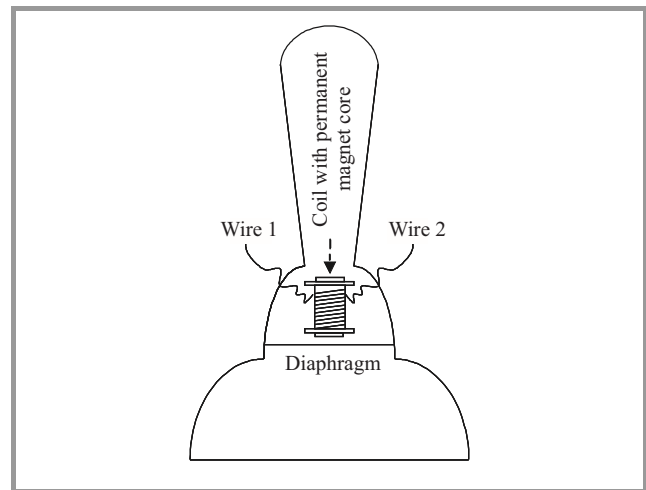

Fig. 1. The details of Meucci's telephone.

cally. Due to this idea, many of the scientific community consider him as one of the inventors of telephone [10]. Bourseul used term “make and break” telephone in his work. In 1850, Philip Reis [11]–[13] began work on telephone. Working towards the Bourseul's idea, he was successful in his attempts in 1860. His work appeared in New York Times editorial on March 22, 1876. His instrument consisted of a horn to collect the sound that was allows to strike the diaphragm, which was in loose contact with point contact. The loose contact represented a variable resistance responsible for modulating signaling current. While receiver was consisted of needle that was made to vibrate by signaling current, while these vibrations were acoustically amplified by mounting vibrating needle on sound box

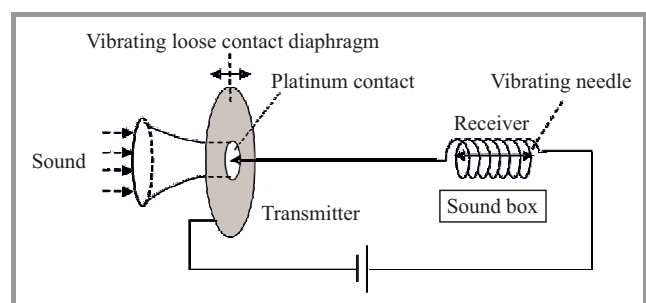

Fig. 2. Reis's principle of sound transmission.

itself. The adjustments related to this needle were critical for device operation. However, with these arrangements, he was able to transmit tones and some vowels the Reis instrument shown in Fig. 2 was better suitable for music than human voice. The era of work of Reis was nearly coinciding with an era that of Meucci.

**1.1. Bells’s First Telephone Design**

On June 2, 1875 Bell along with his assistant Thomas A. Watson working in Williams machine shop in Boston discovered that sound notes can be electrically transited through wires from one room to other using electromagnet. The Bell’s first telephone also called as Bell’s Gallows Telephone [12], [14]–[17] consists of parchment membrane, reed relay armature, core and a coil (Fig. 3a). The voice/sound is responsible making membrane to vibrate and the movements are then picked up by the reed relay armature. As this reed relay armature is moved through the magnetic field of relays coils, it induces fluctuating electric current in the coil. The variation in the current is then transmitted to receiving relay for further reproduction. This first telephone design never worked, possibly because the coil did not use permanent magnet to produce sufficient current and possibly the membrane could have made up of iron disk instead of parchment membrane. This gallows type telephone is shown in Fig. 3b.

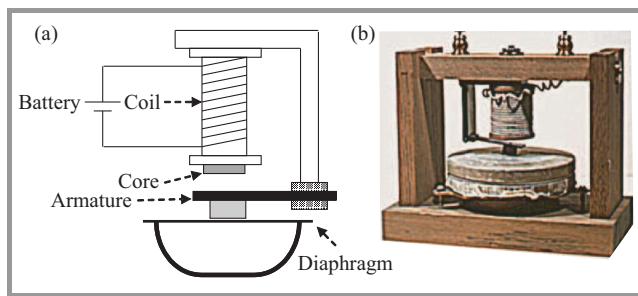

Fig. 3. Bell’s first gallows telephone.

As per the records of Bell’s note book pages, his invention related to telephone was ready on January 20, 1876 and on February 14, 1876, he filed a patent application regarding “Improvement in telegraphy” [19], [20], while just few hours later the caveat entitled “Transmitting vocal sounds telegraphically” was filed by attorney of Elisha Gray [21], [22] professor at Oberlin College. Transmitting end of Elisha’s instrument (Tone telegraph) operated on similar way as that of Reis. It used vibrating steel rod that interrupted a current in the circuit. While at receiving end, it used an electromagnet with steel reed near the magnetic pole (Fig. 4).

On March 7, 1876, as per United States patent law and its clause, issued a patent to Alexander Graham Bell (No. 174465) declaring him, the legal inventor of telephone. It was not also free from controversies those still exists till today. The controversy was triggered by application filed on the same day by Gray [19].

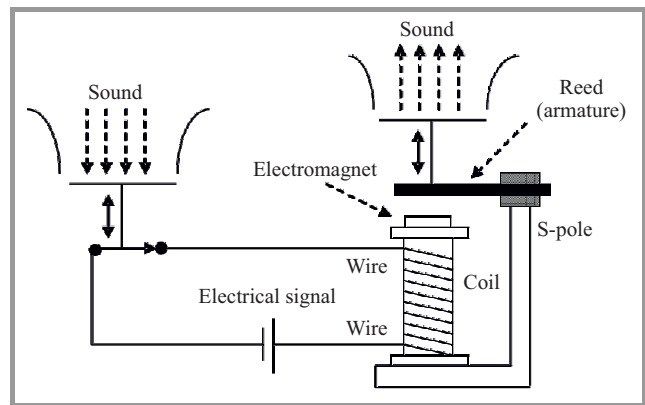

Fig. 4. Elisha Gray’s work on sound transmission.

The inventions made by various researchers were shadowed by legal status awarded by United States patent office to Bell and all the issues related to “Invention of telephone” were then buried for silence.

**2. Producing Electrical Voice Signals**

Earlier mechanisms were based on coils constructed using permanent magnets. One pole of magnet is brought near to other pole through armature and is nearly in contact with each other. Sound vibrations sensed using a diaphragm are transmitted to armature changing the gap between two poles of permanent magnet. These changes of flux are then responsible for change of current in coil. This mechanism of sensing is shown in Fig. 5.

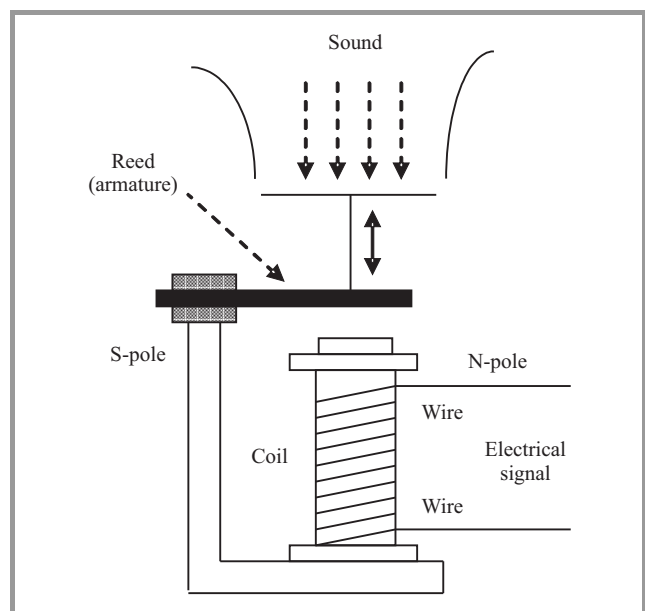

Fig. 5. Conversion of vibrations to electrical signals.

At this point it is to note that inward diaphragm stroke produces current in one direction while outward diaphragm stroke produces current in opposite direction. This oppos-

ing current has an effect to degradation of magnetic properties of a permanent magnet used and hence magnitude reverse current should never be great enough to nullify the reverse magnetism of core. Degradation of magnetic property leads to reduction of armature gap. Figure 5 presents typical magneto transmitter and receiver that can be used for voice transmission.

### 3. Telegraph and Telephone Experiment by Alexander Graham Bell

Bell used reed relays in his experimental setup [23], [24] to show that vibrations generated by tuning fork are picked up and converted to electrical pulses by reed relay at one end. These electrical pulses are sent over a pair of wires. At other end, yet another reed relay converts these electrical pulses back to vibrations. Figure 6 shows the representative experimental setup used by Bell experiment. He has used magneto design using soft iron instead of hard magnetized steel. The coil used in Bell's experiment is shown in Fig. 6.

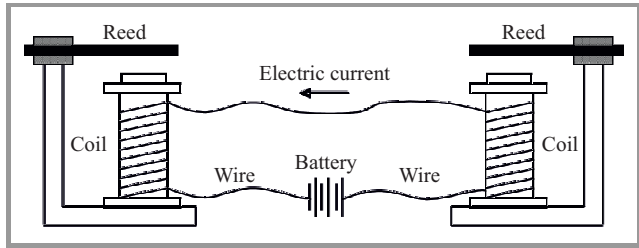

Fig. 6. Experimental setup used by Bell.

With this experiment, Bell was able to show that vibrations from sounds can be electrically transmitted from one end and reproduced at other end, can serve our purpose of communication to distant person. The dc current in the wire loop gets modulated due vibrations and variations in the current are sensed by a relay at other end. This experiment was the basis for further developments in telephony.

### 4. Developments of Microphones

To incorporate transmission of human voice required the sensor that can sense vibrations related to human voice for transmission over a device.

In 1827, Sir Charles Wheatstone made an instrument to amplify the weak signals and called it as microphone and from that time the phrase microphone existed [25]. Later on, Emile Berliner, invented first microphone in the year 1876 for converting a voice signal to electrical signals [26]. Emile Berliner filed a caveat on April 14, 1877, and then he advanced an application for United States patent on June 4, 1877 and to this effect he was awarded with a patent of "Contact telephone (US Patent No. 222652, December 16, 1879)". As per his invention, sound striking point of contact can cause pressure difference that is responsible for

producing a change in current related to sound. Its construction is shown in Fig. 7.

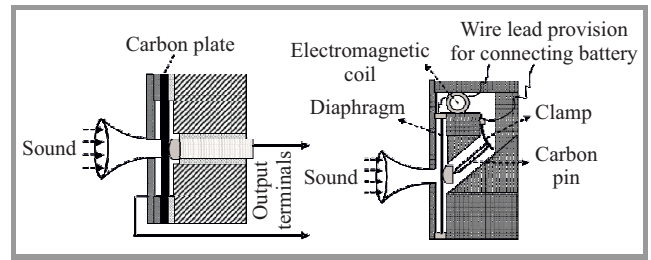

Fig. 7. Emile Berliner's microphones.

Later on Berliner filed a patent for improvement of microphone [27] on August 11, 1879. This invention consists of dispensing with the clamping device for fixing the carbon pin in position, maintaining a contact with diaphragm under gravity (Fig. 7).

He also invented the transformer that prevents signals from weakening. These inventions were responsible for transforming Reis's and Meucci's telephone instruments to practical one. Both Emile Berliner and Thomas Alva Edison filed the patents for carbon microphone. The Berliner filed his patents in the years 1877 and 1879 while Thomas Alva Edison filed patent in the year March 1878. However, in 1892, Thomas Alva Edison won the legal battle on the pretext that "Edison preceded Berliner in the transmission of speech" [28]. Carbon microphone [29], [30] invented by Edison can convert human voice to electrical signal to be put on dc current loop responsible for long distance voice communication.

The carbon-button microphone invented by Edison generated better signals. The mechanism consisted of carbon button [19] formed out of carbon powder collected from kerosene lamp and chimneys, which was pressed into a compact button form. A change of resistance of this button occurred due to sound pressure and hence changes of current which is representative of voice. The Edison's carbon transmitter is shown in Fig. 8.

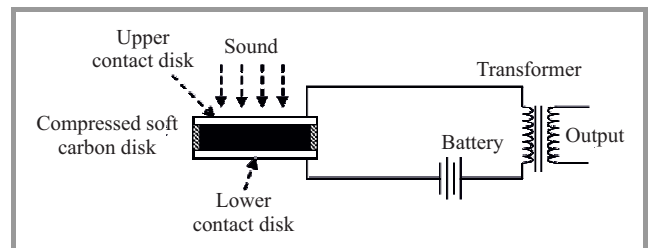

Fig. 8. Edison's carbon microphone.

One of the early models of carbon microphone was invented by David Edwards Hughes [31]–[33] in 1878. His inventions were truly adopted. He was critical of disclosing his invention first to Royal Society rather than patenting it. Before such disclosures, he even refused to patent his inventions. The Hughes microphone is shown in Fig. 9.

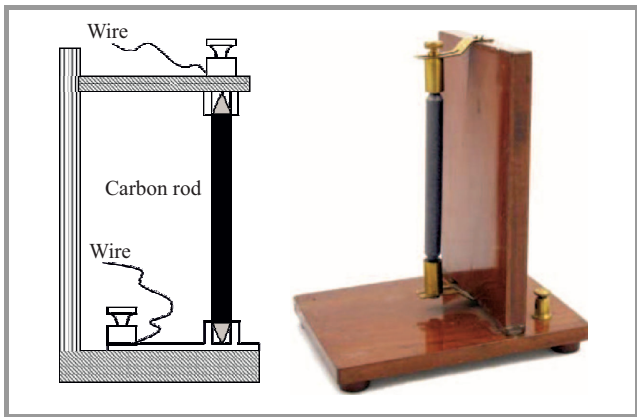

Fig. 9. Hughes carbon microphone.

Dynamic moving coil microphones were introduced by Ernst Siemens in 1874, and during 1916, at Bell labs, wide range quality condenser microphones was developed by Wente [34]. Dynamic moving coil microphones were also introduced in late 1920 by Wente and Thurman.

#### 4.1. Carbon Microphone

Figure 10 shows the construction of carbon microphone and associated circuit. The microphone consists of cup containing carbon granules. Cup is covered with the diaphragm such that both diaphragm and cup are electrically isolated to act as two terminals. As matter of fact, they acts as two points of resistance, which varies as per the sound vibrations. Certain amount dc current is passed through the series combination of microphone and primary winding of the transformer. The dc current varies through the circuit when resistance of carbon microphone is changed due to sound waves striking the diaphragms giving the output at the secondary side.

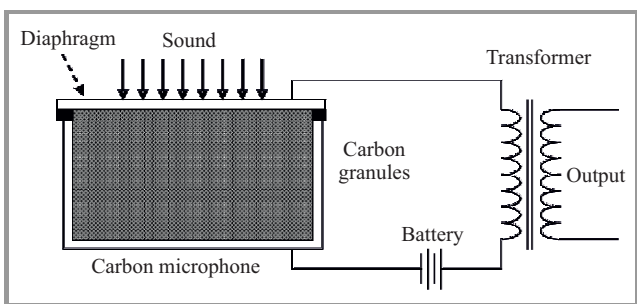

Fig. 10. Carbon microphone circuit.

Since carbon microphone uses carbon granules in the cavity between its two terminals, the granules in motion give rise to some amount of random variation in resistance leading to constant hiss affecting signal to noise performance of the microphone. However it has high sensitivity (about 100 mV of output signal). The carbon microphones were become standard in early days of telephony.

#### 4.2. Magnetolectric Moving Coil Dynamic Microphone

The moving coil dynamic microphone consists of voice coil attached to a diaphragm that vibrates due to variable sound pressures. The principle of working is explained by Fig. 11 which consists of two parts, one part is permanent magnet and other is a coil itself. The flux created by the permanent magnet between its north and south poles. When sound vibrations strike on the on the diaphragm vibrates, that is responsible creating the coil movements within a flux created by north and south poles of permanent magnet, intern that also creates an electrical output voltage at the ends of electric coil equivalent the magnitude of sound created near to the diaphragm.

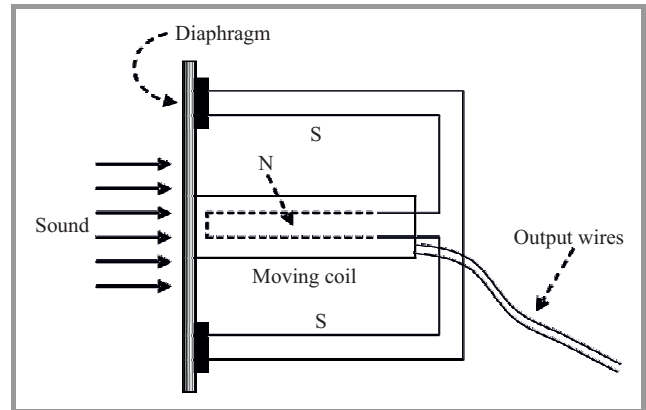

Fig. 11. Moving coil dynamic microphone.

#### 4.3. Condenser Microphone

In condenser microphone the capacitance offered by two parallel plates is varied by sound waves, resulting in varying charge across the capacitor. The charge variation produces change of current in the circuit and further change of voltage across the resistance that is, dependent on sound waves (Fig. 12).

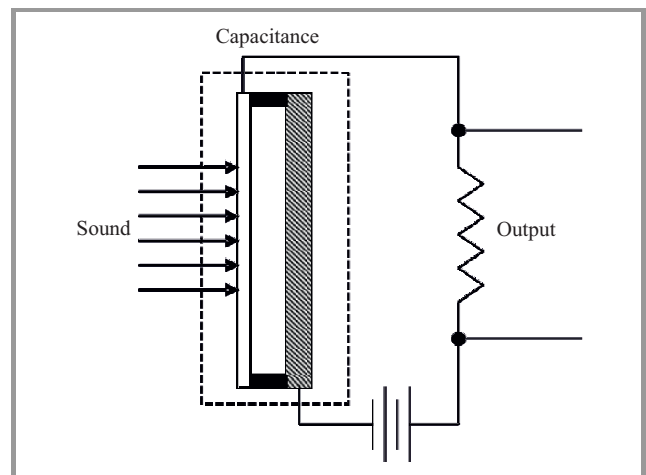

Fig. 12. Condenser microphone.

The inventions related to telegraphy and telephony made lot of impacts on the world of telecommunications. In tele-



phony, microphone severed as critical block for the entry of voice into the telephone experiment by Bell, which made use of tuning forks.

## 5. Bell's Experiments for Voice Transmission

Articulation of voice using Bell's initial experiment predicted the shape and manner in which things to come in future. The efforts were on for coupling voice to circuit invented by Bell [24].

### 5.1. Bell's Liquid Transmitter

On March 10, 1876, Bell successfully passed sounds from one end to other end [12], [16], [22], [33], [35]– [39]. This experiment was conducted using Bell's liquid transmitter. In this experiment, instead of using tuning fork, the human voice is allowed to strike diaphragm which in turn, drives a conducting rod just making the contact with the acid placed in a cup. The cup body and conducting rod act as variable resistance whose resistance is varied depending on voice. This arrangement converts voice to electrical signals to be carried over Bell's initial experiment (Fig. 13).

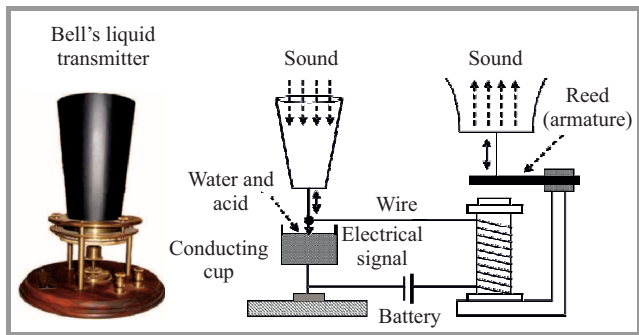

Fig. 13. Bell's voice experiment using liquid transmitter.

### 5.2. Bell's Centennial Telephone Model

The Bell's liquid transmitter was not convenient for use and hence he developed yet another transmitter free from use of any liquid, which was called as Bell's centennial model [16], [33], [40]–[44]. This model used electromagnetic transmitter, metal diaphragm and permanent magnet [42] (Fig. 14).

Since Bell's initial experiment served as a solid base for voice transmission, the ways for sound conversion were invented. Electromagnetic devices using soft iron and not of hard magnetized steel played important role in the conversion of sound waves to electrical signals and vice versa using such conversion as shown in Fig. 15. The voice coupled to electromagnetic device was clearly and distinctly heard at other end. Figure 15a shows the type of arrangements used while Fig. 15b shows circuit representation. The pull upon the diaphragm is provided by the flux that is

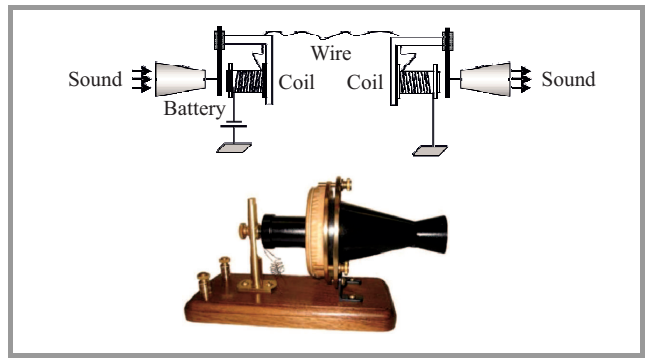

Fig. 14. Bell's centennial telephone.

generated by the loop current due to battery, which is inserted in series with the line and not by flux due permanent magnet as in earlier cases.

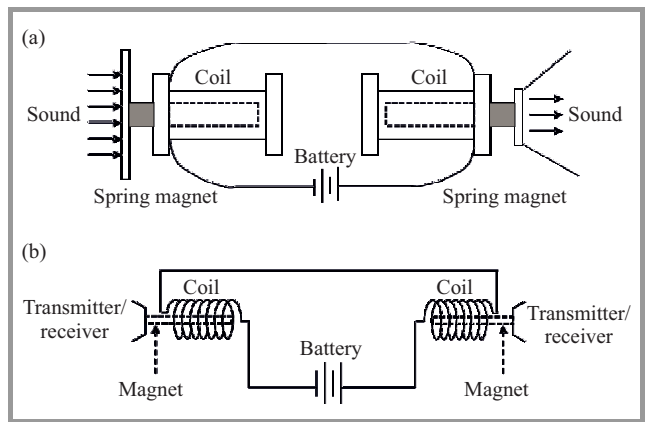

Fig. 15. Principle of voice transmission using electromagnetic coils.

At both the ends electromagnetic devices are used for conversion of voice signals to electrical signals and vice versa. The diaphragms are attached to spring magnets for such conversion leading to such novel invention that became an eye opener for the development of systems related to telephony.

## 6. Next Inventions

After success of Bell's experiments for voice transmission, he continued with his experiments for calling distant person. At the end of 1876, due to earlier Bell's experiment, Boston experienced intense telephone activities and served as a center of telephone activities and many private telephone lines started coming up. In many cases existing telegraph lines used for connecting equipments on these telegraph lines were replaced by early type telephone instruments.

Later on, October 9, 1876, the experiment was performed by attaching telephones to both ends of 2 mile (3.2 km) telegraph line between Boston and Cambridge that was owned by the Walworth manufacturing company for con-

necting their office in Boston and factory in Cambridge. In this type of experiment, nine Daniell cells were used as battery [46], [47]. However, lot was to be done for commercialization of telephone.

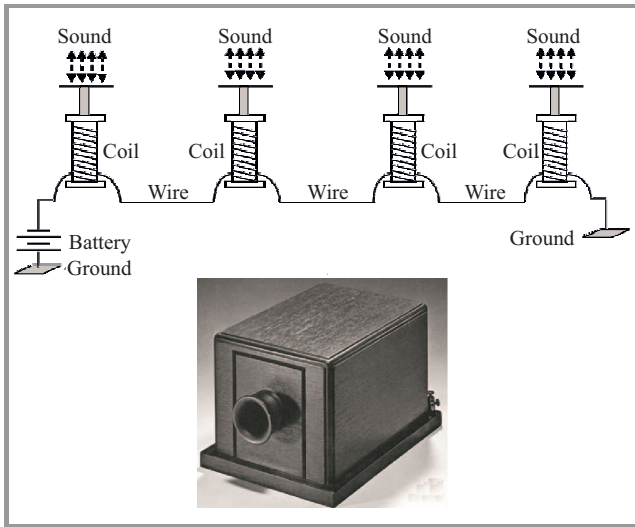

Fig. 16. Bell's box telephone connections and model.

On 30 January 1877, yet another patent [17], [48] was granted to Bell for an electromagnetic telephone using permanent magnets, iron diaphragms, and a call bell. Based on this second patent [48]–[50], a box telephone (looking like camera) was designed. A camera like opening on box served as a place for both transmitter and receiver. The box telephone was the first commercial telephone and a Boston banker was first to lease this type of instrument for connecting his office and home in Somerville, Mass. There were many difficulties using box telephone such as one can either talk or listen and signaling to the party at other end was done by tapping on the diaphragm. The figures related to patent of Bell's box telephone are shown in Fig. 16 [51].

6.1. Telephone Line Configurations

The conversation between any two customers out of any n customers requires direct wire connection between these two customers. So if a network of 2 telephones is to be formulated, it required  $2(2 - 1)/2 = 1$  connections, similarly if a network of three telephones to be designed,  $3(3 - 1)/2 = 3$  connections are required. By generalizing this concept for n telephones e  $n(n - 1)/2$  connections or links are required. This is shown in Fig. 17.

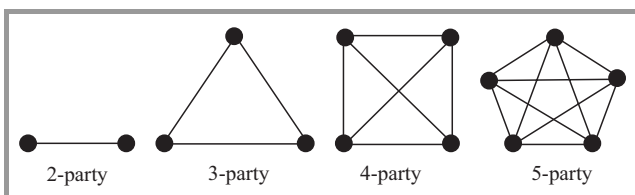

Fig. 17. General telephone networking concepts.

In order to reduce number of telephone lines, concepts of line sharing was put forward. These arrangements are called as party lines [16]. Single party line is used to serve more than two stations including the central office as one of the station if any. Some autonomous company using its own exchange for its private cause having its own lines are called as private lines. These lines are used to connect two or more isolated stations. However, private lines working in conjunction with telephone exchange may be called as party line, which may not seem to be consistent with the basic definition. There are two types of party line configurations called as series configurations and bridged configurations.

The earliest type of grounded-circuit series party line configuration is shown in Fig. 16. The box telephones worked on grounded circuit series configuration while Butter stamp telephones worked on grounded bridged configurations (Fig. 18).

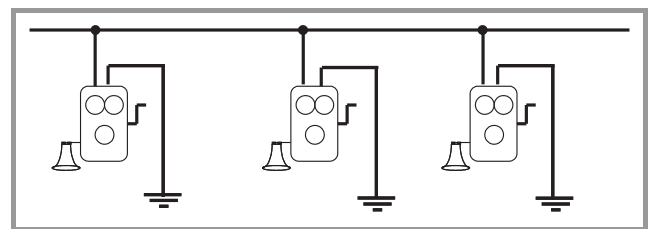

Fig. 18. Party line grounded bridged configuration.

In 1881, John Joseph Carty, an electrical engineer working in Bell's manufacturing unit called Western Electric Co. demonstrated advantages of two wire metallic circuit and after this, metallic party line configurations became popular (Fig. 19).

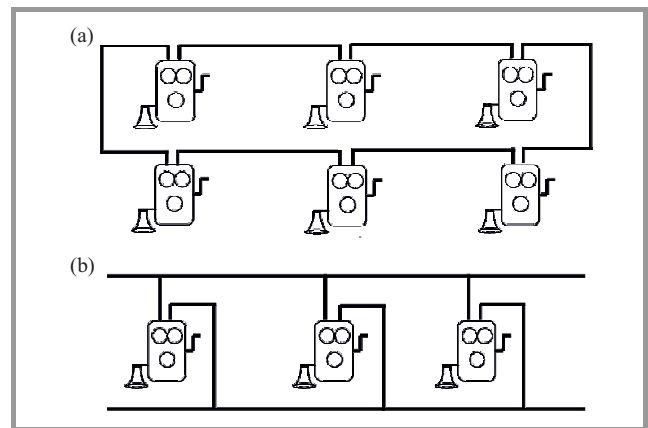

Fig. 19. Party lines metallic configurations: (a) with series connection, (b) bridge configuration.

6.2. World's First Long Distance Telephone Line

The world's first long distance telephone line was setup between French Corral mining campus and French lake (58 miles, 93 km) [52]–[54] in California, USA in 1877 and had 22 telephones. This link was built by Ridge Tele-

phone Company [55] and operated by Milton Mining Co. Line was operated using “Edison’s speaking telephones” [56]. Meanwhile, in 1877, Tivadar Puskas designed first telephone exchange for Thomas Edison [57].

In April 15, 1877, first regular 3 mile (4.8 km) telephone line was established from Boston to Somerville, Massachusetts [39], [58] which was the first commercial service in USA. Up to 1880, the customers’ number grew up to 47900, while in the year 1878, workable exchange was developed for enabling call switching amongst various customers.

**6.3. Butter Stamp Telephone**

Bell’s box telephone model (combined receiver/transmitter) was not so convenient to use because of its shape and hence it was modified to hand held telephone unit. This wooden hand held telephone came in existence in May 1877 [60]. This telephone model was attached to a base terminal stand using flexible wire cable.

To initiate a call, the operator at central place was being alerted using push button circuit [16], [61]–[63]. It used permanent bar magnet over which coil was wound to pick and reproduce the sounds. It looked like butter stamp that was common at the time and hence the name (Fig. 20). In this telephone, although both transmitting and receiving functions were performed by same mechanism, transmission of sound was poor as compared to received signal.

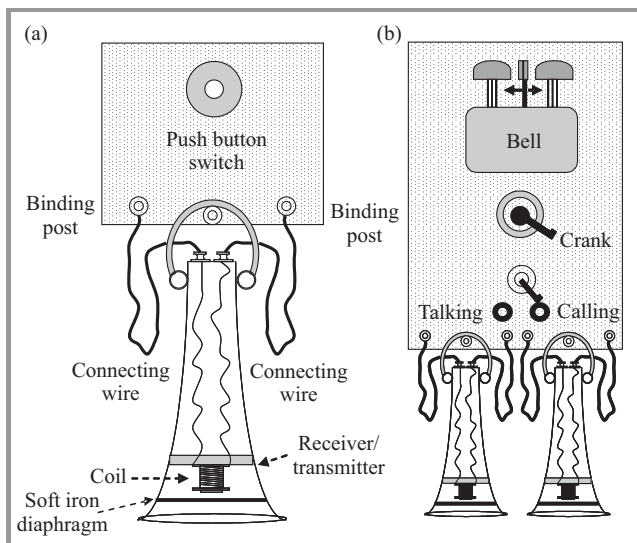
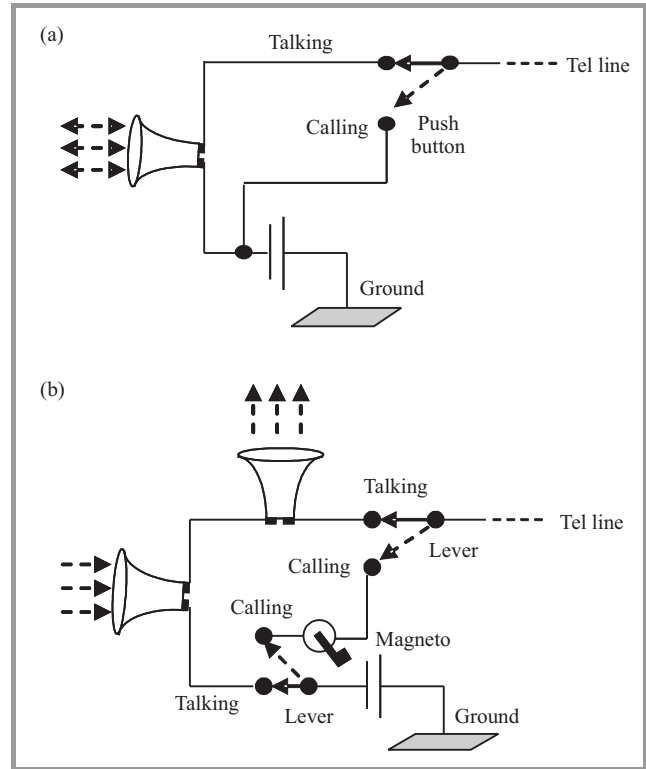

**Fig. 20.** Two wall units using butter stamp telephones: (a) basic model, (b) the modified version.

The single combined wooden hand held transmitter and receiver telephone was not still convenient to use for both taking and listening, hence two such units are used, one dedicated for speaking and other for listening. The model had come in the form of wall unit. Instead of push button, it used a crank to signal the operator to initiate that call is being initiated when “calling/talking lever” is set to

“calling”. In next version a bell was also added a to indicate incoming call when “calling/talking lever” is set to “talking” (Fig. 20b).

The circuits related to both the cases of wall units of butter stamp telephones are shown in Fig. 21. The first circuit (Fig. 21a) shows single unit while in other circuit (Fig. 21b) shows the modified device.



**Fig. 21.** Butter stamp telephone circuits: (a) single unit, (b) the modified version with separated transmitter and receiver.

**6.4. 1877 – A Year of Public Acceptance of Telephone**

1877 was the year of telephone business, and also an official and public recognition of telephone on existing telegraph lines, which helped the rapid spread of telephone services. On July 9, 1877 Bell transferred all the rights of this telephone to Mr. Hubbard and by July 31, 1877, as many as 778 telephones were leased to public by Mr. Hubbard [46]. By the end of year 1877 total of 5491 telephones of Bell were leased. On August 1, 1877, Hubbard organized an association called Bell Telephone Association of Boston and acted as its trustee while Sanders as treasurer. Bell, Sanders and Hubbard created in 1878 company called Bell Telephone Company (BTC) [17], predecessor of today’s AT&T.

In USA, on October 24, 1877, two lease deeds for territorial rights were executed with Telephone and Telegraph construction Company, Detroit, Michigan and District telephone Company, New Haven, Connecticut. However District telephone Company, New Haven, Connecticut could take the lead in establishing world’s first telephone exchange [16].

### 6.5. Developments at Western Electrical Manufacturing Company

Elisha Gray was also working on the invention of telephone and fought legal battle with Bell. However, Bell won the legal battle on the basis that Bell had working experimental model. Meanwhile, telecommunication industries started to take off. A Telegraph Industry Supply Company (TISC) was founded in 1869 by Elisha Gray and Enos Barton. Later on in 1872, the company changed its name to Western Electrical Manufacturing Company (WEMC).

The WEMC was the principal manufacturer for Western Union (WU). In 1877, WU decided to compete with Bell and entered in the commercial production of telephones [65]–[67]. It was also aware that although centennial model was successfully demonstrated at Philadelphia as well as Butter stamp telephone was successfully used, transmitter and receiver were notably weak in terms of voice signal conversion.

Owing to above weaknesses, it conducted extensive tests of various models of telephones designed by Edison, Gray and Phelps. The designs of Bell, Gray and George Phelps used magneto design. In earlier designs, magneto were used at both ends for speaking and listening created some sort of inconvenience to the user. After speaking, the same device was used for listening. Furthermore, telephones based on magneto were suffering from weaker signals when transmitted over longer distances.

Till 1875, Edison's concentration was on telegraphs related problems and did not bothered for working for telephony, during the same year Edison started working on carbon microphone. At the same time, Bell was concentrating on the work of sound conversion using electromagnetic principle. In 1876 Edison started working with Western Union and William Orton [28], [68], and concentrated on conversion

of sound using a pair or single carbon electrodes in contact with each other that was exposed to sound. This mechanism generated strong signals as compared to the principle of electromagnetic sound conversion. Orton pursued Edison for filing of the patent for which he paid 100,000 US dollars to Edison.

Edison's carbon microphone solved these problems of magneto design. In early 1878, Western Union evaluated Edison's carbon microphone for a link between New York and Philadelphia and determined that it has superior performance. While for receiving, Phelps multipole design [69] (Fig. 22) was used [28], [69], [70].

The Phelps design used number of magnets having their individual coils for efficient performance. This combined design was used in telephone exchange opened by Gold and Stock Telegraph Company (GSTC) in San Francisco in February 1878 and was marketed by Western Union of New York (run by Phelps) through their subsidiaries called American speaking telephone company (ASTC) and Gold and Stock Telegraph Company (GSTC) from 1877 to 1879.

### 6.6. World's First Manual Commercial Telephone Switchboard

The world's first manual commercial telephone exchange was developed by George W. Coy based on the talk of Bell regarding importance of exchanges in commercial telephone lines, Coy applied for franchise from BTC for New Heavens and Middlesex. Coy along with Herrick P. Frost and Walter Lewis established District Telephone Company of New Havens on January 15, 1878. The company grew rapidly in 1880, as it expanded. It was renamed to Connecticut Telephone and then Southern New England Telephone in 1882. This world's first manual commercial telephone exchange was went in operation in Boardman building at New Havens, Connecticut on January 28, 1878 [71], [72], which was designed by Coy himself. Initially this facility went in operation with 21 subscribers on 8 lines [73]. These exchanges were consisted of several hundred plug boards. Early switchboard was built from "carriage bolts, handles from teapot lids and bustle wire" and could handle two simultaneous conversations. Later exchanges consisted number of plug boards operated by the operators. Operator has to sit in front one to three banks of phone jacks fronted by several rows of phone cords, each of which was the local termination of a phone subscriber line. The constructed schematic switch board used in this exchange is shown in Fig. 23.

The switch board [74], [75] consists of four arms that can be rotated in circular fashion for making the contacts, party line terminations, annunciator, a strip along with contacts, operators telephone instrument and a calling device.

The switch board receives eight party lines and each party line caters to on an average twelve subscribers so that exchange had a capacity to serve to  $12 \times 8 = 96$  subscribers. The exchange also supports two simultaneous calls.

The operator can manipulate the connections using four rotating brass arms [76]. Out of these four arms, two arms

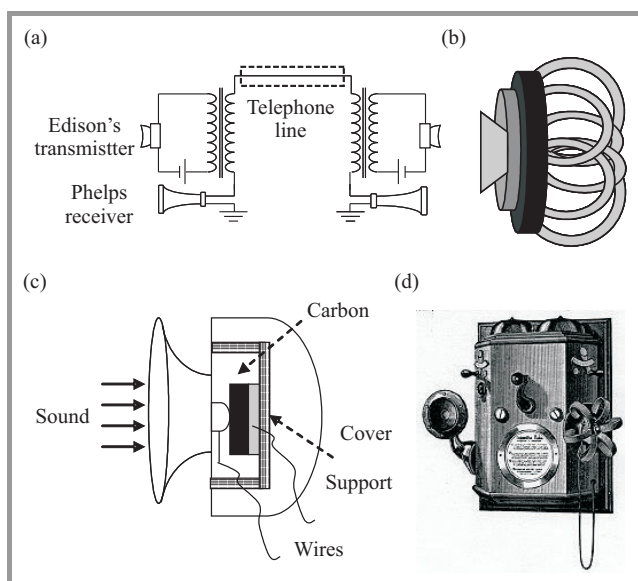

Fig. 22. Telephone model used in exchange opened in San Francisco in 1878: (a) schematic, (b) Phelps receiver, (c) Edison's carbon transmitter, (d) photo of telephone.



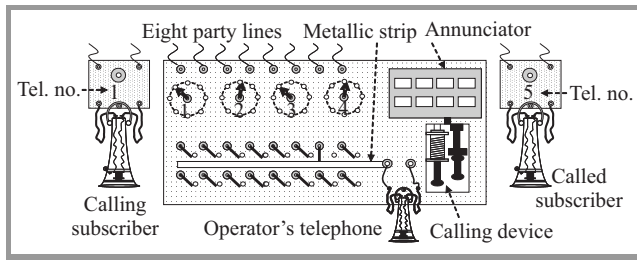

Fig. 23. Manual switch board at New Haven, Connecticut.

are used for connecting two subscriber wires (caller and called subscribers) on the switch board, third arm is used for connecting operator to circuit and fourth arm is used to ring called subscriber.

The call at that time was materialized as per the following sequence.

At first instance, caller draws the attention of switch board operator by pressing push button on his telephone that actuates a single stroke bell in the exchange. This action also releases a drop in annunciator indicating a party line to which caller is attached (“1” in Fig. 23). On hearing the bell and knowing the calling party line from the annunciator display, operator moves third rotating arm to 7 and also turn respective “single switch (no. 7)” to metallic strip to connect his telephone (operator’s telephone) to a caller’s telephone for inquiring the subscriber to whom he wants to connect. After knowing the identity of party to be called, “single switch” is moved off position.

During next step, calling device (also called as Watson’s Squealer or Coy’s chicken) is attached to a party line on which subscriber being called is attached (say party being called is attached to party line 8 with subscriber or telephone number is 5). Then calling device is attached to line number 8 using fourth rotating arm. The attached device is then used to send 5 long squeals over this line to indicate that this call is for subscriber 5 and not for others.

To establish connection between caller and called party, first and second arms are used. The arm of first circle is rotated to respective position of calling subscriber line (7) while arm related to other circle was set to calling subscriber line (8). The butter stamp telephones were to communicate through this exchange established at New Haven. In February 21, 1878. The telephone directory related to its 21 customer was published.

**6.7. Origination of PSTN Concept**

Although first commercial telephone exchange at New Haven was opened by BTC, as on 1877, Western union had lot of potential in terms of its already existing 250,000 miles of telegraph lines covering 100,000 miles route [77] and had unchallenged monopoly for making it a largest telecom company at that time. However, this monopoly was later on ended because of the role of Bell’s shrewd lawyer. On February 17, 1878, Western Union, on the basis of its

capacity, opened its first large city exchange with 18 phones in San Francisco [78], [79] that enabled any of the users to talk to any other using different lines rather than dedicated lines that generated a concept of Public Switched Telephone Network (PSTN).

The year 1878 was a year of many firsts, telephones exchanges spread quickly to other locations and was a year of commercial spread of telephones. It included opening of first telephone exchange at Albany, New York state on March 18, 1878 [80] and first telephone exchange at Lowell, Massachusetts on April 19, 1878. In telephone exchange, at Lowell, telephones were designated by the numbers [81], [82]. Earlier to this, operators simply knew the plug related to the customer telephone. The first telephone exchange outside United States was set up in Hamilton, Ontario, Canada on July 15, 1878.

These earliest telephone lines were called as grounded lines [83] in which only one wire is used for carrying currents related to telephone metal while other point is a ground point. The grounded line telephone system is shown in Fig. 22a. At later stages, two wire telephone systems were used and these circuits using two wires were referred as metallic circuits.

There were some advantages of grounded configurations such as less cost of lines due its use of only one wire. The batteries were used locally at each end and there was no central provisioning of dc voltage supply by telephone companies. The multiple users can be configured as shown in Fig. 24.

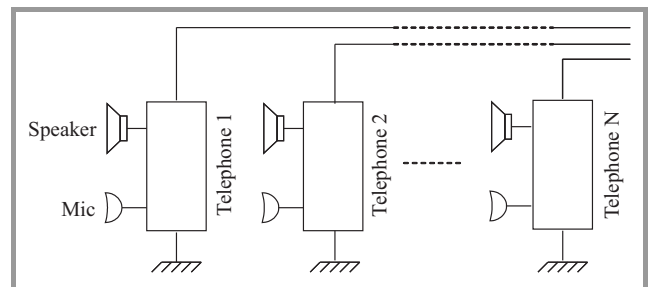

Fig. 24. Grounded telephone line configurations.

**6.8. Thomas Watson Files Patent for a Ringer**

On August 1, 1878 Thomas Watson files a patent for ringer [84], however, crude bells were in use in earlier telephones. It was similar to Henry’s class room door bell. Hammer strikes two bells was that is attached to an armature with magnetic field strengthened by permanent magnet that moves due ringer current. The patent was awarded on Dec 17, 1878. These rings were operated by AC current produced by magneto of calling end telephone.

**7. Blake’s Transmitter**

On other side of the developments, BTC was using a transmitter invented by Berliner [87], [88]. However, BTC was

not satisfied with its performance and hence it was modified by Francis Blake Jr. However, during this period of developments, Bell continued to use Berliner's transmitter till 1879.

Although centennial model was successfully demonstrated at Philadelphia as well as Butter stamp telephone was successfully used, transmitter and receiver were notably weak in terms of voice to signal conversion and signal to voice conversion respectively. Blake promptly identified this weakness and started working towards this problem and produced the working model that was taken to BTC offices in Boston for testing on October 18, 1878 [89], [90]. After testing it, Watson had no doubt that this was better transmitter as compared to any of the transmitters available at that time. Blake used carbon and platinum resistance elements which was again improved later by Berliner and remained standard for many years. Blake provided commercially viable solution for transmitter to a BTC. Figure 25 shows photograph and schematic of Blake's transmitter.

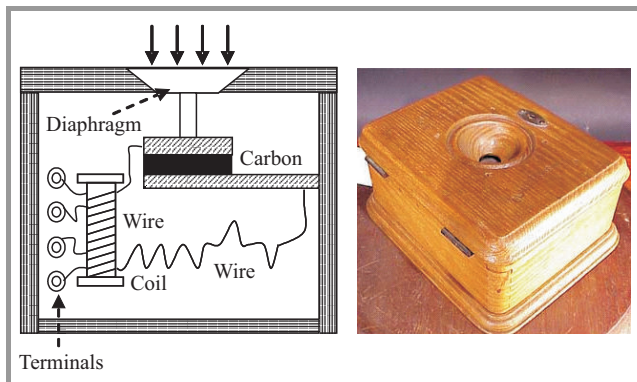

Fig. 25. The Blake transmitter.

The Blake transmitter was powered using local wet batteries [46], [92], which was not so convenient for use due to acid leaks. Blake transmitter was based on the modification of Edison's carbon transmitter patent owned by Western Union Telegraph company and that is the reason why Bell could not adopt the device invented by Edison. Subsequently Bell acquired the patent rights of Edison's patents through the successful lawsuits against Western Union Telegraph Company. This opened new avenues for BTC that accelerated the use of carbon transmitter in the form of Blake transmitter.

It is interesting to note that customer side telephone equipment was then consisted of many modules such magneto receiver (Bells's hand receiver), Blake transmitter and battery pack (at the bottom) (Fig. 28), while in some cases transmitter is located at the left side of magneto receiver.

## 8. The Automatic Calls Switching

During 1879, M. D. Connolly and T. J. Mc Tighe [93]–[95] discussed an idea of automatic switching with their nephew Almon Brown Strowger and later on, Strowger was able to

put forward their idea practically. The application for first dial telephone exchange patent was advanced by a team of three persons M. D. Connolly, T. A. Connolly and T. J. Mc Tighe on September 10, 1879 and a team was awarded with a patent on December 9, 1879.

In 1880, the exchange in New Havens, served around 30,000 customers using 138 exchanges [63] and further till 1887, it expanded its customer base up to 150,000 customers using its 743 main exchanges and 44 branch exchanges. While in 1881, a 45 miles (72 km), a long distance telephone service between Boston and Providence, Rode Island was put up in operation. Handling of such large number of calls posed great difficulty in managing exchanges.

### 8.1. Metallic Circuits for Improvements in Quality of Signals

Mean while, in the year 1881, American Bell Telephone company purchased Western Electrical Manufacturing company and it become Bell's manufacturing arm. It was further renamed to Western Electric Co. During 1881 itself, John Joseph Carty [96], an electrical engineer working in Bell's manufacturing unit called Western Electric Co., demonstrated advantages of two wire metallic circuit over conventional single wire grounded telephone system in terms of quality of audio signal as it rejects common mode unwanted signals. This type of service was then introduced commercially in October 1881 and first metallic circuit multiple switch board was put in commercial service. The metallic circuit configuration is shown in Fig. 26.

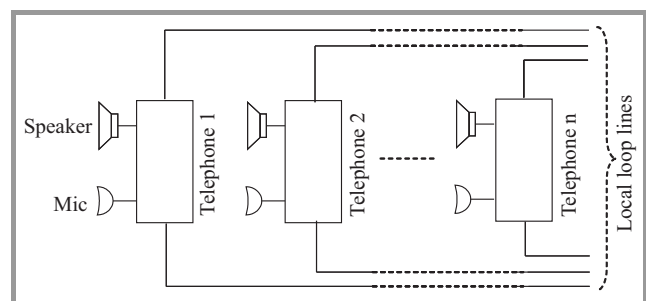

Fig. 26. Metallic circuit configurations (2 wire transmission).

There was a use of local battery in metallic circuit configurations and use of such local batteries was limited to only customer ends. These types of configurations had many drawbacks from the point of maintenance and continuous functioning of the telephone network.

Metallic circuits have become significant and iconic landmark in for circuit switching technologies and inventors started searching for the ways of metallic circuit switching in the following years. On January 17, 1882, Leroy B. Firman received the first patent [97] for a telephone switch board (Fig. 27).

This exchange is used to switch a pair of wires, for example, jumper/patchcord  $J_1$  is used to connect B and D wires while

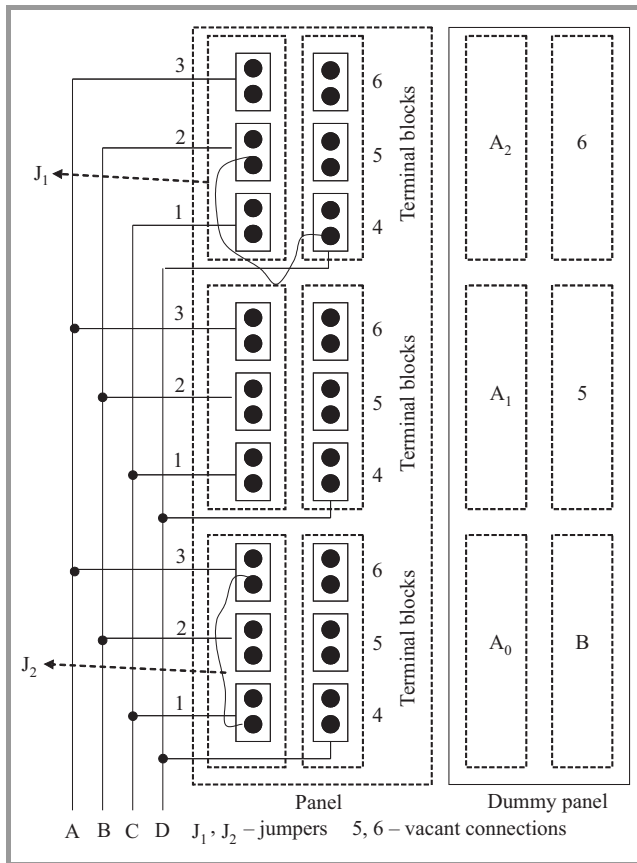

Fig. 27. Metallic circuit switching.

jumper/patchcord  $J_2$  is used to connect A and C wires. The dummy terminal blocks are used to indicate vacant places on dummy board.

During 1884, a copper based overhead transmission link covering a distance of 235 miles (378 km) was established between New York and Boston. Twisted wires helped to minimize disturbances on the lines and allowed to maintain the balance on the line.

**8.2. Commercial Use of Blake Transmitter**

From 1880, Vail started buying Western Electric instruments and during November 1881, virtually market was controlled by Bell. After February 26, 1882, Western Electric gave up its remaining patent rights. During this time the telephone instrument of Fig. 28 was used by Bell which was an integration of Bell receiver and Blake transmitter on a wooden panel using wooden cases to form magneto wall unit [98], [99] made supplied by Western Electric to Bell System.

Circuit diagram of wall mounted magneto telephone unit is shown in Fig. 29 [100], [101].

The circuit consists of receiver, transmitter, transformer, magneto, ringer magneto switch and hook switch. While calling caller opens magneto switch to disconnect receiver and transmitter circuit and signals the operator by cranking the magneto (when cranked, magneto generates 80–100 V AC at 20 Hz). After signaling the operator, caller closes the

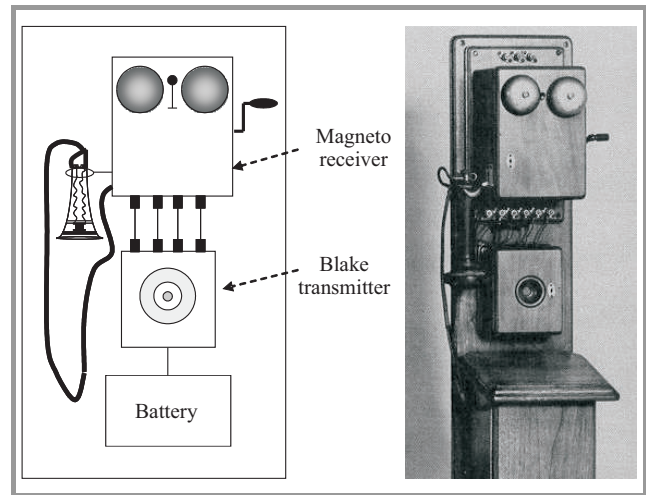

Fig. 28. Magneto wall set and its photograph.

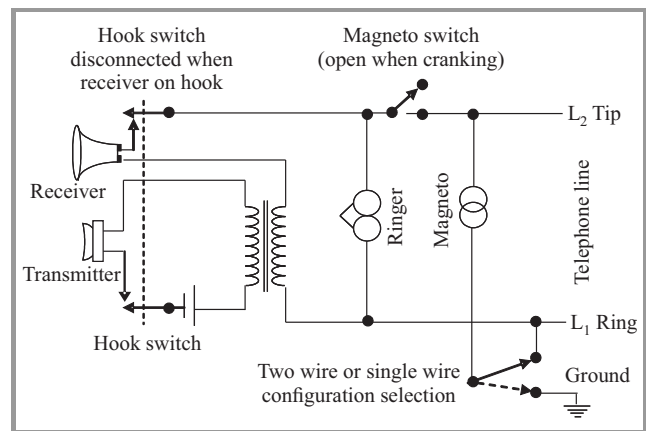

Fig. 29. Circuit for wall magneto telephone.

magneto switch. Operator, after locating and connecting the party to the caller’s line, signals the caller by activating the ringer. After hearing the ring, caller lifts the receiver from the hook switch to talk to the concerned party. The magneto can be connected between tip and ring or tip and ground depending on number of lines used for carrying the signals to the operator. Normally two wire loop consisting of tip and ring is used, which is also called as metallic circuit. In such case magneto is connected between tip and ring, while in order to maintain the compatibility with earlier single line transmission, magneto is connected between tip and ground.

**8.3. Introduction of phantom circuits**

Increase in telephone customer base was resulted in crowding of skylines of every city with telephone wires, and it was high time for reduction in crowding of telephone lines. To some extent, phantom circuits were able to serve this purpose.

During 1882, Frank Jacob proposed to connect three telephones circuits using two pairs of telephone lines. This allows to connect three telephone circuits using 4 wires in-

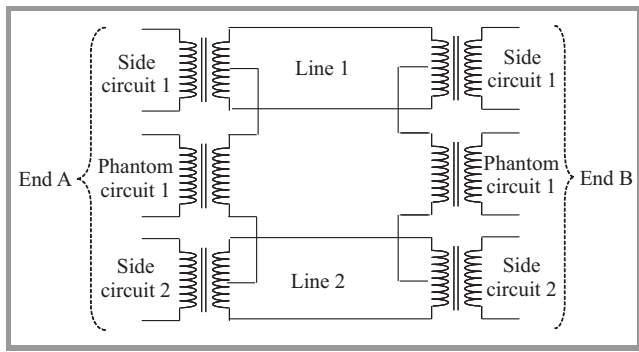

Fig. 30. Phantom circuit.

stead of 6 wires saving a pairs of wires which otherwise was required. It was possible by combining two simplex circuits. The additional circuit derived is called as phantom circuit (Fig. 30). In this arrangement, third circuit is derived by center tapping repeat coils at both the ends of two telephones lines. The phantom circuits were first used by John J. Carty in 1886 [102].

#### 8.4. Formation of AT&T

In 1879 the Bell Telephone Company was renamed as National Bell Telephone Company [17]. It became American Bell Telephone Company in 1880. In the same year it started Long Distance Telephone Line (LDTL) project to create nationwide telephone network, where all most all wires were running above the ground before the year 1900 [103]. It required separate company to be established for such stupendous task. Hence, during 1885, BTC launched its new subsidiary called American Telephone and Telegraph (AT&T) which completes its first line, between New York and Philadelphia. Acquisition of Western Electric in 1891, paved a way for subsequent formation of Bell Laboratories. In 1892, AT&T established long distance telephone network from New York to Chicago.

#### 8.5. Need of Common Battery Telephone System

Till now, the batteries were used locally, caused lot of irregularity in maintaining batteries at local ends and hence it was felt that batteries at some fixed place owned by telephone company can reduce the down time of the network. This will also facilitate the future signaling mechanisms. In wake of these developments, common battery system was developed by Hammond V. Hayes in 1888, in which, customers are connected locally to central office through local lines supplying current to the customers without use of any power source at the customer premises.

#### 8.6. Telephone Numbering

Prior to 1889, subscribers were designated by the names, which acted as unique identification of the telephone sub-

scribers. It was then thought that instead of using wide ranging A to Z characters, one can use 0 to 9 digits. The main advantage is hierarchical and modular periodicities that can very well address the issue of identification of subscriber. During 1889, telephone subscribers began to be designated by numbers rather than names. The basic purpose of designating subscriber by number is to uniquely identify the subscriber. The telephone number is a string of decimal digits that uniquely identifies network termination point. The telephone number contains information necessary to route the information to that particular telephone number. It is a uniform resource identifier (URI) for a particular telephone related to a particular subscriber [104].

#### 8.7. Extending Telephone Lines Using Loading Coils

During 1889 to 1899 many telephones lines went in to service and many cities were connected. The cities such as New York-Chicago (1892), Boston-Chicago (1893), New York-Cincinnati (1893), Chicago-Nashville(1895), Kansas City-Omaha (1896), New York-St. Louis (1896), New York-Charleston (1897), New York-Minneapolis (1897), New York-Norfolk (1897) and New York-Kansas City (1898) got connected. The telephone wire running distances went up. This needed signal boosting and conditioning on the telephone lines called regeneration using line repeaters. In 1899, Mihajlo Idvorski Pupin [105]–[108] (also known as Michael I. Pupin), working at Columbia University invented loading coils that permitted construction of longer telephone lines (Fig. 31).

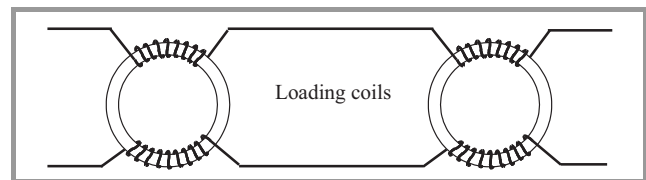

Fig. 31. Loading coils in telephone lines.

Loading coils are inserted at the distance of every 1.24 mile (2 km). Analog telephone line consists of a balanced pair of twisted wires with characteristic impedance terminations of 600 or 900  $\Omega$ . These terminations are engineered to match amplitude and frequency characteristics of voice signals carried by telephone lines.

First time, AT&T installed Puppin coils in 1906 on its 10.5 mile (17 kilometers) line between New York and Newark, New Jersey in the year 1902, while introduction of 250 mH loading coils [37] of at every 1.14 mile (1.85 km) interval on other cables between New York-New Havens and New York-Philadelphia followed. Before introduction of amplifiers, the longest loaded cable was between Boston and Washington through New York. In 1920, all loading coils were removed to give a way for use of amplifiers.



## 9. Strowger Switch – the Facilitator for Automatic Exchanges

Almon Strowger, an undertaker in Topeka, Kansas invents automatic telephone switch and on March 12, 1889, he filed an application for patent [109]–[111] which was granted on March 10, 1891. The Strowger switch (Fig. 32), was a device that led to the automation of the telephone circuit switching. It was the first automatic commercial dial system. In simple words, initial Strowger switch can be viewed as 1 pole 10 position switch that can connect one of the 10 destinations. To operate such a switch electrically using electromagnetic devices, it requires two relays for advancing the contacts depending on the destination telephone number to be contacted while other relay is used for resetting the contacts home position. This represents one pole ten position automated contact selector switch, also called as uniselector switch. Simple demonstration of such a switch is shown in Fig. 32.

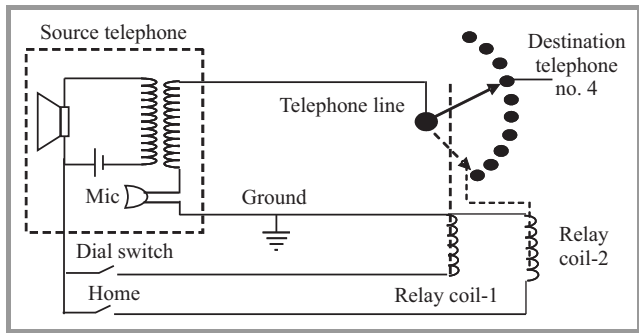

Fig. 32. Uniselector automatic Strowger switch.

To increase the capacity to more destinations, 1 pole 10 contacts wafers are stacked together [112]. If 10 wafers are stacked, one can increase capacity to 100 destinations, but instead of 10 poles, the pole contact is moved vertically up or down to select destination is called as group selector switch. Each wafer can be viewed as uniselector in which contacts are moved laterally/rotated in one plane. The switch consisting of 10 such wafers involving vertical and lateral movements is called as biselector switch (Fig. 33).

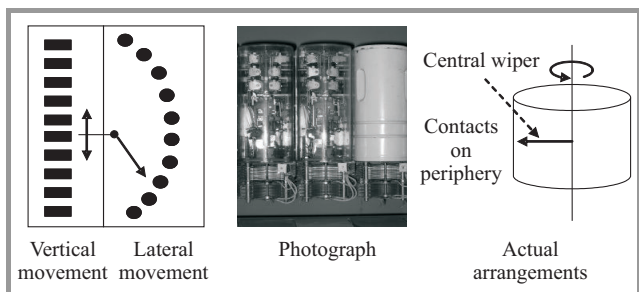

Fig. 33. Biselective Strowger switch.

The biselector switch was housed in a metal can for purpose of use in actual commercial exchanges. It was operated

using three electromagnetic coils, first coil is used to step relay upwards to next deck of contacts, and second coil is used to rotate the contacts in a deck and third coil is used for resting the contacts to home position in which lateral contacts rotate to extremely left position in the decks and vertical contact falls down to a bottom position. The following detailed figure (Fig. 34) may clear all doubts that reader may have in his mind.

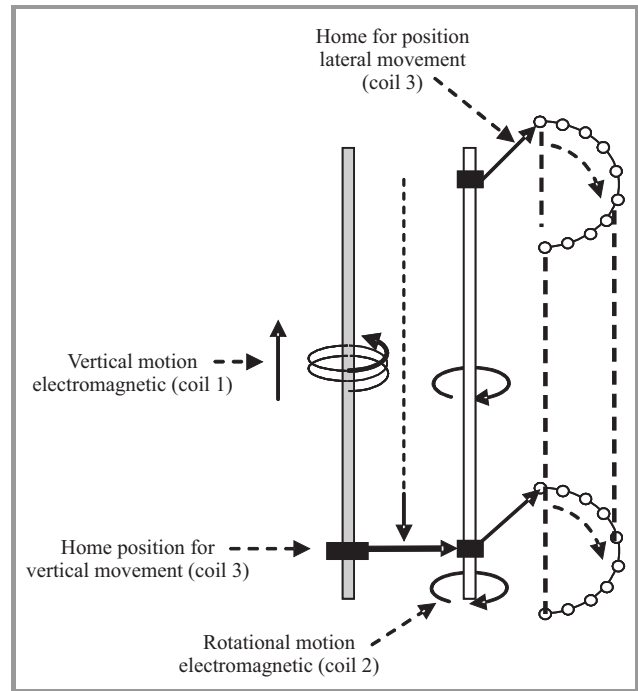

Fig. 34. Biselector switch functioning details.

Strowger was the first person who really invented automatic means of communication between two telephone users.

### 9.1. First Commercial Exchange Using Strowger Switch

Strowger Automatic Telephone Exchange Company (SATEC), Chicago was formed in October 30, 1891. Early of 1892, A. E. Keith joined the SATEC and installed and opened the world's first automatic commercial exchange [110], [113] in then home town of Strowger, La Porte, Indiana on November 3, 1892, with about 75 subscribers and capacity for 99, which indicates that using single biselective switch one can control 99 connections using two push button switches. First push button caused the switch to move its position up and down to select a wafer in a particular row dictated by a 10th place digit of telephone number while using second push button, in a selected wafer, a particular contact is selected based on a unit place digit of telephone number. Thus, if we want to connect telephone number 63, first switch is pushed 6 times to select 6th wafer in 6th row while other switch is pushed three times to move the contact at 3rd place. The third push button switch is used for disconnection.

### 9.2. Management of First Commercial Strowger Switch Exchange

Although, first installed commercial exchange was having capacity of 100, the patent filed by Strowger, explains the functioning of Strowger system having capacity of 1000 using four push buttons switches [110]. First three push buttons were used for selection of 3 digit telephone number and fourth switch is used for disconnecting the call after conversation is over. However, first commercial Strowger exchange having a capacity of 100 lines was implemented using biselector switch (Fig. 35), in which biselector switch moved in both vertical and horizontal direction to reach any one of 100 lines those are arranged in 10 groups having 10 lines each.

First set of dialed pulses (represented by first digit of destination telephone number) move the contact upwards

in vertical direction to select a particular wafer and within that particular wafer, contacts in the selected are continuously rotated horizontally to higher contact positions from home position till free trunk line is located. This arrangement now can be controlled using three push button switches having defined functions of controlling of vertical contacts, lateral contacts and returning to a home position the broad view of such exchange is shown in Fig. 36.

### 9.3. Five Wire Telephone Interface

In this exchange, electromagnetic relays were operated using push button switches arranged at tens place and units place. This exchange used two axes Strowger switch, a relay having three electromagnetic coils, first coil is responsible to step-up through various wafers arranged vertically selecting a particular wafer acting as deck of 10 contacts, while second coil rotates contact in a selected wafer. Finally a third coil resets the relay at home position. To have such arrangements, it required 5 wires interface between telephone and exchange, leading to a complicated wiring between telephone office and customer premises. In the example shown in Fig. 37, source telephone is connected to destination telephone (telephone number 63).

## 10. Opening of Long Distance Line by AT&T

During 1892, AT&T reaches its initial goal, opening a long distance line connecting New York and Chicago covering a distance of 950 miles (1528 km).

Few long distance circuits [115] introduced thereafter were New York to Havana, New York to New Orleans, New York to St. Louis, Boston to Chicago, Chicago to Denver, Chicago to Los Angeles, Chicago to San Francisco, Denver to San Francisco, Kansas City to Denver, Dallas to St. Louis.

Opening of this long distance line exposed the problems of long distance voice communication. An English physicist Heaviside developed the theory of transmission of signals over two wire metallic circuits and published a series of papers in 1892. Based on these papers, Michael I. Pupin and George A. Campbell realized that periodic use of inductive loading coils can reduce the loss of signals [107]. First application of loading coils occurred in 25 miles (40.2 km) Boston circuit during 1900. A line between New York and Denver with loading coils was opened by AT&T in 1909 [116], [117].

## 11. Introduction Common Battery Systems in Exchanges

The first common battery (CB) system for subscriber's telephone exchange was introduced in December, 1893 at Lexington, Massachusetts, before that subscribers required their own battery and hand operated magneto generator [37].

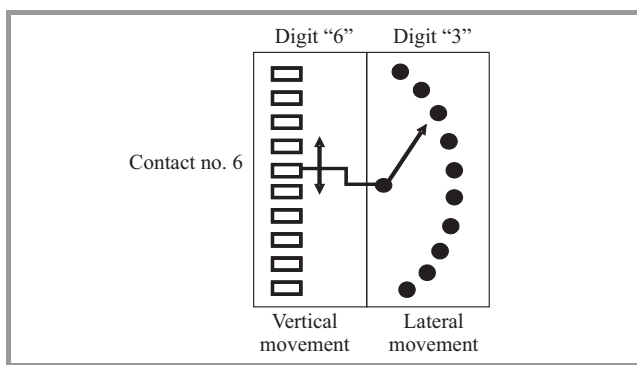

Fig. 35. Use of biselective Strowger switch for connecting destination telephone.

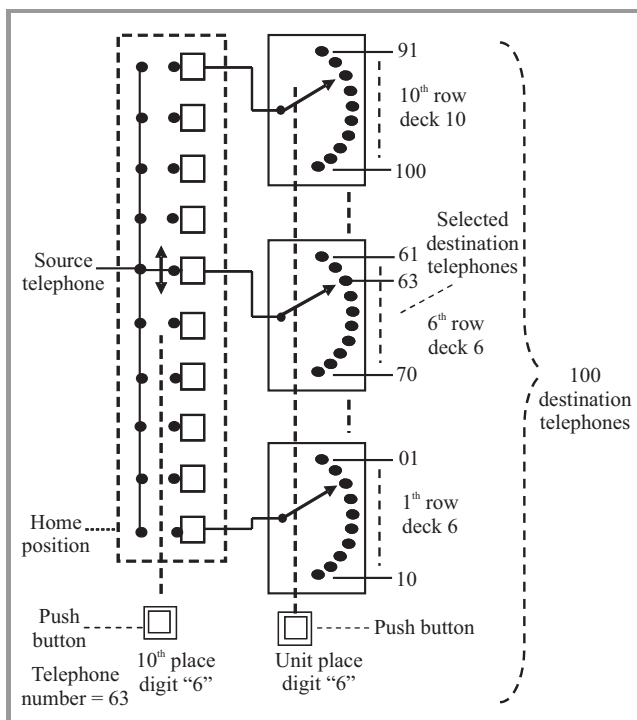

Fig. 36. First Strowger exchange principle.

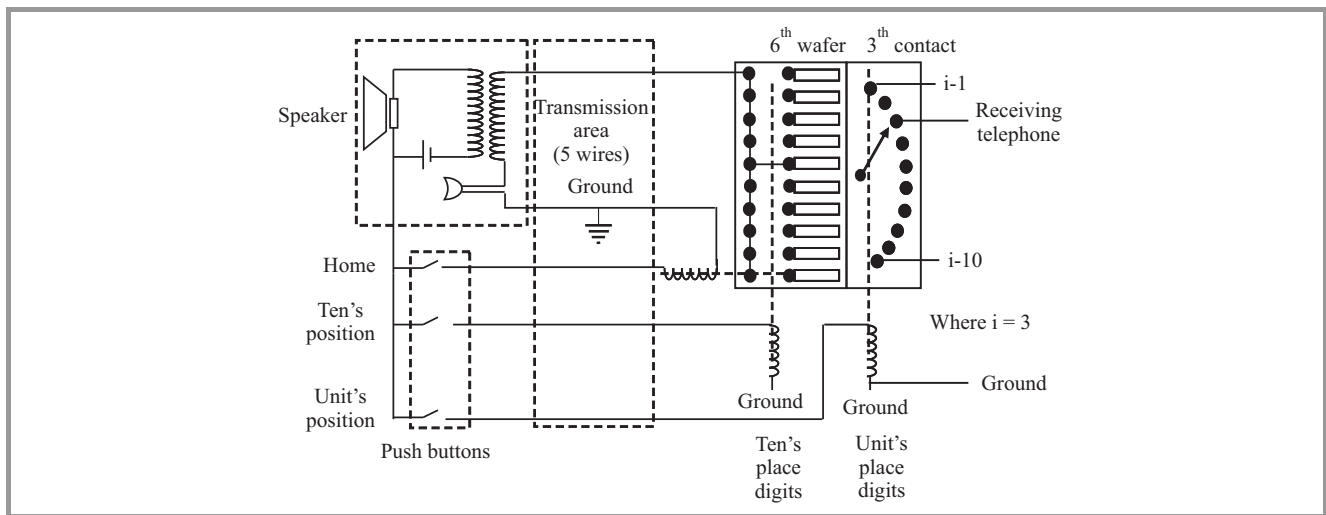

Fig. 37. Five wire telephone interface.

While, in Europe, common battery was introduced in the year 1900 at exchanges at Bristol, England and Adler-shof near Berlin, Germany. Initial CB systems had the problems of crosstalk, which was solved by using bridged impedance system introduced by Western Electric. After that, there was great acceptability for CB systems. By 1901 there were 14 exchanges in United States operated based on CB systems [76]. In following years CB systems were installed at Hague, Netherlands in 1903, Kyoto exchange in Japan (1903) and exchange serving 60,000 subscribers at Moscow (1910). During 1905, first automatic exchange operated entirely on common battery system was opened at South Bend, Illinois.

## 12. Improvements for Successive Strowger Exchanges

The various mechanisms were designed to improve the performance of switches. The first design was piano wire. The design went in problem and inventors were forced back to follow the original design for improvements.

In 1893, Strowger switch was exhibited in a World Fair held at Chicago pushing this product for more and more commercial use [110]. At the same time, during 1893 itself, automatic connection release concept was introduced by A. E. Keith. This led to a present day hook switch concept. During beginning of 1894, Frank A. Lunquist and Erickson brothers (John and Charles) joined the services of Strowger company to work with Keith to work for the improvements of Strowger switch that was capable of both a rotary and a longitudinal movement called as Piano wire design [110]. This type of design was installed at La Porte, Indiana in the year 1894, and at the same time, a simple concept of indication of busy signal was introduced. The free line was indicated by ringing the bells at both the ends, while line busy status is indicated by no bell signal. These installations also used automatic connection release

invented by Keith. The piano wire design could not prove to be popular.

The earlier piano wire type of switches was replaced by this improved design in the exchange at La Porte, Indiana. It still required 5 lines for interconnecting telephone. During 1895, Keith and Erickson brothers filed a patent application on the basis of improved design based on Strowger's work, that resembles to modern step by step switch and patent was granted to them in 1899. These types of arrangements continued in exchanges till the 1900.

### 12.1. Rotary Dial Mechanism

Till 1896, in Strowger system, selection of the digits was done by a complicated system involving push button switches involving five wire telephone interfaces. Rotary dial was facilitator for automatic selection telephone line leading to destination telephone or listener's telephone. Many people worked toward success of automatic telephone exchanges. M. D. Connolly of Philadelphia, T. A. Connolly of Washington DC and T. J. of Pittsburgh worked jointly for automatic telephone exchanges for dial telephones and first telephone patent was awarded to them for their exchange. Many patents for dial telephone switching were issued between 1879 to 1900. However only Strowger patent from March 10, 1891 resulted in successful commercial automatic system [118].

Later on, the system of timed pulse (TP) dialing was invented by Keith and Erickson brothers using a rotary dial in 1895 [119]. The patent was filed by them on August 20, 1896 and was granted on January 11, 1898. This work replaced push buttons by a rotary dial having digits 1 to 9 and X impregnated on dial base. While holds on the finger plate aligned with digits is used for dialing that particular digit producing the pulses equal to that digit. Most modern rotary dials had holes instead of holds, and now we have push buttons representing 0-9 digits and many other functions. The rotating wheel was a simple make and break arrangement to produce the pulses related to a num-

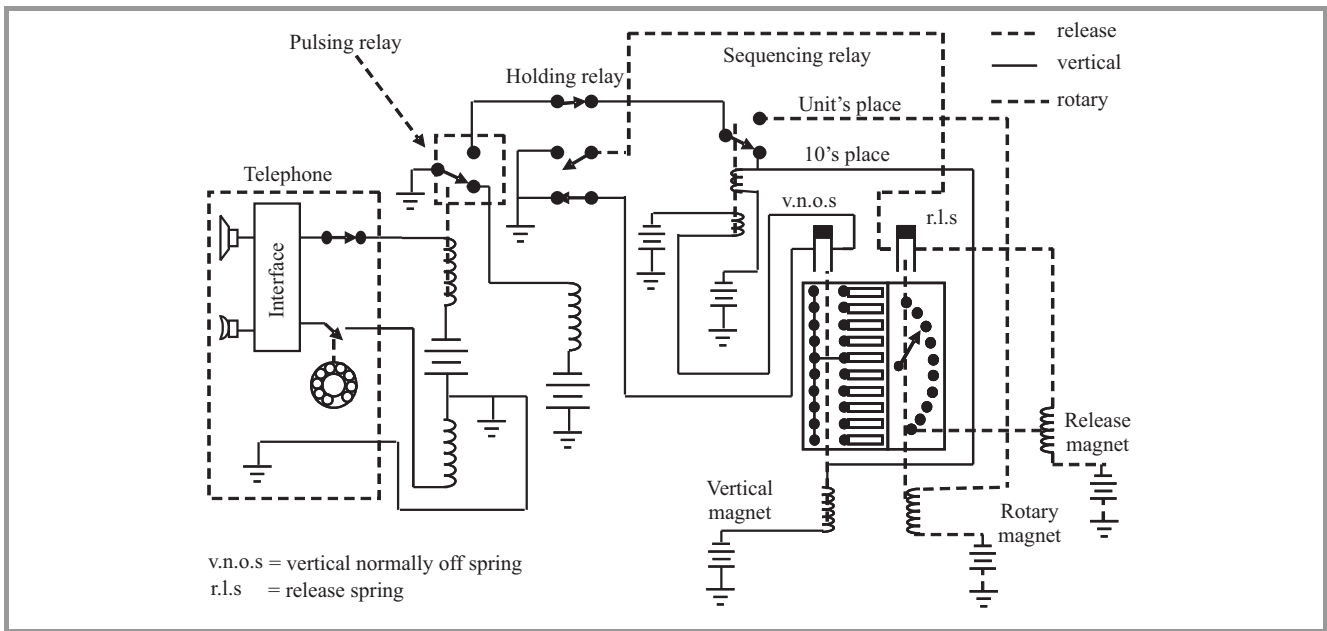

Fig. 38. Three-wire interface between rotary dial telephone and telephone office.

ber dialed. These pulses took over the control of operations at central office. The first rotary telephone dial used during 1896.

The pulses produced by rotary dial are transmitted over 2 wire interface [120], [121]. Telephone instrument, consists of microphone, speaker, hybrid converter interface, dial and hook switch. The hook switch represents two conditions called on-hook (idle condition) and off-hook (telephone is connected to telephone company office). When cradle is lifted, hook switch makes physical connection between telephone instrument and central office allowing central office battery to get connected to telephone instrument forming a current loop between CO to telephone instrument making telephone instrument ready for dialing required telephone. The telephone connection to telephone company's office is shown in Fig. 38.

When cradle is lifted, telephone instrument at customer side is powered by a battery at central office and telephone instrument at customer is activated to complete local loop leading to the customer. These happenings allows customer to dial the destination telephone number. When first digit is dialed (digit at 10's place), pulses produced by pulsing relay are carried forward through holding relay and sequencing relay for the purpose of moving vertical contacts of bisector switch. The contacts are moved till desired vertical position is attained. At this point, sequencing relay shifts its position to unit's place allowing next digit to be dialed for activation of rotary magnet to select a desired contact. When contact is selected, conversation to selected phone takes place and when conversation is over caller releases the line, this also releases holding relay, release of holding relay operates release magnet, which internally rotates shaft to home position and wiper falls down to lowest position due to gravity.

### 13. 1000 Line Augusta Exchange

Also during 1896, Keith and Erickson brothers started working towards 1000 line telephone system based on call transfer concept or trunking (or selector trunking) for multiplying subscriber lines at each switch. Using trunking concepts, large number of users can be served using smaller number of communication paths. Various COs at various places are connected using trunk lines (pairs of copper wires). A selector trunking system of 1000 lines based

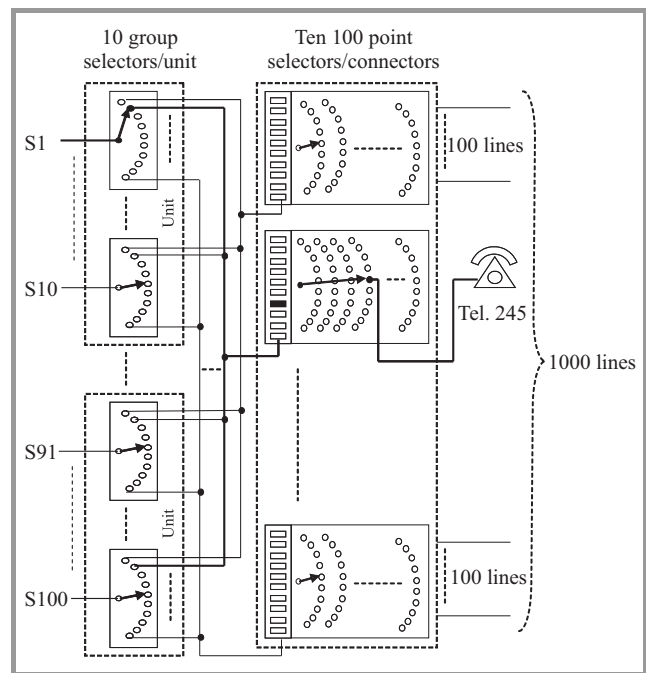

Fig. 39. Trunking scheme employed at Augusta, Georgia, USA, during 1897.



on dialing system developed by Keith and Erickson. The system of 400 lines was installed at Augusta, Georgia in 1897 [76]. Individual subscriber has his own group selector. Ten subscribers had ten group selectors. A primary stage (first selector) gave the access to a group of 100 subscribers while secondary stage (connectors) has 100 point selectors (concentration ratio of 1:10). The basic principles employed in exchange at Augusta are shown in Fig. 39.

In above mentioned scheme, internal blocking occurred when two subscribers in the same group, calling the subscriber belonging to same hundred group leading to impractical systems. Owing to these difficulties, Keith improved the design (Fig. 40) and first selectors near subscriber were modified to include 1 out of 10 search

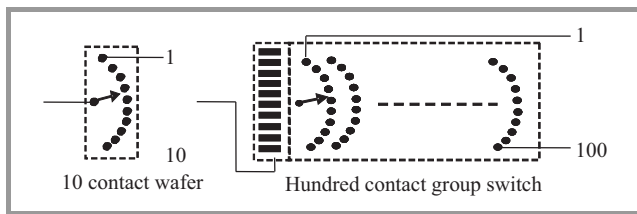

Fig. 40. Improvement in selector switches.

for finding idle line to approach to next selector that is connector [76]. With this modification, group selector switches no longer considered to be a set of ten but considered to be a set of 100. This arrangement drastically reduced number of selector switches required in the exchange.

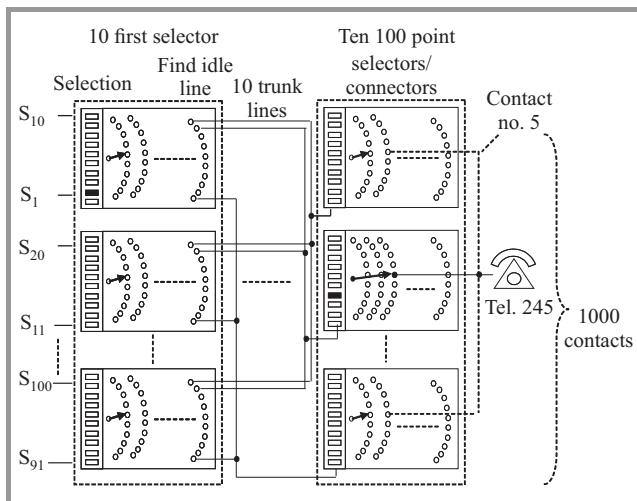

Fig. 41. Improved Strowger exchange at Augusta, Georgia, USA.

The modified Strowger exchange based on above modifications at Augusta is shown in Fig. 41.

### 14. Telephone Interface

In 1896, push buttons in Augusta exchange, were replaced by large rotary dial having three wire interface

(2 wires and a ground), while large dial (which was invented in 1907) with two wire interface without ground was introduced at Pontiac, Illinois in 1908 [122]. In the same year, a small rotary dial using 2 wire interface without ground was introduced at Lansing, Michigan. These two wires were used for sending dialing pulses, supplying power to subscribers and transmission of speech signals. The basic principle of two wire interface was based on the bridge circuits consisting of four impedances connected within the arms of the square leading to four junction points A, B, C and D. The pairs of opposite ends (A, C) and (B, D) are used for connecting the source (mic) and receiver (speaker) respectively as shown in Fig. 42.

Ideal DC feeding circuit is required to ride voice signal on the DC current of higher magnitude, which is blocked at the voice signal receiver to separate the voice signal from the composite signal (DC and voice signal) serving the purpose of raising the energy of signal to be transmitted on the telephone lines. The ideal DC feeding circuit is well described in a series of European standards called EN 300001 v1.5.1 [123], and is shown in Fig. 43.

The feeder voltage values differ from country to country and range from minimum of 24 V (Czech Republic and Norway) to maximum of 104 V (France). However in most of the countries feeder voltage is 48 V.

The tolerable range of variation of values of feeder current, inductors, resistances and capacitances are as follows. Feeder voltage variation  $\Delta V_f$ : 15 to 64 V while in loop condition  $\Delta V_f \leq 64$  V. Feeder current variation  $\Delta I_f$ : 1 to 60 mA, while loop condition  $\Delta I_f = 1$  to 60 mA while loop feeder resistance values  $\Delta R_f$ : depends on  $V_f$  and  $I_f$  values (300 to 5000  $\Omega$ ). The feeder components such as  $C_f$  and  $L_f$  affect ac signal performance and must meet all requirements of signal of interest. Usually  $C_f \geq 20 \mu F$  and  $L_f \geq 5$  H.

The popular feeder voltages are 48 and 60 V. The feeder voltage of 48 V (-10% , +20%) requires bridge resistance of 800  $\Omega$  while for feeder voltage of 60 V (10%) requires bridge resistance of 1000  $\Omega$ .

### 15. 1000 Trunk Line Automatic Strowger Exchange

During 1897, engineers at Strowger Automatic Telephone Exchange Company started working on problem of 1000 trunk line automatic exchange in which selector have several sets of contacts in each row, leading to several connectors that can serve a group of 100 lines. In this project the idle trunk line was automatically selected as subscriber goes on dialing and patent was awarded to Frank A. Lundquist and first practical automatic exchange was put in service on November 1900 at New Belford, Mass, having its 4000 subscribers. In 1901, name of Strowger Automatic Telephone Exchange

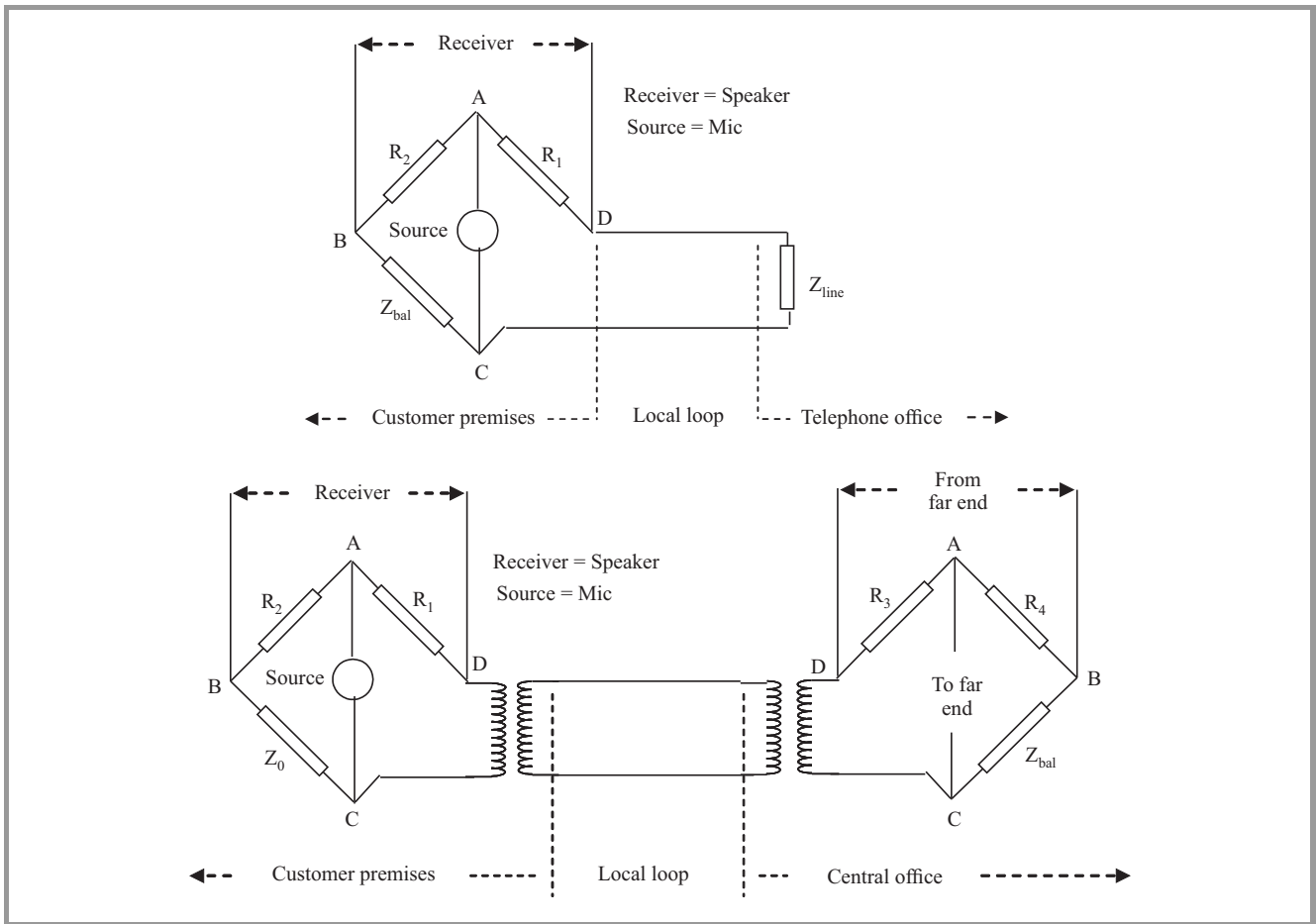

Fig. 42. Basic bridge configurations used in 2 wire local loop.

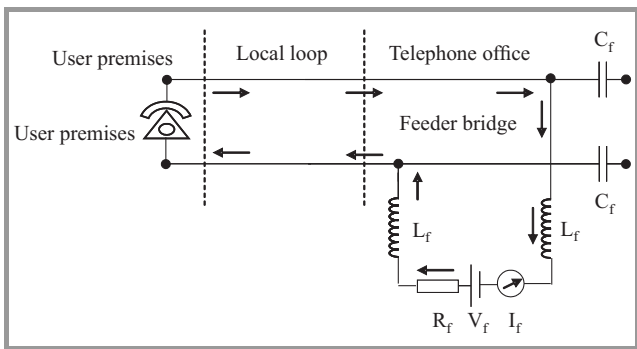

Fig. 43. Ideal DC feeding bridge.

Company was changed to Automatic Electric Company (Autelco) to completely exploit the Strowger system under the Keith technical leadership. In new company, engineering staff consisted A. E. Keith, T. G. Martin, J. Erickson, C. J. Erickson and E. C. Dickenson. The similar exchange as that of earlier, having capacity of 10,000 lines was installed at Chicago in 1903 [37], [76]. During following years, to cater number of customer/subscriber lines and to reduce number of group selectors, a principle of preselection was introduced at exchanges installed at Delaware.

15.1. Ten Thousand Line Automatic Strowger Exchanges

In automatic exchanges, the three configurations of Strowger relays (Fig. 44) called preselector switches for

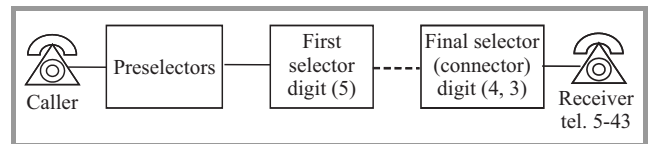

Fig. 44. General principle of routing in step-by-step automatic Strowger exchange.

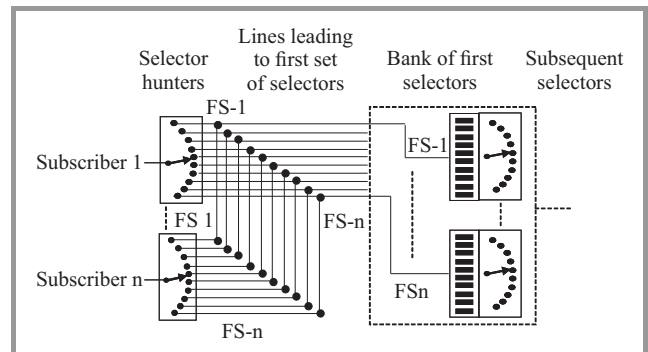

Fig. 45. Hunting scheme using uniselector switches.

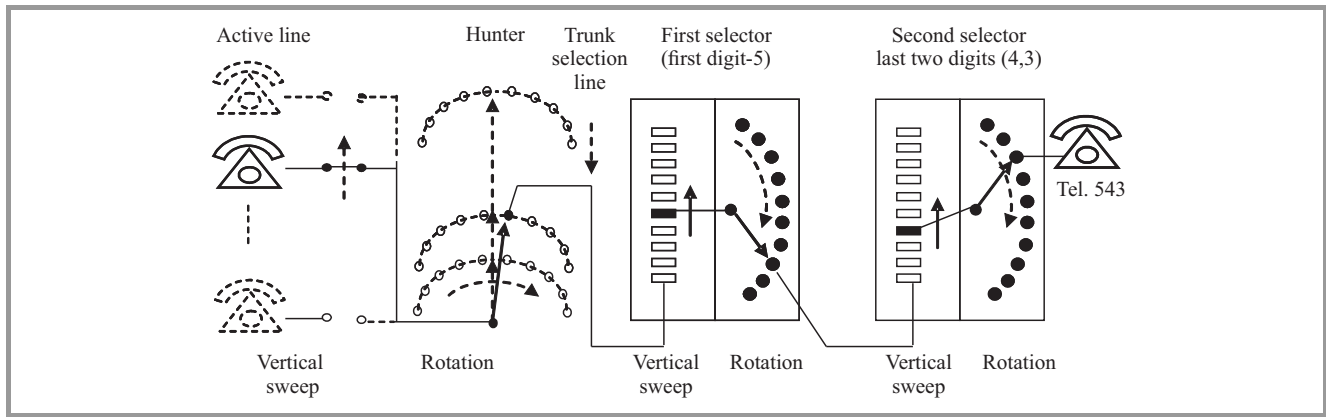

Fig. 46. Hunting scheme using biselector switch.

connecting to subscribers, two biselector switches for step by step routing, and connector switches for connecting destination telephones were used.

The preselectors are used in the form of two configurations called as hunters or line finders. The hunters or line finders are front relay selectors used for connecting the caller's end, while there can be number of selectors depending on number of digits assigned to a telephone number in the system and finally using connector relay, receiving telephone is connected. For example, is system has three digit telephone numbers and if destination telephone number is 5643 is to be contacted, the hunter relay continuously sweeps vertically across all the incoming lines till active line (off-hook) is located, dial tone tells subscriber that he may start dialing and also relay rotates repeatedly till free trunk line is found. After free trunk line is found, this free trunk line connects next relay (selector) that handles the first digit 5 of telephone number. At this point, when first digit 5 is dialed, contact is moved to 5th deck of contacts, when relay rotates to find next switch in chain. When next digit of destination telephone number 6 is dialed, contact is moved to 6th deck of contacts when relay rotates to find next switch in chain, which acts a connector which uses last two digits (4 and 3) of telephone number for connecting destination telephone. Digit 4 points to a 4th deck of contacts and rotational motion selects 3rd contact to establish the contact between source and destination telephones.

15.2. Preselector Schemes

Caller side interface is implemented using two types of approaches called hunter and line finder schemes [112], [124], [125].

In hunter based configuration, path search is initiated by the active subscriber line or a caller has an access to 23 or 24 first selectors through his own hunter selector. Hunter based scheme using uniselector switches is shown in Fig. 45.

In this case, each subscriber is connected to one uniselector switch representing a configuration such that number of uniselectors is equal to number of subscribers. In

this scheme, when subscriber lifts his telephone for calling, hunter gets activated, and wiper steps continuously till first selector (FS) group can be approached. The first selector switch then sends a dial tone to the active subscriber through selector hunter indicating that subscriber can call the party of his interest.

The another scheme can be implemented using single biselector switch for a group of 10 subscribers, in which active subscriber is located vertical motion of switch, while first group selector switches are approached using continuous rotational movement of selected wiper. The example of hunter scheme using biselector is shown in Fig. 46.

The main difference in hunting schemes and line finding is that in line finding scheme, first selector has direct approach to line finder, while in hunting scheme active subscriber line is responsible to locate idle first selector.

In line finder, all the subscriber lines are terminated to all the line finder connections, indicating that every subscriber is approachable through every line finder switch, which is evident from line finder scheme is shown in Fig. 47. A line from every finder is extended to its corresponding switch in a bank of first selector switches.

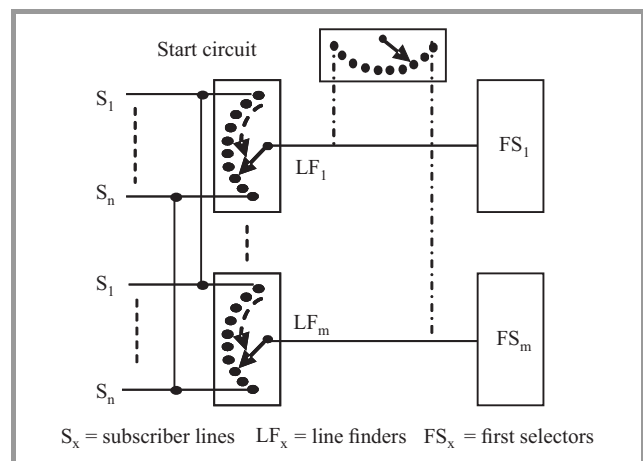

Fig. 47. Line finder scheme.

Line finder mechanism continuously scans the incoming subscriber lines to see that there is any active line approach-

ing from the subscribers and once active line is located by the line finder, the existing connection between line finder and first selector is stated using start circuit. In short, in hunting scheme, path to first selector is located and connected, while line finding schemes existing path to first selector is activated once active line is located.

### 15.3. Ten Thousand Line Automatic Strowger Exchange Scheme

10,000 line automatic exchange schemes using above concepts were implemented, using preselectors consisting of line finders, hunters, selector switches and connectors [37], [112], [125], [126]. The scheme is shown in Fig. 48.

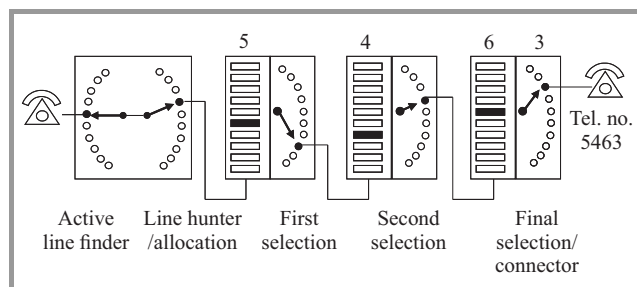

Fig. 48. 10,000 line automatic exchange configuration.

In following years, many important automatic systems were installed at Lincoln, Dayton, Columbus, Tampa, Grand Rapids, St Paul, Sioux, Jackson Ville, Buffalo, Spokane, Portland, Omaha, Edmonton, Regina in the USA, and Saskatoon in Canada, Havana, Cuba and most of the Australia.

## 16. After the Expiration of Bell's Patent in 1894

In 1894, Bell's patent on telephone expired, but due to valuable services rendered by company, continued to be in focus. Till 17 years of patent protection, Bell's and its associated companies enjoyed monopoly over the telephone services. After this point of expiration of Bell's patent, various independent (non-Bell companies) were free to offer telephone services without paying any license fees to Bell. Just year after expiration (1895), 87 independent companies entered in the telephone business [127]. In 1902, throughout US, 40,000 companies were in the telephone business. In 1907, the business of share independents grew to 51% while AT&T share was dropped to 49% from nearly 94% in 1894.

## 17. Integrated Transmitter and Receiver Handset

During 1904, Bell developed a handset that integrated both transmitter and receiver for human convenience. However

it was made available to subscriber during 1927 due to its cost and desk set were used till 1927. The phones having integrated transmitter and receiver were called French phone.

## 18. Establishment of Bell Telephone Laboratories

In 1907, Vail N. Theodore was again asked to return as president of AT&T. During his term, he developed guiding principles for the company in terms of philosophy, strategy and organizational structure. During 1908 he took nationwide advertising campaign with a slogan "One system, one policy, universal service". AT&T being a parent company of Bell System put an end to harassment to independent telephone companies. It also perused the policy of standardization. The terms of collaboration made friendly for attracting independent telephone companies. During 1913, AT&T settles first federal antitrust suit called Kingsbury (AT&T vice president was Nathan Kingsbury) commitment, establishing AT&T as Government approved monopoly. It also allowed non competing independent telephone companies to connect AT&T network and no more taking over of independent telephone companies. In 1915, AT&T's long distance service reached San Francisco. In June 1919, Vail N. Theodore retired as president and became the chairman of board. During 1925 AT&T establishes Bell Telephone Laboratories as its research and development subsidiary, and its systematic contributions and policies were awarded in terms rise in revenue share to 79% in the year 1934.

## 19. An Era of Automatic Telephone Exchanges

After introduction of automatic telephone exchanges, in 1910, it was an era of automatic telephone exchanges and automatic telephone started superseding manual telephones [128] and US observed highest telephone penetration rate numbering 7 million subscribers as compared to Russia having 155,000 subscribers. This also made telephone numbering complicated due to highest growth leading to millions of subscribers. This demanded large number of digits representing telephone numbers. In 1930, New York introduced three literals and four numerals to represent telephone number (LLL-NNNN) and till mid 1960's London and Paris followed the same rule to represent telephone number.

The wide spread of telecommunication was led to united approach for solving the problems of telecommunication workers. During 1911, an international conference of postal, telegraph and telephone workers was held in Paris established federation of International Post, Telegraph and Telephone (IPTT). However, its formal launch was delayed until the 1920, when congress meet was held in Milan and



it was registered in the form of its present form Posts, Telegraph and Telephones International (PTTI). The headquarter was located in Vienna and remained at Vienna till 1933. This secretariat was transferred to Bern, Brussels and finally to Geneva in 1969.

## 20. Introduction of Cables Services for Telephone Lines

Early long distance telephone lines were open wires, use of cables started when loaded cables became available [129]. In 1902, a telephone using loaded cable was laid between New York to Newark covering the distance of 11 miles (17.7 km), while in 1906 loaded cable from New York to New Heaven (79 miles, 127 km) and New York to Philadelphia (89 miles, 143 km) were installed. The loads of these lines were in the form of coils of 250 mH and wires were of 14 AWG diameter (2 mm<sup>2</sup>).

## 21. Underground Cable Services and Vacuum Tube Amplifiers

The large numbers of telephone lines on the poles were posing lot of hurdles for civic administrations forcing them to make local ordinances in many town and cities called for elimination of such lines from main streets, forcing a way for placing cables underground [130]. In the winter of 1910 work moved for placing underground telephone cables between Washington and Boston. First long distance underground cable service between Boston to Washington via New York was started in the year 1914. To make up for signal loss, use of loading coils was evident. The telephone engineers extended long distance service westward from the Atlantic seaboard to Denver by 1911 and to Salt Lake City by 1913. More effective means, better than loading coils were invented by Lee De Forest in the form of 3 element "vacuum tube" or "Audion" (October 30, 1912), which could amplify the signals for long distance transmission to make up for signal losses. The use of such amplifiers periodically along the telephone lines were known as repeaters. AT&T brought the patent rights from De Forest. During 1913, AT&T tested the technology of vacuum tube amplifiers on a long distance network. On June 27, 1914 the company completed the line from Denver to Wendover, Utah and also on January 25, 1915, AT&T opened a first coast to coast transcontinental telephone line from San Francisco to New York (3500 miles, 5632 km) and it was the first transcontinental line using such amplifiers [131].

## 22. Transatlantic Telephone Services

During 1840–1850, for telegraphy, marine cables with gutta-percha insulation were laid in rivers and harbors [132]. In 1851, a underwater electric cable telegraph link was laid between England and France, and later on

European countries, USA and Canada were connected together. The first transatlantic cable was laid in 1858 between Ireland and Newfoundland, which was hardly operated for a 26 days and failed after that [132], [133]. The failed transatlantic cable was then replaced by new transatlantic cable in 1866. Yet another underwater cable service went operation in 1884 from San Francisco to Oakland. The transatlantic cable service remained problematic and hence, the later part of long distance communication was dominated by radio transmission.

During 1901, wireless link between Cornwall and Newfoundland covering a distance of 2112 miles (3400 km) was established [134]. Similarly during 1904 and 1908 transmission of photograph between Nuremberg and Munich as well as radio telephone link between Paris and Brittany (west side area of France) respectively.

During 1915, Bell System (AT&T being parent company of Bell system) engineers were able to achieve voice transmission across the Atlantic connecting Virginia and Paris. A year later, two way communication was held using ship at sea. During 1926, there was first successful transatlantic two way communication and finally a commercial service using two radio stations was started between New York and London on January 1927. The year 1935, was a year of celebration for AT&T marked by a successful "Around the globe" communication by president and vice presidents of AT&T named W. S. Gifford and T. Miller respectively.

The global communication using submarine cable began on September, 1956 when first transatlantic under sea telephone system (TAT-1) from Clarenville, Newfoundland to Oban, Scotland went in to service [135]. It was the result of effort put forward by AT&T Bell Laboratories and British post office that provided reliable service with relatively fragile components in hostile environment. The two cables were used for each direction stretching over the distance of 1950 nautical miles and each cable had fifty one repeaters providing a 65 dB gain with 144 kHz bandwidth. TAT-1 provided 29 telephone circuits between New York and London. This system was operational till 1978.

## 23. Development of Condenser Microphone

Meanwhile, during 1916, E. C. Wentz at Bell Labs developed the condenser microphone [136]–[138]. This invention enabled use of vacuum tube amplifiers. The patent of condenser microphone was filed on December 20, 1916. The device was constructed using two parallel plates forming a capacitor whose value changes due to variation of distance between them as a result of sound pressure striking on one of the thin plate in the form of diaphragm. The diaphragm was constructed using steel having thickness of 0.002 inches (50  $\mu\text{m}$ ) which was placed near to another plate maintaining the distance of 0.001 inch (25.4  $\mu\text{m}$ ) containing an air gap between them. In idle condition, capacitor having its value as  $C_0$  is changed to

$C_1 = C_0 \pm \Delta C$  due to dynamic pressure exerted by the sound waves. The change in capacitor value is responsible for generating a voltage proportional to  $C_1/C_0$  converting sound vibrations to an electrical signal.

## 24. Bell System’s First Automatic Exchange

Bell System did not install their first automatic exchange until 1919 in Norfolk, VA. The one feature which was provided with the first Bell System exchange in Norfolk was dial tone [122]. Dial tone was first introduced by Siemens in Germany in the year 1908 but it took nearly nine years to get it popularized. Bell System was first to make it commercially popular in its above mentioned Norfolk exchange.

## 25. Crossbar Telephone Exchanges

Idea of crossbar exchange was conceived as early as 1901 by Homer J. Roberts, but it took 16 years to be practical [76], [140]–[142]. The pioneering efforts by John G. Roberts and John N. Reynolds (1913), engineer with Western Electric, USA was responsible for patenting the practical crossbar system in 1916 but was never exploited, while Gotthilf A. Betulander (engineer in Swedish administration called Televerket) and Nils G. Palmgren were responsible for designing first satisfactory cross bar mechanism. Betulander was responsible for separating selection circuits from connecting circuits. The selection circuit consisted of user dial and devices for finding the called subscriber line. The logic of separation is shown in Fig. 49.

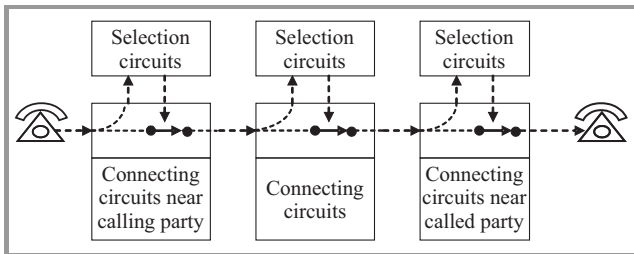

Fig. 49. Separation of selection circuits and connecting circuits (logic of Betulander).

That selection circuits are used only during the process of connection establishment and connection release. As digits related to destination telephone number are dialed one by one, the connections are successively established along the path leading to destination telephone and remain active only for short duration (selection time) till connection is established. Once connection is established, selection circuits have no role to play. The connected path is then used for voice communication between calling and called parties. The connecting circuits were in the form horizontal vertical lines in which cross points do represent a matrix of switches.

The basic principle of cross bar switch is shown in Fig. 50. To connect input line to output line, the switch at cross point is activated. Using such configurations any input line can be connected to any output line. Main advantage of cross bar switching is to eliminate sliding contacts in the earlier systems and was based entirely on the extensive use of relays. This design used one reed relay at each cross point leading to expensive design. This design was modified later on to use fewer relays. In modified design, single relays were used for each column and row, minimizing the number of relays in the design.

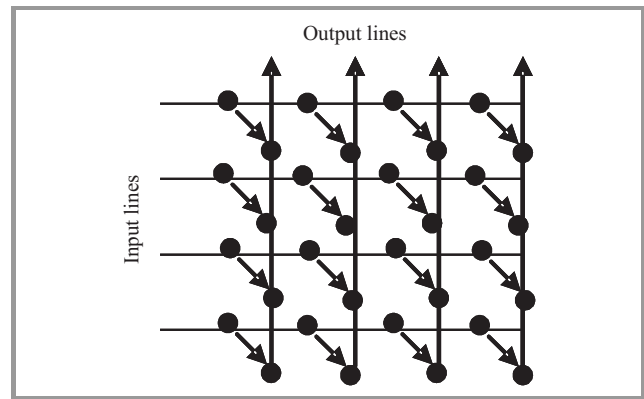

Fig. 50. Basic principle cross bar switch.

### 25.1. Foundations of Crossbar Switches

The basic foundation of crossbar switch was laid in a small company of Betulander called Nya Autotelefon Betulander. This company worked on registers controlled automatic telephone switches based on relays leading to a patent in the year 1912. The first 100 line subscriber demonstration exchange based on Betulander’s all relay system was exhibited in Marconi House in London during 1913. Televerket kept rights for such a system in Sweden, while overseas right was transferred to an another English firm called The Relay Automatic, which installed exchanges at London (in 1916), Lancs (in 1922), India and France [143]. In 1926, these switches were used initially in rural exchange at Sundsvall. By 1944, around 1100 exchanges were installed in Sweden.

In 1919, due to order placed by Televerket to Betulander for supply of test station using such system, Betulander and Palmgren started working on new selector design based on crossbar switch using fewer relays than earlier design [142]. During 1919, Nya Autotelefon Betulander was acquired by Ericsson. The Ericsson started marketing of this switch. After sale of his company, Betulander resumed his work at Televerket. One year later, in 1920, Televerket selected 500 switches (sometimes referred as work horse) for automated equipment in Stockholm and Gothenburg. The first station with switch 500 was opened in 1923. The idea of 500 switching system was conceived by the Axel Hultman, director of Televerket, Swedish Post, telegraph and Telephones (PTT), Stockholm. The success of these Swedish

switches received worldwide attention during 1920s. During 1926, the work of Betulander and Palmgren resulted in a country's first experimental exchange in Sweden using crossbar switching [144].

**25.2. Crossbar Link Trunking**

Using switch matrices of different size compression of expansion of number of lines can be for example, if switch matrix of 3x4 (3 inputs and 4 outputs) is used, 3 to 4 line expansion is achieved. The 9 line to 16 line expansion is shown in the Fig. 51.

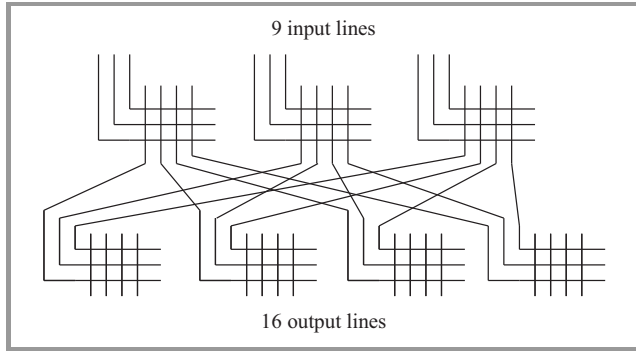

Fig. 51. Crossbar link trunking principle.

**25.3. Spread of Crossbar Exchanges in United States**

The Bell Labs Engineers visited Sweden to study the economics and traffic characteristics of these switches in the year 1930. Bell Labs ordered few switches for analysis and worked secretly for their own developments which led to the development of switch called Xbar #1 (developed by Western Electric). These developments by Bell Labs were not exposed till 1937 and finally Xbar #1 was first used in an installation at Troy Avenue central office, Brooklyn, NY in 1938, which was closely followed by East 30 street Manhattan. The crossbar switch designed by Bell Labs was similar to Swedish design in which Bell Labs used link connection principle with resistor and mark control of Betulander and Palmgren. The faster developments took place during World War II and Xbar #1 was modified to more advanced Xbar #5 switch, which became key element in crossbar exchanges during 1950s and 1960s. The Xbar #5 switch existed till 1969 after that its production was stopped. The developments of Xbar #5 was significant from the angle of handling DTMF tone dialing, which was introduced during early 1962. Xbar #1 and Xbar #5 were the switches to be used in local central offices. Xbar #1 switch was used in early crossbar systems while Xbar #5 switch was used in latter period (during 1962).

During early crossbar exchange era (late 1930s), it was realized that Xbar #1 was not sufficient to handle short haul (regional) and long haul (toll) calling. This resulted in a development of tandem crossbar switch (XBT) by Western Electric in 1941. XBTs were mainly used for regional or city wide tandem switch. In early day's context, XBT

served the purpose of long haul switches. Further, during 1940s it was realized that even XBT was not enough to serve the purpose of long haul communication that gave a way for development of Xbar #4 switch which was installed at Philadelphia PA in 1943. During 1950s Xbar #4 switch was further modified (called Xbar #4A) to accommodate dynamic routing rather than hardwired routing and were in use from 1953 to 1968.

**25.4. Modifications in Exchanges Due to Introduction of Crossbar Switches**

The early telephone exchanges used the step by step (SXS) switching, in which, progressive connections were made as digits are dialed. Invention of crossbar switches allowed switching over from progressive control to common control. The common control systems are divided in to three categories such as trunk supervision, routing control and data storage control. In common control, the dialed digits are first stored in a register in the form of a complete telephone number which is then analyzed and acted upon by a marker. Marker is a hardware processor used in analysis of a call and once call is setup, register and markers are freed to handle other call setups [145]. The markers are treated as brain in the crossbar exchange systems. The crossbar matrix is controlled by common control. The control signals from transmission lines are detected and used for the managing the connections between input and output lines of crossbar matrix. Modern signaling systems emulate common control signaling principles.

**25.5. Mark and Register Controlled Crossbar Exchange**

Typical crossbar trunking exchange consists of line units at sender's and receiver's ends, group units, registers and markers as shown in Fig. 52.

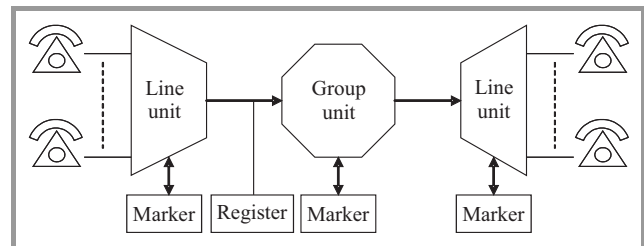

Fig. 52. Trunking crossbar exchange.

When telephone number is dialed, dialed digits are stored in register, and once complete number is dialed, marker analyzes the dialed number and connection is made through group unit to a line unit related to destination telephone. Markers at input and output line units analyze the input active lines and destination telephone lines for connection. As on today, there are three generations of switching exchanges called as step by step exchanges, cross bar exchanges (common control exchanges) and processor controlled exchanges or recent digital exchanges. The Strowger exchanges are

the classic examples of step by step exchanges in which connections are made progressively and step by step to make connections to far end. In crossbar exchanges, the number of relays got increased drastically, which really required the miniaturization of these relays (reed relays) that allowed number of simultaneous connections. The crossbar exchanges being second generation, demanded more elaborative arrangements exchanges in the form of various classes of exchanges.

## 26. Introduction of Toll Switching Plans by AT&T

With the intension of creating hierarchical telecommunication network in USA, in 1929, AT&T implemented its general toll switching plan. As per this plan, AT&T set up a national network by connecting its eight regional centers. The regional centers were accessible to 2000 toll offices throughout the country through more than 140 primary centers (approximately one primary center in each state). The hierarchical arrangement of various switching centers is shown in Fig. 53. The additional direct connections were provided to various heavily loaded traffic centers for smooth functioning of total system.

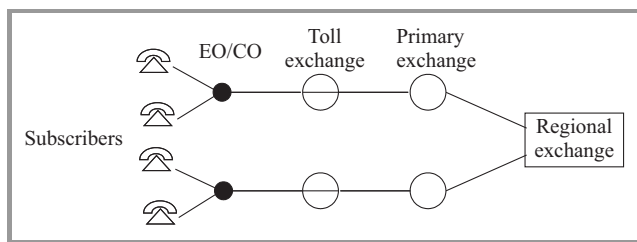

Fig. 53. AT&T's hierarchical switching plan.

## 27. Analog Voice Communication Before Digitization of Voice

The basic analog telephone interface circuit (Fig. 54) describes how analog telephone is interfaced to telephone line.

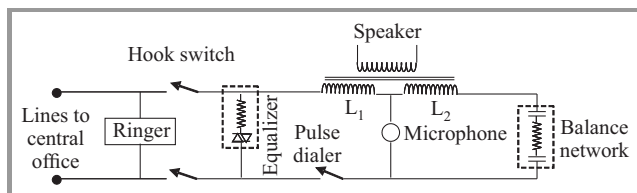

Fig. 54. Analog telephone interface.

The interface circuit shown is a simple bridge circuit that can be compared with a circuit shown in Fig. 42 where  $R_1 \equiv L_1$ ,  $R_2 \equiv L_2$ ,  $Z \equiv$  balance network,  $Z_{line} \equiv$  equalizer.

## 28. Logic of End to End Connection Management Through Various Exchanges

To have a telephone conversation, first connection is established and once connection is established, the users at both ends can talk, is called as connection oriented technology. Automatic exchanges allows establishment of connection between two end parties to have voice conversation. The telephone call consists of establishment of connection between two end parties, voice conversation, breaking of connection. Connection and disconnection between end parties is called as a signaling part, while actual voice service availed by user is a user service part. The automatic exchanges enable above mentioned services.

When hand set is lifted, power supply from central office gets connected to the phone and dial tone can be heard indicating phone is ready for dialing. Now the telephone number of other end could be dialed. If other telephone is busy then the busy tone is heard otherwise ring goes to that end indicating phone is connected. If handset of other end is lifted then a talk starts and after talk is over then handsets are put in on hook position.

### 28.1. Both Ends Are Idle

When telephones at both the ends are on-hook, indicates both ends are idle. This condition is expressed in the form of Fig. 55a.

### 28.2. Telephone at Caller End Lifted

When customer/caller decides to make call, he lifts from handset from cradle, closes the loop between the CO switch and the telephone at caller's end that allows current to flow in local loop at caller's end. CO switch detects this current flow and transmits a dial tone (350 and 440 Hz tones played continuously) to the telephone set of caller (Fig. 55b).

### 28.3. Dialing Phase

The dialing phase allows the caller to enter a telephone number at another location. This generates pulses or a touch-tone (push-button) phone that generates tones. Soon after first digit is dialed, dial tone is removed. These telephones use two different types of address signaling in order to notify the telephone company where a subscriber calls: dual tone multi frequency (DTMF) dialing and pulse dialing. These pulses or tones are transmitted to the CO switch across a two-wire twisted-pair cable (tip and ring lines), see Fig. 55c.

### 28.4. Switching Phase

In the switching phase, the CO switch translates the pulses or tones into a port address that connects to the telephone set of the called party. This connection could go directly



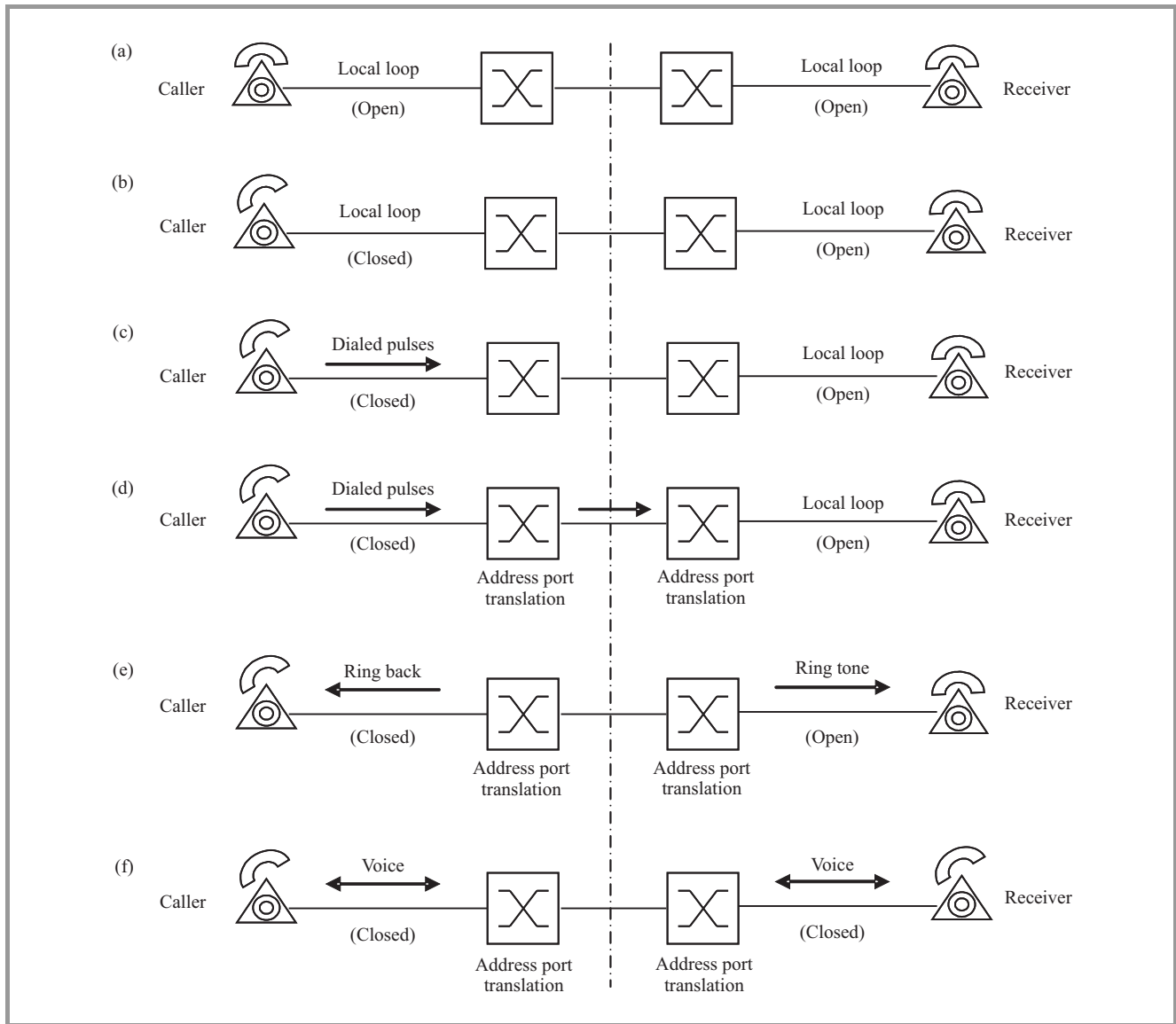

Fig. 55. Voice communication between caller and called party.

to the requested telephone set (for local calls) or go through another switch or several switches (for long distance calls) before it reach its final destination (Fig. 55d).

**28.5. Ringing Phase**

Once the CO switch connects to the called line, the switch sends a 20 Hz, 90 V signal to this line. This signal rings the phone of the called party. While ringing the phone of the called party (Fig. 55e), the CO switch sends an audible ring-back tone to the caller. This ring-back lets the caller know that ringing occurs at the called party. The CO switch transmits 440 and 480 Hz tones to the caller phone in order to generate a ring-back. These tones are played for a specific on time and off time. If the called party phone is busy, the CO switch sends a busy signal to the caller. This busy signal consists of 480 and 620 Hz tones. Figure 55f shows the talking phase.

**28.6. Talking Phase**

In the talking phase, the called party hears the phone ringing and decides to answer. As soon as the called party lifts the handset, an off-hook phase starts again, this time on the opposite end of the network. The local loop is closed on the called party side, so current starts to flow to the CO switch. This switch detects current flow and completes the voice connection back to the calling party phone. Now, voice communication can start between both ends of this connection (Fig. 55f).

**Acknowledgements**

Author wishes to acknowledge the management of Trinity College of Engineering and Research, Pune for encouragement in taking up such self styled work for the benefit of students to know how interesting are developments of antique telephone systems got with respect to historical

timelines. I also acknowledge my colleagues of Trinity College of Engineering and Research, Pune, for very fruitful suggestions and discussions time to time. I also acknowledge the critical review by Dr. G. N. Acharya, former director, Central Electronics Engineering Research (CEERI), Pilani, India.

## References

- [1] F. M. Sorrentino and J. Kruse, *The Review of Italian American Studies*. Lanham, Maryland, USA: Lexington Books, 2000.
- [2] G. E. Schiavo, *Antonio Meucci Inventor of the Telephone*. New York: The Vigo Press, 1958, pp. 171–181.
- [3] Andrea Sandre, *Italy@150 – Celebrating the Friendship Between Italy and the United States*, published by Embassy of Italy in Washington (DC), 2011.
- [4] B. Catania, “Il governo degli stati uniti contro Alexander Graham Bell”, *Supplemento di AEI Automazione Energia Informazione*, no. 10, 1999 (in Italian).
- [5] B. Catania, “Un documento inedito rivaluta l’opera di Antonio Meucci”, *AEI – Automazione, Energia, Informazione*, vol. 82, no. 2, 1995, pp. 32–40 (in Italian).
- [6] B. Catania, “Antonio Meucci Revisited”, *Antenna*, Newsletter of the Mercurians, in the Society for the History of Technology, vol. 9, no. 1, pp. 4–5, 1996.
- [7] M. D. Fagen, *A History of Engineering and Science in the Bell System: The Early Years (1875–1925)*. New York: Harper and Row Publishers, 1975.
- [8] F. Winwar, “Il Monumento di Staten Island: Meucci, Garibaldi e il telefono”, *Poste e Telecomunicazioni*, Apr. 1958, p. 307 (in Italian).
- [9] C. Bourseul, “Transmission électrique de la parole”, *L’Illustration*, Aug. 26, 1854 (in French).
- [10] R. Camboulives, “Un Occitan d’adoption: Charles Bourseul, inventeur du téléphone”, communication faite à l’Académie des sciences, inscriptions et Belles-lettres de Toulouse dans sa séance du 8 novembre 1978 (in French).
- [11] S. P. Thompson, *Philipp Reis: Inventor of the Telephone*. New York: Arno Press, 1974.
- [12] F. I. Green, “Telephone”, *The Bell System Tech. J.*, vol. 37, no. 2, 1958, pp. 289–338.
- [13] F. William and M. D. Channing, “The telephone, with a sketch of its inventor, Philipp Reis”, *Popular Science Monthly*, vol. 23, 1883, pp. 540–551.
- [14] R. J. P. Weber and D. N. Perkins, (Eds.), *Inventive Minds: Creativity in Technology*. New York: Oxford University Press, 1992, pp. 48–79.
- [15] “Fundamentals of Telephone Communication Systems”, Western Electric Co., New York, NY, USA, 1969.
- [16] D. Mercer, *The Telephone: The Life Story of a Technology*. Westport, CT, USA: Greenwood Publishing Group, 2006.
- [17] *The Telephone in America*, American Telephone and Telegraph Company, New York, NY, USA, 1936 & 1952.
- [18] “Alexander Graham Bell – American inventor”, *Encyclopædia Britannica* [Online]. Available: <http://www.britannica.com/biography/Alexander-Graham-Bell>
- [19] L. Coe, *The Telephone and Its Several Inventors: A History*. Jefferson, NC: McFarland, 1995.
- [20] H. N. Casson, *The History of the Telephone*, 10th ed. Chicago, USA: A. C. McClurg & Co., 1922.
- [21] B. S. Finn, “Bell and Gray: just a coincidence?”, *Technology and Culture*, vol. 50, no. 1, pp. 193–201, 2009.
- [22] T. Farley and M. van der Hoek, “Telephone History: The Inventors Gray and Bell”, Jan, 2006 [Online]. Available: [http://www.privateline.com/mt\\_telephonehistory/2006/01/the\\_inventors\\_gray\\_and\\_bell.html](http://www.privateline.com/mt_telephonehistory/2006/01/the_inventors_gray_and_bell.html)
- [23] M. E. Gorman and W. B. Carlson, “Interpreting invention as a cognitive process: THE CASE of Alexander Graham Bell, Thomas Edison and the telephone”, *Science Technol. & Human Values*, vol. 15, no. 2, pp. 131–164, 1990.
- [24] A. G. Bell, “Experiments made by Alexander Graham Bell”, *Bell Notebooks Pages*, vol. I, p. 26, 1876.
- [25] C. Wheatstone, *The Scientific Papers of Sir Charles Wheatstone*. London: Taylor & Francis, 1879.
- [26] F. W. Wile, *Emile Berliner – Maker of the Microphone*. New York: Arno Press, 1974.
- [27] E. Berliner, “Improvement in electrical-contact telephones”, U.S. Patent no. 222652, Dec. 1879.
- [28] F. L. Dyer and T. M. Commerford, *Edison: His Life and Inventions*, vol. 1. New York: Harper & Brothers Publishers, 1910, p. 226.
- [29] B. Heil, “The microphone: a short illustrated history”, *QST*, vol. 90, no. 6, p. 50, 2006.
- [30] I. Wills, “Instrumentalizing failure: Edison’s invention of carbon microphone”, *Annals of Science*, vol. 64, no. 3, pp. 383–409, 2007.
- [31] I. Hughes, “Professor David Edward Hughes”, *AWA Review*, vol. 22, pp. 111–134, 2009.
- [32] D. M. Worrall, “David Edward Hughes: Concertinist and Inventor”, *Papers of the International Concertina Association (PICA)*, pp. 41–57, vol. 4, 2007.
- [33] Early Telephone Apparatus [Online]. Available: <http://www.sparkmuseum.com/TELEPHONE.HTM>
- [34] J. Klapholz, “History and development of microphones”, *Sound & Commun. Mag.*, Sept./Oct., 1986.
- [35] W. H. Martin, “Seventy-five years of telephone: an evolution in technology”, *Bell System Technical J.*, vol. 30, no. 2, pp. 215–238, 1951.
- [36] A. G. Bell, “Bell’s Experimental Notebook”, vol. 1, p. 40, 1876 (Manuscript Division, Library of Congress, USA).
- [37] A. A. Hurdeman, *Worldwide History of Telecommunications*. Hoboken, NJ, USA: Wiley, 2003, pp. 237–240.
- [38] T. Farley, *Telephone History Series* (Rev. 1), Aug. 2010, pp. 1–45 [Online]. Available: <http://www.privateline.com/TelephoneHistory/History1.htm>
- [39] A. L. Albert, *Electrical Communication*, 3rd ed. New York: Wiley and London: Chapman & Hall, 1954.
- [40] A. G. Bell, “Invention of telephone”, *Elec. Rev. & West. Electrician*, vol. 59, no. 20, pp. 972–974, 1911.
- [41] A. E. Evenson, *The Telephone Patent Conspiracy of 1876*. Jefferson, NC, USA: McFarland, 2000.
- [42] C. Beauchamp, “Who invented the telephone?: lawyers, patents, and the judgments of history”, *Technology & Culture*, vol. 51, no. 4, pp. 854–878, 2010.
- [43] S. Shulman, *The Telephone Gambit*. New York: W. W. Norton & Company, 2008.
- [44] R. O. Meyer and E. S. Grosvenor, “Did Alexander Graham Bell steal the telephone patent?”, *American Heritage*, vol. 58, no. 4, p. 52, 2008.
- [45] A. G. Bell, “Experiments made by Alexander Graham Bell”, *Bell Notebooks Pages*, vol. I, p. 85, 1876.
- [46] F. De Land, “Notes on development of telephone service. II”, *The Popular Science Monthly*, vol. 69, no. 3, pp. 490–501, 1906.
- [47] K. MacDonald, “Innovation in Cambridge – First Phone Call”, *Cambridge Historical Society*, 2002 [Online]. Available: <http://www.cambridgehistory.org/discover/innovation/First%20Phone%20Call.html>
- [48] S. E. McMaster, *The Telecommunication Industry*. Greenwood Press, 2002.
- [49] J. Brooks, *Telephone: The First Hundred Years*. New York: Harper & Row, 1976, pp. 40–41.
- [50] Telephone History, Bell Homestead National Historic Site, Brantford, ON, Canada [Online]. Available: <http://www.bellhomestead.ca>
- [51] Telephone Instruments 1877–1900, Illinois Bell’s Telephony Museum in Chicago, IL, USA [Online]. Available: <http://www.telephonymuseum.com/telephones.htm>
- [52] Worlds First Long Distance Telephone Line in French Corral, California Office of Historic Preservation, California State Parks, CA, USA, 1937.

- [53] Nevada County, California Reformation Prayer Network, Western Region, Live Oak, CA, USA.
- [54] Worlds First Long Distance Telephone Line 1878, Nevada County Historical Landmarks Commission, Nevada City, CA, USA.
- [55] C. Wolff, "The Ridge Telephone Company and the California Electric Works CD 130.1 Cobalt Blue Insulator", March 13, 2007 [Online]. Available: [http://www.insulators.info/articles/ridge\\_telephone.htm](http://www.insulators.info/articles/ridge_telephone.htm)
- [56] W. Preece, Hand-written notes by Sir William Preece from 1877 for Thomas Edison's newly invented "Speaking Telegraph", The IET Archives [Online]. Available: <http://www.theiet.org/resources/library/archives/featured/edison.cfm>
- [57] L. B. Firman, "Manual Service Exchanges: Multiple switch boards for Telephone Exchanges", U.S. Patent no. 252576, Jan. 1882.
- [58] T. Petruzzellis, *Telephone Projects for Evil Genius*. New York: McGraw-Hill, 2008.
- [59] I. N. McFee, *Famous Americans for Young Readers: The Story of Thomas A Edison*. New York: Barse & Hopkins, 1922.
- [60] T. Falzons Collection, Historic Butter Stamp Telephones, Australian Telephone Collectors Society (ATCS) Newsletter, July 2009 [Online]. Available: <http://www.telephonecollecting.org/Newsletter/July09.pdf>
- [61] J. K. La Rue, Early Telephone Apparatus, John K. La Rue's (JKL) Museum of Telephony, Dedicated to Preserving Telephony [Online]. Available: <http://jklmuseum.com>
- [62] Early Telephones, The Museum of Technology, Museum Libraries and Archives (MLA), Cambridge, UK, 2007.
- [63] S. N. D. North, Telephones and Telegraphs 1902, Department of Commerce Labor, US Bureau of the Census, Special Reports Government Printing Office, Washington, WA, USA, 1906.
- [64] Invention the Telephone, Intellectual Property of American Telephone and Telegraph Company (AT&T), 2014.
- [65] S. Adams and O. R. Butler, *Manufacturing the Future: A History of Western Electric*. New York: Cambridge University Press, 1999.
- [66] A. B. Iardella, "Western Electric and Bell System – A Survey of Service", Western Electric Company, New York, NY, USA, 1964.
- [67] R. Blodgett, *Timeless Values, Enduring Innovation: The Graybar Story*. Old Saybrook, CT, USA: Greenwich Publishing Group, 2009.
- [68] G. Adair, *Thomas Alva Edison: Inventing the Electric Age*. New York: Oxford University Press, 1996, pp. 59–65.
- [69] W. S. Pretzer, *Working at Inventing: Thomas A. Edison and the Menlo Park Experience*. Baltimore, Maryland, USA: The Johns Hopkins University Press, 2002.
- [70] G. M. Phelps, "Phelp's Crown Series of Telephones", U.S. Patent no. 218684, Aug. 19, 1879.
- [71] W. Lemstra, "Innovation and landscape in telecommunication industry – the paradigm shifts", in *Proc. 2nd Int. Conf. Compet. Regul. in New. Industry*, Brussels, Belgium, 2009, pp. 5–12.
- [72] L. Smith, "First Commercial Telephone Exchange – Today in History: January 28", New Haven – National Historic Landmarks, New Haven, New Haven County [Online]. Available: <http://connecticuthistory.org/the-first-commercial-telephone-exchange-today-in-history/>
- [73] R. Burlingame, *Engines of Democracy*. New York: Arno Press, 1976 (Reprint Edition, Ed. Charles Scribners Sons 1940, Reprinted from copy available in Newark Public Library, USA).
- [74] F. Deland, "Notes on the development of telephone service", *The Popular Science Monthly*, vol. 70, pp. 229–232, 1907.
- [75] V. Green, *Race on the Line: Gender, Labor, and Technology in the Bell System, 1880/1980*, 1st ed. Durham, NC, USA: Duke University Press Books, 2001.
- [76] R. J. Chapuis and A. E. Joel, *100 Years of Telephone Switching*, 2nd ed. Amsterdam: IOS Press, 2003, pp. 48–49.
- [77] K. D. Peterson, *Business Telecom Systems: A Guide to a Choosing Best Technologies and Services*. New York: CMP Books, 2000, pp. 23–24.
- [78] J. Cooley, "Viral Triggers: Telephony", Viral Networking Working Group, MIT Communications Futures Program, CFP Bi-Annual Meeting, MIT, Cambridge, MA, USA, Jan 25–27, 2005.
- [79] The Telephone offices: San Francisco Region Central offices [Online]. Available: <http://www.thecentraloffice.com/calif/SFO/San Francisco.htm>
- [80] C. Reynolds, *Albany Chronicles, A History of the City Arranged Chronologically, from the Earliest Settlement to the Present Time; Illustrated with Many Historical Pictures of Rarity and Reproductions of the Robert C. Pruyn Collection of the Mayors of Albany, Owned By the Albany Institute and Historical and Art Society*. J. B. Lyon Company, Albany, NY, USA, 1906, pp. 56–57.
- [81] History: AT&T Federal Internet Law and Policy – An Educational Project, Cybertelecom, 1997 [Online]. Available: <http://www.cybertelecom.org/notes/att.htm>
- [82] C. H. Sterling, P. W. Bernt, and M. B. H. Weiss, *Shaping American Telecommunications: A History of Technology, Policy, and Economics*. Mahwah, NJ, USA: Lawrence Erlbaum Associates Publishers, 2006.
- [83] K. B. Miller et al., *Encyclopedia of Telephony and Telegraphy*. Chicago American School of Correspondence, St. Lansing, IL, USA, 1919.
- [84] J. Gibson (Ed.), *Mobile Communications Handbook*. Boca Raton, FL, USA: CRC Press/IEEE Press, 1996.
- [85] A. Stone, *Public Service Liberalism – Telecommunication and Transition in Public Policy*. Princeton, NJ, USA: Princeton University Press, 1991.
- [86] The Bell – Western Union, Patent Agreement of 1879: ECCH the Case for Learning, INSEAD, Fountainbleau, France, 2005.
- [87] B. Estreich, "Emile Berliner" [Online]. Available: <http://telephonecollecting.org/berliner.pdf>
- [88] E. Berliner, "The improved gramophone", *Trans. American Instit. of Electr. Engin.*, vol. 8, no. 1, pp. 19–30, 1891.
- [89] Edison vs. Blake vs. Voelker vs. Irvin, Telephone Interface, Voelker's Specifications and Papers, Statements of Francis Blake Jr (Jul. 1878), Thomas A. Edison (Sep. 29, 1879), William I. Voelker (Nov. 1879), J. H. Irvin (Dec. 18, 1879), United Patent Office, IEEE Global History Network [Online]. Available: <http://ieeeghn.org>
- [90] E. Hall, *Francis Blake: An Inventor's Life (1850–1913)*. Boston, MA: Massachusetts Historical Society, 2005.
- [91] F. Blake, "Speaking Telephone", Patent no. 250126, United States Patent Office, 1881.
- [92] M. Martin, "Hello, Central?" – *Gender Technology and Culture in the formation of Telephone Systems*. Montreal, Quebec, Canada: McGill Queen's University Press, 1991, pp. 18–20.
- [93] W. J. Hammer, "An automatic telephone operator", *Trans. American Instit. of Electr. Engin.*, vol. 21, pp. 31–54, 1903.
- [94] W. D. Lockwood, "Evolution of telephone switchboard", *Trans. American Instit. of Electr. Engin.*, vol. 21, pp. 3–30, 1903.
- [95] C. M. Maxfield and A. Brown, *An Illustrated History of Electronics and Computing*, 2nd ed. Oxford, United Kingdom: Newnes Press, 2003.
- [96] F. B. Jewett, *Biographical Memoir of John Joseph Carty 1861–1932*. National Academy of Sciences of the United States of America Biographical Memoirs, Volume XVIII, Fourth Memoirs, 1936 [Online]. Available: <http://www.nasonline.org>.
- [97] L. B. Firman, "Multiple Switchboard for Telephone Exchanges", Western Electrical Manufacturing Company, U.S. Patent no. 252576, Jan. 1882.
- [98] "The Communications Era (1879–1905) – Extending Man's Voice by Wire and Radio" [Online]. Available: <http://customers.hbci.com/~wenonah/history/edpart3.htm>
- [99] Bicentennial issue of *Electronic Design* for engineers and engineering managers, vol. 24, no. 4, Feb. 16, 1976.
- [100] J. Race, "Old telephones: how to repair and rebuild them", Technical Notes, Cambridge Electronics Laboratories, Somerville, MA, USA, 2001.
- [101] D. Linn, R. Larese, and J. Pan, "E&M Signaling", White Paper, FAE Telecom, Acton, MA, USA [Online]. Available: [www.fae telecom.com](http://www.fae telecom.com)



- [102] "Principles of Electricity applied to Telephone and Telegraph Work", Bell Training Course Material, American Telephone and Telegraph Company, January, 1953 [Online]. Available: <http://wedophones.com/TheBellSystem/pdf/attbook.pdf>
- [103] R. MacDougall, "The Telephone on Main Street: Utility Regulation in the United States and Canada before 1900", *Business and Economic History*, vol. 4, 2006 [Online]. Available: <http://www.thebhc.org/sites/default/files/macdougall.pdf>
- [104] H. Schulzrinne, "Request for Comments 3966 (RFC-3966)", Columbia University Network Working Group, Dec. 2004 [Online]. Available: <http://www.ietf.org/rfc/rfc3966.txt>
- [105] J. E. Brittain, "The introduction of the loading coils: George A. Campbell and Michael I. Pupin", *Technol. & Culture*, vol. 11, no. 1, pp. 35–57, 1970.
- [106] J. E. Brittain, "Amazing biography of Michael I. Pupin", *IEEE Industry Appl. Mag.*, no. 1, Jan.-Feb., 2006.
- [107] H. F. Campbell, "Metallic Circuit", Patent no. 411137, United States Patent Office, Sept. 1889.
- [108] T. Shaw and W. Fondiller, "Developments and applications of loading coils for telephone circuits", *Trans. American Instit. of Electr. Engin.*, vol. 45, no. 3, pp. 291–292, 1926.
- [109] Almon B. Strowger 1839-1902 (Inventor), Kansas Sesquicentennial, 150 Years and counting Science in Kansas, Kansapedia, Kansas Historical Society, Ad Astra Kansas Initiative, 2010 [Online]. Available: [http://www.adastra-ks.org/150scientists/150scientists\\_Oct\\_3.pdf](http://www.adastra-ks.org/150scientists/150scientists_Oct_3.pdf)
- [110] R. B. Hill, "Early years of the Strowger system", *Bell Lab. Record*, vol. 31, no. 3, pp. 95–103, 1953.
- [111] R. B. Hill, "Early work on dial telephone systems", *Bell Lab. Record*, no. 1, pp. 22–29, 1931.
- [112] S. J. Bigelow, J. J. Carr, and S. Winder, *Understanding Telephone Electronics*, 4th ed. Oxford, United Kingdom: Newnes, 2001.
- [113] P. J. Povey and R. A. Earl, *Vintage Telephones of the World*. London: Peter Peregrinus Ltd., 1988.
- [114] "Alexander Graham Bell Speaking on the Phone, 1892", Gilbert H. Grosvenor Collection of Photographs, Prints and Photographs Division, Library of Congress, 1892.
- [115] H. H. Nance, "Some very long telephone circuits of the Bell system", *Bell System Technical J.*, vol. 3, no. 3, pp. 495–507, 1924.
- [116] A. Sarlemijn and P. Kroes, *Between Science and Technology: Proceedings of the International Conference Between Science and Technology, Eindhoven University of Technology, The Netherlands, 29-30 June 1989*. Amsterdam: North-Holland, 1990.
- [117] J. J. Pilliod, "Transcontinental telephone lines", *Bell System Technical J.*, vol. 18, no. 1, pp. 235–245, 1939.
- [118] R. B. Hill, "Early work of dial telephone system", *Bell Lab. Record*, vol. 31, no. 1, pp. 22–29, 1953.
- [119] E. Lindquist, "The invention and development of the dial telephone: the contribution of three Lindsborg inventors", *Kansas Historical Quarterly*, vol. 23, no. 1, pp. 1–8, 1957.
- [120] M. Csele, "Telephone Switches", Niagara College (US), July 22, 2014 [Online]. Available: <http://192.197.62.35/staff/mcsele/TelephoneSwitch.html>
- [121] J. H. Stevens, "Basic Relay Circuits" [Online]. Available: <http://www.kadiak.org/tel/index.html>
- [122] "Switches, PBX's, and Central Offices", Survey of Telephone Switching, The Pacific Telephone and Telegraph Company, 1956 [Online]. Available: <http://www.telephonetribute.com/switches.html>
- [123] "Attachments to Public Switched Telephone Network (PSTN); General technical requirements for equipment connected to an analogue subscriber interface in the PSTN; Chapter 1: General", series EN 300 001 v1.5.1 (1998-10), European Telecommunications Standards Institute, Jan. 1997 [Online]. Available: <http://www.etsi.org>
- [124] J. Bathgate, "Introduction to Strowger", The Dean Forest Railway Telecoms, Norchard Centre, Lydney, Forest of Dean, Gloucestershire, no. 131, UK, Jan. 2008 [Online]. Available: <http://www.dfrtelecoms.org.uk/pdf/basicex.pdf>
- [125] T. Viswanathan, *Telecommunication Switching Systems and Networks*. Delhi, India: Prentice Hall of India, 2004, pp. 40–43.
- [126] N. Wilkinson, *Next Generation Network Services*. Chichester, UK: Wiley, 2002.
- [127] I. Vogelsang and G. Woroch, "Local telephone service: a complex dance of technology, regulation and competition", in *Industry Studies*, 2nd ed., L. L. Deutsch, Ed. New York: M. E. Scharpe, 1998 [Online]. Available: <http://eml.berkeley.edu/~woroch/dance.pdf>
- [128] A. Lebedev, "A Short History of Telephone Numbers" (Manship project, graphic and industrial design, interface engineering, typography, semiotics, and visualization, since 1997), Art Lebedev Studio, New York, Moscow, Kiev, June 18, 2002 [Online]. Available: <http://www.artlebedev.com/mandership/91>
- [129] A. B. Clark and H. S. Osborne, "Long distance telephone circuits in cable", *Bell System Technical J.*, vol. 11, no. 4, pp. 520–545, 1932.
- [130] R. Juch, "AT&T Long Lines", The Bell System Unit For Nationwide and Worldwide Communications, 1969 [Online]. Available: <http://www.beatriceco.com/bti/porticus/bell/longlines.html>
- [131] R. MacDougall, "Long lines: AT&T, long distance telephony and corporate control", *Business and Economic History*, vol. 3, 2005 [Online]. Available: [http://www.thebhc.org/sites/default/files/macdougall\\_0.pdf](http://www.thebhc.org/sites/default/files/macdougall_0.pdf)
- [132] L. Carter *et al.*, "About Submarine Telecommunication Cables", International Cable Protection Committee Ltd, Lymington, United Kingdom, Oct. 2011 [Online]. Available: <https://www.iscpc.org/documents/?id=132>
- [133] "1927: Transoceanic Telephone Service" [Online]. Available: <http://www.corp.att.com/atlabs/reputation/timeline/27atlan.html>
- [134] "History of Telecommunications", CNES – Information Systems Directorate, Toulouse, France [Online]. Available: <https://cnes.fr/en/web/CNES-en/1105-history-of-telecommunications.php>
- [135] B. Burns, First Submarine Transatlantic Telephone Cable System TAT-1, FTL Design [Online]. Available: <http://atlantic-cable.com/Cables/1956TAT-1/>
- [136] E. C. Wente, "The condenser transmitter as a uniformly sensitive instrument for the absolute measurement of sound intensity", *Phys. Rev.*, vol. 10, no. 1, pp. 39–63, 1917.
- [137] E. C. Wente, "The sensitivity and precision of the electrostatic transmitter for measuring sound densities", *Phys. Rev.*, vol. 19, no. 5, pp. 498–503, 1922.
- [138] E. C. Wente, "Contributions of telephone research to sound pictures", AT&T Archives, Bell Telephone Laboratories, New York, Oct. 1935.
- [139] Federal Internet Law and Policy – An Educational Project, Cybertelecom, 1997 [Online]. Available: <http://www.cybertelecom.org/notes/telephone.htm>
- [140] G. William and A. Drummer, *Electronic Inventions And Discoveries: Electronics From Its Earliest Beginnings To The Present Day*. Boca Raton, FL: CRC Press, 1997.
- [141] P. J. Covey, "The Telephone and the Exchange", Post Office Publication, pp. 75–84, 1917.
- [142] C.-F. Helgesson, "The history of Eriksson: The crossbar switch from concept to success", Ericsson [Online]. Available: <http://www.ericssonhistory.com/products/the-switches/The-crossbar-switch—from-concept-to-success/>
- [143] P. Walker, "Crossbar Switching Systems", Telecommunication Heritage Group for preservation and collection of the heritage of communications, London, UK [Online]. Available: <http://www.thg.org.uk/index.php/telecoms/115-crossbar-switching>
- [144] "Swedish Telecom-Company History", Funding Universe, Farsta, Sweden [Online]. Available: <http://www.fundinguniverse.com/company-histories/swedish-telecom-history/>
- [145] R. L. Freeman, *Fundamentals of Telecommunications*, 3rd ed. Hoboken, NJ, USA: Wiley, 2005, pp. 73–77.





**Vinayak L. Patil**, received his B.Sc. in 1972, B.E. in 1975, M.E. in 1979 and Ph.D. in 1990. He worked as Scientist at Central Electronics Engineering Research Institute (CEERI), Pilani from 1977 to 1991 for 14 years and during his service at CEERI he worked on Electronics System Designs based on microprocessors and computers for agriculture and agro-based industries. The work done at CEERI resulted many national and international awards confirmed on the author. From 1991 to 1997 he

worked as a Director at Centre for Electronics Design and Technology (CEDT), Aurangabad, India (now National Institute of Electronics and Information Technology), where he promoted electronics product design for agriculture and agro-based industries. From 1997 he also worked in the capacity of directors and principals of various engineering colleges and presently working as a professor in Trinity College of Engineering and Research, University of Pune, Pune, India.

E-mail: patilvl.works@gmail.com  
Trinity College of Engineering and Research  
University of Pune  
Ganesh Khind  
411007 Pune, India