

INVESTIGATION OF DYNAMIC PROPERTIES OF VEHICLE IN VARIOUS FRICTION CONDITION SIMULATED WITH USE OF SKIDCAR SYSTEM

VIDAS ŽURAILIS¹, KRISTINA KEMŽURAITĖ², DARIUSZ WIĘCKOWSKI³

Summary

In this paper, the friction characteristics of a vehicle equipped with skidcar system are analyzed. Skidcar system with attached additional wheels helps to regulate the adhesion with the road surface. Easy slipping vehicle is a useful device for driving skills improvement, carrying out various vehicle dynamics and control research activities. Important reason of skidcar systems is an ability to set low friction values in dry and good contact road conditions. Regulation of friction characteristics extends the limits of the system operation. In this case, the identification of friction characteristics is important. Vertical load of wheels and critical horizontal forces are measured in each operating mode by changing skidcar system height. Furthermore, ISO4138 driving manoeuvre is performed to measure the vehicle accelerations, oscillations and slip parameters for friction evaluation in dynamic state.

The performed analysis could be useful for drivers training and for further vehicle stability and control researches upon using skidcar system.

Keywords: friction, skidcar system, vehicle control, vertical load, longitudinal force, lateral force, vehicle acceleration

1. Introduction

The friction characteristics of a vehicle mostly depend on the road surface. The latter is affected by various meteorological conditions, it has the own macro-profile; in addition, the road surface is covered with particles of ground, various substances and dust or snow [6]. The other factor important for adhesion with the road surface includes lateral and vertical loads that depend on the driving dynamics and the load of the vehicle. The properties of

¹ Vilnius Gediminas Technical University, Department of Automobile Transport, J. Basanavičius 28, 03-224 Vilnius, Lithuania, e-mail: vidas.zurailis@vgtu.lt

² Department of Automobile Transport, Vilnius Gediminas Technical University, J. Basanavičius 28, 03-224 Vilnius, Lithuania, e-mail: kristina.kemzuraite@vgtu.lt

³ Automotive Industry Institute, Jagiellońska 55, 03-301 Warsaw, e-mail: d.wieckowski@pimot.org.pl, tel. +48 777 70 92

the tires and the suspension of the vehicle are slightly less important for the adhesion. On driving a vehicle, appreciation of the said factors is of a great importance because it predetermines a duly control of the vehicle upon unexpected situations on the road [8, 16]. The properties of the road pavement surface directly affect the dynamics of the vehicle driving. Stability depends on the type of the road pavement as well as on its roughness and geometrical parameters [13]. The road unevenness causes vibrations and they, in their turn, affect the vehicle's control properties, its control and safety.

For improvement of driving skills, various simulators or training on a closed site (or a race track) are usually applied; however, in such cases, the drivers are often indirectly accustomed to high speeds and this is not always good with regard to traffic safety. For driver skills improvement, special practice grounds with expensive equipment for provoking vehicle skidding are arranged; however, there is an opportunity to feel the vehicle skidding and to accustom to control it without a necessity of dangerous speeds on turns or training at highly specialized centres. A skidcar system mounted on a real vehicle provides an excellent opportunity to feel sudden skidding upon a safe speed of driving. An assessment of the friction characteristics upon using the skidcar system in various operating mode by changing its height would enable choosing the desirable driving conditions in a more objective way and extending the limits of the system's application.

For analyzing the driving characteristics important for the vehicle's stability, a group of dynamic parameters that form a friction model of a vehicle is used [4]. In addition to the road data, such group of parameters includes lateral and longitudinal accelerations, vehicle body yaw rate, wheel's angular velocities, and a handwheel angle. The lateral speed of the vehicle (that is determined in an indirect way) is important as well.

For analyzing an interaction of a tire with various road surfaces, finite element simulation is applied [7]. This method provides an opportunity to analyze the tire and the road deformations as well as the contact area stress. The properties related to adhesion, pressure, traction and resistance are expressed through the dependence on the longitudinal and lateral tire skidding. Problematic tire contact properties upon applying the method of finite elements are analyzed by a Polish scientist [10]. Upon applying horizontal and vertical loads to a tire and changing its texture, different stiffness properties provides a positive effect upon traffic safety.

An assessment of adhesion of tires with a specific road surface is important for establishing the initial driving characteristics of a vehicle. Such a purpose is pursued by scientists and investigators involved in analyzing of circumstances of traffic events [5, 11]. The friction coefficient is calculated according to the skidding tracks caused by an extreme braking. On closer definition of the methodology, it was found that the friction coefficient is unstable during first five metres of braking. While analyzing traffic events and road characteristics, Italian scientists [3] found the dependence of the lateral friction coefficient on the driving velocity, the turning radius and the road profile superelevation. In the research, the road surface macrotexture skid resistance was assessed as well.

Precise assessment of the lateral forces that affect a vehicle and a wheel enabled French scientists to find the maximum value of the friction coefficient [15]. Striving to single out

the limit loads affecting a vehicle, filters eliminating noises of the characteristics were applied.

On modeling of control of a drifting vehicle, the friction coefficient is assessed upon applying the simplified Pacejka's model. In the said model, precise input parameters are important for lateral and longitudinal skidding [14]. English scientists analyze various cases of tire loading and the impact of the protector upon the friction characteristics [12]. The dependences of contact force in various cases of tire deformation are explored and adhesion is expressed upon using the tire microskidding phenomenon.

2. The principle of operation of skidcar system

The principal purpose of a skidcar system is a simulation of driving conditions on slip road surface (Fig. 1). Independently on the existing road conditions, regulation of the vertical load of the tire causes the relevant change of the adhesion and the vehicle is easier provided an opportunity of skidding. This half-real simulator is applied for improvement of driving skills. In addition, the system is also applicable for vehicle stability tests, simulation of various modes of driving, exploration of tire performance and other tests.



Fig. 1. Vehicle equipped with skidcar system and system control panel with 12V hydraulic power pack

Upon using the skidcar system, the wheel friction characteristics are changed by changing the vertical load of the tires. It is made upon using hydraulic cylinders, thus varying the height ΔZ of the system (Fig. 2). Each system operation mode raises the skidcar frame and vehicle's body about 37 mm. Pressure in the hydraulic system is controlled by a 12V hydraulic power pack (located in the luggage compartment of the car) controlled by the control panel in the vehicle saloon. On raising the system's frame fixed to the vehicle's body, a relevant part of the vehicle's weight is transferred to the extra wheels. The wheels of the skidcar system may easily rotate through the bearings, so the direction of the vehicle driving or skidding is not restricted.

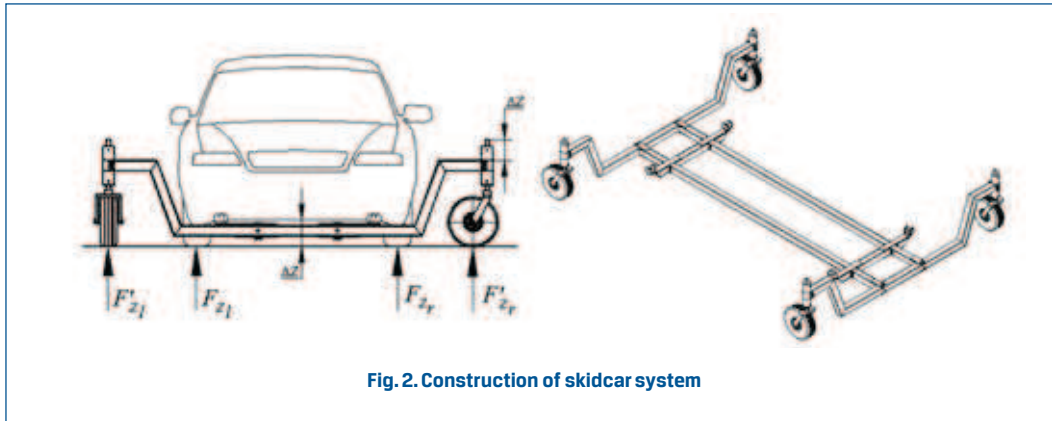

Fig. 2. Construction of skidcar system

The skidcar system is fixed to the body of the vehicle, so the suspension remains independent. However, the total freedom of vibrations of the unsprung vehicle's mass in the longitudinal and lateral directions undergoes changes. When the vehicle is raised, the stiffness and damping properties of the suspension cause partial changes of the tires of bearing wheels, so an adjustment of pressure in them is important. Deformations of elements of the skidcar system's frame are inconsiderable, so they are neglected in analysis of influence of various factors on vehicle movement.

3. Friction evaluation

Total three types of adhesion between an elastic tire and the road surface are singled out:

1. molecular adhesion friction between tire and road pavement;
2. surfaces deformation friction;
3. surfaces wear friction

The interaction of particles of the contact surfaces is based on instantaneous adhesion of the surfaces. Particles of rubber surface of the tire interact with the road surface, so adhesion depends on the area of the contact surface: if the area is larger, a bigger number of the particles are involved in the interaction. The contact pressure is an important factor in interaction of the surfaces. When the pressure grows, a greater force is required to separate the surfaces, so adhesion grows. In absence of a direct contact between the surfaces (when the road surface is covered with water, snow and so on), adhesion falls dramatically because of lack of interaction of particles.

It is evident that both the tire and the road surface are not ideally even. Upon bad weather conditions, this circumstance causes additional skidding. Because of deformation of tire with vertical load, its surface better adapts to bumps of the road surface, is able to freeze onto them and thus increase the contact area. Because of specific elasticity of the tire carcass, the contact surface in various cases of rolling is able to expand and to freeze onto elements of the road surface, thus causing additional increasing of adhesion.

Generally speaking, grip properties of two surfaces are defined by the friction coefficient. It shows the maximum force that may affect the body in case of constant vertical load:

$$\sqrt{F_x^2 + F_y^2} = \mu_{xy} \cdot F_z; \quad (1)$$

where: F_x, F_y – the longitudinal and the lateral force that affect the tire, respectively;
 μ_{xy} – the friction coefficient;
 F_z – the vertical load of the tire.

Adhesion is found upon applying Burckhardt's method [2]:

$$\mu = (c_1 \cdot (1 - e^{-c_2 \cdot s}) - c_3 \cdot s) \cdot e^{-c_4 \cdot s \cdot v} \cdot (1 - c_5 F_z^2); \quad (2)$$

where: c_1, c_2, c_3 – the coefficients that depend on the road surface;
 c_4 – the coefficient that defines the speed of a higher drive;
 c_5 – the coefficient that depends on the wheel load;
 v – the driving velocity;
 s – the longitudinal wheel slip.

On manoeuvres in real cases of driving when the tire is affected by a lateral force, lateral skidding appears. If tire side slip angle and tire lateral stiffness are known, friction in the lateral direction may be expressed as follows:

$$\mu_y = \frac{\alpha \cdot C_\alpha}{F_z}; \quad (3)$$

where: α – tire side slip angle;
 C_α – tire lateral stiffness

Thus, operation of a skidcar system is based on a controllable vertical load of the tire and when the said load is transferred to the extra wheels of the system, an appearance of vehicle skidding requires considerably less lateral force and lower velocity.

3. Evaluation of skidcar system's static friction

Upon striving to establish four driving conditions for different friction characteristics, the whole skidcar system's elevation range was divided to four parts. The mode of the maximum height conforms to the least adhesion properties and the mode of full drooping – to the best adhesion. The height of the system impacted deformation of tires and the load transfer to the contact zone (Fig. 3). The load distributions on rolling and static mode differ; however, the total load of the system remains the same.

The static friction coefficient was found on pulling the braked vehicle in the longitudinal and lateral direction (Fig. 4). On the pulling, the wheels of the vehicle were held back by the service brake and the skidcar system was adjusted for one of four elevation modes. For measuring the tension force, a dynamometer was embedded into the pulling rope.

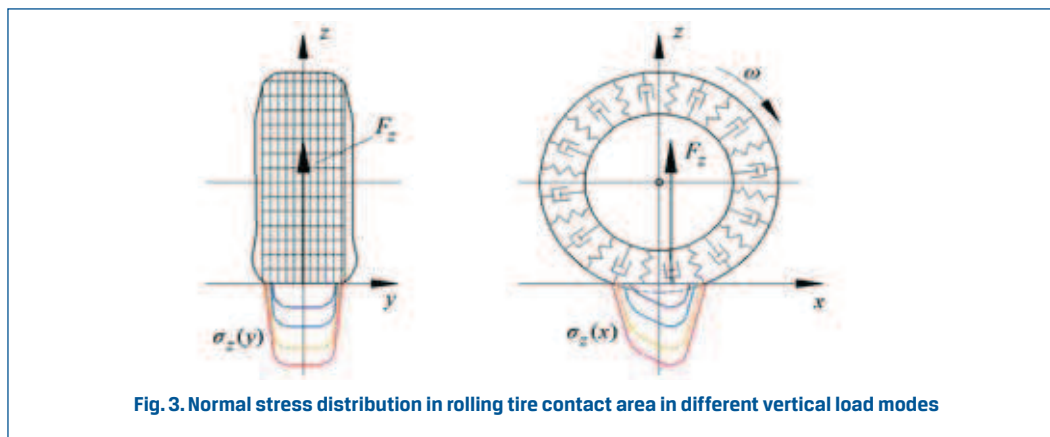

Fig. 3. Normal stress distribution in rolling tire contact area in different vertical load modes

Before pulling, the distribution of static vertical loads between wheels of the vehicle and the skidcar system was found upon using an axial weighing machine. The results of the experiment are provided in Table 1 below.

Table 1. Values of static experiment

Skidcar system operation mode	Static vertical load of skidcar system extra wheels, N		Static vertical load of vehicle wheels, N		Common load, N	Tension force, kN		Friction coefficient	
	Front axle	Rear axle	Front axle	Rear axle		F_x	F_y	μ_x	μ_y
I	1050	900	7800	6150	15900	9.82	9.56	0.630	0.613
II	2250	2050	6600	5050	15950	8.2	8.05	0.524	0.514
III	3300	3150	5550	3900	15900	6.72	6.48	0.431	0.415
IV	4600	4350	4300	2700	15950	4,8	4.67	0.307	0.298

As it was expected, the total mass of the vehicle and the skidcar system was almost the same in all height modes. The values vary only within the limits of measuring errors of the weighing machine (± 5 kg). In each elevation mode, the vertical loads between the vehicle wheels and the skidcar system's extra wheels transfer by about 1.2 kN.

The skidcar system was mounted on car Mazda 626. The driving wheels of the vehicle are its front wheels and the engine is built laterally in the front part of the vehicle. Summer tires R14/185/65 are used in it.

As it may be seen from the data on the experiment provided in the Table 1 and the values found upon using the formula 1, the friction coefficient varies between 0.298 for the case of the maximum height and 0.630 for the case of the minimum height. The friction coefficient does not reach the values applicable for dry asphalt (0.8–0.9), because the total weight of the system is increased because by the additional construction. In addition, the value



Fig. 4. Pull experiment for evaluation of longitudinal and lateral friction

of the friction coefficient in the longitudinal direction of the vehicle is higher by 1.8–3.6 %. This trend is not in conflict with the properties described in the works reviewed by foreign scientists. So, using a skidcar system enables adjusting the friction characteristics equivalent to driving on wet or snowy road surface.

4. Dynamic friction evaluation of skidcar system

For evaluation of the dynamic friction coefficient, driving experiments were arranged according to standard ISO 4138. According to provisions of the said standard, the vehicle was driven along a circle of the preset radius and its velocity was gradually increased. Driving took place until the vehicle skids away from the foreseen driving trajectory. Dynamic characteristics of the vehicle are measured by the built-in *Corrsys-Datron* equipment (Fig. 5). The experiment is repeated upon different heights of the skidcar system and different driving radii.



Fig. 5. Vehicle equipped with skidcar system and dynamic parameters measure sensors

When the vehicle reaches the critical velocity, it skids away from the foreseen driving trajectory and its acceleration at the said moment may be used for evaluation of the lateral friction coefficient [17].

$$\mu_y = \frac{F_y}{F_z} = \frac{ma_y}{mg} = \frac{a_y}{g}; \quad (4)$$

where: m – mass of the vehicle with the mounted equipment;

a_y – lateral acceleration;

g – gravitational acceleration.

Table 2. Values of evaluation of lateral friction coefficient

Skidcar system operation mode	Critical lateral acceleration, a_y , m/s ²	Lateral friction coefficient, μ_y
I	6.04	0.616
II	5.50	0.561
III	4.17	0.425
IV	3.20	0.326

In the Table 2, the results of evaluation of dynamic friction coefficient are provided. The values of lateral friction coefficients found in the static and the dynamic way do not differ considerably, so the results of the experiments and the chosen methodology are correct.

On speeding-up, a vehicle with a skidcar system achieves a lower acceleration. On varying the height of skidcar system, the wheels are prone to skidding, i.e. angular speed of the driving wheels exceeds the longitudinal speed of the vehicle. During the experiments, the equipment for fixing dynamic parameters measured the angular speeds of the driving wheels. The optical sensor *Correvit S350 Aqua* in the front part of the vehicle measured the linear speed of the body according to the changes of the road surface. If the said parameters and the radius of the wheel during the driving are known, the wheel skidding is found as follows:

$$s_x = \frac{\omega_r \cdot r_r - v_x}{\omega_r \cdot r_r}; \quad (5)$$

where: ω_r – angular speed of the wheel;

r_r – wheel rolling radius;

v_x – longitudinal linear speed of the vehicle.

For establishing the maximum adhesion of a tire with the road surface according to relative skidding, a nonlinear evaluation is applied [1, 9]; for precise determination of the coefficients of the expression, RLS (recursive least squares) algorithm is used:

$$\mu = \frac{\mu_0 \cdot s}{s^2 c_2 + s c_1 + 1}; \quad (6)$$

where: μ'_o – slope of the slip curve at zero slip;
 c_1, c_2 – shaping parameters according to the road surface (to be closer defined by RLS);
 s – longitudinal wheel slip.

Because the value of the calculated friction coefficient highly depends on the chosen values of the coefficients c_1, c_2 , it should be purposeful to calculate it upon using the expression that depends on drive torque:

$$\mu = \frac{I_w \dot{\omega}_r \pm T}{F_z \cdot r_r}; \quad (7)$$

where: I_w – wheel moment of inertia;
 $\dot{\omega}_r$ – wheel angular acceleration;
 $+T$ – brake torque;
 $-T$ – drive torque (acceleration mode).

In the experiments, the wheel slip-friction characteristic on different road pavements was established [4, 9, 11, 15]. It was found from the speeding-up characteristic of a vehicle equipped with a skidcar system that the values of slipping vary in the range between 0.25 and 0.7. According to the trends typical for the slip-friction characteristic, in this zone the values of the friction coefficient start falling. The unstable zone of the characteristic points out that the dependence is sensitive to external factors. This circumstance justifies an incomplete conformity of the values of slipping to the values of adhesion established in earlier experiments.

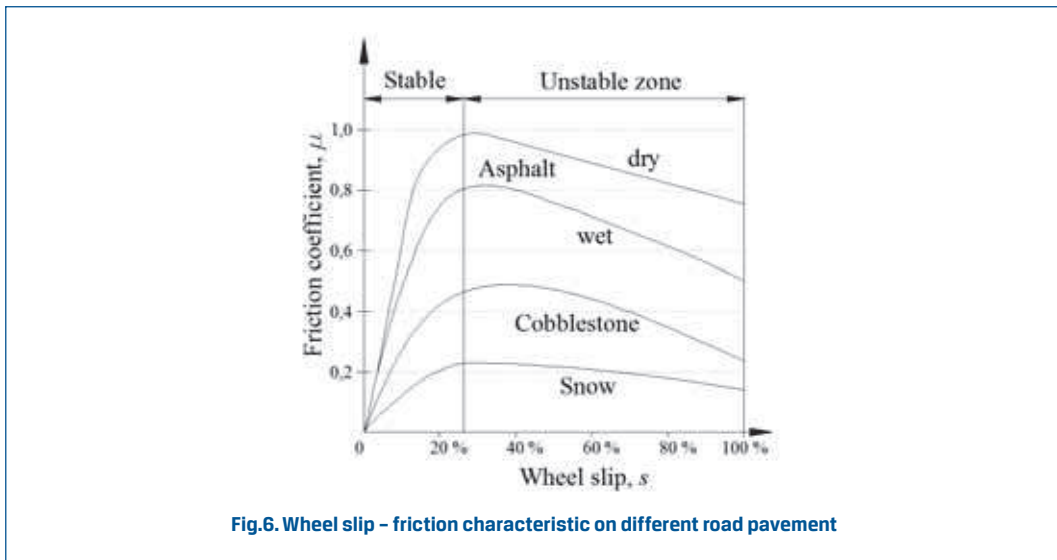
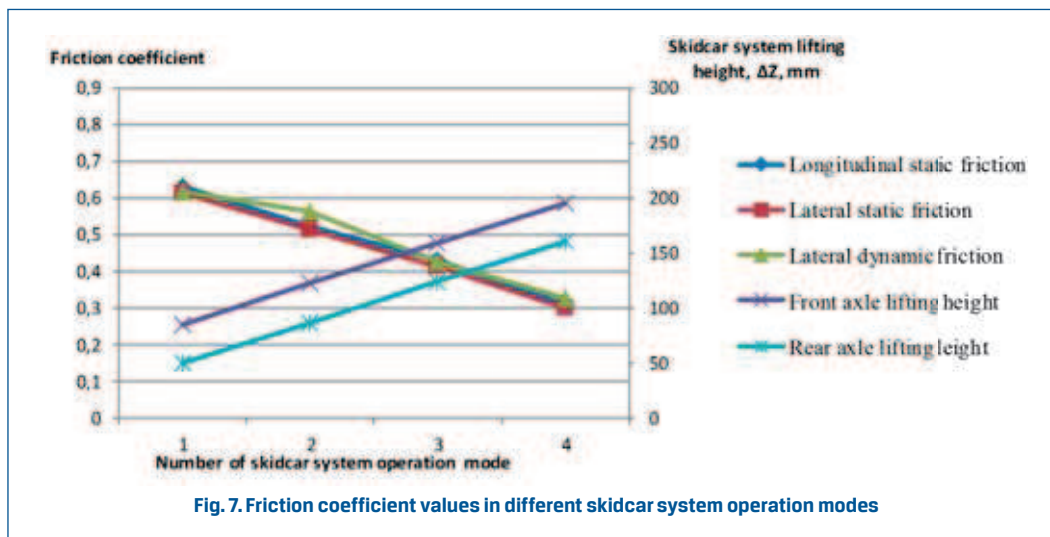

Fig.6. Wheel slip – friction characteristic on different road pavement

In all cases, a similar trend of the friction coefficient decrease dependently on the height of the skidcar system was observed. On increasing the height, a proportional decrease of the friction coefficient takes place.



4. Conclusions

In the paper, the influence of skidcar system on adhesion characteristics of the vehicle is analyzed. Four versions of the skidcar system's elevation height were chosen and the weight load transfer between the vehicle wheels and the system's extra wheels was evaluated for each case. On the vehicle pulling in the longitudinal and lateral directions, the relevant static friction coefficients were found: dependently on the skidcar system height, their values vary between 0.298 and 0.630.

Although the skidcar system does not restrict freedom of movement of the vehicle suspension, nevertheless the values of the friction coefficient of a vehicle equipped with such a system are less than typical ones for the chosen road pavement. It is caused by a larger total weight of a vehicle equipped with a skidcar system.

In order to ensure a reliability of the established values of friction coefficients, additional dynamic tests were carried out. The fixed parameters of velocity, acceleration and angular speed of wheel rotation of a vehicle with a skidcar system moving in a circular trajectory were used for establishing the values of friction coefficient. In the calculations, the methodology of critical movement parameters and Burckhardt's methodology were applied.

The trends of variation of the values of friction coefficients found upon applying different methods are the same. So, it may be stated that the friction characteristics of the skidcar system in different operation modes were identified correctly and the obtained results

may be usable as information parameters on applying the system for improvement of driving skills or for further dynamic research activities.

References

- [1] BURCKHARDT M.: *Fahrwerktechnik: Radschlupf-Regelsysteme*. Vogel Verlag, Wurzburg (1993).
- [2] CANUDAS-DE-WIT C., TSIOTRAS P., VELENIS E., BASSET M., GISSINGER G.: *Dynamic Friction Models for Road/Tire Longitudinal Interaction*. Vehicle System Dynamics, Vol. 39, No. 3 (2003) 189–226.
- [3] CRISMAN B., ROBERTI R.: *Tire wet-pavement traction management for safer roads*. Procedia - Social and Behavioral Sciences 53 (2012) 1055–1068.
- [4] GRIP H.F., IMSLAND L., JOHANSEN T.A., FOSSEN T.I., KALKKUHLL J.C., SUISSA A.: *Nonlinear vehicle velocity observer with road-tire friction adaptation*. Automatica 44 (2008) 611–622.
- [5] HEINRICHS B.E., ALIN B.D., BOWLER J.J., SIEGMUND G.P.: *Vehicle speed affects both pre-skid braking kinematics and average tire/roadway friction*. Accident Analysis and Prevention 36 (2004) 829–840.
- [6] KEMZŪRAITĖ K.; BUREIKA G.; ŽURĀULIS V. *Investigation of vehicle stability on road curves in winter conditions*. Transport Means – 2011: proceedings of the 15th international conference, Lithuania, Kaunas, 2011. 104–107.
- [7] LEE J.H.: *Finite element modeling of interfacial forces and contact stresses of pneumatic tire on fresh snow for combined longitudinal and lateral slips*. Journal of Terramechanics 48 (2011) 171–197.
- [8] LOZIA Z., WIĘCKOWSKI D., ŻARDECKI D.: *Wpływ luzu i tarcia w układzie kierowniczym na kierowalność samochodu*. [Steering system backlash and friction effects in car lateral dynamics]. Politechnika Świętokrzyska, Zeszyty Naukowe nr 8 Budowa i Eksploatacja Maszyn, 2008, 89–120.
- [9] MULLER S., UCHANSKIJ M., HEDRICK K.: *Estimation of the maximum tire-road friction coefficient*. Journal of Dynamic Systems, Measurement, and Control, Vol. 125 (2003) 607–617.
- [10] PELC J.: *Towards realistic simulation of deformations and stresses in pneumatic tires*. Applied Mathematical Modelling 31 (2007) 530–540.
- [11] SOKOLOVSKIJ E., PEČELIŪNAS R.: *The influence of road surface on an automobile's braking characteristic*. Strojniški vestnik – Journal of mechanical engineering. Ljubljana: Association of Mechanical Engineers of Slovenia, Vol. 53, No. 4 (2007) 216–223.
- [12] TSIOTRAS A., MAVROS G.: *Frictional contact behaviour of the tire: The effect of tread slip on the in-plane structural deformation and stress field development*. Vehicle System Dynamics, Vol. 48, No. 8 (2010) 891–921.
- [13] VANSĀUSKAS V., BOGDĒVIČIUS M. *Investigation into the Stability of Driving an Automobile on the Road Pavement with Ruts*. Transport, Vol. 24, No. 2 (2009) 170–179.
- [14] VELENIS E., KATZOURAKIS D., FRAZZOLI E., TSIOTRAS P., HAPPE R.: *Steady-state drifting stabilization of RWD vehicles*. Control Engineering Practice 19 (2011) 1363–1376.
- [15] VILLAGRA J., D'ANDRE' A-NOVEL B., FLIESS M., MOUNIER H.: *A diagnosis-based approach for tire-road forces and maximum friction estimation*. Control Engineering Practice 19 (2011) 174–184.
- [16] WIĘCKOWSKI D., STAŃCZYK, T. *Ocena poprawności wykonania typowych manewrów w ruchu samochodu* [Assessment of correct execution of typical traffic manoeuvre]. Zeszyty Naukowe Mechanika Nr 84, 2006. Wydawnictwo Politechniki Świętokrzyskiej, Kielce, 293–304.
- [17] ŽURĀULIS V., SOKOLOVSKIJ E., MATIJOŠIUS J.: *The opportunities for establishing the critical speed of the vehicle on research in its lateral dynamics*. Maintenance and Reliability = Eksploatacja i Niezawodność, Lublin: Polish Maintenance Society. Vol. 15, No. 4 (2013) 312–318.
- [18] ISO 4138:2004(E): *Passenger Cars – Steady-state Circular driving behavior – Open-loop Test Methods*. International Organization for Standardization. Geneva.