

Pavel Záskalický
 Technical University of Košice, Slovakia

STUDY OF CURRENT SPACE PHASOR TRAJECTORY OF THE THREE-PHASE ASYNCHRONOUS MOTOR WITH ONE PHASE OPEN CIRCUIT FAULT

BADANIE TRAJEKTORII PRZESTRZENNEGO FAZORA PRĄDU SILNIKA ASYNCHRONICZNEGO TRÓJFAZOWEGO PRZY USZKODZENIU JEDNEJ FAZY

Abstract: The presented paper deals with the calculation of space phasor trajectory of the magnetization current of induction machine supplied by a converter under open-phase fault. To explore possibilities to reduce the impact of failure on the function of the machine is a winding node connected to zero point. Under open phase fault it is another possibility to improve behavior of the two-phase operation. There is still to apply a circular rotating magnetic field to the machine by imposing a 60° phase shift between the stator currents of the two supplied stator windings.

Keywords: Fourier series, asynchronous motor, two-phase operation, fault-tolerance

1. Introduction

Reliability of an electrical drive has been always a primary requirement concern in many industrial application. The requirement of reliability is related to the concept of fault tolerance drive system. The electrical drive usually consists of electrical motor supplied by a semiconductor inverter and a suitable control strategy which is able to manage the drive system during a fault.

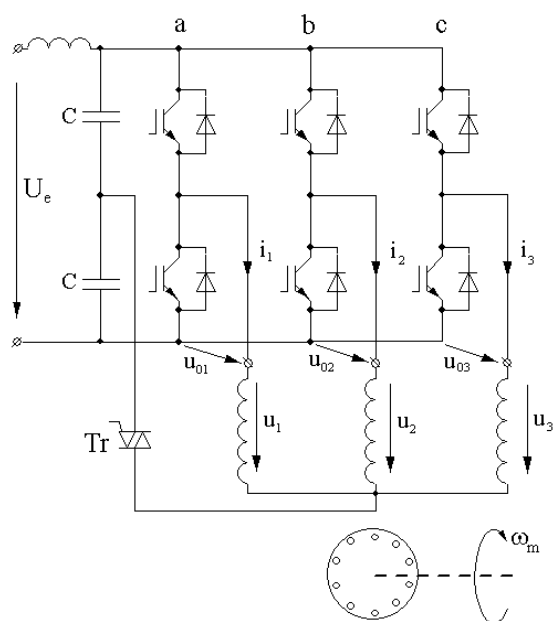

Fig. 1. Inverter supplied three-phase AM drive

The most frequently used drive of recent times is frequency-controlled three-phase asynchronous motor supplied from a voltage source inverter. A frequent failure state is a failure of one phase of inverter as the result of current overload of power transistors. Minimize disruption of the inverter is achieved by short-circuit transistors protection in each of transistors leg. The feature is achieved by means of the reconfiguration of the inverter structure during the fault of inverter. The inverter fault tolerant capability is related to the drive coast and the desired system reliability level.

2. Inverter mathematical model

For inverter's operation study at steady state we consider following idealized conditions:

- Power switch, that means the switch can handle unlimited current and blocks unlimited voltage.
- The voltage drop across the switch and leakage current through switch are zero.
- The switch is turned on and off with no rise and fall times.
- Sufficiently good size capacity of the input voltage capacitors divider, so we can assume that converter input DC voltage is constant for any output currents.

This assumptions help us to analyze a power circuit and help us to build a mathematical model for the inverter at steady state.

If the desired reference voltage is sine-wave, two parameters define the control:

- *Coefficient of the modulation* m - equal to the ratio of the modulation and reference frequency.
- *Voltage control coefficient* r - equal to the ratio of the desired voltage amplitude and the DC supply voltage.

The leg transistors are controlled to create the output leg voltages (phase-to negative rail of the DC bus 0) of the form

$$\begin{aligned} u_{01} &= \frac{U_e}{2} + r \frac{U_e}{2} \sin \theta; \\ u_{02} &= \frac{U_e}{2} + r \frac{U_e}{2} \sin \left(\theta - \frac{2\pi}{3} \right); \\ u_{03} &= \frac{U_e}{2} + r \frac{U_e}{2} \sin \left(\theta + \frac{2\pi}{3} \right) \end{aligned} \quad (1)$$

The coefficient of the modulation divides desired period of output voltage to m intervals with $\frac{2\pi}{m}$ width. In each of intervals it is necessary to create a voltage pulse whose area is equal to the area bounded by the desired waveform of the output voltage within the interval.

We assume that the front pulse is defined by angle α_n and back pulse by angle β_n . Comparing the areas we receive for the angles of the n -th voltage interval following formulas

$$\begin{aligned} \alpha_n &= \frac{\pi}{m} \left(2n - \frac{1}{2} \right) + \frac{r}{2} \left[\cos n \frac{2\pi}{m} - \cos \frac{\pi}{m} (2n - 1) \right] \\ \beta_n &= \frac{\pi}{m} \left(2n + \frac{1}{2} \right) + \frac{r}{2} \left[\cos n \frac{2\pi}{m} - \cos \frac{\pi}{m} (2n + 1) \right] \end{aligned} \quad (2)$$

We can output voltage of the first inverter leg to express as a complex Fourier series of the form

$$\begin{aligned} u_{01} &= \frac{U_e}{2} + 2U_e \sum_{k=1}^{\infty} \sum_{n=1}^m c_n e^{jk\theta}; \\ \begin{cases} c_n = \frac{1}{j2k\pi} (e^{-jk\alpha_n} - e^{-jk\beta_n}) \\ \text{valid for } k \neq 0 \end{cases} \end{aligned} \quad (3)$$

Where: U_e is inverter input DC voltage
Output voltages of the other two transistor legs can be expressed by the relations

$$u_{02} = u_{01} a; \quad u_{03} = u_{01} a^2; \quad (4)$$

where: a is shift coefficient defined as $a = e^{-j\frac{2k\pi}{3}}$

Assume the wye connection of the stator winding, the phase voltages can be expressed as

$$\begin{aligned} u_1 &= \frac{2}{3} U_e \sum_{k=1}^{\infty} \sum_{n=1}^m c_n (2 - a - a^2) e^{jk\theta} \\ u_2 &= \frac{2}{3} U_e \sum_{k=1}^{\infty} \sum_{n=1}^m c_n (2a - a^2 - 1) e^{jk\theta} \\ u_3 &= \frac{2}{3} U_e \sum_{k=1}^{\infty} \sum_{n=1}^m c_n (2a^2 - 1 - a) e^{jk\theta} \end{aligned} \quad (5)$$

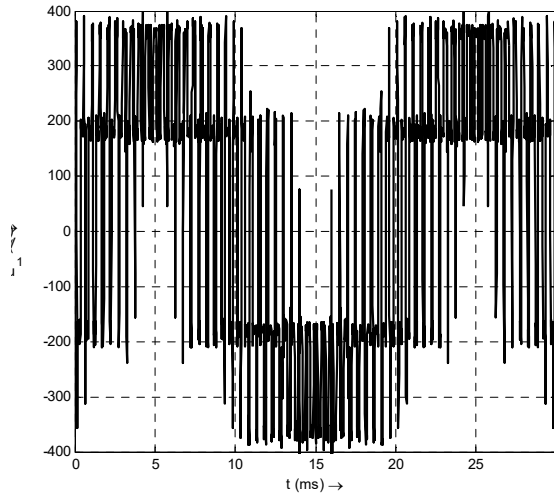

Fig. 2. Phase voltage waveform

The Fig.2 depicts the phase voltage waveform calculated on the base of equation (5). The waveform was calculated for DC input voltage $U_e = 540V$, output frequency $f = 50Hz$ and modulation frequency $f_m = 2kHz$ ($m = 40$).

3. Magnetization current space phasor trajectory

A space phasor of magnetization current is closely related to the size and shape of the rotating magnetic field of the machine.

Spatial phasor is calculated from the phase currents and follow by Clark transformation. The phase current will be calculated from phase voltages

$$\begin{aligned} i_1 &= \frac{2}{3} U_e \sum_{k=1}^{\infty} \sum_{n=1}^m c_n (2 - a - a^2) \frac{e^{jk\theta}}{R_1 + jk\omega L_1} \\ i_2 &= \frac{2}{3} U_e \sum_{k=1}^{\infty} \sum_{n=1}^m c_n (2a - a^2 - 1) \frac{e^{jk\theta}}{R_1 + jk\omega L_1} \\ i_3 &= \frac{2}{3} U_e \sum_{k=1}^{\infty} \sum_{n=1}^m c_n (2a^2 - 1 - a) \frac{e^{jk\theta}}{R_1 + jk\omega L_1} \end{aligned} \quad (6)$$

Where: R_1 is stator winding resistance and L_1 is stator winding inductance for no loaded machine

$$\begin{bmatrix} i_\alpha \\ i_\beta \\ i_0 \end{bmatrix} = \frac{2}{3} \begin{bmatrix} 1 & -\frac{1}{2} & -\frac{1}{2} \\ 0 & \frac{\sqrt{3}}{2} & -\frac{\sqrt{3}}{2} \\ \frac{1}{2} & \frac{1}{2} & \frac{1}{2} \end{bmatrix} \begin{bmatrix} i_1 \\ i_2 \\ i_3 \end{bmatrix};$$

$$i_\alpha = \frac{1}{3}(2i_1 - i_2 - i_3); \quad i_\beta = \frac{1}{\sqrt{3}}(i_2 - i_3); \quad (7)$$

$$i_0 = \frac{1}{3}(i_1 + i_2 + i_3);$$

The Fig.3 shows the current space phasor trajectory for no faulted machine. For calculus were taken a parameters 4,4kW asynchronous machine with stator resistance $R_1 = 1\Omega$ and stator inductance $L_1 = 15mH$.

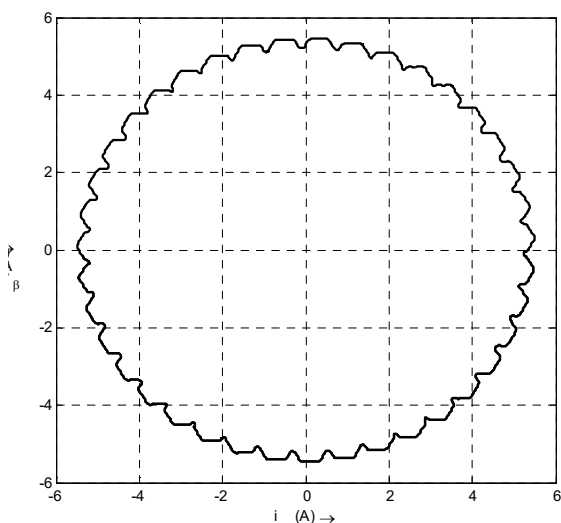

Fig. 3. Current space phasor trajectory for no faulted machine

4. One-phase open circuit fault

In case of loss one of phase will be two of uninterrupted phases connected in series and supplied by the line voltage of the inverter.

$$u_{12} = 2U_e \sum_{k=1}^{\infty} \sum_{n=1}^m c_n (1-a) e^{jk\theta} \quad (8)$$

In Fig.4 is shown the waveform of an inverter output line voltage.

The current is given by

$$i_1 = U_e \sum_{k=1}^{\infty} \sum_{n=1}^m c_n (1-a) \frac{e^{jk\theta}}{R_1 + jk\omega L_1} = -i_2; \quad (9)$$

$$i_3 = 0;$$

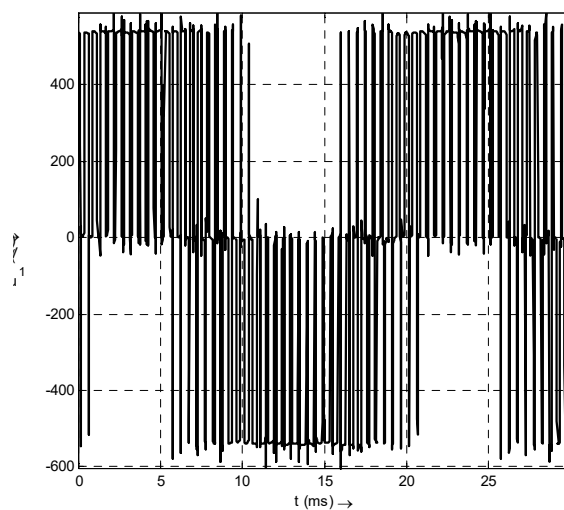

Fig. 2. Line voltage waveform

Space phasor of magnetizing current is pulsed, just as the magnetic field of the stator. Fig. 5 shows the trajectory of the space current phasor calculated on the base of equations (9).

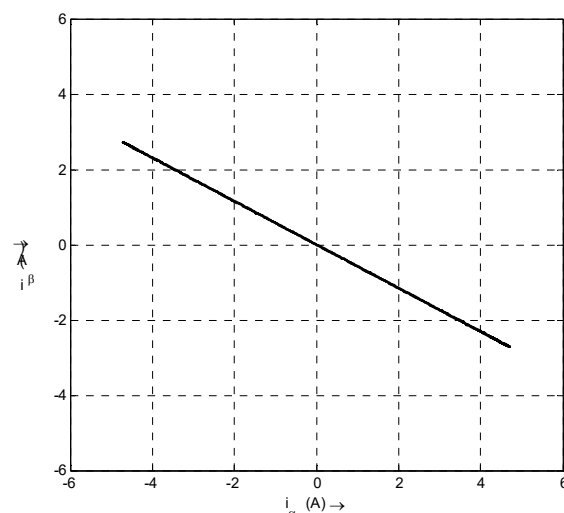

Fig. 5. Current space phasor trajectory for faulted machine

Motor has lost starting torque, continued operation is not possible.

5. Two-phase operation

Despite the failure of one phase, there is still possibility to create on the stator elliptic rotating magnetic field. The solution is to connect the neutral point of the stator winding to the middle point of the DC bus as can be seen in the Fig.1. After the node is connected to

the zero point of the DC bus, the phase voltages are given by equations

$$u_1 = 2U_e \sum_{k=1}^{\infty} \sum_{n=1}^m c_n e^{jk\theta}; \quad u_2 = a u_1 \quad (10)$$

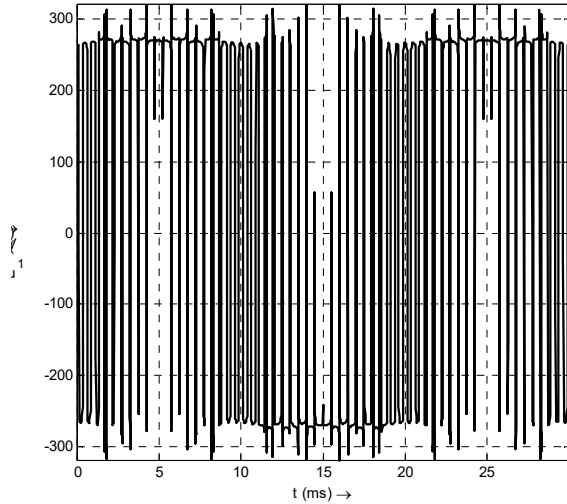

Fig. 7. Phase voltage waveform with connected node to zero point

For the currents following equations are valid

$$i_1 = 2U_e \sum_{k=1}^{\infty} \sum_{n=1}^m c_n \frac{e^{jk\theta}}{R_1 + jk\omega L_1}; \quad i_2 = a i_1 \quad (11)$$

After Clark transformation

$$\begin{aligned} i_\alpha &= \frac{2}{3} U_e \sum_{k=1}^{\infty} \sum_{n=1}^m c_n (2-a) \frac{e^{jk\theta}}{R_1 + jk\omega L_1} \\ i_\beta &= \frac{2}{\sqrt{3}} U_e \sum_{k=1}^{\infty} \sum_{n=1}^m c_n a \frac{e^{jk\theta}}{R_1 + jk\omega L_1} \\ i_0 &= \frac{2}{3} U_e \sum_{k=1}^{\infty} \sum_{n=1}^m c_n (1-a) \frac{e^{jk\theta}}{R_1 + jk\omega L_1} \end{aligned} \quad (12)$$

Trajectory of the current space phasor is elliptical, as shown in the Fig. 8.

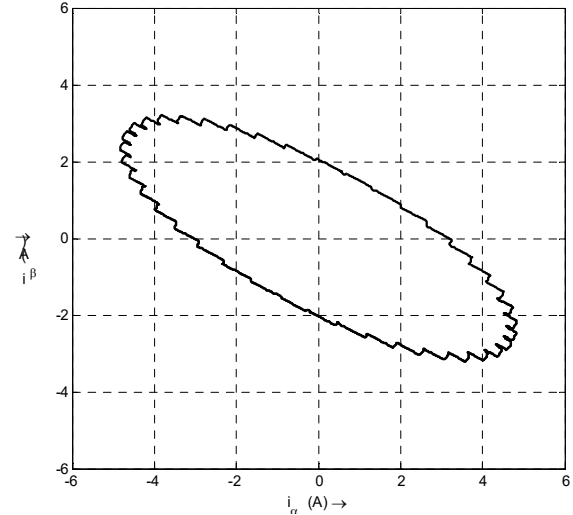

Fig. 8 Current space phasor trajectory with connected node to zero point

Variable size of current space phasor cause varying the magnetic field around the perimeter of the stator. But resulting is higher electromagnetic torque ripple.

6. Circular rotating magnetic field

There is an important conclusion, that under open phase fault it is still possible to apply a circular rotating magnetic field to the machine by imposing a 60° phase shift between the stator currents of the two supplied stator windings.

The equation (11) and (12) for calculating the stator currents are still valid. The shift coefficient is now defined as $a = e^{-j\frac{2k\pi}{6}}$.

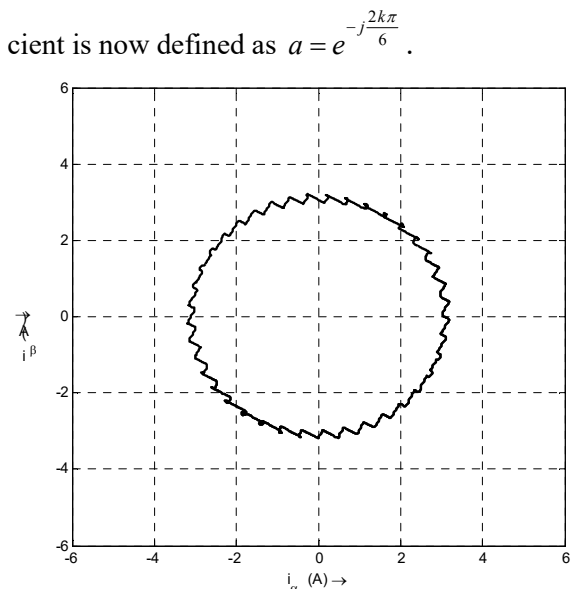

Fig. 9. Current space phasor trajectory for 60° phase shift

Fig. 9 depicts the trajectory of the current space phasor for 60° phase shift between the stator current.

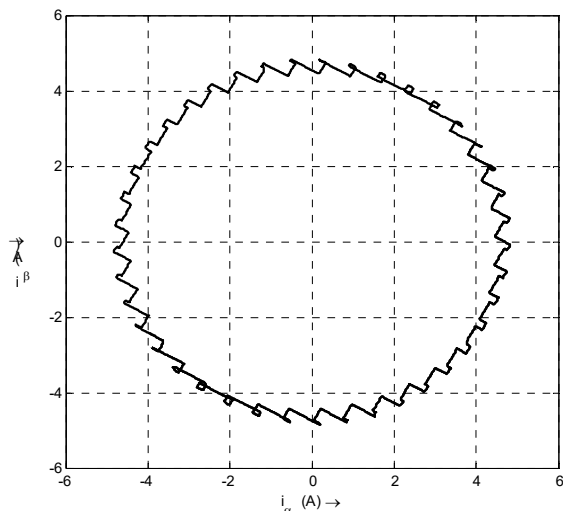

Fig. 10. Current space phasor trajectory for 60° phase shift $f = 30\text{Hz}$ and $r = 0,9$

By currents 60° shift was compensated backward current component which caused the elliptical shape of the trajectory of spatial phasor.

Weakening of the magnetic field can be partially compensated by an increase of supply voltage in area of the low frequencies. In any case, the machine performance drops below 50% of nominal power.

In Fig. 10 is shown the current space phasor for output frequency of $f = 30\text{Hz}$ and supply voltage control coefficient of $r = 0,9$.

Conclusion

In a presented contribution the trajectory of stator current space vector in a case one phases fault is discussed. There is shown is the possibility of two-phase operating with rotating magnetic flux in reduced machine performance.

Acknowledgment

The financial support of the Slovak Scientific Grant Agency under the contract N^o: VEGA-1/0121/15 is acknowledged.

Bibliography

[1]. Gaeta, A., Scelba, G., Consoli, A.: Modeling and Control of Three-Phase PMSMs under Open-Phase Fault. In: IEEE Energy Conversion Congress and Exposition, September 2011, pp:1684-1691

[2]. Elch-Heb, T., Hautier, J.P. : Remedial strategy for inverter-induction machine system faults using two-phase operation. In: European Conference on Power Electronics and Applications, pp.151-156, 1993

[3]. Záskalický, P., Dobrucký, B.: *Complex Fourier-series mathematical model of a three-phase inverter with Improved PWM output voltage control*; Elektronika ir Elektrotechnika, 2012m, Nr.7 (123), pp.65-68, Kaunas, KTU, Lithuania.

[4]. Ferková, Ž.,: *Two-Phase Asynchronous Motor - Simulation in ANSYS Maxwell and MATLAB-Simulink*; EDPE 2013: 17th International Conference on Electrical Drives and Power Electronics: 6th joint Croatian-Slovak Conference : October 2-4, 2013, Dubrovnik, Croatia

[5]. Záskalická M., Záskalický P., Beňová M., Mahmud A.R., Dobrucký B.: *Analysis of complex time function of converter output quantities using complex Fourier transform/series*; Communications-Scientific letters of the University of Žilina, pp. 23-30, vol.12, No.1 2010, Žilina.

[6]. Dobrucký B., Záskalický P., Kaščák S., Praženica M.: *Comparison of modified sinusoidal and space vector modulation for symmetrical two-phase induction motor under field oriented control*; IREMOS Int'l Review of Modelling and Simulation, 2012, vol. 5, no. 6, pp. 2445-2451.

[7]. Kaňuch J., Višnyí P.: *Control of two-phase induction motor using a conventional three-phase bridge inverter*; Maszyny Elektryczne - Zeszyty Problemowe, Katowice, Poland, Vol. 100, no. 4 (2013), p. 171-174.

[8]. Kaščák S., Záskalický P., Dobrucký B., Praženica M.: *Two-Phase Space Vector Modulation of FOC Controlled ASM Fed by 2-Phase VSI Inverter*; EPE-PEMC 2012 ECCE Europe", Novi Sad (RS), 4-6 Sept. 2012, pp. DS2c: 131-135.

[9]. Záskalický, P., Dobrucký, B., Praženica M.: *Modelling of Converter with PWM Output for Two-phase Motor Applications*; Elektronika ir Elektrotechnika, vol.20, Nr.1 2014, pp.25-28, Kaunas, KTU, Lithuania.

Author

Prof. Ing. Pavel Záskalický, PhD., is with Department of Electrical Engineering and Mechatronic, Faculty of Electrical Engineering and Informatics, Technical University of Košice, Letná 9, 04001 Košice, Slovakia.

(Email: pavel.zaskalicky@tuke.sk
tel.:+421 55 602 2272