

Signal conditioning for examination of shallow-water acoustic noise correlation properties

Mariusz RUDNICKI, Jacek MARSZAL

Gdansk University of Technology
Faculty of Electronics, Telecommunications and Informatics
Gabriela Narutowicza 11/12, 80-233 Gdańsk, Poland
mariusz.rudnicki@eti.pg.gda.pl

The article describes the process of signal conditioning for examination of acoustic noise correlation properties in shallow water. Knowledge of these properties is very important for the design processes of passive and active hydroacoustic systems. This paper focuses on the above issue from the point of view of passive sonar. In sonar systems, signal processing algorithms operate on both useful acoustic signals, and accompanying noise. Quantitative estimation of the correlation properties of acoustic noise enables an accurate determination of detection conditions. This will verify the validity of certain commonly used simplified models in simulations of hydroacoustic systems. The article presents how the measurement system was constructed, and the structure of files for storing measurement data. It describes the processing algorithm developed for the measured signal conditioning. Research results are presented and discussed.

Keywords: underwater acoustics, ambient noise, noise envelope, tetrahedral antenna

1. Introduction

The designing process of sonar systems requires consideration of many factors that directly or indirectly will affect the final product. Water-related factors are the most important, because sonars are operated in the water environment. The ambient acoustic noise is one of them. It determines the basic parameters such as range, detection probability, false alarm probability, distance measurement errors, estimation of target bearing, etc. [10, 11, 14]. Today's knowledge of the background noise of the sea is extensive, and in many designed applications is sufficient, but some designs must rely on simplified assumptions. They are made regarding statistical noise characteristics, and, in particular, the degree of noise correlation. One of the assumptions is that noise at the outputs of antenna elements, spaced

at half the wavelength, is uncorrelated [1]. The claim of uncorrelated noise is observed in the level of noise in the central beam of multibeam sonars, that is usually higher than in the deflected beams [13].

The article describes a method for preparing the results of noise measurements to help study their statistical properties and, in particular, the degree of time spatial correlation. In shallow seas and, especially, in coastal waters; in and around ports and transport routes natural noise background is difficult to study. Heavy ship traffic is the source of signals that are emitted by the propellers and hull-related turbulences, which distort the image of natural noise [5, 7, 8]. The article aims to eliminate the modulation of the noise amplitude caused by the propeller's rotary movement, propulsion machinery, auxiliary machinery and flow noise. The above modulation is commonly used in passive sonar for detection of low frequency ship noise by the DEMON algorithm (Detection of Envelope Modulation on Noise) [12].

2. Data acquisition system

Measurement data used in this work were made available by the Department of Hydroacoustics of the Polish Naval Academy, Gdynia. The team designed and built an original measurement system. It consists of a specialist antenna built on the basis of a regular tetrahedron, and measurement equipment by National Instruments [2, 3, 4, 9]. Sampling frequency is equal to 51.2 kHz for each channel. The design of the antenna is shown in Fig.1. The measurement system's antenna consists of four hydrophones placed in the corners of the regular tetrahedron with edge length $d = 0.25$ m. This particular antenna configuration allows one to study acoustic noise time spatial correlation properties in both horizontal and vertical planes. As well as carrying the hydrophones, the antenna includes sensors that allow determination of different parameters, such as roll, pitch and heading – antenna position relative to the North. During the measurements the antenna was placed on the bottom of the Gulf of Gdansk, near the Gdynia harbour. This place is an excellent example of a shallow water region.

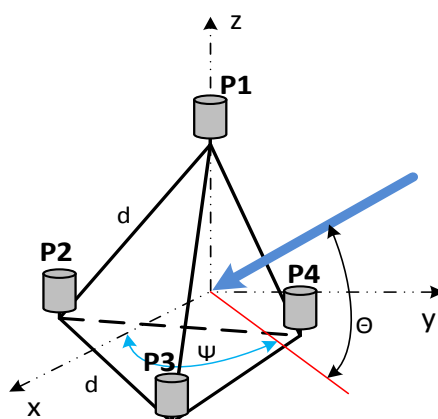

Fig. 1. Tetrahedral antenna of the data acquisition system.

3. Data pre-processing

As mentioned above, measurement data is stored in contextual files containing a variety of information, with a user-defined method of saving [15]. The purpose of pre-processing was to separate noise measurement data from other data. A script was created in the LabVIEW environment designed to synchronise signals coming from all hydrophones, a feature which is critical for determining correlation. Fig. 2 shows a part of the block diagram of the script that relates to a single channel.

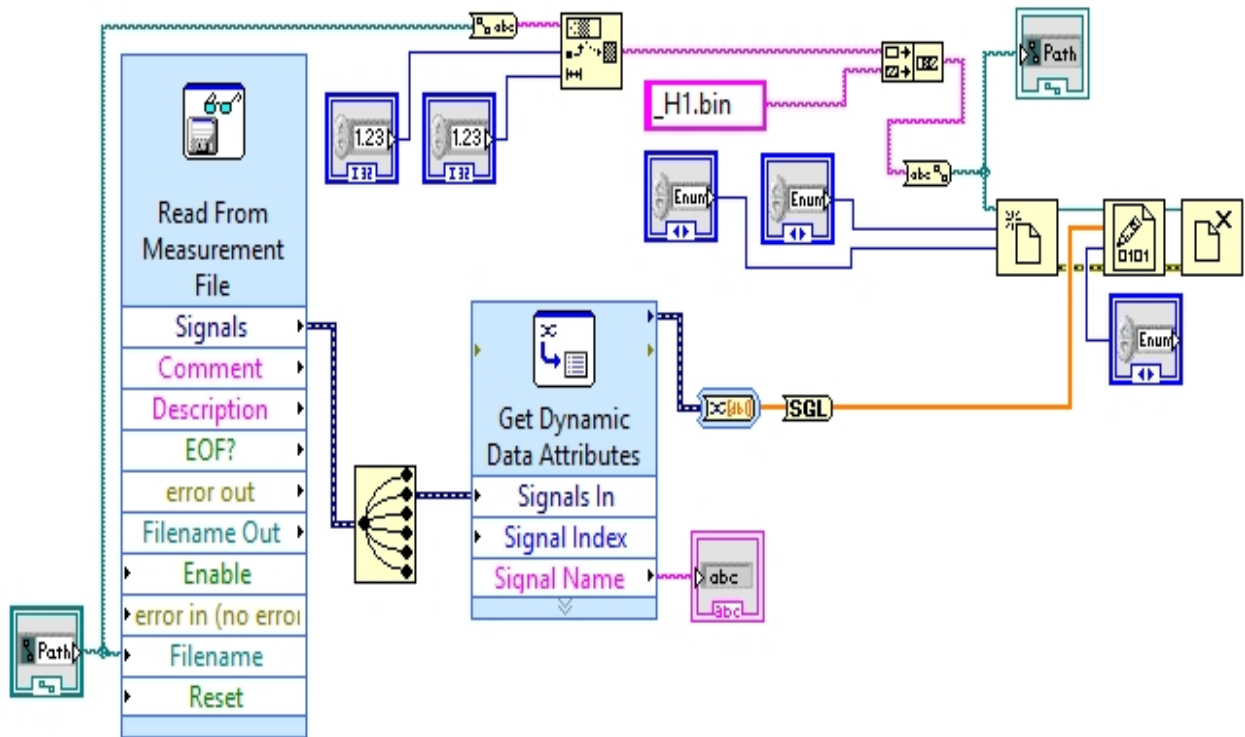

Fig. 2. Block diagram of the pre-processing algorithm in LabVIEW environment.

The operations described with the above algorithm are repeated for all channels, as a result we obtain four binary files containing measurement data from four hydrophones. Once separated, samples of the signals are saved as floating-point single precision data. When the data is prepared using the above method, it can be further processed.

4. Noise envelope elimination

The proposed by the authors Cut Noise Envelope (CUTE) algorithm was designed especially for examination of shallow-water acoustic noise correlation properties. The objective of the CUTE algorithm is elimination of the background noise envelope generated by low-frequency interfering noise of the moving propellers of ships. The algorithm proposed in this article is partially based on the DEMON algorithm. Fig.3 shows the algorithm's block diagram.

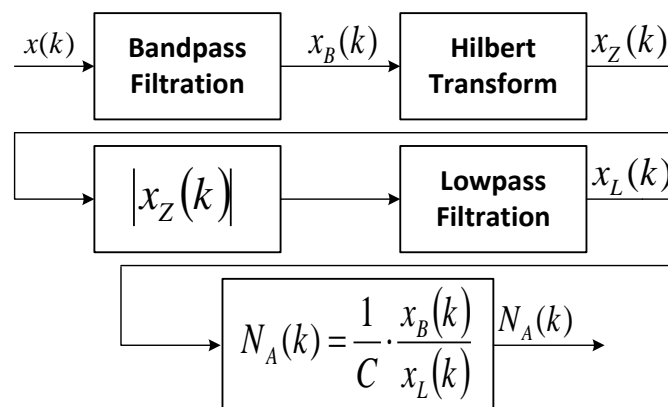

Fig. 3. Block diagram of the CUTE algorithm.

Signal $x(k)$ received by passive antenna is described by the following formula:

$$x(k) = a(k) \cdot n(k) + w(k) \quad (1)$$

where $a(k)$ is modulation envelope, $n(k)$ is a modulated broadband ambient noise signal, and $w(k)$ is a non-modulated broadband noise signal [6].

CUTE algorithm consists of several signal processing stages. The first stage involves narrow bandpass filtration with the frequency range matching the specific needs. The result is narrowband noise $x_B(k)$ for every spectra line from filtered band, described by the following simplified formula:

$$x_B(k) \cong [A + a(k)] \cos(j\omega_S k) \quad (2)$$

where ω_S is frequency of the spectral line.

The narrow band signal $x_B(n)$ is passed on to Hilbert transform with pulse response $h(k)$ [13]. At the transformer's output a complex signal appears described with this relation:

$$x_Z(k) = x_B(k) + jh(k) * x_B(k) \quad (3)$$

where $h(k) = \frac{1}{\pi \cdot k}$, and $*$ - denotes the convolution.

For a very narrow band of noise, the signal is similar to an analytical signal in this form:

$$x_Z(k) \cong [A + a(k)] \exp(j\omega_S k + \varphi_S) \quad (4)$$

where $a(k)$ is the noise envelope to be established, ω_S - frequency of spectral line, and φ_S - the phase.

Subsequent signal processing stages are designed to detect the noise envelope $a(k)$. This is done by determining signal module $x_Z(k)$ and low-pass filtering. Fig. 4 shows the results of the subsequent signal processing stages.

The signal $x_L(k)$ at the output of lowpass filter may be approximately described by the formula:

$$x_L(k) \cong C \cdot [A + a(k)] \quad (5)$$

The final stage of input data processing is to remove the envelope from the narrowband signal, the result of preliminary bandpass filtering. The process is described with the following formula:

$$N_A(k) \cong \frac{1}{C} \cdot \frac{x_B(k)}{x_L(k)} \quad (6)$$

where $N_A(k)$ is signal samples after removing noise envelope, $x_B(k)$ – signal samples after initial bandpass filtering, $x_L(k)$ – signal samples of noise envelope after lowpass filtering, C – a normalization factor.

After the division, we obtain normalized noise without an envelope which was caused by modulating the revolutions of the propeller. Figure 5 shows this effect for signals shown in Fig. 4.

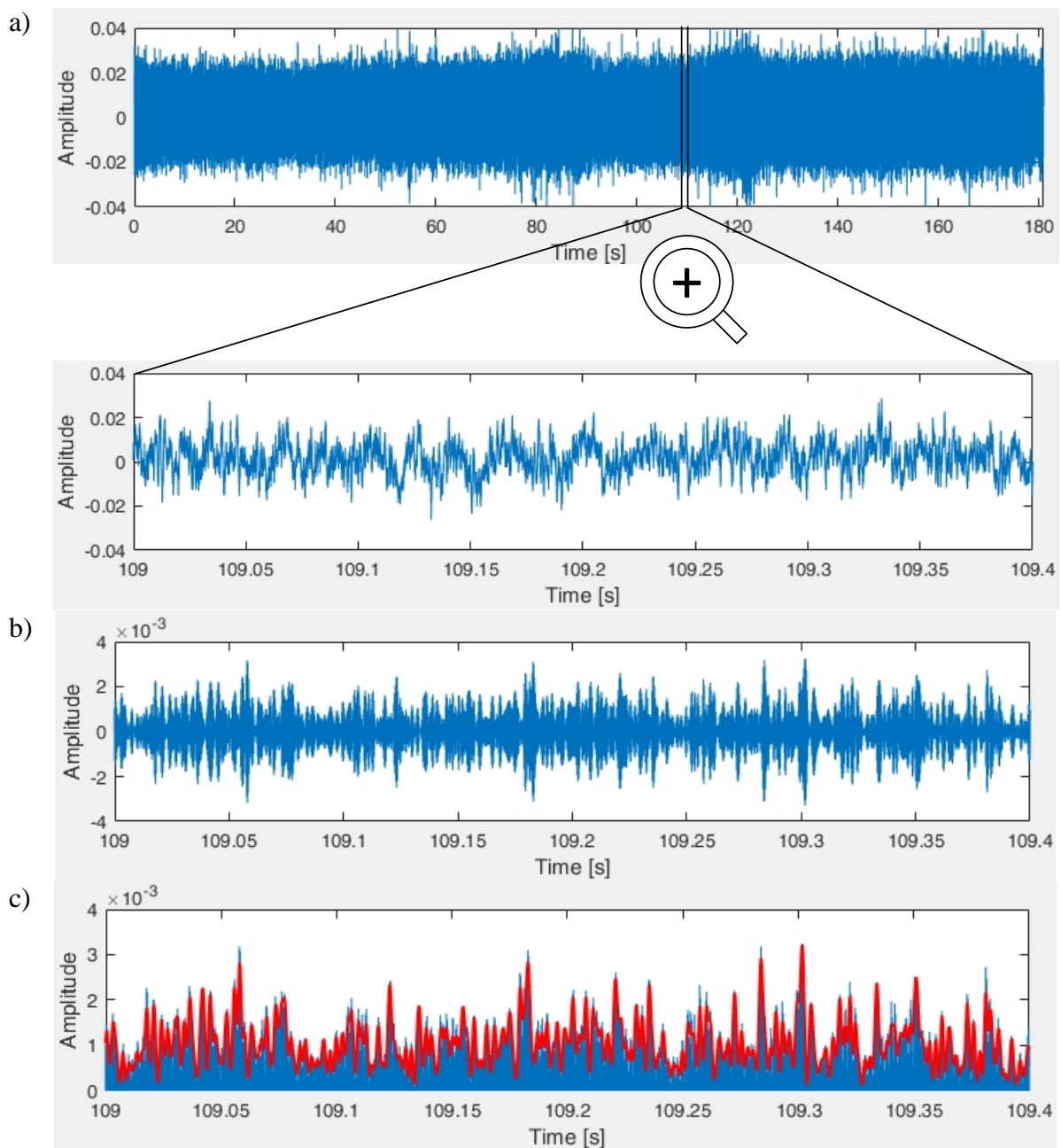

Fig. 4. The measured signal and its selected portion a), narrow band signal after band-pass filtering b), the narrow band noise (blue) and its envelope after lowpass filtration (red) c).

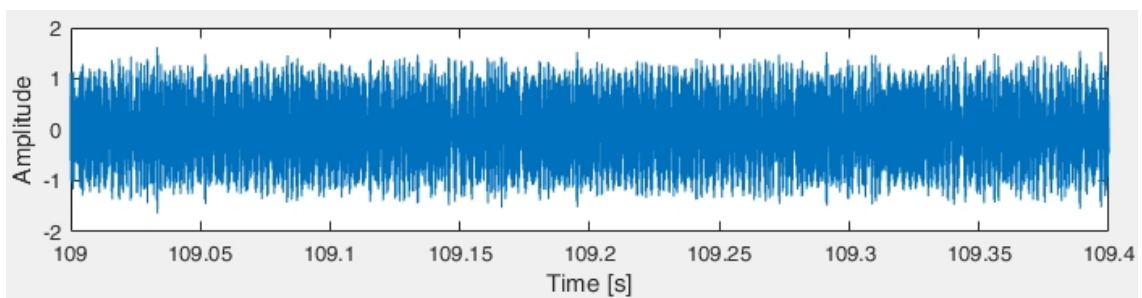

Fig. 5. Ambient noise after envelope removal.

It should be noted that the resulting noise signal is normalized. Because of this, the information about its amplitude is lost. On the other hand, the amplitude properties of analysed signal are irrelevant for the studies of its correlation properties.

5. Conclusion

To summarise, in the case of signals generated by passing ships, the CUTE algorithm helps to remove the envelope signal from a medium's measured signal in a selected frequency band. Such a signal can be treated as a pure representation of ambient noise in a specific frequency range. Further work will focus on selecting the filter bandwidth to make sure that the results represent ambient noise as accurately as possible in a selected frequency range. As the work continues, the signals will be used to study the correlation properties of acoustic noise in shallow water.

References

- [1] W. S. Burdic, *Underwater acoustic system analysis*, Prentice-Hall, INC., p. 214-219, p. 297-318, Englewood Cliffs, 1984.
- [2] I. Gloza, *Identification Methods of Underwater Noise Sources Generated by Small Ships*, *Acta Physica Polonica A*, 119, 6A, p. 961-965, 2011.
- [3] I. Gloza, K. Buszman, *The Multi-Influence Passive Module for Underwater Environment Monitoring*, *Hydroacoustics*, 14, p. 47-54, Gdansk, 2011.
- [4] I. Gloza, K. Buszman, K. Listewnik, *The Passive Module for Underwater Environment Monitoring*, *Proceedings of the 10th European Conference on Underwater Acoustics*, p. 1787-1793, Istanbul, 2010.
- [5] G. Grelowska, E. Kozaczka, W. Szymczak, *Underwater Noise Generated by Small Ships in the Shallow Sea*, *Archives of Acoustics*, 38, 3, p. 351-356, Warszawa, 2013.
- [6] I. Kirsteins, P. Clark, L. Atlas, *Maximum likelihood estimation of propeller noise modulation characteristics*, *Proceedings: 4th International Conference and Exhibition on Underwater Acoustic Measurements: Technologies & Results*, Kos Island, 2011.
- [7] E. Kozaczka, G. Grelowska, *Shipping low frequency noise and its propagation in shallow water*, *Acta Physica Polonica A*, 119, 6A, p. 1009-1012, 2011.
- [8] E. Kozaczka, G. Grelowska, *Shipping noise*, *Archives of Acoustics*, 29, 2, p. 169-176, Warszawa, 2004.
- [9] K. Listewnik, *Experimental Investigation of Hydroacoustic Multi-Sensor Array in Water Tank*, *Hydroacoustics*, 14, p. 127-134, Gdansk, 2011.
- [10] J. Marszal, *Experimental Study of Silent Sonar*, *Archives of Acoustics*, 39, 1, p. 103-115, Warszawa, 2014.
- [11] J. Marszal, R. Salamon, *Distance Measurement Errors, in Silent FM-CW Sonar with match Filtering*, *Metrology and Measurement Systems*, XIX, 2, p. 321-332, 2012.
- [12] Natanael Nunes de Moura, Eduardo Simas Filho and José Manoel de Seixas, *Independent Component Analysis for Passive Sonar Signal Processing*, *Advances in Sonar Technology*, Sergio Rui Silva (Ed.), InTech, 2009.
- [13] R. Salamon, *Systemy hydrolokacyjne*, Gdańskie Towarzystwo Naukowe, Gdańsk, 2006
- [14] A. D. Waite, *Sonar for Practising Engineers*, Third Edition, John Wiley & Sons, LTD., Chichester, 2002.
- [15] The NI TDMS File Format, <http://www.ni.com/white-paper/3727/en/>, National Instruments, 2015.