

Anna JANICKA<sup>1</sup>

## IN-VEHICLE TOXICITY MEASUREMENTS: IN-VITRO TESTS AS A NEW METHOD OF TOXICOLOGICAL ESTIMATION OF CAR CABIN ATMOSPHERE

### TOKSYCZNOŚĆ WNĘTRZA POJAZDU: TESTY IN VITRO JAKO NOWA METODA OCENY TOKSYKOLOGICZNEJ POWIETRZA WEWNĄTRZ KABINY POJAZDU

**Abstract:** In the article the difficult problem of mixtures toxicity has been discussed. The problem is very important in aspect of human life environment especially indoor air quality. A vehicle interior is a specific environment where levels of volatile toxic organic compounds are particularly high. The method of gaseous mixtures toxicity estimation based on in-vitro tests has been presented in application for vehicle cabin interior and compare with the popular toxicity indicators (relative toxicity coefficients). The results of the method application in brand new passenger vehicles (in parking conditions) are presented. The results were correlated with volatile organic compounds concentration in vehicles interior (method: gas chromatography).

**Keywords:** vehicle interior, volatile organic compounds, indoor measurements, toxicity

#### Introduction

Vehicle cabin contributes specific environment of human existence where the level of *volatile organic compounds* (VOCs) concentration in air can be even few times higher than outside [1, 2]. The main exposure route of those substances is inhalation, which accounts for 99% of the total exposure of the general population. The health effects of toxic volatile compounds are well documented: acute (short-term) inhalation exposure of humans to benzene may cause drowsiness, dizziness, headaches, as well as eye, skin, and respiratory tract irritation, and, at high levels, unconsciousness. Chronic (long-term) inhalation exposure has caused various disorders in the blood, including reduced numbers of red blood cells, aplastic anemia, and even leukemia [1].

The methods of investigation of substance toxic activity can be general divided on [2]:

- estimation of substance toxicity based on relation between chemical structure of substance and its biological activity (new direction of toxicology science),
- investigation of substance toxicity based on tests on animals (the most popular method),
- alternative methods based on rule 3R (replacement, reduction, refinement) which aim is to eliminate or reduce of animal suffer.

For toxicity estimation and analysis of the group of substances usually data for one representative and common compound occurring in environment are used (*ie* benzene for VOCs group). The intensity of mutagenic, carcinogenic, irritant or sensitize activity of other compounds from the group is counted in relation to the representative compound. This method can be used to determine *Relative Toxicity Coefficient* (RTC) (mutagenic,

---

<sup>1</sup> Institute of Machine Design and Operation, Faculty of Mechanical Engineering, Wrocław University of Technology, ul. Wybrzeże Wyspiańskiego 27, 50-370 Wrocław, phone 71 347 79 18, email: anna.janicka@pwr.wroc.pl

carcinogenic, irritant or sensitize) for all substances from the group. Because of discussible, law-based toxicity equivalent factors or relevant toxicity coefficients measures of mixtures toxicity the direct methods of toxicity estimation are needed to be developed [3]. The example is an *in-vitro* method which has been proposed and developed by the article author.

## Methodology

The indoor air samples was up-taken from two new (month after manufacture date) different brands vehicles interior: Japanese (vehicle A) and German (vehicle B) production, same class, similar equipment.

The samples of inner air were uptaken by active coal tubes (for chromatography) and based on the ISO/DIS 12219-1draft international standard [d] by special flasks with human lung cells previously prepared in Institute of Immunology and Experimental Therapy of Polish Academy of Science laboratories.

The sampler was put into popular, brand new, passenger-vehicle interior and plugged-in to aspirator (ASP II) the localization of system inlet is presented on Figure 1 and exposed for 4 hours.

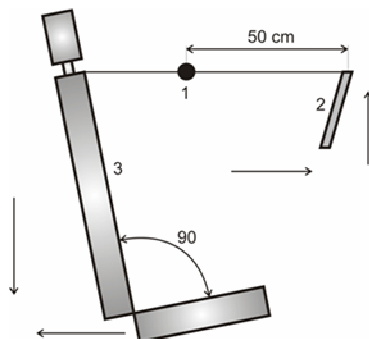

Fig. 1. Schematic arrangement of the sampling position in test vehicle: 1 - sampling point, 2 - steering wheel, 3 - seat with head rest

After sampling procedure the samplers consist standardized cell-culture system (human cell line A549 was analyzed. Cell growth, cell morphology and cell viability were used as parameters to determine the cytotoxicity of vehicle interior atmosphere. The measure the lethality effect on cells was determined spectrophotometrically with the use of a mitochondrial enzyme activity assay for mitochondrial succinat dehydrogenase activity by 3-(4,5-dimethylthiazol-2-yl)-2,5-diphenyltetrazolium bromide (MTT assay).

The A549 cells are maintained in Dulbecco's modified Eagle's minimum essential medium (DMEM), and the L929 cells were kept in Eagle's supplemented with 10% calf serum (c.s), 2 mM L-glutamine, antibiotics (100 U/cm<sup>3</sup> penicillin and 100 lg/cm<sup>3</sup> streptomycin).

According to Polish standard (PN-EN ISO 10993-5) cytotoxicity is investigated on two cells lines. Measuring in vitro growth of mouse fibroblast L929 and human A549 cell line.

For cytotoxicity test, the cells are seeded in the 24-well plates (Nunc) of 1 cm<sup>3</sup> at density of 2x10<sup>5</sup> cells/cm<sup>3</sup> in the culture medium Eagle's or DMEM with 2% calf serum, penicillin and streptomycin is deposited into each well. Samples of the tested samples contain VOCs are added to prepared cells, which are then incubated for 24, 48 and 72 h at 37°C in the atmosphere of 5% CO<sub>2</sub> in air.

VOC's samples were up taken by tubes with active coal (SKC lot 2000). The analysis was done according to Polish standard: PN-EN ISO 16017-1:2006. The qualitative and quantitative analysis was proceed on Varian 450 GC gas chromatograph with FID detector and capillary column was used for quantity and quality analysis. Carbon disulfide (CS<sub>2</sub>) was used for VOCs extraction from active coal. The chromatography conditions were: column temperature (110°C), dozers (150°C) and detectors (250°C).

Relative Toxicity Coefficients (RTC) were calculated for most characteristic in-vehicle compounds and VOCs group based on to two Polish standards of Maximum Allowed Concentrations: for indoor environment and for workplaces according to the Table 1.

Table 1

Relative Toxicity Coefficients for chosen compounds and VOCs groups

Chemicals name	Indoor Maximum Allowed Concentration (spaces A category) (IMAC) [ $\mu\text{g}/\text{m}^3$ ] [y]	Relative Toxicity Coefficient (RTC) according to IMAC (RTC-IMAC)	Maximum Allowed Concentration for Workplaces [ $\text{mg}/\text{m}^3$ ] (MACW) [x]	Relative Toxicity Coefficient (RTC) according to MACW (RTC-MACW)
Toluene	200	0.05	100	0.016
Benzene	10	1	1.6	1
Ethylbenzene	100	0.1	100	0.016
Xylene (isomers)	100	0.1	100	0.016
GROUPS				
Aromatic HC	66	0.15	49	0.033
Alifatic HC	250	0.04	678	0.002
Other VOCs	90	0.11	170	0.009
Total VOCs	135	0.07	229	0.007

## Results

The results were presented in tables and figures below.

Table 2

*In-vitro* testes results

Sample description	New vehicle 1 (brand a)			New vehicle 2 (brand b)		
	Number of cells <i>N</i> (72 h)	$\alpha =$ $N_i/N_{control}$	Dead cells [%]	Number of cells <i>N</i> (72 h)	$\alpha =$ $N_i/N_{control}$	Dead cells [%]
Control sample	94 000 000	1.00	0	240 000 000	1.00	0
Interior 1	40 000 000	2.35	2	8 000 000	30.00	26
Interior 2	32 000 000	2.94	10	3 200 000	75.00	75
Interior 3	38 000 000	2.47	6	4 500 000	53.33	50
Interior average	37 000 000	2.56	6	5 200 000	45.86	50
Background	81 000 000	1.16	0	190 000 000	1.26	0

In Table 2 the results of *in-vitro* tests toxicity are presented as number of dead cells after 72 hours of cultivation after exposition on vehicle interior atmosphere and number of cells in control sample to number of exposed cells ( $\alpha$ ) after 72 h.

In Figure 2 the comparison of the *in-vitro* tests results for both vehicles interiors is presented.

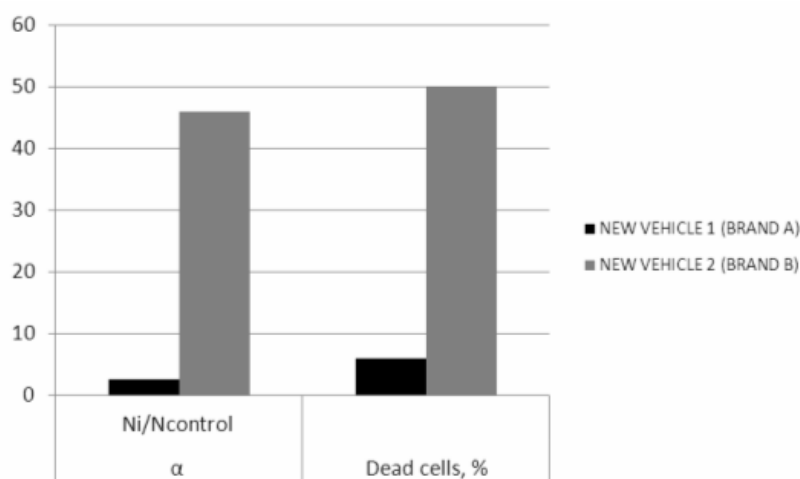

Fig. 2. Comparison of the *in-vitro* tests results for both vehicles interiors

*In vitro* tests indicate that the interior of vehicle 2 is almost 10 times more toxic than vehicle 1 for human lung cells. The atmosphere inside the second vehicle cabin after 4 hours of direct exposure caused a lethal effect for half the cell line and inhibited cell growth in almost 50% in comparison with the control sample. In the case of vehicle no. 1, the exposure caused the death of 6% of the culture and almost 3% inhibition of the human lung cell line growth.

In Table 3 the results of chromatographic analysis and computational results of toxicity indicators are presented.

Table 3

Relative Toxicity Coefficients for chosen compounds and VOCs groups

	New vehicle 1 (brand a)			New vehicle 2 (brand b)		
	Average concentration (Ci) [ $\mu\text{g}/\text{m}^3$ ]	RTC - IMAC	RTC - MACW	Average concentration (Ci) [ $\mu\text{g}/\text{m}^3$ ]	RTC - IMAC	RTC - MACW
Toluene	29.5	1.5	0.5	249.2	12.5	4.0
Benzene	39.3	39.3	39.3	114.8	114.8	114.8
Ethylbenzene	8.4	0.8	0.1	411.3	41.1	6.6
Xylene (isomers)	17.3	1.7	0.3	26.5	2.6	0.4
Groups						
Aromatic HC	188.7	28.8	6.2	608.4	92.8	19.8
Alifatic HC	1303.1	52.1	3.1	507.8	20.3	1.2
Other VOCs	185.4	20.6	1.7	275.8	30.6	2.6
Total VOCs	1677.2	124.1	11.7	1641.2	121.4	11.4

In Figures 3 to 5 the concentrations of VOCs groups and Relative Toxicity Coefficient (RTC) according to IMAC and MACW are compared for both vehicles.

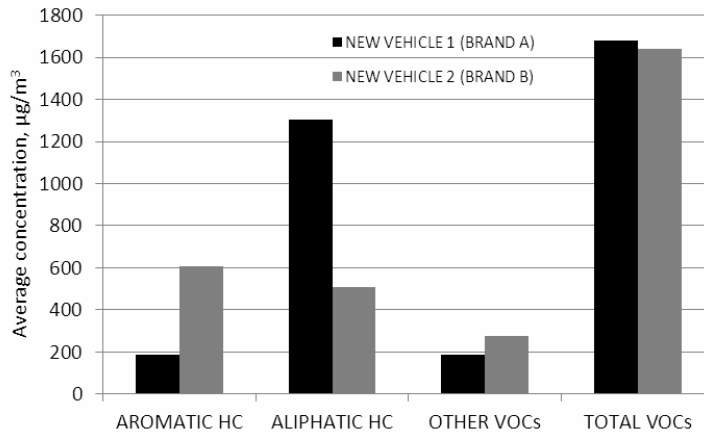

Fig. 3. Average concentration of VOCs groups in cabin air [ $\mu\text{g}/\text{m}^3$ ]

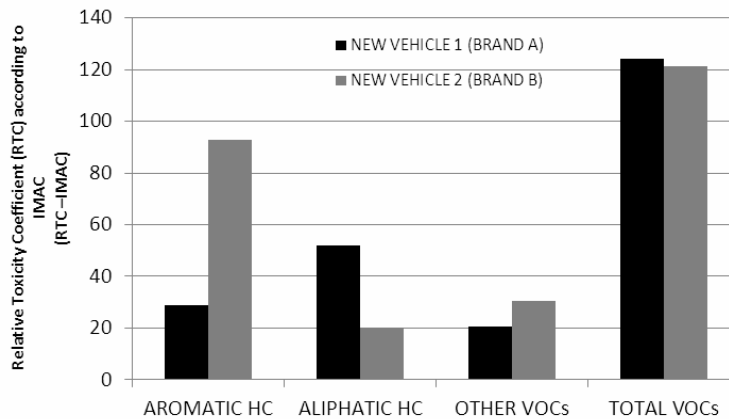

Fig. 4. Relative Toxicity Coefficient (RTC) according to IMAC

The difference between total VOCs concentrations in both vehicles is insignificant. The differences in VOCs group share are visible. In case of vehicle no 2 concentration of aromatic hydrocarbons is two times higher than in vehicle 2 interior atmosphere.

The computational toxicity indicators show the significant differences between using different bases of calculation methods (MAC for indoor atmosphere and MAC for workplaces).

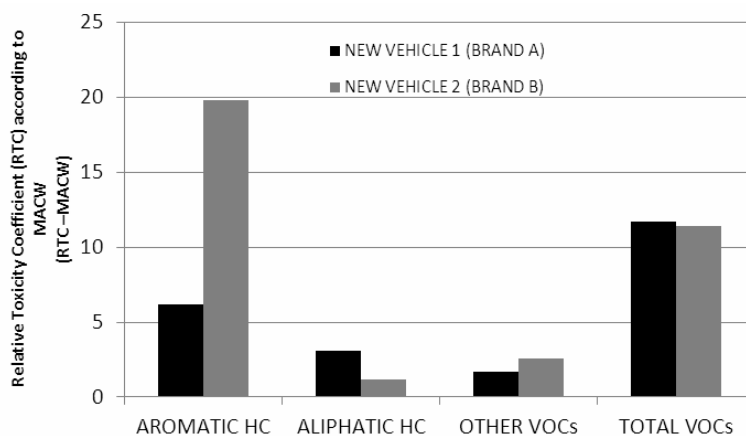

Fig. 5. Relative Toxicity Coefficient (RTC) according to IMAC

## Summary

Gaseous mixtures toxicity is complex and complicated problem for evaluation. Because of discussible, law-based computational toxicity indicators measures of mixtures toxicity the direct methods of toxicity estimation are needed to be developed. The example is the method which has been proposed and developed by the author article. Despite the fact that the total VOCs concentration is almost the same in cabin of both cars, proposed by the author *in vitro* tests on human lung cells indicates that interiors of two new vehicles (month after manufacture date), same class, similar equipment can be 10 times more toxic. It also proof that RTC methods need to be evaluated. The RTC calculations based on two different standards shows that the method is discussible but proofed toxicity determined effect for aromatic hydrocarbons. Compared with the *in vitro* tests it shows that very complicated effects of synergism can strongly impact on real toxic effect of volatile toxins on human respiratory system.

## References

- [1] Zawiałak M. Numerical modeling of vehicle interior in aspect of human exposure on volatile organic compounds. *Polish J Environ Studies*. 2012;21(5A):454-458.
- [2] Sarigiannis DA, Karakitsiosa SP, Gottic A, Liakosa IL, Katsoyiannisa A Exposure to major volatile organic compounds and carbonyls in European indoor environments and associated health risk. *Environ Int*. 2011;37(4):743-765. <http://dx.doi.org/10.1016/j.envint.2011.01.005>.
- [3] Janicka A. Method of toxicity estimation of gaseous mixtures emitted from different emission sources. *Polish J Environ Studies*. 2012;21(5A):134-139.
- [4] ISO/DIS 12219 (2011): Indoor air of road vehicles: Whole vehicle test chamber - Specification and method for the determination of volatile organic compounds in cabin interiors.
- [5] Rozporządzenie Ministra Pracy i Polityki Społecznej z dnia 29 listopada 2002 r. w sprawie najwyższych dopuszczalnych stężeń i natężeń czynników szkodliwych dla zdrowia w środowisku pracy.
- [6] Zarządzenie Ministra Zdrowia i Opieki Społecznej z dnia 12 marca 1996r. w sprawie najwyższych dopuszczalnych stężeń i natężeń czynników szkodliwych dla zdrowia, wydzielanych przez materiały budowlane, urządzenia i elementy wyposażenia w pomieszczeniach przeznaczonych na pobyt ludzi.

## **TOKSYCZNOŚĆ WNĘTRZA POJAZDU: TESTY IN VITRO JAKO NOWA METODA OCENY TOKSYKOLOGICZNEJ POWIETRZA WEWNĄTRZ KABINY POJAZDU**

Instytut Konstrukcji i Eksploatacji Maszyn, Wydział Mechaniczny, Politechnika Wroclawska

**Abstrakt:** W artykule podjęto dyskusję nad trudnym problemem oceny toksyczności mieszanin gazowych. Problem jest istotny szczególnie w aspekcie jakości powietrza w środowisku przebywania człowieka, a zwłaszcza w pomieszczeniach zamkniętych. Takim środowiskiem jest wnętrze kabiny pojazdu, w którym stężenia związków toksycznych są szczególnie wysokie. W artykule przedstawiono metodę oceny toksyczności mieszanin gazowych opartą o badania in vitro w kabinach pojazdów jako jedną z możliwości jej aplikacji. Zaprezentowano wyniki badań mających na celu ocenę toksykologiczną wnętrza różnego typu nowych pojazdów samochodowych w warunkach parkingowych. Wyniki badań zestawiono z pomiarem stężeń lotnych związków organicznych (metoda chromatografii gazowej z detekcją mas).

**Słowa kluczowe:** wnętrze pojazdu, lotne związki organiczne, pomiary jakości powietrza wewnętrznego, toksyczność

