

## **SULPHUR CONCRETE’S TECHNOLOGY AND ITS APPLICATION TO THE BUILDING INDUSTRY**

***Natalia Ciak<sup>1</sup>, Jolanta Harasymiuk<sup>2</sup>***

<sup>1</sup> The Chair of Building Construction and Building Physics

<sup>2</sup> The Chair of Engineering Materials and Building Processes  
University of Warmia and Mazury in Olsztyn

Received 21 August 2013; accepted 21 November 2013; available on line 22 November 2013

**Key words:** technology, sulphur concrete, properties and application, goods modified with sulphur, extenders.

### **Abstract**

This article is a scientific – review piece of work which purpose is to popularize the common knowledge of sulphur concrete – the material that has become more and more popular not only in countries with established market economy. In the article there are presented key phases of scientific studies concerning technology of the sulphur concrete, concrete modified with sulphur and its application in building industry. There is also presented methodology of sample preparations, technology of production and its main technical properties.

### **Introduction**

Science and practice have been always searching for new materials and solutions characterised by durability and good strength properties that would become an alternative for materials demanding huge energetic costs. Very often we come to the conclusion that the “new one” is a modern version of well known “old one”. That is what happens in the case of the sulphur concrete. It was in the previous century that many researchers (FARAŃSKI 1999, LOOV, VROOM, WARD 1974, MALHOTRA 1979, ORŁOWSKI 1992) proved that in order to obtain composite resistant to chemical aggression, the sulphur can be used as a bond. This article is to draw the attention to the most distinguished advantages and disadvantages of this material, its application and the technology of production assuring designed, required properties.

---

\* Correspondence: Natalia Ciak, Katedra Budownictwa Ogólnego i Fizyki Budowli, ul. Heweliusza 4, 10-724 Olsztyn, phone: 48 89 523 45 76, e-mail: n.ciak@uwm.edu.pl

## Main features of the sulphur concrete

Growing interests in sulphur usefulness as a bond in the sulphur concrete is led by huge amount of this raw material (it occurs as a natural raw material and is also created as a waste from the fuel desulphurisation process), and by proved advantages of created composite (CZARNECKI, WYSOKIŃSKI 1994, KUŚ, ROGAL 2004, Patent PL *Sposób utylizacji niebezpiecznych odpadów, zwłaszcza popiołów ze spalarni* 2003). The advantages include e.g.:

- relatively high strength obtained in short time,
- resistance to most of the aggressive agents,
- waterproof,
- utilisation possibility of most of the harmful substances including radioactive wastes (Patent PL *Sposób utylizacji niebezpiecznych odpadów, zwłaszcza popiołów ze spalarni* 2003),
- recycling possibility.

In spite of many advantages of the sulphur concrete, it should not be treated as a substitute for cement concrete, but in particular cases as an alternative. Such an approach can be justified by some of the faults of the material (CZARNECKI, WYSOKIŃSKI 1994) such as:

- high energy consumption during the production process,
- limited thermal resistance (the sulphur concrete is a thermoplastic material),
- a need for stable, high temperature during the production process.

## Development of the sulphur concrete's technology

The interests in concrete and materials modified with sulphur, its properties and the technology have been heading towards two directions. The first one concentrated on sulphur bonds, mastics, and concrete based on sulphur as a thermoplastic bonding material. The second one was devoted to the use of melted sulphur for saturation of cement concrete manufactures in order to enhance their physical and mechanical properties, but mostly to increase its corrosive durability. All of the actions focused into these two directions can be divided into four stages.

The first stage, from the second half of XIX century till the forties of XX century, included the study of properties of the mastics and concrete modified with sulphur and their reasonable application in the building industry. Unfortunately high costs of sulphur these days was not conducive for scientific and practical publications of this subject.

In the second stage, from the forties to the early seventies of XX century,

there was a commercial idea created of the sulphur concrete applications. There were also intense researches conducted over the ways of improving the sulphur properties, that were based on the latest scientific publications about the chemistry of the sulphur (development of the inorganic chemistry of polymers). Simultaneously, industrial polymeric sulphur modification was introduced into various fields, what led to creating effective building materials using such technology. Research centres that were leading the way in the subject were located in the USA, Canada and Russia (former the Soviet Union).

Third stage, dated from the late seventies was characterised by putting into practice the production of building materials, especially concrete. Those days (1975) the *Sulfurcrete Products Inc.* company for the first time created the sulphur concrete. In the eighties sulphur concrete became one of the building materials used in construction of many parts of motorways and industrial floors that were built in the USA.

In the fourth stage, starting from the late nineties till now, production of the sulphur concrete, its improvements and composition patents are being created (Patent PL 197205, Patent PL *Sposób utylizacji niebezpiecznych odpadów, zwłaszcza popiołów ze spalarni* 2003, Patent RU 2154602, Patent RU 2166487, Patent RU 2167120, Patent RU 2239834, Patent USA 4256489) as well as technology of production used by different companies, usually located in the USA, Canada (*SULROCK, CHEMPRUF, SULPOL, STARCRETE*), Russia and Poland.

Since 1998, a company “SIARKOPOL” from Tarnobrzeg has started to put the usage of the sulphur concrete into building practice. Now a “MAR-BEL” company is using their own patented solutions for manufacturing composites such as: *SULCEM, SULTECH, SULBET* (MYSŁOWSKI 2005, RICHTER 2006).

## **Manufacturing and usage of the sulphur concrete**

Process of the sulphur concrete manufacture is based on the “hot” technology. In which all the mixed components are heated until 140–150°C. The sulphur used in the sulphur concrete production can be mixed with any type of traditional aggregate. Dosage should be optimized according to practical criteria as well as the mechanical properties (GRACJA, VAZGUEZ, CARMONA 2004). Optimal amount for sulphur mortar is about 30% of the bond while for the sulphur concrete is about 15% of the bond. The sulphur matrix with the percentage of mineral extender is 5% for mortar and 10% for concrete (on sulphur mass basis).

Mineral aggregate is very important in the sulphur concrete. The concrete mixture should consist of thick and fine aggregate as well as the extenders

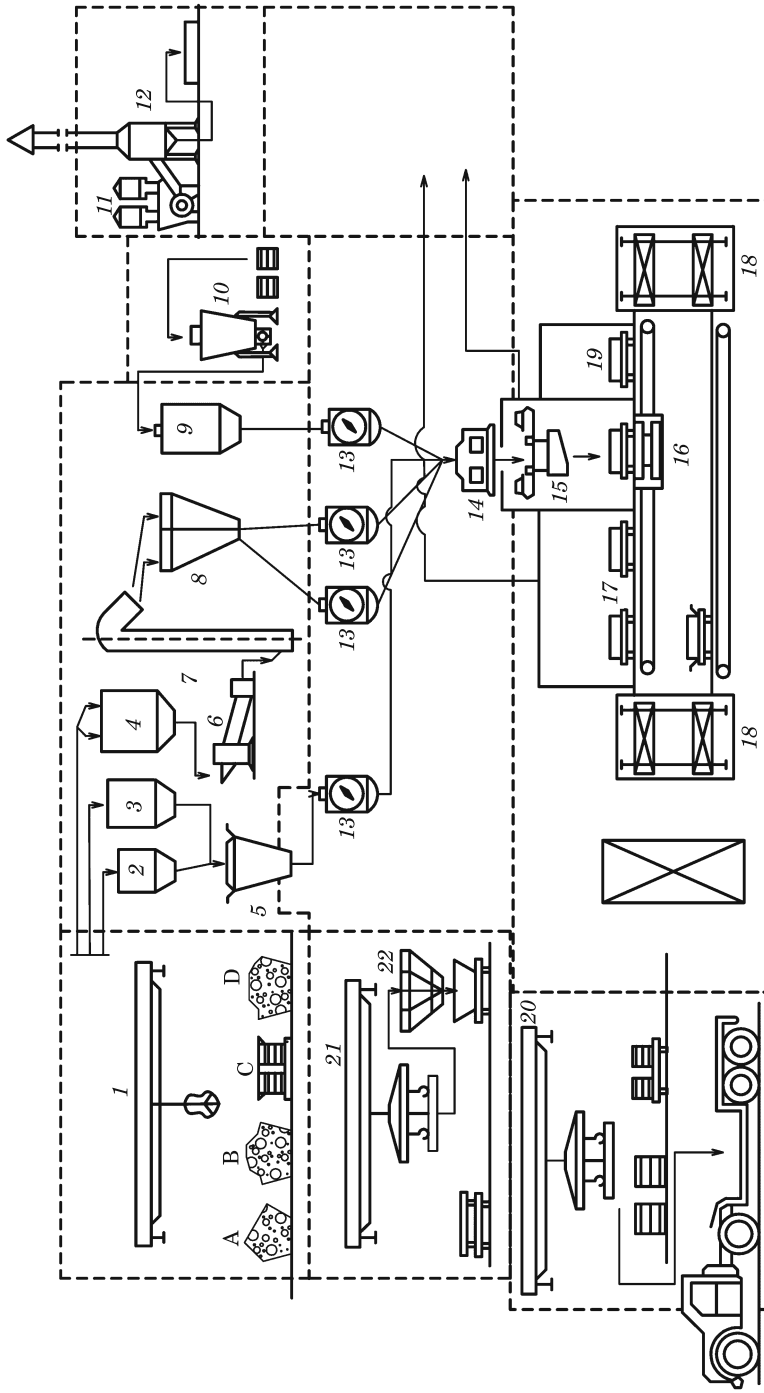

Fig. 1. Technological scheme for sulphur concrete manufactures production: A – gravel, B – sand, C – additives, D – sulphur, 1 – compounds storehouse, 2, 3, 4 – tanks (silos), 5 – sulphur modification reactor, 6 – rotary dryer, 7 – feeder, 8 – sand and gravel’s silo, 9 – extender’s silo, 10 – extender’s feeder, 11 – cyclone, 12 – filter, 13 – feeder, 14 – mixer with heater, 15 – forming device, 16 – vibration station, 17, 18 – mobile forms, 19 – chamber for heating up the forms, 20 – storehouse for finished manufactures, 21, 22 – recycling station

Source: CIAK (2007a).

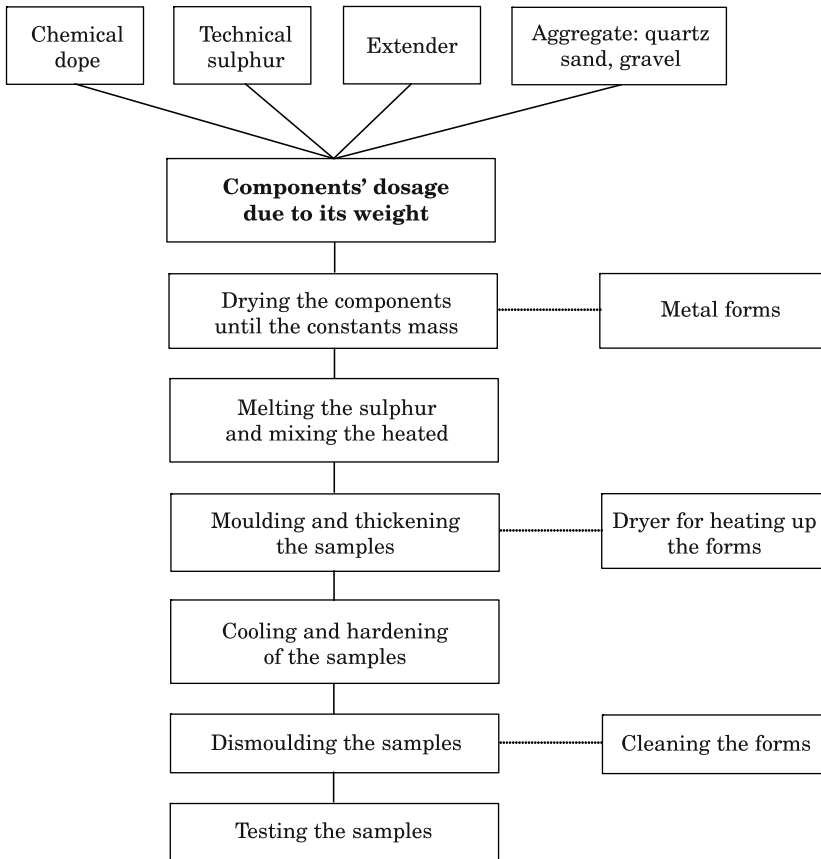

Fig. 2. Technological scheme of sulphur concrete sample preparation for laboratory usage  
Source: own researches.

(GILLOT, JORDAN, LOOV 1980). Gravel and other mineral materials bigger than 4 mm in diameter can be assumed as a thick aggregate while sand and other mineral materials in the range of 150  $\mu\text{m}$  to 4 mm will be assumed as a fine aggregate. The extenders can be in the shape of volatile ashes, quartz dust, minced chalk and others mineral materials smaller than 150  $\mu\text{m}$ . The extenders' presence reduces the pores, that emerge during the sulphur contraction where the sulphur due to the hardening process, changes its volume. One should notice that getting a proper, designed form of plastic mass is only possible when the mixture is characterised by defined plasticity adjusted by the exact amount of fine and thick aggregate and the extenders. Excessive amount of them usually leads to worsening the moulding process.

Process of sulphur concrete production is based on the sulphur's properties of changing its viscosity with the change of the temperature (in 119–122°C sulphur completely turns from the solid into the liquid).

The technology of the sulphur concrete is very similar to the technology of the asphalt concrete. The sulphur concrete production process is presented in the figure 1.

It consists of following steps:

- heating up the mixture until 150°C,
- melting of modified sulphur and mixing the components,
- moulding samples into metal moulds which were initially heated to the same temperature as the mixture,
- cooling the samples to the ambient temperature.

In University of Warmia and Mazury in Olsztyn there has been conducted researches of sulphur concrete's resistance to chemical and microbiological aggression. In order to prepare the sulphur concrete in a laboratory (scheme for preparation of samples process is presented in the Figure 2), there was constructed a reactor in which the samples were prepared (Fig. 3). The researches results proved usefulness of application of the sulphur concrete in

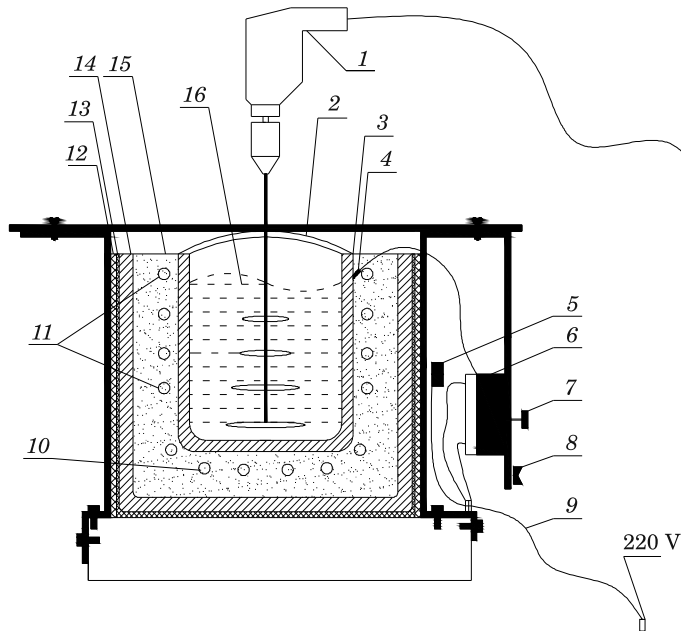

Fig. 3. Lab reactor scheme for sulphur bond and mastics preparation: 1 – mixer wit adjustable speed, 2 – heat-insulating cover, 3 – aluminium mixer, 4 – temperature meter, 5 – short circuit pin, 6 – thermostat, 7 – temperature controller, 8 – power switch, 9 – voltage 220 V, 10 – electrical spiral (1 pc.), 11 – electrical spiral (2 pcs.), 12 – thermal insulation in aluminium foil of 6 mm, 13 – asbestos sheet, 14 – metal container, 15 – fire insulation, 16 – sulphur

Source: own researches.

Table 1  
Comparison of averaged, selected properties of sulphur concrete and the cement concrete\*

Properties	Unit	Sulphur concrete	Cement concrete
Density	kg/m <sup>3</sup>	2400	2200
Compressive strength	MPa	60–115	15–60
Bending strength	MPa	10–16	6–7
Modulus of elasticity	GPa	35–50	25–28
Contraction	mm/m	0.5–1.0	0.6
Linear coefficient of thermal expansibility	10 <sup>-6</sup> /K	8–12	8–10
Porosity	%	1–4	9–15
Absorptivity	%	0–1	5
Frost resistance	cycles	500	50
Minimal period for forming an element	Hour	0.1–0.4	48
Minimal period for nominal strength	hours	2–24	28 days
Corrosive durability in aggressive surroundings	–	resistant	partly resistant
Bond content	%	10–15	20–30

\* Notice: In the sulphur concrete contraction occurs only during the hardening process and cooling the mixture within 2–24 hours.

Source: own researches on the basis of: CIAK (2007a,ń), and information data from MARBET®WIL company, for sulphur concrete SULTECH®.

building roads, drainage systems, industrial and harbour engineering, and agriculture. Comparison of selected sulphur concrete's features with the cement concrete's ones are presented in table 1.

On the basis of (Patent PL 197206, ŻAKIEWICZ 1996), the sulphur concrete can be used for anti-radiation protective shields.

The use of sulphur concrete for manufactures production gives an opportunity to create new, effective material solutions creating new standard in building elements. Among the most popular manufactures are:

- tanks for various substances, cesspits, drains;
- sewerage pipes, drainages, sewerage channels, weights for electric traction lines (MAĆKOWSKI 2009);
- telecommunications drains, elements reinforcing the wharf and harbour constructions; (CZARNECKI, WYSOKIŃSKI 1994);
- surfaces of landing strips, roadwork's' elements (SERUGA, SMAGA 2006).

As shown above, sulphur concrete can be applied both for non-reinforced elements (weights, channels, drainage elements) and for reinforced elements (tanks, plates). To the wide range of usage we can also add its usefulness in renovations works (coatings with fiber extenders) and restoration works (CIAK 2005, CZARNECKI, WYSOKIŃSKI 1994).



Fig. 4. Exemplary manufactures made with the sulphur concrete – photographs by Andrzej Drożdzał, present manufactures produced by Marbet-Wil Company: *a* – sulphur bond, *b* – sulphur concrete granulate consisting of harmful waste destabilised with the use of Sultech® technology, *c* – linear drainage AQUADREN® *d* – weights for electric traction lines, *e* – channel drainage S520, *f* – channel drainage S520 put along the railway tracks

In the figure 4 there are presented chosen manufactures made with the sulphur concrete.

Assessing the sulphur concrete by the mechanical and chemical properties and by comparing it to the cement concrete's properties one can state that the variety of the sulphur concrete usage is quite broad. What is more the production is almost waste less and the product itself can be recycled.



## Conclusions

The sulphur concrete are characterised by high resistance to biological and chemical corrosion. In some cases its mechanical and physical properties can even transcend the properties of traditional concrete so can it can be assumed as a better solution for some building constructions. It should be expected that the interests in the sulphur concrete and its development within next several years should not deteriorate.

## References

- BLASIAK I., ŁUSZCZYK L., ŻWIMK S., DOJKA M. 1988. *Zastosowanie siarki modyfikowanej do wyrobu betonów siarkowych*. Chemik, 41 (9): 243.
- CIĄK N. 2007a. *Analiz vlijania sostava židkikh agresivnykh sred na korrozionnuju stojkost' cementnykh betonom propitannykh rasplavom siery*. Stroitelstvo i tehnogennaja bezopasnost'. Sbornik naucznykh trudov. Vypusk 22 Symferopol, p. 50–53.
- CIĄK N. 2007b. *Chimiczeskaja i mikrobiologičeskaja stojkost' betonov, modifitsirovannykh sieroj*. Diss. Simferopol, p. 191.
- CZARNECKI L., WYSOKIŃSKI L. 1994. *Beton siarkowy – nowy materiał konstrukcyjny w budownictwie morskim*. Inżynieria Morska i Geotechnika, 5: 262–266.
- FARAŃSKI R.J. 1999. *Tworzywa siarkobetonowe*. Materiały Budowlane, 6: 78.
- GILLOT J.E., JORDAN I.J., LOOV R.E. 1980. *Sulphur concretes, mortars and the like*. United States Patent (4.188.230).
- GRACJA V., VAZGUEZ E., CARMONA S. 2004. *Utilization of by-produced sulfur for the manufacture of unmodified sulfur concrete*. International RILEM Conference on the Use of Recycled Materials in Buildings and Structures, International RILEM Conference on the Use of Recycled Materials in Buildings and Structures, RILEM PROCEEDINGS PRO; 1–2, 40: 1054–1066.
- KUŚ M., ROGAL S. 2004. *Zastosowanie przemysłowe siarkobetonu*. Autostrady, 3.
- LOOV R.E., VROOM A.H., WARD M.A. 1974. *Sulfur concrete-a new construction material*. PCI Journal/January-February, p. 86–95.
- MAĆKOWSKI R. 2005. *Zastosowania chemoodpornych betonów siarkowych*. Ochrona przed korozją, 4: 134–136.
- MALHOTRA V.M. 1979. *Sulphur Concrete and Sulphur Infiltrated Concrete*. Properties, Applications and Limitations, Canada Centre for Mineral and Energy Technology, Mineral Sciences in Ottawa, Ont. Canmet Report, 79–28: 26.
- MYSŁOWSKI W. 2004. *Lepsze, trwalsze i nie droższe od dotychczasowych technologii wyroby firmy MARBET®-WIL*. Autostrady, 5: 36–37.
- ORŁOWSKI J. 1992. *Betony, modyfikowane sieroj*. Dys. dra tech. nauk: 05.23.05, Charkov, HGTUSA, p. 529.
- Patent 2002. PL 197205. *Elektroizolacyjny materiał budowlany*.
- Patent 2003. PL 205151 B1. *Sposób utylizacji niebezpiecznych odpadów, zwłaszcza popiołów ze spalarni*.
- Patent 2004. PL 196856. *Mieszanka spoiwa siarkowego zawierającego polimer siarki*.
- Patent 2008. PL 197206. *Antyradiacyjny materiał budowlany*.