

Construction of an Expert System Based on Fuzzy Logic for Diagnosis of Analog Electronic Circuits

Damian E. Grzechca

Abstract—The paper presents construction of the fuzzy logic system to analog circuits parametric fault diagnosis. The classical dictionary construction is replaced by fuzzy rule system. The first part refers to analog fault diagnosis, its techniques, approaches and goals. It clarifies common strategy and define differences between detecting, locating and identifying a fault in analog electronic circuit. The second part is focused on a creation of fuzzy rule expert system with use of sensitivity functions and known circuit topology. To detect, locate and identify a faulty element in a circuit the sensitivity matrix is used. The advantage of the method is its utilization in all, AC, DC and time domain. The fuzzy system, like the classical fault dictionary, can detect and locate single catastrophic faults and, on the contrary to the classical one, it also detects and locates parametric faults. Moreover, it allows identification of these faults, such that sign of the faulty parameter deviation is designated. The method has deterministic character as well as it can be applied on the verification and production stage.

Keywords—analog circuits faults diagnosis, analog system testing, fuzzy set theory, expert system, sensitivity analysis

I. INTRODUCTION

ANALOG fault diagnosis is one of the most important and difficult problem of the modern and high quality electronics. Many different approaches have been proposed during the last two decades, none of them solve the problem satisfactorily. ICs with analog, digital, and mixed-signal circuits on the same substrate are now common. Designers want to integrate analog and digital devices on the same chip to reduce circuit packaging and assembly costs. Applications include wireless communication, networking, multi-media information processing (also a personal computer), process control, and real-time control systems. Mixed-signal hardware systems have digital cores, frequently for digital signal processing, surrounded by analog filters, A/D converters, and D/A converters. Figure 1 presents typical mixed circuit testing problem on-a-chip. Analog parts (pre- and post-processing filters, A/D & D/A converters) are responsible for acquiring and generating appropriate analog signals [1, 4].

The analog testing is still a challenge and can be divided into two general categories [2, 3]:

1. Fault Driven Test (FDT), which which measures the circuit responses (e.g. node voltages) for given test stimulus or stimuli, afterwards, component fault can be detected, and eventually further classified, located and identified based on a

fault injection at the before test stage for Circuit Under Test (CUT).

2. Specification Driven Test (SDT) or functional test, which measures the device under test (DUT) functional behaviour (characteristic values of the circuit). The input stimuli is designed to get all possible datasheet information. The main challenge is minimization of input stimuli and optimal test point selection.

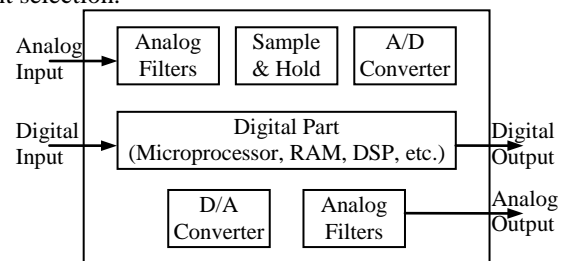

Fig. 1: Structure of a system on-a-chip

Usually, the SDT methods are more expensive due to their measurement time effort (e.g. measurement of frequency response for wide bandwidth). The FDT methods use test measurements, which are less time consuming (e.g. RMS voltage at selected frequency, time response, supply current), what is a very important feature, especially at the production stage. Therefore, integrated circuits (IC) must be characterized before production runs. This involves determining any systematic sources of yield loss, including components which performances may fluctuate significantly due to the variations in manufacturing [3]. Detection of faults are of the main goal for IC and location/identification are of second importance. However, incorrect design of IC may lead to fault in a particular subcircuit (functional block). In such a case, there is a need to locate a block which cases IC failure. It is done based on the IC input/output pins.

For fault driven testing two different techniques are possible: Simulation Before Test (SBT) and Simulation After Test (SAT). The former allows for creating a time efficient system for testing, which can be used during the production stage. SBT methods emphasise on building a fault dictionary in which the nominal CUT behaviours are stored (it can be applied in DC, AC and time domain). During test stage, the measurements are compared with the nominal patterns and the faults are diagnosed. For SAT approach the components (elements) of CUT are computed from the test data (obtained after simulation). It means the first task of parameters (elements) identification technique is to formulate sufficient number of independent equations from the measurements to

determine all components value. The SAT approaches have the disadvantage of high on-line computational complexity, inability to deal with catastrophic faults, error proneness to component tolerances [7].

To simplify the analog testing process, some modifications of a circuit can be introduced during the design stage (e.g. IEEE 1148.4 analog boundary path standard [2]) [12]. This process is called the Design for Testability (DfT) [2-5]. Another complex problem is the test point selection to get the best diagnosability of the system. Very often only heuristic methods give reasonable results because exhaustive search algorithms need great number of calculations [6-10,18]. This area of research will not be discussed in this article.

In the past decade, the analog printed board could be examined with a single measurement device without any sophisticated algorithm because all test nodes were accessible [14, 15]. The growing complexity and miniaturization of mixed integrated circuits need complex classification algorithms that will be applied on a production line. So, the problem is how to achieve the best diagnosis of the CUT if the set of test point is limited and fixed. The standard analog fault classification algorithms, called dictionary, is dependent on the distance measure standard. The test procedure is divided into two parts, where at the before test stage, selected faults are simulated and pattern for a single circuit state is stored. At the after test stage, the means square error measure, the similarity between current (on-line) measure and saved patterns are compared. The nearest distance informs about the circuit state. If a measured parameter and two patterns are in the same distance or the difference is small enough to neglect it, the parameter cannot distinguish the following faults. To avoid uncertainty, the ambiguity region can be introduced, e.g. if the voltage in a node for two simulated faults is less than 0.7V, the faults are not separable [8-9]. Ambiguity set (AS) can also be calculated by Monte Carlo analysis, as presented in [10]. Most of the aforementioned methods are focused on single faults detection, location and identification with tolerances taking into account but there are approaches for multiply concepts [19].

Nowadays, artificial intelligence techniques are in the major area of interest of the scientists [11, 13]. The fuzzy set theory provided by Zadeh [20] is one of that area and is commonly used in many aspects of engineering problems [13, 16, 17]. A fuzzy expert system imitates a human (an expert) decision based on uncertainty premises, like low, high voltages/currents; corner frequency value, slope of characteristic; rise time, delay time, etc. Instead of applying AS the fuzzy diagnostic system can be introduced for comparing e.g. small distance between two patterns. The core of the system is the adaptation of human expert knowledge/perception for finding a single parametric (also called soft) fault in an analog CUT [21-25]. Contrary to the classical logic, the fuzzy logic gives partial belongings to a given fuzzy set V that is described by a membership function μ_V . The fuzzy inference system produces a conclusion which indicates a CUT state. The fuzzy membership functions are described with use of the first order sensitivity matrix \mathbf{S} of a CUT.

In section II, concepts of fault diagnosis in terms of fuzzy logic will be discussed. Fuzzy Diagnosis System (FDS) and automatic rules creation is explained in the section III. An example of hypothetical CUT is examined in the section IV.

II. FAULT DIAGNOSIS AND FUZZY LOGIC

Fault diagnosis answers a question: What element causes the CUT failure? What is the faulty element's actual value or what is its deviation? The diagnosis process follows testing stage on a production line. The most important go/no-go procedure (test) should distinguish faulty circuits (state $f_{L..N}$) from healthy ones (state f_0). Due to the short test time, the go/no-go test and diagnosis is usually performed separately. The design tolerance of elements (resistors, capacitors, transistors) makes the concept of the fuzzy system very adequate. Let's define CUT parameters that vary during production process:

$$\mathbf{P} = \{P_0, P_1, \dots, P_J\} \quad (1)$$

where P_j is a j -th parameter of the circuit, e.g. resistor, capacitor, transistor or operation amplifier gain, etc. This set includes parameters causing both soft and hard faults in the considered system. Let's introduce the set of N faults:

$$\mathbf{F} = \{f_0, f_1, \dots, f_N\} \quad (2)$$

where f_0 is the fault free state.

An AEC has limited test nodes accessibility, and very often only the output node is available outside the chip ($K=I$). On the other hand, any printed board (the final product) can be tested with the use of the bed of nails system (e.g. graphic or sound PC cards). This is a more common procedure in the service stage. In such a case, the system acquires data from large number of test nodes. Therefore, the set of accessible nodes consists of:

$$\mathbf{T} = \{T_1, T_2, \dots, T_K\} \quad (3)$$

In the IC, there are much less nodes then on a printed board, but the presented diagnosis system is to be applied either on a production stage or after manufacturing process (e.g. graphic card tester).

As mentioned in Section I, the test point selection is another problem that will not be discussed here. Circuit parameters (features) measured in a node are defined:

$$\mathbf{M} = \{M_0, M_1, \dots, M_M\} \quad (4)$$

It means that in a single node, more than one parameter can be acquired, e.g. time response gives delay time, overshoot, peak amplitude, and offset, whereas amplitude response informs about e.g. gain for corner frequency or quality factor of a filter.

For a given measurement M_j , the first order absolute sensitivity with respect to input parameter P_k can be obtained from the formula:

$$S_{M_j P_k} = \frac{\partial M_j(P_k^{nom})}{\partial P_k} \quad (5)$$

Assumption 1: a feature in the tolerance margin of an element has the first order approximation – the sensitivity function is linear (see Fig. 2).

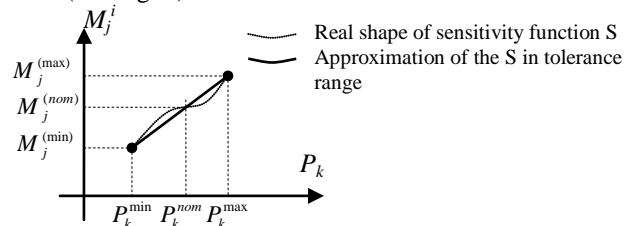

Fig. 2: A sensitivity function within tolerance range

Assumption 2: a sensitivity function outside the tolerance margin is monotonic and can be non-linear.

Another big issue is determination of the ambiguity set (AS) region. It is often introduced in standard (classical) methods to avoid uncertain measurements that are close to each other. Historically, the value of 0.7V is assumed for classic dictionary. Instead of the ambiguity region the fuzzy system has been applied with trapezoidal functions and characteristic values are calculated on the basis of sensitivity functions. Proposed system produces y_{out} the conclusion consisting of both, CUT state and diagnosis level ($f_0...f_N$). In other words, a set of singletons are representing all assumed faults for CUT. A number of singletons is equal to N .

III. FUZZY DIAGNOSIS SYSTEM BASED ON SENSITIVITIES

A. Creation of fuzzy variables

In the following section the 'step by step' procedure for the fuzzy fault dictionary is described. Prior, the fuzzy notation of a linguistic variable $LVar$ for j -th measurement must be defined:

$$LVar_j = \{UD_j, LV_j^{l,n,h}, D_j, \mu_j^{l,n,h}\}$$

where:

UD is Universe of Discourse e.g. voltage in node 1, supply current, IC temperature, overshoot value, delay time, etc.;

LV is Linguistic Value over the UD, e.g. low/short, normal/correct, high/long;

D is physical domain of the UD, e.g. the range of: voltage (-10V...10V), current (0mA...150mA), temperature (-30⁰...+50⁰), time (0...50ms);

μ is a semantic function (membership function) which transforms measured value into fuzzy membership factor (similarity between LV and measurement acquired from CUT). Now, we focus on the translation from physical domain into fuzzy membership factor. As mentioned before, any UD is described by LV because the voltage in a node has one of three states: low, normal, or high. The membership (semantic) functions MF for three states are presented in the fig. 3. There are different types of membership function but trapezoidal once have been chosen due to assumptions and practical behaviour of a CUT. The fuzzy diagnosis system belongs to FDT which means if all elements are within their tolerance range then they are healthy. For non-faulty response the measurements

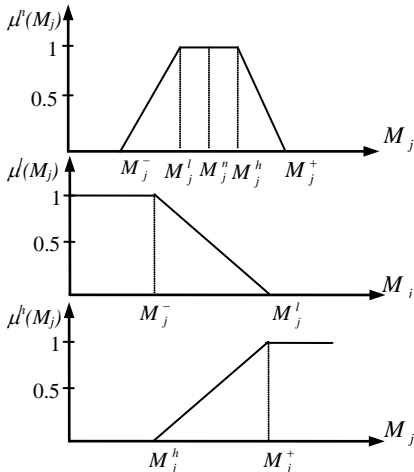

Fig. 3: Membership functions for three LV: normal, low, high

In order to find all characteristic points of LV we must introduce the following assumption:

Assumption 3: the total deviation of the measured feature is the sum of all partial deviations caused by each element introduced separately (the superposition principle). This assumption holds true if and only if the considered element's value is in its tolerance range (see Assumption 1 and Fig. 2). More, the tolerances must be small enough to fulfil above requirements. Obviously, such assumption holds true for electronic circuits containing elements with relatively small tolerances (i.e. less than 5%). However, for linear circuit (especially for resistive one) or circuits tested in DC domain the assumption 3 is fulfilled for much bigger tolerances (i.e. 20%).

Under the above statements, the coefficients for all membership function are calculated from the formulas (8-11). The minimum absolute value of the acceptable partial deviation for a feature M_j :

$$\Delta M_j^{\min} = \text{abs}\left(\min\left\{S_{M_j P_k} \cdot \Delta P_k\right\}\right) \quad j=1, \dots, I \quad (6)$$

The total maximum deviation caused by all considered fault free parameters is equal to:

$$\Delta M_j^{\text{total}} = \sum_{k=1}^J \left| S_{M_j P_k} \right| \Delta P_k \quad (7)$$

The CUT is considered faulty (one out of all states) if the measured feature is greater or lower than:

$$M_j^+ = M_j^n + \Delta M_j^{\text{total}} \quad (8)$$

$$M_j^- = M_j^n - \Delta M_j^{\text{total}} \quad (9)$$

Thus, the maximum value of "low" measurement, due to a single fault is given as:

$$M_j^l = M_j^n + \Delta M_j^{\text{total}} - \Delta M_j^{\min} = M_j^+ - 2\Delta M_j^{\min} \quad (10)$$

The boundary (minimum) value of "high" measurement can be calculated in the same way:

$$M_j^h = M_j^n - \Delta M_j^{\text{total}} + \Delta M_j^{\min} = M_j^- + 2\Delta M_j^{\min} \quad (11)$$

Therefore, all measurements have three defined above membership functions. The feature is translated into fuzzy membership factor (zero one range) from its original domain.

The output of the system should indicate a CUT state. The set of assumed faults have been defined (see eq. 2) and it leads to $N+1$ singletons. If a fault set represents faults location with partial identification (deviation from its nominal value) then each rule produces conclusion containing fault number and membership factor. The final conclusion is done based on defuzzification: first of maximum (FOM method).

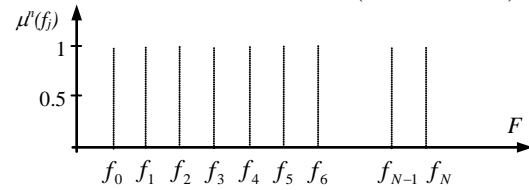

Fig. 4: Singletons representing faults – system output

B. Creation of inference rules

The diagnostic system for analog electronic circuits must have deterministic fundamentals, so for the same inputs the output must remain on the same level. The fuzzy diagnostic system takes its decision on rules. In the following section the creation of rules is discussed in details.

Generally, the sensitivity matrix calculated previously is composed of the positive and negative values. The plus sign attached to the coefficient means that increase of a parameter causes higher value of the corresponding measurement. For negative (minus) sign, the relation is opposite, the increase of a parameter leads to lower value of the feature. Let's consider the exemplary values in the sensitivity matrix:

	P_1	P_k	P_j
M_I	$S_{I1}<0$	$S_{Ik}<0$	$S_{Ij}>0$
M_j	$S_{j1}>0$	$S_{jk}<0$	$S_{jH}>0$
M_M	$S_{M1}>0$	$S_{Mk}>0$	$S_{MJ}>0$

Now, the parameters deviation value P_k can be obtained based on measurements. The premise section of the rule examines the relation between sensitivities sign and features, whereas the conclusion produces the output decision.

The exemplary rules for k -th column and fault free case are presented below:

Premises			THEN	Conclusions
IF	$S_{Ik}>0$	$S_{Ik}<0$		
	M_I is low	M_I is high	M_M is low	P_k is high
	M_j is high	M_j is low	M_M is high	
IF	M_I is norm	M_j is norm	M_M is norm	CUT is fault free

The system indicates faulty parameter i.e. locates undesirable CUT behaviour and partially identifies a fault by producing linguistic value of low or high, attached to the output conclusion. Sometimes, two or more columns in the sensitivity matrix have the same signs which cause location of the parameter impossible. In such a case, the premise section of these rules remains constant but the system shows a set of possible faults.

C. Diagnostic system operations

The output conclusion is taken with the use of measurements and operations on fuzzy expert system. In this approach the input measurement is a singleton shown in the fig. 4.

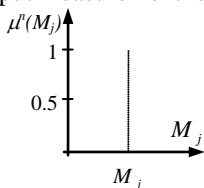

Fig. 5: Measurement representation - singleton function

The fuzzy decision system is composed of three blocks: *fuzzification*, *inference*, and *defuzzification*. The first block, *fuzzification*, converts measured features (voltages, currents, power dissipation, etc.) into the fuzzy factor that describes the similarity level between the feature and the corresponding fuzzy set. Let us focus on Fig. 5 in order to understand the following operations of the proposed system. The input variable (measurement) is a singleton which intersects with the linguistic variable. Three acquired measurements M_0 , M_1 and M_2 are checked with fuzzy sets (occurring in the premise section of the rule). The premise section may contain more than one variable. In such a case, *t-norm* operator is applied like *minimum* or *product*. According to Fig. 5 the *minimum* operator was selected (see projection of three intersections on

Y-axis). The fuzzy relation (relationship between input/premise and output/conclusion) of a rule is calculated by the Mamdani's fuzzy implications the i.e. *minimum* operator between input (fuzzy factor) and output (indicated fault – singleton). Because each rule produces the conclusion – the output value represents the membership factor to one of linguistic variables (in this case it is the fault represented by the singleton). In general, more than one rule may produce a non-zero conclusion. For this reason, before the final decision is made, the aggregation of results coming from each rule is done with the *s-norm* operator e.g. *maximum*. The last step is the defuzzification. This specific diagnostic system for analog electronic circuits should produce clear information about the condition of the CUT. In this approach, the condition means indication of a single state from fault set F . Therefore, defuzzification by the *center of gravity* or *mean* is forbidden because it may lead to the undefined conclusion. It has been decided to use the highest method (first of maximum) because it gives unequivocal information from the fault set. The output group contain fault code and number which represents similarity to the particular fault. If the output level is closer to one the fault is much more certain. As mentioned before, if more than one rule gives similar fault level, the output group shows all possible faults.

The simplest *t-norm* and *s-norm* gives great opportunity for the practical implementation and understanding of the proposed system. However, much more complex operators can be applied e.g. drastic product/sum or Einstein products/sum.

In the next section one practical example is discussed.

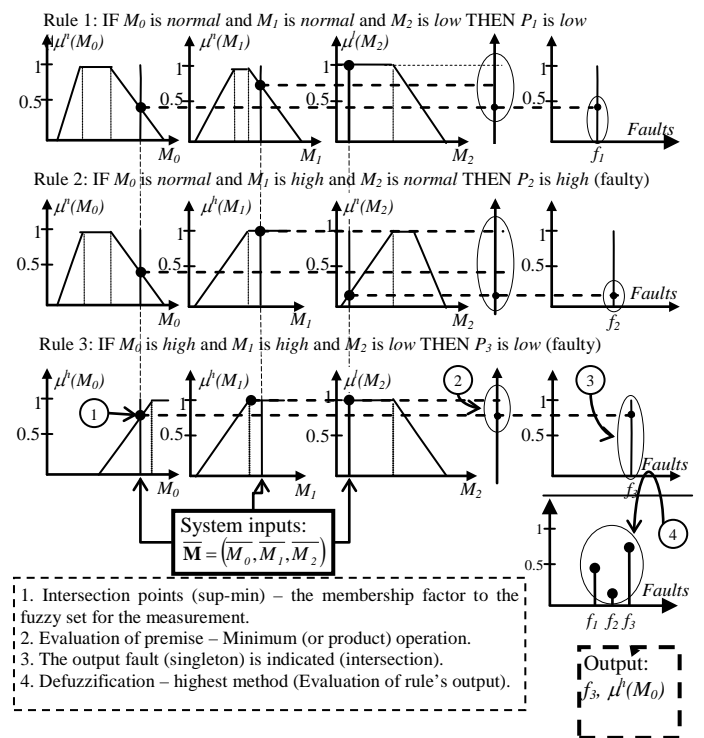

Fig. 6: Exemplary diagnostics system for 3 inputs and 3 rules

IV. FUZZY DIAGNOSTIC SYSTEM IN DC DOMAIN

Presented in the previous section system is to be applied for soft fault diagnosis of the exemplary circuit originally

considered in [8]. The diagnostic procedure is divided into two steps: before test stage and after test stage.

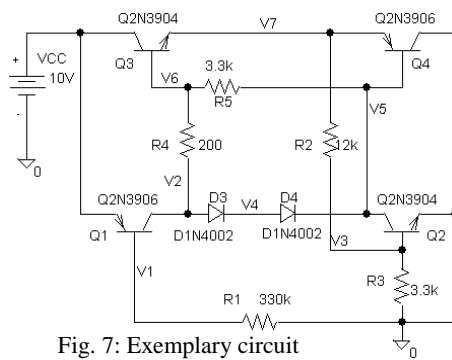

Fig. 7: Exemplary circuit

A. Before Test Stage

At this stage faults and fault free states as well as accessible nodes with measurements are specified. For the circuit shown in the Fig. 6, the parametric faults of resistors are considered. Two types of fault in a resistor have been modelled: $0 < (P_k^l = R_k^l) < (1 - tol) \cdot R_k^n$ for parameter value lower than nominal and $(1 + tol) \cdot R_k^n < (P_k^h = R_k^h) < 2 \cdot R_k^n$ for parameter value higher than nominal. The tolerances for all parameters are set to the value of 5%. Next, circuit features (measurements) are selected for fuzzy system inputs: node voltages $V_{1..7}$ and source current I . Using PSpice circuit simulation program, the sensitivity matrix of the features with respect to the parameters is calculated and printed in Tab. I. Based on equations 6-11 limits for all membership functions are calculated and the premise section of IF-THEN rules are composed with the use of sensitivity matrix.

B. After Test Stage

The robustness of the fuzzy diagnostic system is to be evaluated and compared with classical approach (nearest neighbourhood measure). It has been performed 1000 simulations for a single considered fault and the fault free state. For the resistors defects: two types of faults have been taken into account, the output set consist of 11 states: $F = \{f_0, f_1, \dots, f_{10}\}$, where f_0 is the fault-free state, all even subsidence's indicates *low* value of the parameter, and odd subsidence's represents *high* value of the parameter (outside tolerance margin).

All rules for the fuzzy system are presented in the tab. II, where +1 is "is high", -1 is "is low", and 0 means "is norm". For the investigated circuit the premises of the fault no 7 and the fault no 10 as well as the fault no 8 and no 9 are equal. To avoid misunderstanding, similar rules are connected. Hereafter, for the exemplary system the number of rules decreases to 9 (the last two rules are neglected) but the output part of rule 8 and 9 produces outputs consisting of two faults with the same membership level. For method verification, 1000 simulations for each circuit state have been executed. Moreover, the Classical Dictionary (CD) based on the least square distance has been applied and compared with the proposed method. Such dictionary has been constructed with the use of pattern in the following manner: a pattern for a fault means all healthy elements have its nominal value but the faulty one has *low* or *high* value (parametric fault):

$$R_k^{low_CD} = 0.5R_k^n \quad (12)$$

$$R_k^{high_CD} = 1.5R_k^n \quad (13)$$

Only detection of a single fault for CD is possible because location is on relatively low level (below 25% for all parametric faults). Therefore, the average detection of 64,56% is in the last column of tab. III. Fuzzy system results and comparison are gathered in the tab. III.

TABLE I
SENSITIVITY MATRIX OF THE EXEMPLARY CIRCUIT

	$S_{V_2 R_j}$	$S_{V_3 R_j}$	$S_{V_4 R_j}$	$S_{V_5 R_j}$	$S_{V_6 R_j}$	$S_{V_7 R_j}$	$S_{V_8 R_j}$	$S_{I R_j}$
R_1	7.8E-8	-1.4E-6	-7.8E-8	-1.3E-6	-1.2E-6	-1.4E-6	-1.4E-6	8.6E-9
R_2	2.5E-13	2.7E-4	-2.6E-13	2.7E-4	2.7E-4	2.7E-4	2.7E-4	2.8E-14
R_3	-8.2E-13	-8.9E-4	6.8E-9	-8.9E-4	-8.9E-4	-8.9E-4	-8.8E-4	7.3E-8
R_4	3.4E-13	3.6E-4	-3.6E-13	3.6E-4	3.6E-4	-1.5E-7	-1.1E-11	1.5E-9
R_5	-2.E-14	-2.2E-5	2.1E-14	-2.3E-5	-2.4E-5	9.7E-9	6.7E-13	-1.E-10

TABLE II
RULES OF THE FUZZY DIAGNOSIS SYSTEM

Rule	IF section (measurements)								Conclusion
	V_2	V_3	V_4	V_5	V_6	V_7	V_8	I	Fault (state)
1	0	0	0	0	0	0	0	0	No fault (0)
2	1	-1	-1	-1	-1	-1	-1	1	R_1^{high} (1)
3	-1	1	1	1	1	1	1	-1	R_1^{low} (2)
4	1	1	-1	1	1	1	1	1	R_2^{high} (3)
5	-1	-1	1	-1	-1	-1	-1	-1	R_2^{low} (4)
6	-1	-1	1	-1	-1	-1	-1	1	R_3^{high} (5)
7	1	1	-1	1	1	1	1	-1	R_3^{low} (6)
8	1	1	-1	1	1	-1	-1	-1	R_4^{high} (7)/ R_5^{low} (10)
9	-1	-1	1	-1	-1	1	1	-1	R_4^{low} (8)/ R_5^{high} (9)
10	-1	-1	1	-1	-1	1	1	-1	R_5^{high} (9)
11	1	1	-1	1	1	-1	-1	1	R_5^{low} (10)

TABLE III
SIMULATION RESULTS FOR FUZZY SYSTEM AND CLASSICAL DICTIONARY

CUT state	Detection	Localization	CD	
R_1^{low}	100	95,2	64,56	
R_1^{high}	100	89,3		
R_2^{low}	99,6	51,2		
R_2^{high}	99,1	50		
R_3^{low}	99,5	23,4		
R_3^{high}	99,9	40,3		
R_4^{low} or R_5^{high}	42	3,9		
R_4^{high} or R_5^{low}	49,3	2,3		
Fault free state	67,6	--		49,9
Average result	86,18	44,45		

Results obtained by the fuzzy diagnostic system are much better than nearest neighbourhood method (keeping in mind it is the most common strategy today). Average detection rate for soft fault exceed 86%. The presented system gives much more information: not only localization of a single fault but also deviation from its nominal value. The weakest point of fuzzy decision system is indication of fault free circuit. It has been observed that other *t-norms* and *s-norms* may increase average level for healthy circuit state however it requires further investigation.

V. CONCLUSIONS

The great advantage of the proposed fuzzy diagnostic system is its deterministic character and clear "step by step" construction procedure. There are many excellent methods based on artificial intelligence of no practical application. All industrial methods must be predictable and only such algorithms can be applied in practice. A test engineer can apply this method using the sensitivity matrix for the CUT. It leads to automatic rules construction and fuzzy membership

creation. The presented in the paper belongs to Fault Driven Test but with some modification it can be applied for Specification Driven Test. In such approach a sensitivity of an output specification with respect to the particular block parameters must be calculated at first.

The test constructor may use general idea of the system with other types of membership function, fuzzy implication or t -norm and s -norm operators. The system provides a number of parameters which can be adjust for a particular circuit under investigation.

Proposed system can effectively detect a single parametric fault as well as locate it what is impossible for classic dictionary. All non-faulty elements may fluctuate within their tolerance margin what is a must for today test systems. Another unique feature of fuzzy system is partial identification of parametric faults.

Summarizing, benefits of the proposed system are: fast and easy construction based on sensitivity matrix, effectiveness (compare with distance dictionary), practical implementation, very fast decision.

REFERENCES

- [1] Michael L. Bushnell, Vishwani D. Agrawal, *Essentials of Electronic Testing for Digital, Memory and Mixed-Signal VLSI Circuits*, Kluwer Academic Publishers 2002, ISBN: 0-306-47040-3.
- [2] I. L. Huertas, *Test and design for testability of analog and mixed-signal integrated circuits: theoretical basis and pragmatical approaches in 1993 Proc. ECCTD Conf.*, pp. 75-156.
- [3] L. S. Milor, *A Tutorial Introduction to Research on Analog and Mixed-Signal Circuit Testing*, IEEE Trans. on Circuits and Systems-II, vol.45, pp. 1389-1407, no.10,1998.
- [4] A. Richardson, A. Lechner, and T. Olbricht, *Design for Testability for Mixed Signal & Analogue Designs – From Layout to System*, in 1998 Proc. ICECS, pp.425-432.
- [5] Pen-Min Lin and Y. S. Elcherif, *Computational Approaches to Fault Dictionary, Analog Methods for Computer-Aided Circuit Analysis and Diagnosis*, M.Dekker, 1998.
- [6] V. C. Prasad and N. S. C. Babu, *Selection of test nodes for analog fault diagnosis in dictionary approach*, IEEE Trans. Instrum. Meas., vol.49, pp.1289-1297, no.6, 2000.
- [7] Prithviraj Kabisatpathy, Alok Barua, Satyabroto Sinha, *Fault Diagnosis of Analog Integrated Circuits*, Frontiers in Electronic Testing, Vol. 30, Springer 2005.
- [8] J. A. Starzyk, Dong Liu, Zhi-Hong Liu, Dale E. Nelson, and J. Rutkowski, *Entropy-Based Optimum Test Points Selection for Analog Fault Dictionary Techniques*, IEEE Trans. on Instr. and Measur., vol.53, no.3, June 2004, pp. 754-761.
- [9] T. Golonek, J. Rutkowski, *Genetic-Algorithm-Based Method for Optimal Analog Test Points Selection*, IEEE Trans. on Cir. and Syst.-II., Vol.54, No.2, pp. 117-121, 2007.
- [10] J. Rutkowski and T. Golonek, *Application of Genetic Algorithms to Analog Fault Diagnosis*, in 2001 Proc. ECCTD, pp. 253-256.
- [11] M. Aminian, F. Aminian, *A Modular Fault-Diagnostic System for Analog Electronic Circuit Using Neural Networks With Wavelet Transform as a Preprocessor*, IEEE Trans. on Inst. and Measur., vol. 56, no. 5, Oct. 2007.
- [12] T.R. Balen, J.V. Calvano, M.S. Lubaszewski, M. Renovell, *Functional Test of Field Programmable Analog Arrays*, Proc. of the 24th IEEE VLSI Test Symposium (VTS'06)
- [13] P. Bilski, M. Wojciechowski, *Automated Diagnostics of Analog Systems Using Fuzzy Logic Approach*, IEEE Trans. on Inst. and Measur., Vol. 56, No. 6, Dec. 2007.
- [14] Z. Czaja, R. Zielonko, *On fault diagnosis of analogue electronic circuits based on transformations in multi-dimensional spaces*, Measurement 2004, vol. 35, no. 3, pp.293-301.
- [15] S. R. Das, J. Zakizadeh, S. Biswas, M.H. Assaf, A. R. Nayak, E. M. Petriu, W.-B. Jone, M. Sahinoglu, *Testing Analog and Mixed-Signal Circuits With Built-In Hardware – A New Approach*, IEEE Trans. on Inst. and Measur., Vol. 56, No. 3, Jun. 2007.
- [16] Peng Wang, Shiyuan Yang, *A New Diagnosis Approach for Handling Tolerance in Analog and Mixed-Signal Circuits by Using Fuzzy Math*, IEEE TCSAS-I, Vol. 53, No 10, Oct. 2005.
- [17] Grzechca D. Golonek T., Rutkowski J., *Simulated Annealing with Fuzzy Fitness Function for Test Frequencies Selection*, IEEE Conference on Fuzzy Systems, FUZZ-IEEE 2007, London, UK.
- [18] Grasso F. et al, *A Method for the Automatic Selection of Test Frequencies in Analog Fault Diagnosis*, IEEE Trans. on Instr. and Measur., Vol. 56, No 6, Dec. 2007.
- [19] M. Tadeusiewicz, S. Hałgas, *An algorithm for multiple fault diagnosis in analogue circuits*, Int. Journal of Circuit Theory and Applications, J.Wiley & Sons. Ltd., 34, pp.607-615, 2006.
- [20] Zadeh L.A., *Fuzzy Sets*, Inf. Control, August 1965, pp.338-353.
- [21] Grzechca D., Rutkowski J., *Analog Fault Dictionary - Fuzzy Set Approach*, European Conference on Circuit Theory and Design, ECCTD 2001, Espoo, Finland, pp. 249-252.
- [22] Abdulhafour, M.; El-Gamal, M.A., *A fuzzy logic system for analog fault diagnosis*, International Conference on Circuits and Systems, 1996. ISCAS '96, pp. 97- 100.
- [23] Kumar A, Singh AP., *Fuzzy classifier for fault diagnosis in analog electronic circuits*, ISA Trans., 52(6):816-24, 2013.
- [24] Pous, C.; Colomer Llinas, J.; Melendez, J.; de la Rosa, J.Ll. *Fuzzy identification for fault isolation*. Application to analog circuit diagnosis, Frontiers in Artificial Intelligence and Applications 409-420, 2003.
- [25] Grzechca, D.; Golonek, T.; Rutkowski, J., *Analog fault AC dictionary creation - the fuzzy set approach*, Circuits and Systems, 2006. ISCAS 2006.