

NOTES

Ergonomic Hand Tool and Desk and Chair Development Process

Dongmin Shin
Jung-Yong Kim

Information and Industrial Engineering, Hanyang University, Ansan, South Korea

M. Susan Hallbeck

Industrial and Management Systems Engineering, University of Nebraska, Lincoln, USA

Joel M. Haight

Energy and Geo-Environmental Engineering, Pennsylvania State University, University Park, USA

Myung-Chul Jung

Industrial and Information Systems Engineering, Ajou University, Suwon, South Korea

This paper suggests a practical and simple process consisting of 8 stages: needs assessment, ergonomics guidelines, anthropometry, brainstorming and idea sketch, preliminary model, drafting and rendering, working prototype, and user trials. The feasibility of this process was verified with the development of a modified clamping hand tool and a new student desk and chair. The case studies showed how design difficulties were overcome by integrating ergonomics guidelines in the process.

ergonomics process hand tool desk and chair

1. INTRODUCTION

Companies have realized the importance of ergonomics because ergonomically designed products have a competitive advantage in the marketplace. A product may be simple or complex; however, its development process involves a series of events of identifying the user's needs, defining design concepts, making a prototype, testing usability, and releasing a product to the market. Iterative application of the most relevant knowledge and experience throughout this process

will yield an ergonomically sound product. On the basis of this general process, a rather practical process for ergonomic products was developed and demonstrated with two case studies: a clamping hand tool handle and a student desk and chair.

2. DEVELOPMENT PROCESS

Users recognize the need for a new product. Full understanding of who wants what products is the most important factor [1, 2]. The user's needs

could be specified with various evaluation techniques, e.g., observations, questionnaires, interviews, expert appraisals, safety analyses, and task analyses [3].

Many ergonomics guidelines are available in the literature, but these are often too general for specific applications; therefore, ergonomists need to extract concrete information from the guidelines for a specific product [1]. Anthropometric data are of importance to determine the dimensions of a product.

It is suggested that ergonomics knowledge be considered at the earliest stages of the development process. A development team typically takes the user's needs and ergonomics data and then brainstorms imagined potential designs. Idea sketches and preliminary models involve making these imagined designs real. The preliminary model is an intermediate prototype for successive refinements to reflect information found in the previous stages.

Drafting and rendering are completed with a computer-aided design system. Drafts of the dimensions of a working prototype are created on the basis of a preliminary model and rendering illustrates a three-dimensional computer model

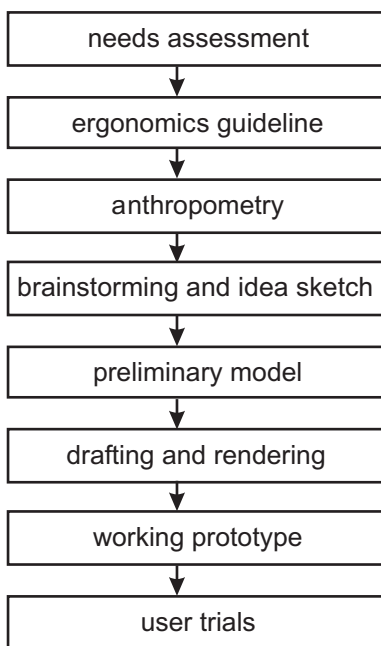

Figure 1. Practical ergonomic product development process.

that is useful in discussions with users before a working prototype is made. Building a working prototype depends on available technologies, e.g., handwork or rapid prototyping [4, 5]. Though the same methods employed in the needs assessment stage can be administered for usability testing, the most valuable and reliable method to evaluate a working prototype is a combination of subjective and objective user trials [3, 6].

Figure 1 shows a schematic diagram of the process for ergonomic product development. Manufacturing may be added at the end of the process as another stage. If necessary, any stage in the process can be reiterated anytime for a more user-friendly and safer product, depending on time constraints and potential costs.

3. CASE STUDIES

3.1. Clamping Hand Tool

The case study on the redesign of a handle of a commercial clamping hand tool arose from discussion with the company (Figure 2). User input and ergonomics analysis showed that the original handle concentrated pressure on the tender tissue of the palm and pinched the index finger. Moreover, the span of the grip was too large to allow the fingers to reach due to trumpet-shaped contours.

For this type of handle design, Konz and Johnson suggested a circular cross-sectional



Figure 2. Original handle of a clamping hand tool.

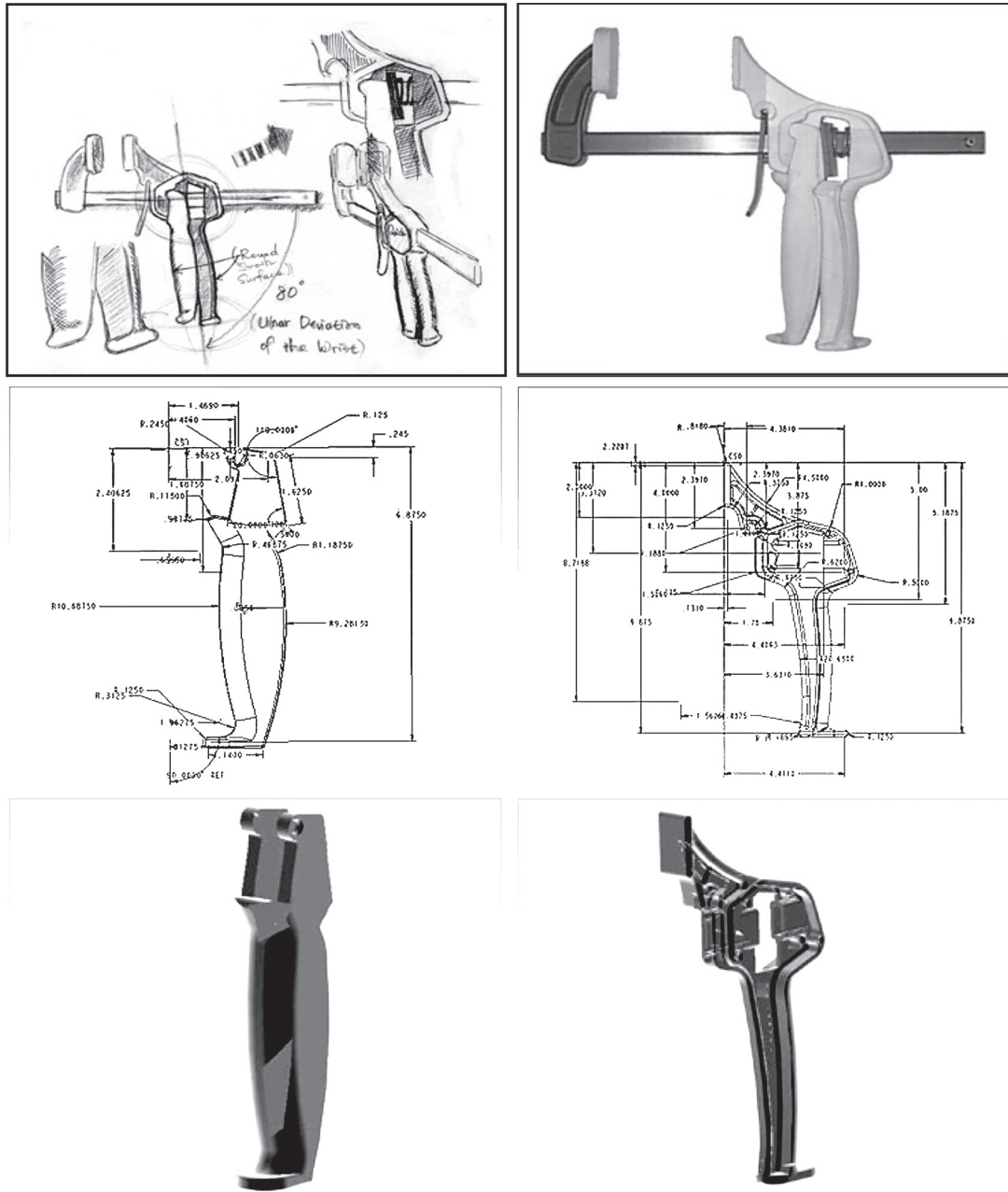

Figure 3. Idea sketch (top left), preliminary model (top right), drafts (middle), and renderings (bottom) of the new handle.

handle, no grooves or indentations, a guard, and a flange [7]. They also recommended initial handle openings ranging from 5 to 10, and 12.5 cm as handle length.

On the basis of these guidelines, the design concepts of a new handle were sketched during a brainstorming session. The new handle was made as a preliminary model using balsa wood (Figure 3). The drafts were drawn for the

dimensions of a working prototype based on the preliminary model. Each part of the new handle was rendered with Pro/Engineer® release 20 (Parametric Technology Corporation, USA) and a working prototype was built using rapid prototyping techniques [8].

A direct comparison was performed using the original tool and the working prototype. Twenty college students performed 24 clamping tasks

TABLE 1. Means and Standard Deviations of User Trials of the New and Original Handles

Measures		New	Original
Forces (N)	object-clamping	236 ± 115	190 ± 90
	handle-squeezing	333 ± 142	443 ± 115
Subjective rates	functionality	5.55 ± 1.23	4.30 ± 1.69
	postural comfort	5.30 ± 1.13	4.15 ± 1.39
	force exertion	4.60 ± 1.14	5.30 ± 0.98

Notes. A 7-point scale (1—least, 7—most) was used for subjective rates.

according to the experimental design [9]. Two load cells were mounted in the jaw and the handle to measure object-clamping and handle-squeezing forces. A questionnaire with a 7-point scale (1—least, 7—most) contained questions about functionality, postural comfort, and perceived hand force exertion [10].

The result of *t* tests showed that the measures were all significant at a level of .05 (Table 1). The new handle required about 25% less handle-squeezing force while producing about 21% more object-clamping forces than the original clamp. The participants felt more comfort and perceived lower hand force while squeezing the new handle compared to the original one. These advantages also increased the functional efficiency of the ergonomically redesigned handle.

3.2. Student Desk and Chair

Thirteen sizes of a scaled desk and chair are supplied to K–12 public schools in South Korea. The correct size is not often provided to each student due to an inappropriate inventory. This may cause great physical stress, especially for young students confined to the chairs and desks for an entire school day.

A questionnaire was developed to identify the student user's needs for a new desk and chair design. It had three groups of questions about functionality, aesthetics, and discomfort using a 5-point scale (1—very negative, 5—very positive), sentence completion, and short answers. Three hundred and thirty-three students participated in the survey. They suggested a backpack hanger, a smooth desktop, and a spacious drawer for a new desk, and proper height and width for a new chair.

Ergonomics guidelines for a desk and chair design were extracted from Grandjean [11]. Nine necessary anthropometric data were also obtained from the anthropometric database.

Figure 4 shows the idea sketch and preliminary model of a desk and chair design. After close communication with the company, the final model was constructed in two sizes for marketability and manufacturability reasons; one for elementary school students and the other for middle and high school students.

After the preliminary model was carefully dissected and measured, final drafts and a three-dimensional computer model were created with 3D Studio release 2 (Autodesk, Inc., USA), and two sizes of the working prototypes were fabricated [12].

Ten students used the working prototypes for one day and then filled out another questionnaire on satisfaction, aesthetics, and discomfort of the trunk, hip, and leg using a 5-point scale (1—least, 5—most) [13].

The results of *t* tests showed that all measures were significant at a level of .05 (Table 2). The new desk and chair increased the satisfaction

TABLE 2. Means and Standard Deviations of User Trials of the New and Current Desks and Chairs

Measures		New	Current
Satisfaction	desk	4.3 ± 0.82	3.1 ± 1.37
	chair	4.4 ± 0.70	3.2 ± 1.40
Aesthetics	desk	4.3 ± 0.48	3.0 ± 1.33
	chair	4.2 ± 0.92	3.0 ± 1.33
Discomfort	trunk	2.6 ± 1.43	4.4 ± 0.84
	hip	2.9 ± 1.52	4.3 ± 1.06
	leg	2.6 ± 0.97	4.1 ± 0.88

Notes. A 5-point scale (1—very negative, 5—very positive) was used.

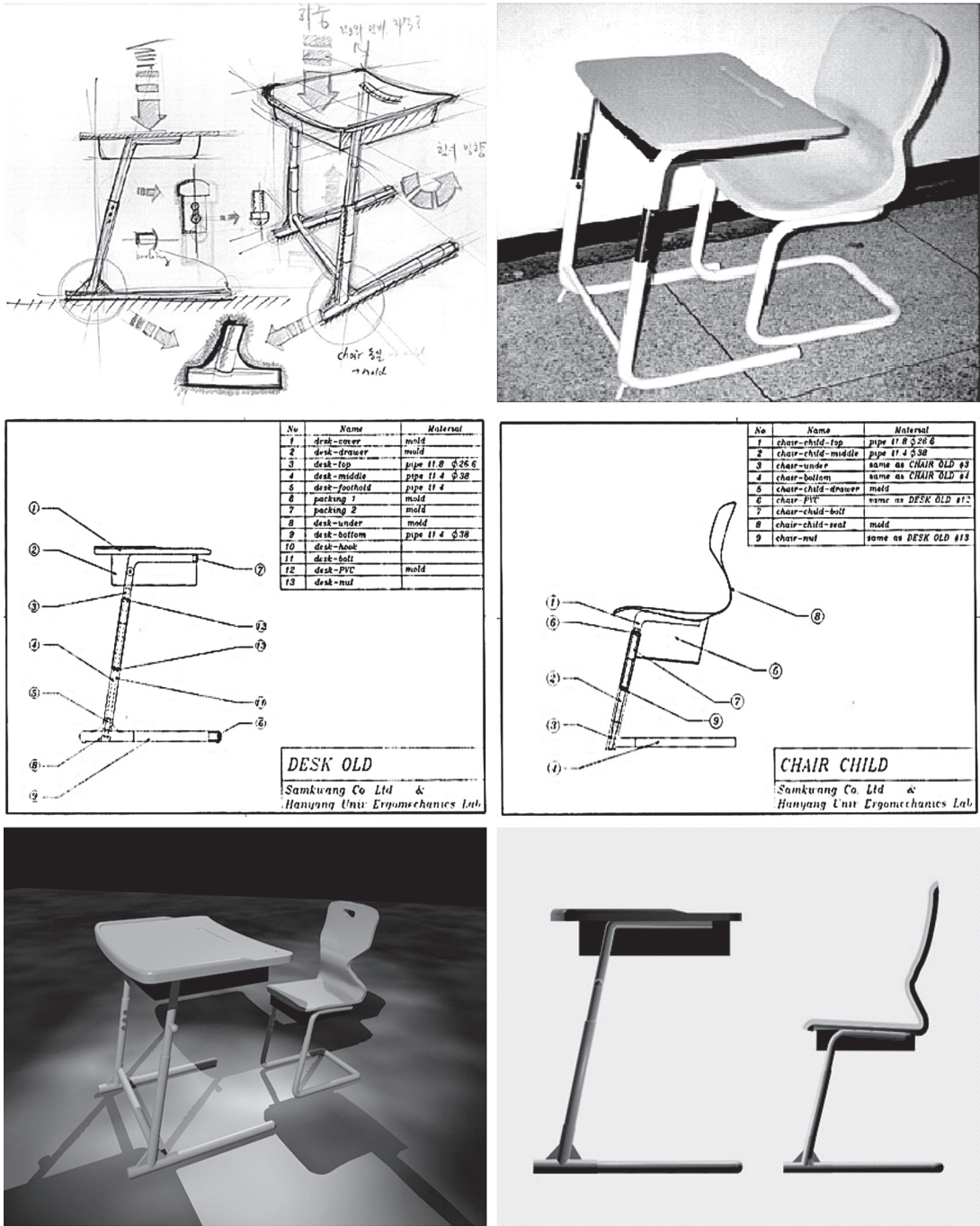

Figure 4. Idea sketch (top left), preliminary model (top right), drafts (middle), and renderings (bottom) for the student desk and chair.

of the participants by 39% for desks and 38% for chairs, and the aesthetic preference by 43% for desks and 40% for chairs. In addition, the new design decreased discomfort in the trunk, hip, and legs by 41, 33, and 37%, respectively, compared the current model.

4. DISCUSSION

The feasibility of the process recommended for ergonomic product development was illustrated through two case studies. The first case study demonstrates the modification of an existing product. Observation of the original clamp, in conjunction with ergonomics evaluations,

was used to identify the user's needs. Specific ergonomics guidelines and anthropometric data, especially for the two-handed tool, were obtained from the ergonomics literature. The fully functional working prototype was evaluated with objective (direct force measurement) and subjective (questionnaire) methods. The use of ergonomics guidelines yielded a functional tool that was objectively improved and was preferred over the current tool.

The second case study demonstrates that even K–12 students know what they need in a “work” environment. What students really wanted for their desk and chair was revealed with observations, expert appraisals, and questionnaire responses. The company provided critical information in the stages of the idea sketch and working prototype that a development team alone might have overlooked for success of ergonomic products in the market such as ease of manufacturing or maintainability. The two questionnaires developed for design needs assessment and the subjective user trials were based on Zhang, Helander, and Drury [13]. This case study shows that the application of good ergonomics principles can increase satisfaction even in K–12 students.

Though rather simple, this suggested ergonomic product development process was deemed successful because the new student desk and chair were launched into the marketplace. It is not expected that the development process is applicable to all products but it may be adapted for most engineering designed products, even with the short development time often placed on many product development cycles.

REFERENCES

1. Chapanis A. Ergonomics in product development: a personal view. *Ergonomics*. 1995;38:1625–38.
2. Khalid HM, Helander MG. A framework for affective consumer needs in product design. *TIES*. 2004;5:27–42.
3. Page M. Consumer products—more by accident than design? In: Stanton N, editor. *Human Factors in Consumer Products*. London, UK: Taylor & Francis; 1998. p. 127–46.
4. Evans M. Applying ergonomics methods during the industrial design of consumer products. In: Stanton N, editor. *Human Factors in Consumer Products*. London, UK: Taylor & Francis; 1998. p. 193–202.
5. Lopez SM, Wright PK. The role of rapid prototyping in the product development process: a case study on the ergonomic factors of handheld video games. *RPJ*. 2002;8:116–25.
6. Butters LM, Dixon RT. Ergonomics in consumer product evaluation: an evolving process. *Appl Ergon*. 1998;29:55–8.
7. Konz S, Johnson S. *Work design: industrial ergonomics*. Scottsdale, AZ, USA: Holcomb Hathaway; 2000.
8. Mettu SK. Integration of ergonomic evaluation with time compression technologies (rapid prototyping, solid modeling and predictive engineering) for redesign of hand tool components [master's thesis]. Lincoln, NE, USA: University of Nebraska; 2000.
9. Jung MC, Hallbeck MS. Ergonomic redesign and evaluation of a clamping tool handle. *Appl Ergon*. 2005;36:619–24.
10. Kuijt-Evers LFM, Groenesteijn L, de Looze MP, Vink P. Identifying factors of comfort in using hand tools. *Appl Ergon*. 2004;35:453–8.
11. Grandjean E. *Fitting the task to the man*. London, UK: Taylor & Francis; 1988.
12. Jung MC, Hyun SD, Shin KY, Hong SS, Kim JS, Kim JY. Ergonomic student desk and chair development. In: *Proceedings of the Fall Conference of the Ergonomics Society of Korea*. Seoul, South Korea: Ergonomic Society of Korea 1996. p. 85–90.
13. Zhang L, Helander MG, Drury CG. Identifying factors of comfort and discomfort in sitting. *Hum Factors*. 1996; 38:377–89.