

## PHOTOVOLTAIC SYSTEM DESIGN FOR STRATEGIC INFRASTRUCTURE AND MOBILE COMMAND CENTRE

**Jan Fabián\***

Brno University of Technology  
10 Technická, 616 00 Brno, Czech Republic, [xfabia09@vutbr.cz](mailto:xfabia09@vutbr.cz)  
 <https://orcid.org/0000-0002-4761-0821>

**Tomáš Binar**

University of Defence  
65 Kounicova, 662 10 Brno, Czech Republic, [tomas.binar@unob.cz](mailto:tomas.binar@unob.cz)  
 <https://orcid.org/0000-0003-4426-2857>

**Pavel Šafl**

Brno University of Technology  
10 Technická, 616 00 Brno, Czech Republic, [xsaflp00@vut.cz](mailto:xsaflp00@vut.cz)  
 <https://orcid.org/0000-0002-4430-3551>

*Article history: Received 25 September 2022, Received in revised form 21 October 2022, Accepted 21 October 2022, Available online 21 October 2022*

### Highlight

This paper focuses on the design of photovoltaics systems for energy self-sufficiency of strategic infrastructure as well as mobile applications (e.g., command centres, first responders, refugee camps).

### Abstract

With both the ecological and economical aspect of fossil fuels as a source of energy, the demand for renewable sources is rising. This paper aims to analyse two scenarios, which would benefit from the use of a photovoltaic system. In the first scenario, a strategically important warehouse is analysed, and a photovoltaic system is designed and simulated. In the second scenario, two designs of photovoltaic systems that could be used in mobile applications by first responders, military command centres, or during natural disasters are proposed. The results of the simulations are discussed and may serve as a basis for real-life system design and application.

### Keywords

renewable energy; photovoltaics design; mobile PV applications; energy self-sufficiency.

### Introduction

With the continuous development of renewable energy sources and the pursuit of clean energy, sources like photovoltaics, small wind turbines etc., have found great use in small-scale and stand-alone applications [1]. Based on this, the limitation of fossil fuels as a source of energy in remote areas, and the growing price of fossil fuels (tied to the economic crisis, the war in Ukraine etc.), designs for the replacement of fossil fuel sources by renewable energy sources are not only needed but also desired in many fields and applications [2].

Ranging from civil sector to military and first responders' applications, photovoltaic systems can present a reliable source of energy not only for strategically or otherwise important facilities (warehouses, hospitals, etc.) but also for mobile applications, such as command centres, refugee camps or the units of integrated rescue system for their operations in remote areas or disaster relief operations [3]. Mobile photovoltaic systems could present a reliable source of renewable energy in such operations and may also bring down the cost of such operations of the integrated rescue system. This paper aims to analyse two proposed scenarios that would benefit from the use of photovoltaic systems and to design and simulate those systems. For the use of photovoltaics for important infrastructure, the systems are mainly designed to increase energy self-sufficiency and can consist of multiple sources (i.e., photovoltaics and wind turbines). In mobile applications, the main goal is for the system to be easily transportable, modular, scalable, and not require specialized personnel to operate it. Currently, various versions of mobile photovoltaic and hybrid systems for use in stand-alone, remote applications as well as for military applications exist. Such examples can be the Alfons Mobile Energy Container

[4], Energy Power Rack [5], and Multicon container [6] or various prototypes of hybrid systems for mobile applications [7] and other systems aimed at micro-grids for the use in applications such as refugee camps [8,9].

### Methods

In order to appropriately evaluate the possible benefits and the negatives of the use of photovoltaics as a sustainable source of energy for important applications a two-step methodological approach – Analysis, Design & Simulation - was created. In the first step, we focused mainly on analysing the chosen scenarios. To design a system for important infrastructure, a central army warehouse was chosen based on its national and international strategic importance (from the viewpoint of NATO forces). On visits to this warehouse, we investigated the internal processes, the material stored there and the infrastructure of the army base. A theoretical proposal of automated design for this warehouse was also considered. For the second scenario (mobile command centre), we discussed the importance of mobile command centres for fast response in the case of natural disasters such as tornadoes or floods. With the integrated rescue system needing a stable base of operation as well as a command centre, we focused especially on features such as mobility, modularity of the equipment and being energy self-sufficient [10]. A hypothetical situation based on historical floods in the town of Bohumin was used for this scenario. The second step consisted of creating a 3D model and a design of a practically applicable PV system for each scenario (Figure 1, Figure 2).

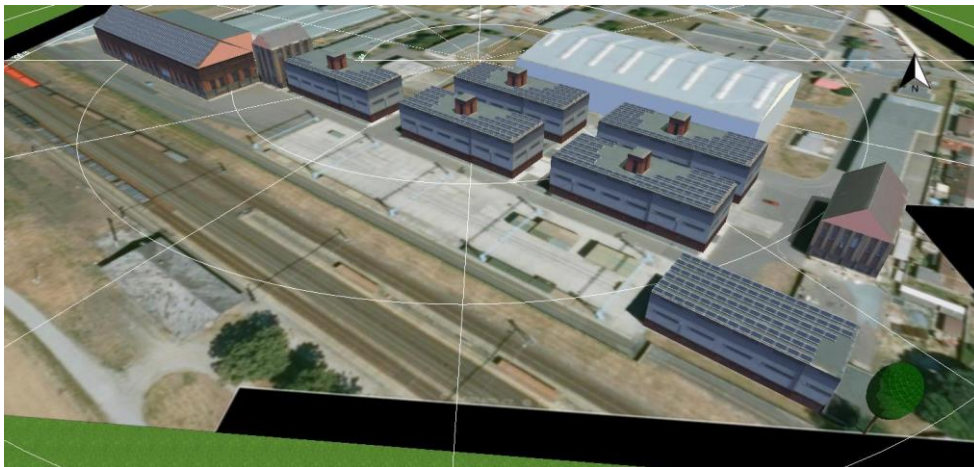

Figure 1. Warehouse PV system visualisation. *Source: Own.*



Figure 2. Mobile command centre PV system visualisation. *Source: Own.*

For the simulation of proposed solutions and their further optimization, PV\*Sol software was used. Apart from the calculations, this system was also used for the creation of 3D models of the scenarios, which enabled us to account for external influences on the PV systems (e.g., shading). Based on the computed data, both systems were evaluated and optimized for better efficiency. Simulations for both scenarios were also run with the implementation of a backup generator into the system.

#### Automated warehouse scenario

The proposed automated design for a warehouse of 4 500 m<sup>2</sup> used for this scenario considers six automated ground vehicles (AGV) and a human staff of five employees. This means that there is no reduction in energy consumption due to safety standards needed for the human staff, however, the level of automatization promises increased efficiency in electric energy usage. Based on the analysis of the internal processes, case study on energy consumption in automated warehouses [11], other studies [12,13], and educated guess, the yearly energy consumption of the facility to be used in the design of the PV system was set as 415 000 kWh. Both the automatization and the importance of the facility to the Czech Armed Forces encourage the design of a solution for situations such as blackouts, which would also aim to increase the energy self-sufficiency of the facility. To guarantee energy self-sufficiency of important infrastructure even during blackouts, a practical solution used by GoodWe company was considered for the design (Figure 3) [14]. This solution uses regulated generators that are connected to the PV system, and are started in the case of grid failure, thus simulating grid parameters (voltage, FQ) needed for the operation of the inverters. They are also used to supply electricity into the system when the PV system is not operational (night, weather conditions).

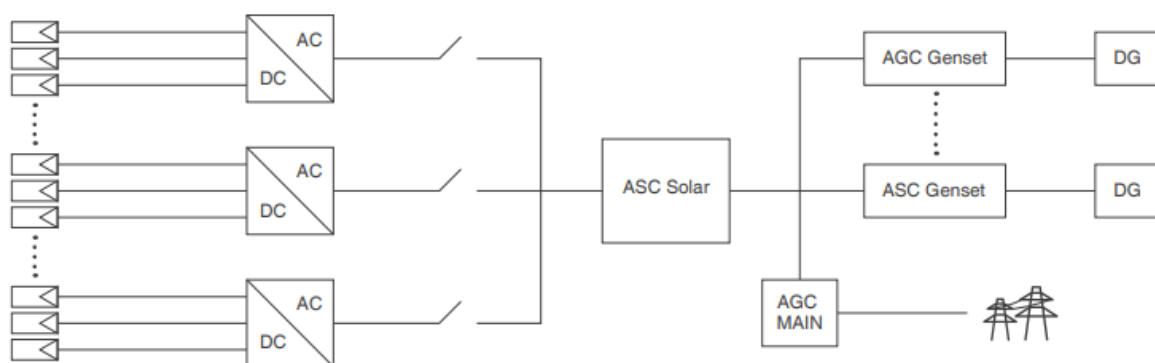
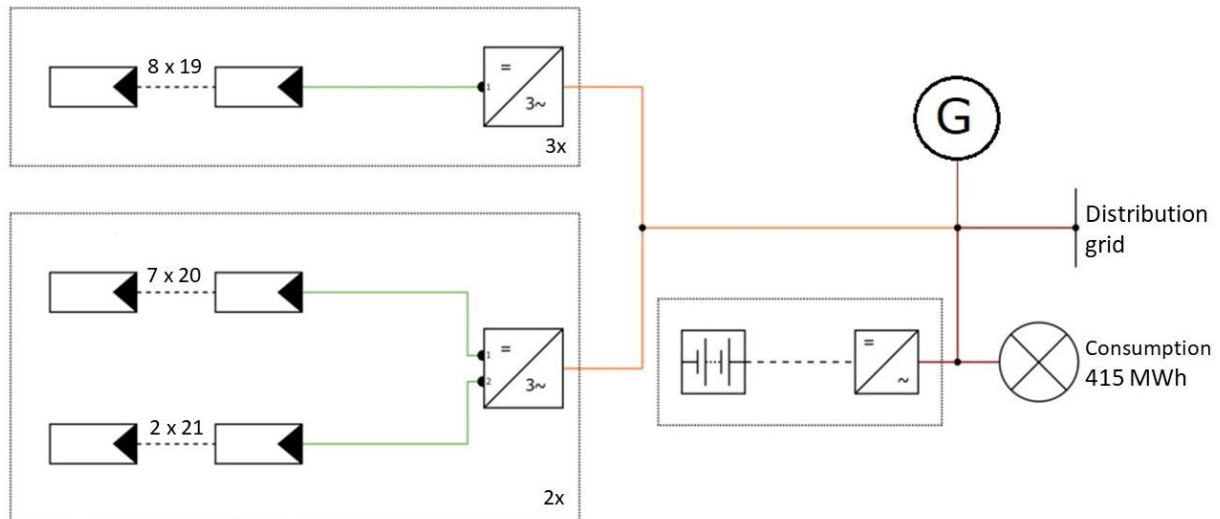

Figure 3. Backup generator scheme. Source: [14].

As the warehouse building by itself is not suitable for PV system installation, the roofs of surrounding buildings were chosen for the installation of the solar panels. Although the one inclined and six flat roofs offer ideal mounting surfaces, the SW (ca 220°) orientation reduces energy yield in the early mornings and creates slightly sub-optimal conditions for the system with energy being generated up to the late afternoon when the consumption is lower. This shows us the importance of batteries in the PV system as the available energy storage greatly increases the overall efficiency of the system.

The proposed PV system consists of 820 solar panels in total, with an installed power of 492 kWp. CanadianSolar HiKu7 CS7L-600 [15] panels were chosen for this system based on their 600 W peak output power and efficiency of 21.2%. To convert the DC output to an AC output, five central inverters are used. These are GoodWe MT GW80KBF-MT [16] inverters with a nominal output of 80 kW. These inverters are able to work with very low starting voltages (200 V) and can work up to 150% of the nominal input voltage. From the wide range of generators used by the Czech Armed Forces, a three-phase, 60 kW 230/400V, diesel generator ČSAD-60-3-400 was used. Based on current trends in storage technologies, Lithium-iron-phosphate batteries made by Sonnen GmbH company were chosen. To ensure enough capacity, a total of 540.6 kWh of battery capacity was used in the design. For the batteries to be able to be charged also by the grid or backup generator, they are connected in AC coupling. Although this type of connection introduces some losses of energy into the system, it is outweighed by the ability to be charged by sources other than solar power. A schematic diagram of the proposed system can be seen in Figure 4.

Figure 4. Schematic diagram of the proposed system. *Source: Own.*

#### Mobile command centre scenario

The main goal of this scenario was to design and simulate a mobile photovoltaic system that would be able to provide electric energy for a command centre in a crisis, such as floods or other natural disasters. It was important for the proposed design to remain as mobile as possible and to supply enough energy. This was achieved with two designs, a fully off-grid photovoltaic system and an off-grid PV system with a backup generator. An interval of 6 months (April - September) was used for these simulations. This was due to the lesser probability of the need for mobile command centres during the rest of the year. Due to the lower availability of solar power during winter, completely self-sufficient system would not be optional. With regards to mobility, the design of a system with a backup generator would also be prioritised before other forms of hybrid systems. In the case of natural disasters or other situations, a command centre presents a strategically important part in the coordination of rescue teams and other forces. The design for this scenario was proposed with not only military applications in mind, but also the possibilities it presents for the integrated rescue system, who could utilize this system for assistance during natural disasters or in refugee camps [3,8,9]. Command centres should represent real control, communication, and coordination centres. To fulfil their tasks, conditions that are as suitable as possible for the planning and organization of activities need to be created. The organizational structure of the staff must also ensure and enable the issuing of tasks and cooperation with the state security forces in operation. For this, a constant and reliable supply of electrical power must be ensured [10]. Similar designs are also the goal of NATO initiative to reduce energy consumption of deployable camps [17]. For the design, optimization and simulation of the proposed PV system, a model of a command centre using a standard army tent was devised. Similar designs are also the goal of NATO initiative to reduce energy consumption of deployable camps. A list of electrical appliances for the needs of the command centre was created to simulate the load using PV\*Sol database. The average total consumption of the mobile command centre per day was calculated as 55.73 kWh.

Table 1. Command centre electricity consumption per day.

Appliance	kWh/day
Electric kettle	0.56
Transmitters + chargers	10.98
Lights	1.10
Notebooks	36.43
Printer	5.23
Projector	1.43
Total	55.73

In total two designs were created for this scenario – with and without a backup generator. The solutions were designed with the aspect of mobility in mind. Thus, a solution using mobile trailers carrying the technology was used. A visualisation of a possible trailer design can be seen in Figure 5.

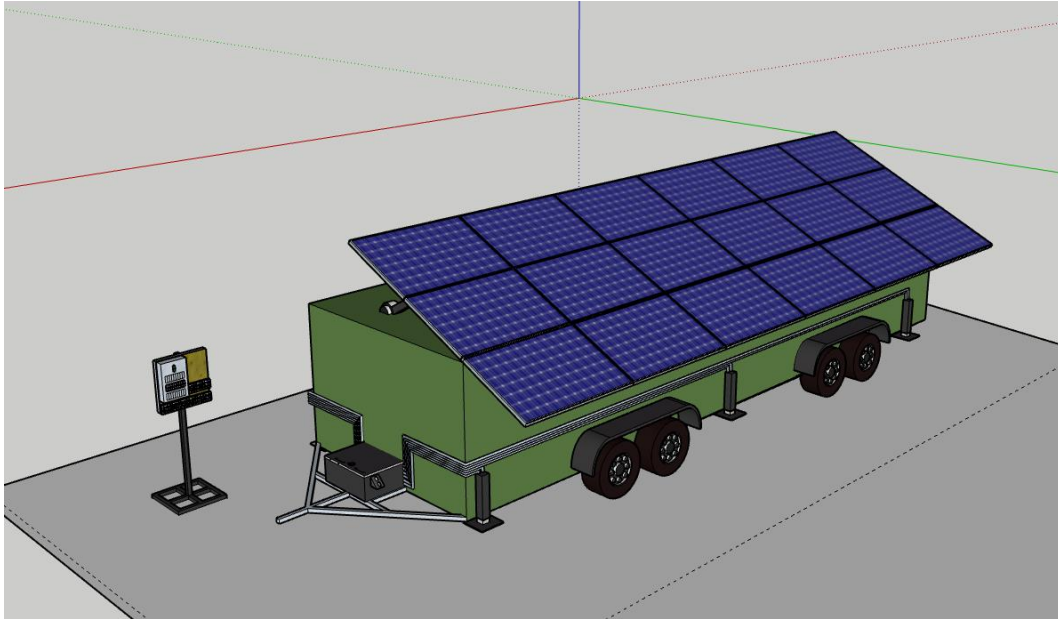

Figure 5. Visualisation of a mobile PV system trailer. *Source: Own.*

The first proposed system consists of one-phase inverters (GoodWe GW5048D-ES), AXITEC Li-ion batteries with a total capacity of 60.4 kWh and 18 pcs. of CanadianSolar HiKu7 CS7L-600 [15] 600 Wp solar panels. This is coupled with an army standard 4 kW/ 230 V generator that is operating when the energy produced from the sun is not enough to provide for the command centre. Visualisation of this design can be seen in Figure 6.



Figure 6. Visualisation of a PV system with a backup generator. *Source: Own.*

The main goal of the second design was to achieve full self-sufficiency of the command centre without the use of a generator. To achieve this, a total of 48 pcs. of PV panels needed to be used, along with a third inverter, and 16 batteries with a total capacity of 161 kWh. Due to the lack of a generator providing grid parameters, off-grid inverters (Fronius Simo 8) were used. This design eliminates the reliability of the command centre on fossil fuels, however, the space for the installation of such a system and the initial investment is much higher. The visualisation of the second proposed design can be seen in Figure 7.

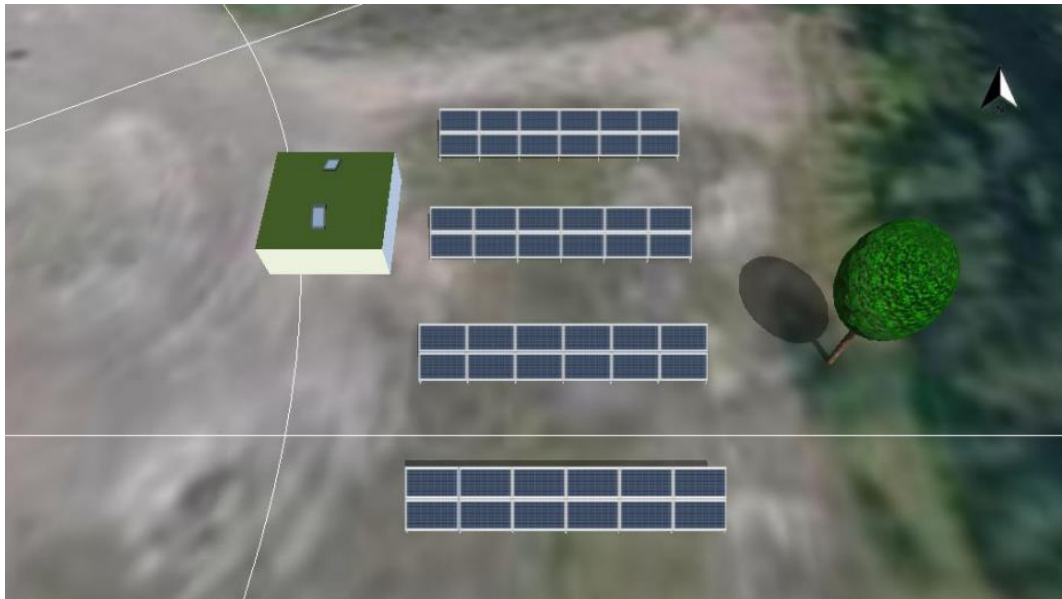

Figure 7. Visualisation of a fully photovoltaic system. *Source: Own.*

### Results and discussion

Although the orientation and the tilt of PV panels have a significant effect on their efficiency and electricity production throughout the day [18], it may be easier sometimes to mount the panels in less favourable orientations (i.e. rooftop-mounted systems). Such systems then should be optimized through the technology used, battery capacity or consumption regulation, which may also assist in better solar energy utilization [19]. The main advantage of using simulation software is the amount of data that can be used to evaluate the benefits of the proposed designs beforehand. Based on the data from the simulations, the designs can be amended and optimized without any additional work. This also enables us to evaluate various conditions, such as the simulation of a blackout in the winter months. In mobile systems, we can use simplified calculation tools when placing the PV panels to ensure maximal efficiency based on the geographical place and time of year. Notable differences in the utilization of solar energy in different geographical locations can be observed in [20].

#### Automated warehouse scenario

Even though the used software lacks some simulation functions for a precise PV system with generator simulation, the created 3D design of a grid-tied system enabled us to account for losses and other influences on the system. The simulation was run as an on-grid system to simulate normal operations and then as an off-grid system to simulate power grid failure and get data about the backup generator usage in three days period with the lowest solar irradiation (21st-24th December) and the highest solar irradiation (22nd-25th June). The results of the simulation can be seen in Figure 8 below. Two parameters important for the design of a PV system are Own Power Consumption and Solar Fraction. The proposed PV system generates approximately 531 MWh/year. The Own Power Consumption parameter tells us that 58.4% of it is used to power the facility and charge batteries, while the rest is sent to the grid. On the other hand, the Solar Fraction parameter is related to the consumption and, in our case, tells us that 72.7% of the electric energy consumption was supplied by the PV system.

The use of PV energy throughout the year is shown in Figure 9, where the generated energy surplus, especially in May-September, can be observed. This surplus occurs due to the amount of generated energy in days with lower consumption, as well as better irradiation conditions in the summer months in the Czech Republic. As this surplus of energy can be fed into the public grid and sold, it contributes to a faster return on the initial investment. We can also observe significant drop in the amount of generated power as the conditions during late autumn and winter are not satisfactory for PV systems. This, coupled with additional power consumption (e.g., heating), may in some situations prove the need of hybrid systems utilizing wind turbines, to be fully self-sufficient. Other methods of compensation for lower production and higher consumption, apart from the distribution grid, may be consumption regulations with the use of weather (and solar energy availability) forecasts [19].

**PV System**

PV Generator Output	492.00 kWp
Spec. Annual Yield	1 079.94 kWh/kWp
Performance Ratio (PR)	89.38 %
Yield Reduction due to Shading	2.1 %/Year
PV Generator Energy (AC grid)	531 435 kWh/Year
Direct Own Use	185 470 kWh/Year
Battery Charge	125 198 kWh/Year
Down-regulation at Feed-in Point	0 kWh/Year
Grid Feed-in	220 934 kWh/Year
Own Power Consumption	58.4 %
CO <sub>2</sub> Emissions avoided	245 403 kg / year

PV Generator Energy (AC grid)

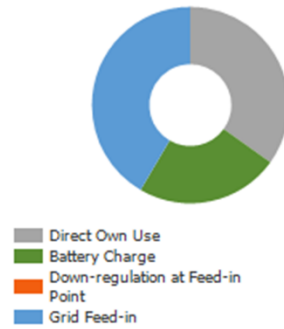

**Appliances**

Appliances	415 000 kWh/Year
Standby Consumption (Inverter)	103 kWh/Year
Total Consumption	415 103 kWh/Year
covered by PV power	185 470 kWh/Year
covered by battery net	116 540 kWh/Year
covered by grid	113 260 kWh/Year
Solar Fraction	72.7 %

Total Consumption

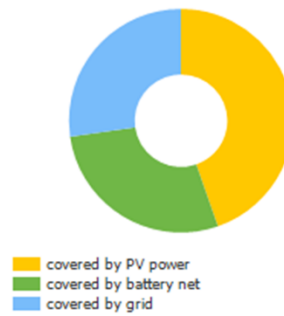

Figure 8. Simulation results (PV\*Sol). Source: Own.

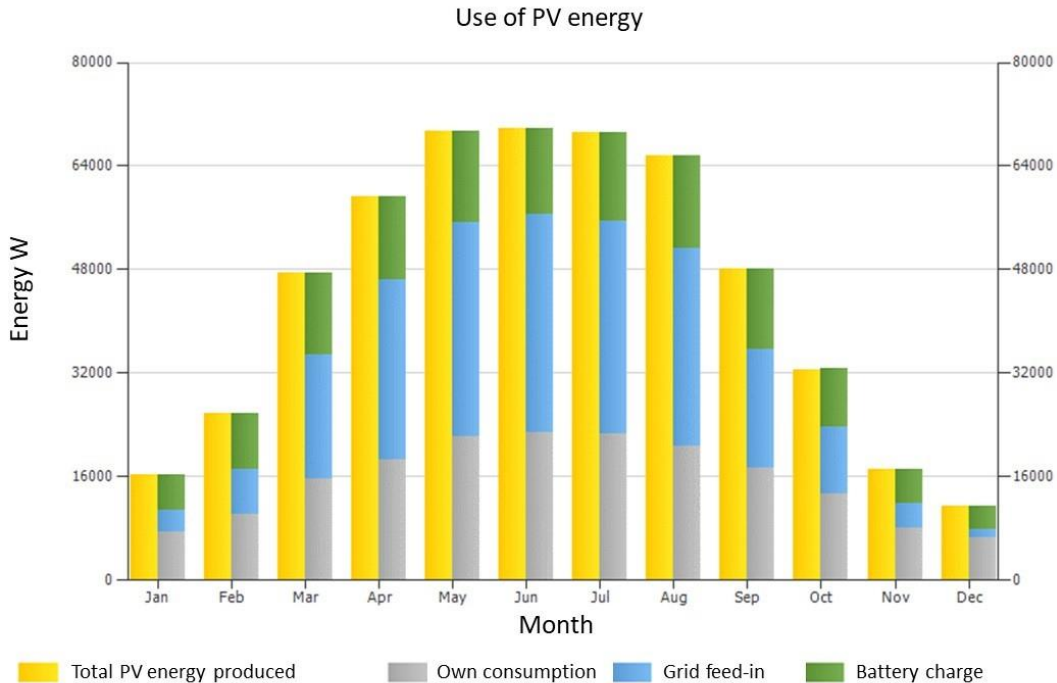

Figure 9. Graph of the use of PV energy in the warehouse (PV\*Sol). Source: Own.

The use of backup generators, compared to solar energy, in simulated power grid failure on the days with the lowest irradiation is shown in Figure 10. We can observe a high utilization of the backup generator to cover the warehouse consumption, especially due to insufficient sunlight and short days. However, we can also see

that the system is capable of covering part of the consumption with photovoltaic energy even at a relatively small intensity of irradiation around  $270 \text{ W/m}^2$ . On the other hand, relatively low utilization of the backup generator is needed during days with high irradiation. In Figure 11, we can see a simulation of the system during June. With irradiation of around  $850 \text{ W/m}^2$ , it is apparent that the generator is used only to upkeep the minimal state of charge (SOC) of the batteries and that the system is capable of supplying the warehouse with enough power to ensure its operation.

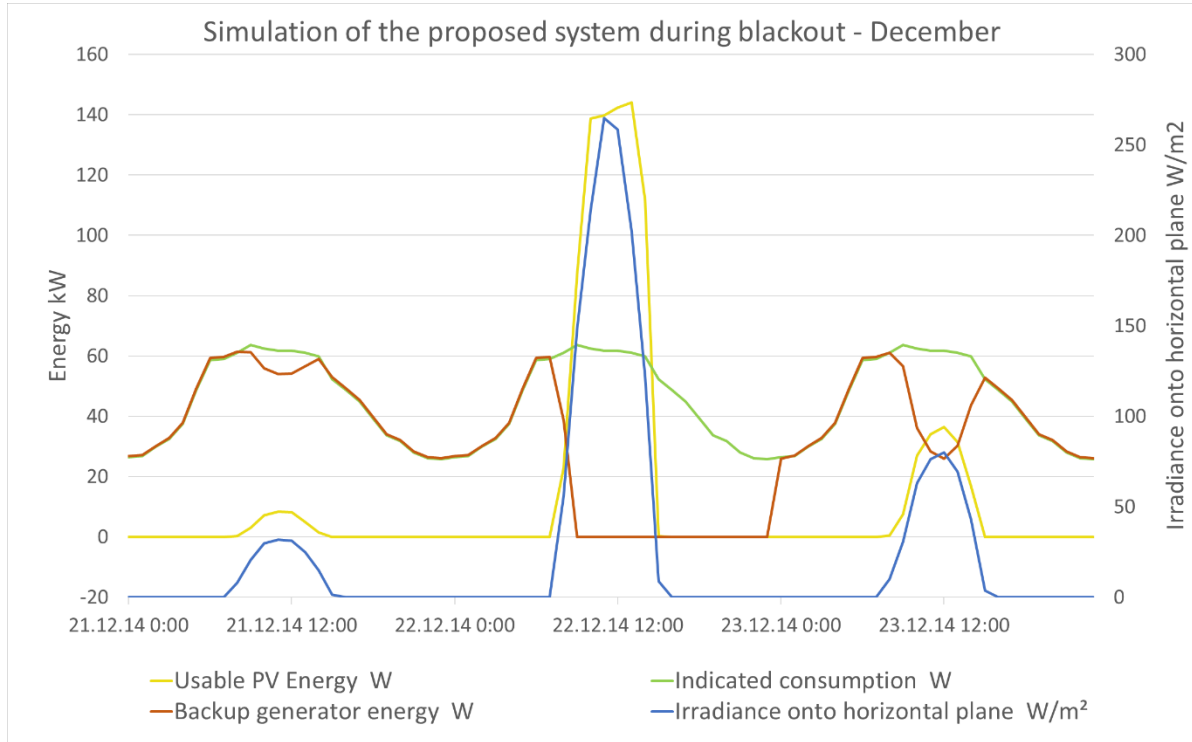

Figure 10. Use of backup generator during low-irradiation days (PV\*Sol). Source: Own.

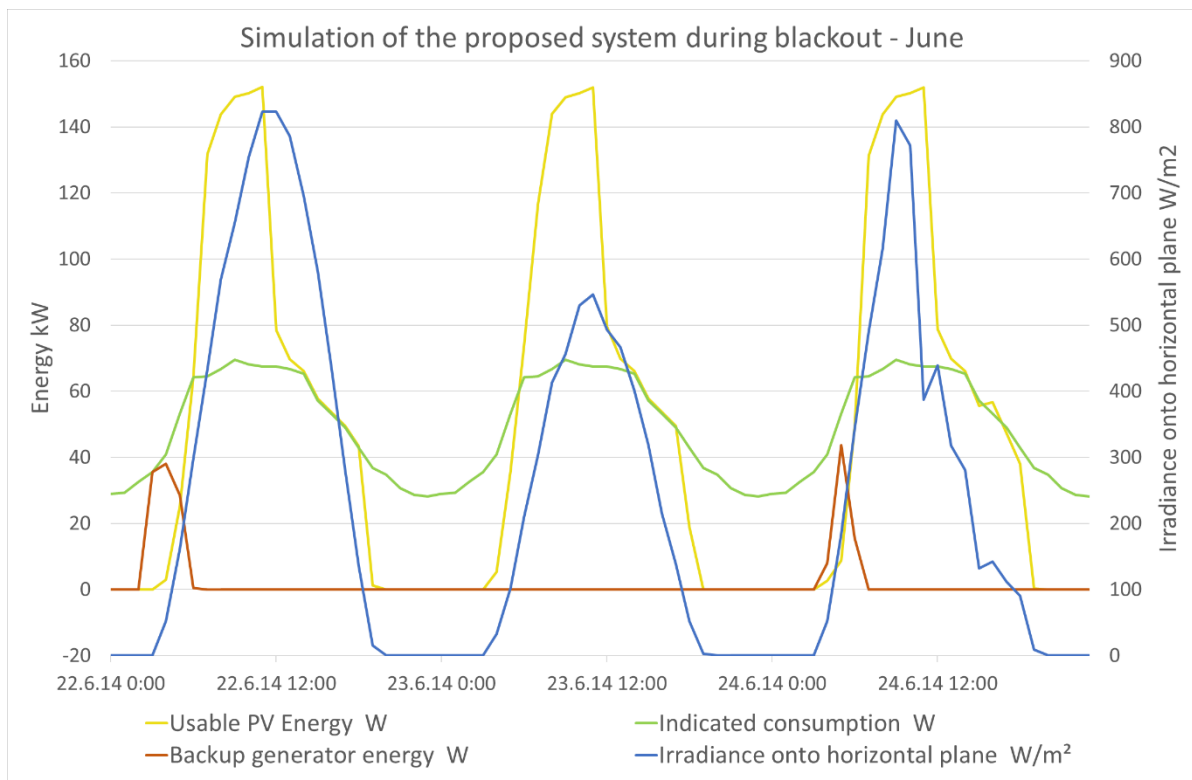

Figure 11. Use of backup generator during high-irradiation days (PV\*Sol). Source: Own.



### Mobile command centre scenario

As mentioned before, an interval of 6 months was used (April – September) for the simulation of the design for mobile command centre. Firstly, the simulation for the design with a backup generator was run. Based on the results of this simulation, the system was optimised and then we designed and simulated the PV-only system.

As we can observe from the results of the simulation below, the total consumption of the command centre over our interval would be 10 MWh. From this consumption, 68.3% would be covered using solar energy with the rest would be covered by the backup generator. This would mean estimated consumption of 2 235 L of fuel, or on average, 12.5 L / day.

#### Appliances

Consumption	10 078 kWh/Year
Consumption with Load Shedding	10 078 kWh/Year
Standby Consumption (Inverter)	3 kWh/Year
Cable Losses	0 kWh/Year
Total Consumption	10 081 kWh/Year
covered by PV power	4 029 kWh/Year
covered by battery	4 623 kWh/Year
covered by auxiliary generator	1 430 kWh/Year
Solar Fraction	69.0 %

Total Consumption



■ covered by PV power  
■ covered by battery  
■ covered by auxiliary generator

Figure 12. PV system with backup generator simulation results (PV\*Sol). *Source: Own.*

#### PV System

PV Generator Output	28.80 kWp
Spec. Annual Yield	1 079.07 kWh/kWp
Performance Ratio (PR)	87.98 %
Yield Reduction due to Shading	5.3 %/Year
Maximum possible PV Energy	31 116 kWh/Year
Usable PV Energy	11 502 kWh/Year
Coverage of Consumption	5 122 kWh/Year
Battery Charge	6 380 kWh/Year

Usable PV Energy



■ Coverage of Consumption  
■ Battery Charge

#### Appliances

Consumption	10 078 kWh/Year
Consumption with Load Shedding	10 078 kWh/Year
Standby Consumption (Inverter)	39 kWh/Year
Cable Losses	0 kWh/Year
Total Consumption	10 117 kWh/Year
covered by PV power	5 122 kWh/Year
covered by battery	4 994 kWh/Year
Solar Fraction	100.0 %

Total Consumption



■ covered by PV power  
■ covered by battery

Figure 13. Stand- alone PV system design simulation result (PV\*Sol). *Source: Own.*

Further optimization of this system would require additional batteries and a trade-off between their longer lifespan and set parameters of maximal discharge of the batteries, as the possibility to effectively use more of

their stored energy (the simulated setting was max 80% SOD) would require less generator usage. Correct spacing between the construction, panel orientation and their tilt would also have to be adhered to during the system installation as this could create losses in power production due to shading. The fully photovoltaic solution for the mobile command centre design (Figure 13) had to be scaled to account for the need to supply enough power even in inconvenient conditions. The simulation of the design showed us that the system would be around 32% efficient should the setup be used for the whole duration of the 6-month interval. On the other hand, it also proved that the system would be capable of energy self-sufficiency even in sustained adverse conditions (PV\*Sol calculated 4.7 days of autonomy).

### Impact

The presented paper deals with the design of photovoltaic systems as renewable energy sources and their use in specific applications to substitute fossil fuel energy sources (partially or fully). The presented designs are based on practical scenarios and lay the basis for future applications and development. The main impact is environmental, as we aimed to increase energy self-sufficiency in both presented scenarios. Not only do these designs reduce the dependability on fossil fuel use, but they also enable further development in the problematics, especially regarding mobile applications. Another environmental impact is the reduction of emissions due to using renewable energy sources. Based on the PV\*Sol simulations, the utilization of the photovoltaic system for strategic warehouse would avoid generating approx. 245 t of CO<sub>2</sub> emissions per year. The mobile photovoltaic systems would avoid generating approx. 17 kg (backup generator design) and 22 kg of CO<sub>2</sub> emissions per day of operation. This would support the initiatives for renewable energy sources and declining trend of CO<sub>2</sub> emissions in Europe [21]. Although energy and resources are required to manufacture the technology for PV systems, their operation produces this energy back (without emissions) multiple times over the life cycle of the PV system [22,23]. The mobile applications have also the impact of lesser, or fully eliminated noise pollution as opposed to regular use of generators as a source of power. Lower dependability on fossil fuels and energy self-sufficiency also has an economic impact on both presented scenarios. For the designs used for critical infrastructure, the overall cost of energy for the general operations of the facilities is greatly reduced, especially in times of crisis, such as economic crisis or the current energy market crisis. For mobile applications, photovoltaic systems promise a reduction in the cost of fossil fuels that would be otherwise necessary for energy production. Exact economic impact would vary mainly with geographical location of the installed system. As the availability of solar energy and its effective usage reduces with the distance from the equator, countries closer to the equator would see larger energy output from the same system than e.g. Nordic countries [20]. Thus, the geographic location should be taken into consideration during the design of the photovoltaic system as it impacts its overall efficiency and economic impact (return of investment, rentability). With the mobile photovoltaic system, this could be overcome by modularity of the system, i.e., scaling the system based on the specific locations and their availability of solar energy. Simulations of the designs in both scenarios brought results similar to other studies on the topic [3,7–9,19].

From a social point of view, the proposed designs aim at sustainable energy sources for the future. The designs present assurance in the form of reliable energy sources for critical infrastructure, as well as for mobile command centres in both military and civil sectors. Especially the designs of photovoltaic systems for mobile applications are already impacting the integrated rescue system of the Czech Republic, as there is an effort aimed at practical applications of such systems. These could be used in medium to long-term operations during and following natural disasters (i.e., provisory shelters, energy source during the disaster clean-up and debris removal operations), for mobile hospitals (e.g., during COVID pandemic) or for refugee camps, where clean source of energy (i.e., without the noise pollution from generators) may be favoured. Specifically modular and scalable systems may impact such operations of the integrated rescue forces even during their assistance abroad.

### Conclusions

To evaluate the possibility of the use of solar energy as a source of electricity in strategic applications and mobile applications, two scenarios were discussed and created. After this, many aspects of the scenarios (Automated warehouse, mobile command centre) were analysed to design an optimized photovoltaic system to ensure a reliable source of power as well as self-sufficiency in the events of blackout. For both scenarios, 3D models and visualisations were created. The proposed systems were optimised and simulated using PV\*Sol software. The first scenario presented a central warehouse with significant strategic importance to Czech Army Forces and NATO forces. Due to the automatization of the facility and its importance as one of the few central warehouses of the Czech Armed Forces, a grid-tied PV system with an emergency backup generator was designed. The system was designed with a backup generator in mind to ensure the functioning of the system even in the case of power grid failure. PV\*SOL software was used for the 3D design and simulations. The

simulation showed us that the proposed system design fits the needs of the facility as it can cover approximately 71% of the warehouse energy consumption. However, due to the varying conditions of irradiation in winter and summer, approximately 40% of the generated energy would be sent to the grid. Although this energy could be sold, the system could be optimized by installing larger capacity energy storage. This would not be an issue as the system is easily scalable. Based on the simulations of blackout we found out that the system is fully able to function with the use of a 60 kW backup generator to ensure the functioning of the facility. In the second scenario, two designs of PV systems for mobile command centres were designed and simulated. Firstly, a system with the use of a backup generator was proposed. Such a system not only has a lower initial investment but is also significantly smaller and allows for easier transport than a fully PV system. The second design of a fully PV system proved to be able to support a mobile command centre using only solar energy, however, this comes with a few downsides. Namely the need for a larger system due to the need to supply enough power even in unfavourable conditions. With this comes not only transportation issues but also the higher initial cost of the system (even though the operating cost is lower). The analyses of the scenarios and simulations of the proposed systems showed us the possibilities of implementing renewable sources of energy not only in strategic applications but also in mobile applications. The results of the simulations are also comparable with results of similar researches [3,7–9,19]. A benefit for further research would be case studies, mainly aimed at the mobile command centre scenario, as this practical solution could be used in both military and civil sectors, especially with a focus on the integrated rescue system and its operations. Further research could also be aimed at the capabilities of such systems during winter months, when the energy output of solar system is notably reduced. Data measured this way (during real application) could also help with further optimising the proposed design and lead to the basis of fully modular designs that could be adjusted for specific needs and situations, such as operations of the integrated rescue system regarding a refugee crisis, refugee camps or natural disasters.

#### Conflict of interest

There are no conflicts to declare.

#### Acknowledgments

This work was supported by the specific graduate research of the Brno University of Technology No. FEKT-S-14-2293 and the Ministry of Defence of the Czech Republic project No. DZRO K-109, project. No. OFVVU20140001. This research work has been conducted in the Centre for Research and Utilization of Renewable Energy (CVVOZE). The authors gratefully acknowledge financial support from the Ministry of Education, Youth and Sports of the Czech Republic under the NPU I Programme (project No. LO1210).

#### References

- [1] K.A. Makinde, O.B. Adewuyi, A.O. Amole, O.A. Adeaga, Design of Grid-connected and Stand-alone Photovoltaic Systems for Residential Energy Usage: A Technical Analysis, *J. Energy Res. Rev.* (2021) 34–50. <https://doi.org/10.9734/jenrr/2021/v8i130203>.
- [2] Renewable Energy Market Update, *Renew. Energy Mark. Updat.* (2022). <https://doi.org/10.1787/faf30e5a-en>.
- [3] S. Qazi, Mobile Photovoltaic Systems for Disaster Relief and Remote Areas, in: *Standalone Photovolt. Syst. Disaster Reli. Remote Areas*, Elsevier, 2017: pp. 83–112. <https://doi.org/10.1016/b978-0-12-803022-6.00003-4>.
- [4] Solární Asociace, Mobilní Alfons dodává elektřinu ze slunce nejen armádě, (2015). <https://www.solarniasociace.cz/cs/aktualne/2838-mobilni-alfons-dodava-elektrinu-ze-slunce-nejen-armade>.
- [5] Multicon Solar container, (2022). <https://solarcontainer.info/home-2/energy-power-rack.html>.
- [6] J. Šiška, Solární proud (nejen) pro německou armádu.
- [7] K. Prompinit, B. Plangklang, S. Hiranvarodom, Design and construction of a mobile PV hybrid system prototype for isolated electrification, *Procedia Eng.* 8 (2011) 138–145. <https://doi.org/10.1016/j.proeng.2011.03.025>.
- [8] A. Borodinecs, D. Zajecs, K. Lebedeva, R. Bogdanovics, Mobile Off-Grid Energy Generation Unit for Temporary Energy Supply, *Appl. Sci.* 12 (2022) 673. <https://doi.org/10.3390/app12020673>.
- [9] J. Franceschi, J. Rothkop, G. Miller, Off-grid solar PV power for humanitarian action: From emergency communications to refugee camp micro-grids, *Procedia Eng.* 78 (2014) 229–235. <https://doi.org/10.1016/j.proeng.2014.07.061>.
- [10] J. Černý, Organizační a velitelské struktury a jejich vliv na organizaci velení a řízení vojsk u brigádního úkolového uskupení, *Econ. Manaement.* 02/2010 (2010).
- [11] K. Lewczuk, M. Kłodawski, P. Gepner, Energy consumption in a distributional warehouse: A practical case

- study for different warehouse technologies, *Energies*. 14 (2021) 2709. <https://doi.org/10.3390/en14092709>.
- [12] U.S. Energy Information Administration, COMMERCIAL BUILDINGS ENERGY CONSUMPTION SURVEY (CBECS): Table PBA4. Electricity consumption totals and conditional intensities by building activity subcategories, (2012). <https://www.eia.gov/consumption/commercial/data/2012/c&e/cfm/pba4.php>.
- [13] Fenix Group, Elektrické vytápění při revitalizaci průmyslových objektů, (2012).
- [14] Solar+Diesel Generator Solution, (2022). <https://pl.goodwe.com/solar-diesel-generator-solution>.
- [15] CanadianSolar solar panel datasheet, (2022). [https://static.csisolar.com/wp-content/uploads/2020/10/06153233/CS-Datasheet-HiKu7\\_CS7L-MS\\_v2.4\\_EN.pdf](https://static.csisolar.com/wp-content/uploads/2020/10/06153233/CS-Datasheet-HiKu7_CS7L-MS_v2.4_EN.pdf).
- [16] GoodWe MT series datasheet, (2022). [https://en.goodwe.com/Ftp/EN/Downloads/Datasheet/GW\\_MT\\_Datasheet-EN.pdf](https://en.goodwe.com/Ftp/EN/Downloads/Datasheet/GW_MT_Datasheet-EN.pdf).
- [17] Nato, New NATO scientific project to reduce energy consumption of deployable camps, (2018).
- [18] T.M. Yunus Khan, M.E.M. Soudagar, M. Kanchan, A. Afzal, N.R. Banapurmath, N. Akram, S.D. Mane, K. Shahapurkar, Optimum location and influence of tilt angle on performance of solar PV panels, *J. Therm. Anal. Calorim.* 141 (2020) 511–532. <https://doi.org/10.1007/s10973-019-09089-5>.
- [19] O. Shavolkin, I. Shvedchykova, J. Gerlici, K. Kravchenko, F. Pribilinec, Use of Hybrid Photovoltaic Systems with a Storage Battery for the Remote Objects of Railway Transport Infrastructure, *Energies*. 15 (2022) 4883. <https://doi.org/10.3390/en15134883>.
- [20] L. Zhang, Z. Chen, H. Zhang, Z. Ma, B. Cao, L. Song, Accurate study and evaluation of small PV power generation system based on specific geographical location, *Energy Eng. J. Assoc. Energy Eng.* 117 (2020) 453–470. <https://doi.org/10.32604/EE.2020.013276>.
- [21] M. Roser, H. Ritchie, CO<sub>2</sub> and Greenhouse Gas Emissions - Our World in Data, Our World Data. (2020). <https://ourworldindata.org/co2-and-other-greenhouse-gas-emissions#future-emissions>.
- [22] K. Komoto, H. Uchida, M. Ito, K. Kurokawa, A. Inaba, Estimation of energy payback time and CO<sub>2</sub> emission of various kinds of pv systems, in: 23rd Eur. Photovolt. Sol. Energy Conf. Exhib., 2008: pp. 3833–3835.
- [23] M. Simón-Martín, M. Díaz-Mediavilla, C. Alonso-Tristán, T. García-Calderón, M.C. Rodríguez-Amigo, Grid Connected PV Systems: Energy Payback Time Analysis, in: 5th Int. Conf. Sustain. Energy Environ. Prot., Dublin, 2012: pp. 174–179. <https://doi.org/10.13140/2.1.5180.6089>.