

Extending Value Stream Mapping for Lean Production Planning and Control

Hendrik Van LANDEGHEM , Johannes COTTYN

Industrial Systems Engineering and Product Design, Ghent University, Belgium

Received: 14 February 2022

Accepted: 16 August 2022

Abstract

Value Stream Mapping has been a key Lean tool since its publication in 1988, offering a strategic view on the reconfiguration of an organization's processes to reduce overall lead time. It has since been used in many different domains beyond (car) manufacturing. However, the potential offered by its concise representation of both material flow and its controlling information flow seems to have been largely underused. Most literature reports on VSM in the context of waste detection and local improvements. VSM also supports redesigning the material flow (even on a supply chain level) towards (pure) pull systems.

However, it fails to adequately give guidance on how to gradually evolve towards this ultimate ideal state. This paper wants to offer a significant contribution to practitioners on how to use VSM to bridge this gap. Another key challenge that remains largely unpublished is how to adapt the planning systems accordingly at each reconfiguration of the material flow.

This paper presents extensions to the basic VSM tool to meet these challenges. It includes a more comprehensive 5-level hierarchy that allows to position most lean flow-related techniques. It also extends the basic "door-to-door" VSM with new symbols to accommodate these techniques into the map. Finally, it introduces a new set of 13 questions to support redesigning not only the material flow, but also the information flow. The resulting richer future state maps better support the gradual evolution towards a leaner future shop floor, as illustrated with an example.

Keywords

Value stream mapping, Production planning and control, Lean, Supply chain.

Lean Production Planning and Control

The domain of Production Planning and Control has been well documented. The de facto standard of PPC systems architecture, to which most ERP systems adhere, goes back to the legacy of MRP I and II systems, as described by Whybark and Vollman (Jacobs et al., 2018). The relentless promotion of it through certification by the Association for Supply Chain Management (formerly APICS) has led to a proliferation of this type of PPC throughout production companies around the world since 2000 onwards.

Since then, the rollout of Lean Management principles in industry has introduced many new techniques for reducing production lead times, by improving the flow of materials. They are designated as PULL sys-

tems, to oppose their logic to the centralized PPC systems, labelled PUSH. Kanban, Polca (Bicheno & Hollweg, 2016) are techniques that provide production orders with specific timings directly to the shopfloor, thereby often interfering with the orders generated by the PPC system. Since these PULL methods reduce production lead times considerably, the gap with the timings from the PULL production plan increases to the point of destroying its validity. This leads to confusing delivery time information for the customers, missed synchronization between consecutive production stages and both material shortages and surplus, as noted as early as 1989 (Karmarkar, 1989).

The methods we incorporate in this paper are based on the list in (Stevenson et al., 2005) which covers the most common PUSH and PULL methods. We list them in Table 1 and indicate for each literature references containing a detailed description.

From literature (among others, Stevenson et al., 2005; Ulewicz et al., 2016) one increasingly notices a growing confusion among practitioners on several issues regarding the proper use of PUSH and PULL methods:

Corresponding author: H. Van Landeghem – Industrial Systems Engineering and Product Design, Ghent University, Belgium, e-mail: hendrik.vanlandeghem@ugent.be

© 2022 The Author(s). This is an open access article under the CC BY license (<http://creativecommons.org/licenses/by/4.0/>)

Table 1
Overview of PUSH/PULL PPC methods

PUSH	MRP	The MRP II method calculates detailed production orders, starting from a Master schedule, using a multi-level Bill of Material (BOM) to identify components needed and their current inventory to determine the amount to produce (Jacobs et al., 2018). It includes Order entry and demand management modules, making it the de facto standard PPC. Besides the BOM, it also uses linear lists of single operations (routings) for capacity calculations and order tracking.
	DDMRP	Demand Driven MRP puts buffer inventories at intermediate BOM levels and calculates production quantities using inventory control methods (Ptak & Smith, 2019). It augments the MPS/MRP function of MRP II.
	Scheduling	Different algorithmic approaches to calculate detailed production orders for each work center within their respective capacity (Lopez & Roubellat, 2008). It uses a network model of single machine operations.
	ToC	Theory of Constraints is a scheduling method that calculates detailed production only for the bottleneck work centers (Goldrath & Cox, 2014). Its buffer control qualifies as PULL.
PULL	Kanban	Physical material inventory, limited by Kanban cards that also serve as standard replenishment orders when a bin of the inventory is consumed (Bicheno J., Hollweg, 2016)
	POLCA	POLCA cards represent generic capacity of a work cell. It is a card based flow control method, using one step look-ahead to steer flow towards work centers with immediate spare capacity (Suri, 2018)
	Workload Control	Probability based capacity loading calculations that determine which production orders to release to their next workstation (Wiendahl, 1994)
	CONWIP	Card or signal based method that keeps a CONstant Work In Process within its control loop by equating a card with a job and limiting the total number of cards (Bicheno J., Hollweg, 2016)
	Heijunka	Load leveling mechanism (often through physical pigeon hole racks) for releasing orders into a work center of department (Bicheno J., Hollweg, 2016)
	Visual management	Any method that relies on visual cues (such as position within painted squares) to determine what to produce next (Bicheno J., Hollweg, 2016). Includes less formal methods, such as supervisor discretion.
	Local rules	Any sequence rule applied to the work order queue before a workstation, such as FCFS, earliest due date, shortest processing time, (Lopez P. & Roubellat, 2008)
	FIFO	Physical queue of orders, strictly conserving a First In First Out sequence, with limited storage capacity, which – once full – halts the upstream process (Bicheno J., Hollweg, 2016)

- what is the scope of each method within the overall planning architecture?
- how can PUSH and PULL methods be integrated seamlessly into a lean PPC architecture?
- how can one (re)design its PPC architecture to bring it in line with the shopfloor changes resulting from Lean continuous improvement actions?

This paper introduces a comprehensive 5 level architecture which allows to position each PPC system and understand their respective scopes. We argue (with (Stevenson et al., 2005)) that an effective PPC architecture (i.e., one which maximizes due date adherence) should cover all 5 functional levels within the firm. This scheme supports the design decisions made when lean changes to the shopfloor require alterations to the existing PPC system.

To further guide this redesign effort, we turn to the Value Stream Method. This Lean tool is unique in that it models both the material flow configuration and the information flow by which it is controlled.

Value Stream Mapping, misunderstood and underused

Value Stream Mapping as a Lean tool entered the mainstream with the publication of (Rother, 1999). VSM at its origin was designed for a well delineated purpose: visualizing the key components of the total production lead time (i.e., the inventory locations), and the factors that led to it: flow interrupting behavior of processes and control methods (setup times, breakdowns, quality errors, MRP batching rules, ...). VSM contains some unique characteristics, not found in other analysis schemes from that time:

1. It situates itself on a meso-level, focusing on one value stream running “door-to-door” from a factory perspective, offering a long-needed trade-off between capturing the key information about causes of long lead times, while avoiding too much detail that thwarts any insight.

2. It includes in the same diagram both the material flow and the PPC information system with its information flows: market information, internal production orders and the purchasing orders sent to suppliers, supplemented by key process characteristics and lead time chart.
3. It offers an 8-step analysis to design new future states from the current one.

VSM thereby allows not only find the causes of inventory points along the material flow, but also to reconfigure the shopfloor towards a more pull driven operation. As such it positioned itself as a strategic tool for organizations to think about this reconfiguration. VSM also was key to show the potential of short lead times and hence high flow efficiency, whereas before only resource efficiency was mainly seen to drive improvement projects (Modig & Alhström, 2012).

However, when one examines the published results on VSM use, one finds overwhelmingly that its use is limited to waste detection only, based on the current state. We found from own research (Van Landeghem et al., 2018) that companies largely fail to move from local improvements (phase 1) into the flow and pull improvements (phase 2). We believe that failure to grasp the potential of VSM and its subsequent under-use are an important factor in this.

The VSM has proven to be a real strategic tool, helping organizations worldwide, and far beyond manufacturing alone, to map out how to improve their existing processes towards the ideal one-piece-flow state (see Acero et al., 2020) for an overview).

To enhance the decision power derived from VSM analysis, one also increasingly links VSM information with optimization methods (Annamalai, 2020) or simulation (Stadnicka & Litwin, 2019).

Other researchers have come to similar conclusions about different potential uses of VSM and have proposed enhancements to it. Some of the key publications in this regard, according to the authors, are listed below:

Oberhausen and Plapper (2017) extend VSM to multiple enterprises within a supply chain, thereby introducing a rich set of performance indicators to support analysis on this level. The paper also introduces 4 hierarchical levels of analyzing cross-enterprise networks, highlighting the recursiveness of network analysis and its subsequent need to expand the one level “door to door” of basic VSM.

Busert and Fay (Busert & Fay, 2019) supplement VSM with I4.0 capabilities in order to enhance the quest for improvement with more detailed and up to date process information for the control systems. They note – however without further elaboration – that “Suitable production control methods have to

be selected and/or adapted under consideration of requirements and capabilities of the considered process steps”. This paper aims at providing a design framework to support just that.

Gargalo et al. (2021) provide an excellent overview of VSM enhancements in different domains, while focusing on additions to prepare VSM for sustainability analysis of material flows.

PPC architecture in a Lean environment

A 5 level architecture

The key to understanding the scope of the methods listed in Table 2 is to position them on a comprehensive framework, that clarifies which function(s) they offer to the PPC architecture. Table 3 compares our 5 levels, with 2 additional levels of control near the shopfloor, with both APICS and traditional VSM schemes.

Table 2
PPC hierarchical levels

	This paper	APICS	VSM
Sales & Operations planning		x	
Master planning	(x)	x	
Detail planning	x	x	x
Shop floor control	x	x	x
Flow control	x		
Local control	x		

Each level has its own purpose in the overall PPC architecture (adapted from Stevenson et al., 2005):

Sales & Operations planning strategically plans future product lines and production capacity based on market forecasts and trend predictions. It is only loosely coupled with the other levels and is part of all architecture. Therefore, it is outside the scope of this paper.

Master planning decides on the planning parameters for the next couple of months based on incoming customer orders and forecasts, with limited deviation from the available capacity infrastructure. It basically sets the level of final products that will be produced, with target inventory levels (in an MTS situation) or backlog levels (within MTO).

Detail planning converts the quantities of final product from the Master plan into detailed production and purchasing orders, according to a specific shop floor model and algorithm. (DD)MRP uses the BOM and lead times for this, while Scheduling adopts

a network model of operations, which a finite capacity algorithm assigns to machines.

Shop floor control launches and tracks the status of production orders along their routing through the shop floor. It also tracks the input/output material balance across the shop. SFC therefore has an important role on shop floor loading and its WIP.

Flow control imposes a coordination mechanism to avoid excessive buffer stocks, to improve flow and reduce production lead time. It provides a triggering mechanism, that does not alter production orders from higher levels.

Local control triggers the sequence and start of production for orders waiting before the production unit (which can be at the workstation, cell or pure job shop level).

Figure 1 shows where these levels occur on the VSM map, using an example from (Lopez P. & Roubellat, 2008). While Master planning is not a visible part of the map, it does set the operating parameters (such as operating hours, capacity, target stock levels, ...) that are featured in the data boxes of the VSM. While important, this level is not further discussed for sake of focus and clarity.

We can now link the PPC methods to this 5-level framework, to guide us in composing our PPC architecture to cover all levels (Table 3).

In designing the PPC architecture, the collection of methods adopted must cover all levels. When two methods both address the same level, one must choose which one will take the lead, and suitably reconfigure the other so not to issue confusing information to the shop floor. While in theory most combinations

Table 3
The functional scope of the PPC Methods

PPC Method	Master Planning	Detail Planning	Shop floor control	Flow control	Local control	Degree of WIP control
MRP(a)						L
MRP(b)						M
DDMRP(b)						L
Scheduling						T
ToC						M
Kanban						T
POLCA						M
Workload Control						M
CONWIP						M
Heijunka						T
Visual management						L
Local rules						L
FIFO						T

MRP(a): configured with multi-level BOM, and routings at workcenter level

MRP(b): configured with flat BOM, and routings at cell level

WIP control: (L)ow, (M)edium, (T)ight

are possible, in practice one finds some recurring architectures (Stevenson et al., 2005):

1. MRP + CONWIP + local control, to control a pure job shop

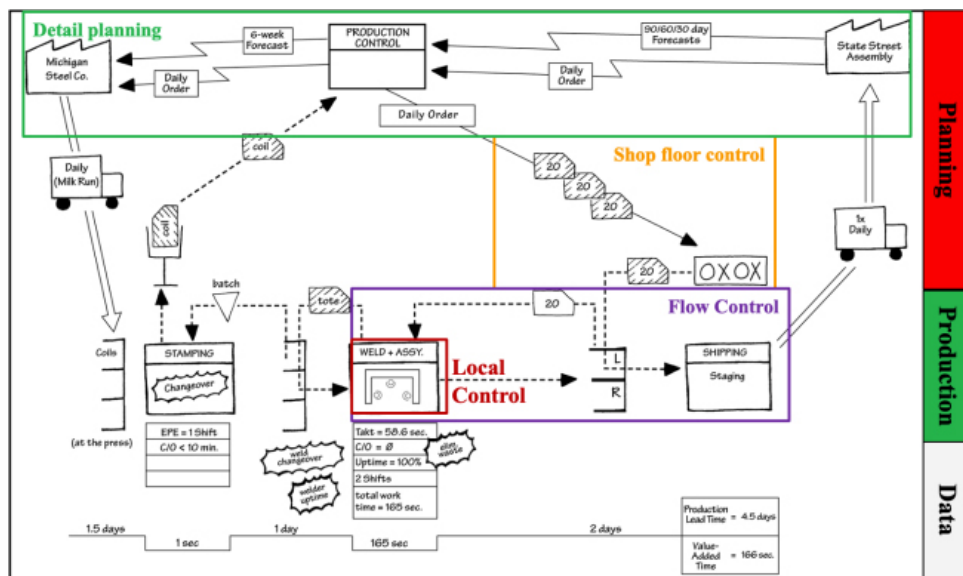

Fig. 1. PPC levels mapped unto a Value Stream Map

2. MRP + POLCA + local control, to control a MTO cellular shop floor
3. Kanban, to control standard components outside of MRP
4. ToC + local control, in a general job shop or general flow shop
5. Scheduling + local control, in a process oriented environment

Because of its dominance in practice, we will use an example around an MRP system to illustrate the new approach.

Extensions to the VSM method

We can now extend the VSM method to support the PPC configuration using this new framework. The changes are situated in two areas:

1. We need new symbols to document the PPC methods on the VSM map.
2. We need to extend and rephrase the original 8 design questions from Goldrath & Cox (2014) into 9 new ones.

The basic building block within VSM is the process, depicted by a rectangular symbol. There are 3 variants: generic process, production cell and shared resource (Lopez P. and Roubellat, 2008). Table 4 shows these and the 2 extensions (*) we introduced to the

Table 4
Extended set of process symbols

Work center type	Description	VSM symbol	Local control method
1 workstation	1 or more operations on 1 machine or manual workstation		Standard Work
Cell	Compact cluster of workstations with a fluid work organisation		Rabbit chase Bucket Brigade
Shared Resource	Large workcenter producing for multiple product families		Heijunka Time slicing policy
Line (*)	Linear layout of workstations with fixed operations and one piece flow organisation		Fixed cycle time
Job shop (*)	Collection of workstations processing orders with complex internal routings		Visual control by supervisor Local rules

set of process symbols. The Line form is an important special case, with its strict flow control. The Job Shop allows the deliberate choice of keeping a significant cluster of workstations unchanged, while still adding flow control (like CONWIP) to it. This is often a valid intermediate solution, when additional effort to identify cells is not possible or warranted. We also show some local control rules that can be used within the specific workstation form.

We also added symbols to document the PPC methods that need to be put on the VSM, shown in Table 5.

Table 5
Flow control VSM symbols

Flow control	VSM symbol	Parameters
Local rules		Rule logic (FIFO, SPC, EDD, ...)
CONWIP		Number of cards Work content of 1 card
POLCA		# of cells # of loops # of cards per loop
Theory of Constraints (ToC)		Bottleneck workcenter Capacity of buffers

We can now formulate the new set of 9 design questions that will guide the creative process to redesign the current state of the shop floor into one or more future states. We will not explain the steps that are close to the original VSM method, but instead focus on the redesign of the PULL methods to fit seamlessly with the flow control actions.

Going from the current state to a future state

Using the VSM as sketchpad, one can now reflect on the changes that will improve the overall flow and reduce lead time, leading to a better due date adherence. The data on the VSM should allow to judge the effects of the changes and the technical hurdles to overcome. The questions are discussed below, with the new ones set in bold.

1. What are the most important shortcomings in the current strategy?
To guide the direction of changes, it is important to clearly state the problems that need to be

solved: whether capacity is a problem, or due date adherence, or total lead time, or flexibility, ... This will reduce the likelihood of adopting PPC methods that are not appropriate.

2. What is the TAKT time for the product family under consideration?

This question is from the original set, focusing on the overall market demand rate that will dictate capacity and buffer sizes.

3. Where will the Decoupling Point (DP) be situated in the future state?

The DP is the inventory location from where customer orders are finalized (possibly customized) and delivered, determining the delivery time (Wikner & Johansson, 2015).

4. Which buffer stocks can I eliminate?

This is arguably the most important step in reducing lead time, aiming at combining process steps. The proposed addition of flow control and more process forms allows for more choices in achieving buffer reduction or elimination.

5. How do I organize the segments between the remaining buffers?

Basic VMS only use Kanban and FIFO as PULL methods to organize flow across the processes between two consecutive buffers. With our extended process forms we can now more carefully consider what is achievable.

6. Which methods of flow control will be used to couple the work centers in each segment, and across the buffers?

The choice will be determined by the configuration from questions 4 and 5, as well as by the ambition of the organization on how tightly the flow control should be. This can be as limited as to one cell and its feeding buffer, or as wide as to cover the whole shop floor, and its suppliers.

7. How should I adapt the legacy planning functions to the new shopfloor configuration?

This step has proven in practice to be a difficult one, in part because of the dominance of MRP at all levels (Stevenson et al., 2005), but often also because of lack of information and knowledge within the companies. We will explain this step in more detail below.

8. Determine the design parameters for the new control methods.

For each new process organization (cell, line) or flow control method one needs to determine the operating parameters. This often needs more detailed calculations or even simulations, considering fluctuations and trends in market demand, and future net capacity of the workstations, after lean improvements are factored in.

9. Which KPI's will be measured? What are the targets to achieve and by when?

Lean insists on measuring progress through objective KPI's to speed up learning and fostering experimentation along the path to improved flow. Without KPI's the planned evolution towards the future state is often stalled prematurely (Van Landeghem et al., 2018).

Adapting PUSH planning functions to the new shopfloor configuration

We illustrate the approach on an example, shown in Figure 2, featuring a traditional MRP push type of planning system, covering master planning to shop floor control. Within the MRP logic (Jacobs et al., 2018) the shopfloor is modelled by a Bill of Material (BOM, the tree of components in a product) and Routings (the individual production steps), shown for the example in Figure 3. The end product "FPB" is assembled from sub-assembly "101" and "102P" as component (P indicates a purchased item), and "101" in turn is assembled from "204" and "205", which are fabricated from "204P" and "205P".

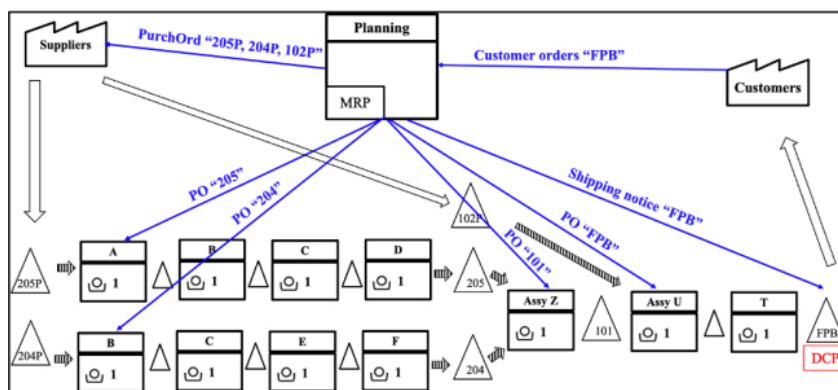

Fig. 2. Example Current state VSM with MRP PPC

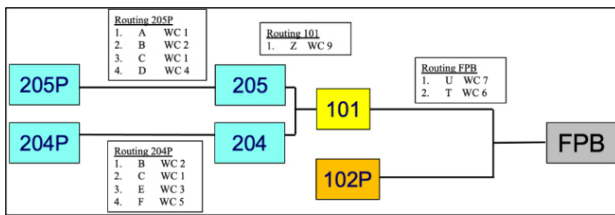

Fig. 3. Current state MRP configuration (BOM, Routings)

We now apply several changes (as result of applying the 9 questions) and describe the implications for the MRP system (“=>”), all of which are listed below. Figure 4 shows the future state VSM reflecting these changes, and Figure 5 shows the new MRP model, that fits with the PPC methods that were introduced (Kanban and cell).

1. We move the Decoupling point (containing FPB) upstream before any assembly operations, to replace the costly and difficult-to-forecast inventory of final products (Fig. 2) with less fluctuating inventories of components (Fig. 4).
=> no apparent changes result from this, except that the Master Plan will now contain item “204” instead of “FPB”. Items “205” and “102P” are removed from MRP control towards Kanban.
2. We combine assembly and finishing operations Z, U and T into one assembly line. This will increase productivity and reduce lead time, to counter the possible increase of delivery time by change 1. The work content will have to be balanced between the stations along the line.
=> part 101 is not a separate level anymore and is removed from the BOM, as is its routing record. Since the assembly will be executed in a production line organization, no separate tracking by MRP is needed, so the routing of “FPB” is also

eliminated.

3. Operations B, C, E, F to manufacture “204” out of “204P” are grouped together into one cell. This will reduce the lead time for this segment, as well as the control effort.
=> no big changes occur in the MRP, only the shortened lead time should be entered in the BOM for part “204”.
4. Operations A, B, C and D cannot be grouped in one cell. Instead we improve flow control by converting the inventory of “205” into a Kanban controlled supermarket. The Kanban replenishment loop extends to operation A (which makes it a so-called “long pull”), and the subsequent processes B, C and D are linked to A through FIFO lanes.
=> part “205” is effectively removed from MRP control, since the supermarket and Kanban loop will trigger production. So it is removed from the BOM, along with its corresponding routing.
5. After negotiations with the supplier, we set up a JIT link for purchase part “102P”, through a supermarket and a Kanban link with the supplier.
=> we can eliminate part “102P” from the BOM, since full control is now by Kanban. Future volume changes from the Master plan must still be communicated to the supplier.

The changes that were made to the MRP can easily be understood, if we realize that in the MRP logic each part in the BOM generates a production order, with a routing providing shop floor control. If we do not need this shop floor control because of added flow control from other PPC methods, we can remove the routing also. The changes will have to be accommodated within the model used in each PPC method involved. This can prove challenging when the model is all-encompassing (such as in Scheduling and ToC) or very specific (such as Kanban or FIFO).

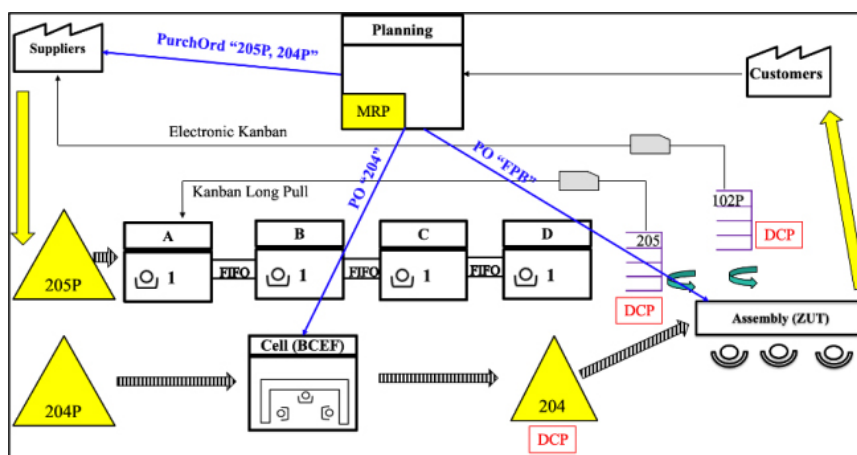

Fig. 4. Future state VSM of example

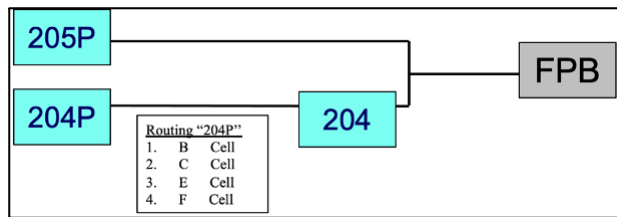

Fig. 5. BOM and routings of future state

Conclusions

This paper extends the VSM method to accommodate redesigning of the PPC architecture, to adapt it to changes in the material flow from continuous improvement. It has extended the PPC hierarchical model so the scope of PULL type PPC methods can be compared to the legacy PUSH methods. Finally, extensions to the VSM method are proposed, and illustrated with an example: new process symbols, new flow control symbols, and a new set of 9 redesign questions to support creation of future state VSM's.

The approach has been tested on several real-world examples and has proven to improve insight by the parties involved into this otherwise very opaque domain of production organization. Further research will try to identify the most common combinations of methods to cover the 5 levels, and the changes in each of them to allow a seamless collaboration. This will need considerable field research, since not much information is available in current literature, as already indicated by (Stevenson et al., 2005).

References

- Acero R., Torralba M., Pérez-Moya R., and Pozo A. (2020), Value Stream Analysis in Military Logistics: The Improvement in Order Processing Procedure, *Applied Science*, No. 106, Vol. 10. DOI: [10.3390/app10010106](https://doi.org/10.3390/app10010106).
- Annamalai S. (2020), Influencing parameters of productivity through value stream analysis using optimization techniques, *Materials Today: Proceedings*, Vol. 33, pp. 3591–3599.
- Bicheno J. and Hollweg M. (2016), *The Lean Toolbox*, 5th Ed., Buckingham: Picsie Books.
- Busert T. and Fay A. (2019), Extended Value Stream Method: Harmonizing Information Flows for the control of Production Processes, *IFAC Papers Online*, No. 13, Vol. 52, pp. 54–59.
- Gargalo C., Pereda E., Barbosa-Povoa A., and Carvalho A. (2021), *A Lean Approach to Developing Sustainable Supply Chains*, in *Sustainability*, No. 7, Vol. 13. DOI: [10.3390/su13073714](https://doi.org/10.3390/su13073714).
- Goldrath E. and Cox J. (2014), *The Goal*, Great Barrington: North River Press.
- Jacobs R., Berry W., Whybark D., and Vollman T. (2018), *Manufacturing Planning and Control for Supply Chain Management*, New York: McGrawHill Education.
- Karmarkar U. (1989), *Getting control of Just in Time*, in *Harvard Business Review*, Sept–Oct issue, 9, <https://hbr.org/1989/09/getting-control-of-just-in-time>.
- Lopez P. and Roubellat F. (2008), *Production Scheduling*, Hoboken: Wiley.
- Modig N. and Alhström P. (2012), *This is Lean – Resolving the Efficiency Paradox*, 2012, Stockholm: Rheological Publishing.
- Oberhausen C. and Plapper P. (2017), Cross-enterprise value stream assessment, *Journal of Advances in Management Research*, No. 2, Vol. 14, pp. 182–193. DOI: [10.1108/JAMR-05-2016-0038](https://doi.org/10.1108/JAMR-05-2016-0038).
- Ptak C. and Smith C. (2019), *Demand Driven MRP*, version 3, South Norwalk: Industrial Press.
- Rother M. and Shook J. (1999), *Learning to See*, Boston: Lean Enterprise Institute.
- Stadnicka D. and Litwin P. (2019), Value stream mapping and system dynamics integration for manufacturing line modelling and analysis, *International Journal of Production Economics*, Vol. 208. DOI: [10.1016/j.ijpe.2018.12.011](https://doi.org/10.1016/j.ijpe.2018.12.011).
- Stevenson M., Hendry L., and Kingsman B. (2005), *A review of production planning and control: the applicability of key concepts to the make-to-order industry*, in *Int. J. of Production Research*, No. 5, Vol. 43, pp. 869–898.
- Suri R. (2018), *The Practitioner's Guide to POLCA*, London: Routledge.
- Ulewicz R., Jelonek D., and Mazur M. (2016), Implementation of logic flow in planning and production control, *Management and Production Engineering Review*, No. 1, Vol. 7, pp. 89–94.
- Van Landeghem H., Claeys D., and Van Landeghem T. (2018), Sustainable Lean In SMEs: A Quantitative Analysis Into Improvement Actions, *Management and Production Engineering Review*, No. 4, Vol. 9, pp. 10–19.
- Wiendahl H. (1994), *Load Oriented Manufacturing Control*, Berlin: Springer.
- Wikner J. and Johansson E. (2015), Inventory classification based on decoupling points, *Production & Manufacturing Research*, 2015, No. 1, Vol. 3, pp. 218–235. DOI: [10.1080/21693277.2015.1067845](https://doi.org/10.1080/21693277.2015.1067845).