

Dorota WIĘCEK^{*}, Dariusz WIĘCEK^{**}

ESTIMATING PRIME COSTS OF PRODUCING MACHINE ELEMENTS AT THE STAGE OF PRODUCTION PROCESSES DESIGN

Abstract:

Using methods of planning automating of production processes as well as artificial intelligence, the methods presented in this paper were constructed for identifying the set value of manufacturing process parameters, which are key to evaluating the costs of the designed elements. The proposed solutions were adapted for systems used under the conditions of unit and small-batch production.

1 INTRODUCTION

Because of the development of market economy and growing competition, companies have to respond quickly and adequately to market needs, while ensuring at once high quality and low price of their products. In a rapidly changing business environment, it is necessary to identify and parameterize the processes within the company, which will allow for taking right decisions as to current production tasks. Considerable growth of competition has led to more attention being paid to the economic aspects of manufacturing, through reducing the costs of economic activities pursued and the overall costs of products that meet the required quality parameters. In a market economy, price is a function of the market as supply should match demand [1]. However, when setting the price of a product, its maker should take into account the costs incurred to produce it. Nowadays it is impossible for a manufacturer to start the process of designing and manufacturing a new product without careful estimation of its total production costs. In order to prevent too high expenses for launching the production of future products, their costs must be estimated as promptly and precisely as possible.

^{*} Eng. PhD. Dorota Więcek, Department of Production Engineering, Faculty of Mechanical Engineering and Computer Sciences, University of Bielsko-Biała, Willowa 2, 43-309 Bielsko-Biała, Tel.: +48 (33) 8279 253, E-mail: dwiecek@ath.bielsko.pl

^{**} Eng. PhD. Dariusz Więcek, Department of Production Engineering, Faculty of Mechanical Engineering and Computer Sciences, University of Bielsko-Biała, Willowa 2, 43-309 Bielsko-Biała, Tel.: +48 (33) 8279 253, E-mail: wiecekd@ath.bielsko.pl

2 THE PROPOSED METHOD OF ESTIMATION OF COST OF MACHINE ELEMENTS ON THE STAGE OF PRODUCTION PREPARATION

The proposed method of cost estimation for machine elements belongs to the methods of cost calculation. It bases on a formalized description of information with constructional, manufacture and organizational features related to a designed element, the method of design automation of technological process design (variant design, generation design), which uses the methods of group technology, artificial intelligence (pattern recognition, expert systems), and the model of production cost estimation for machine elements based on Activity Based Costing [7, 6]. These assumptions locate the proposed method among hybrid group (linking the above mentioned methods) of cost calculation methods.

The course of action in the proposed method was divided into several phases, which use information generated on different stages of production process design aided by the CAx systems or information stored in databases of these systems [6]. The assumed model of procedure and location of subsequent phases in functional areas of the CAx systems was presented on figure 1.

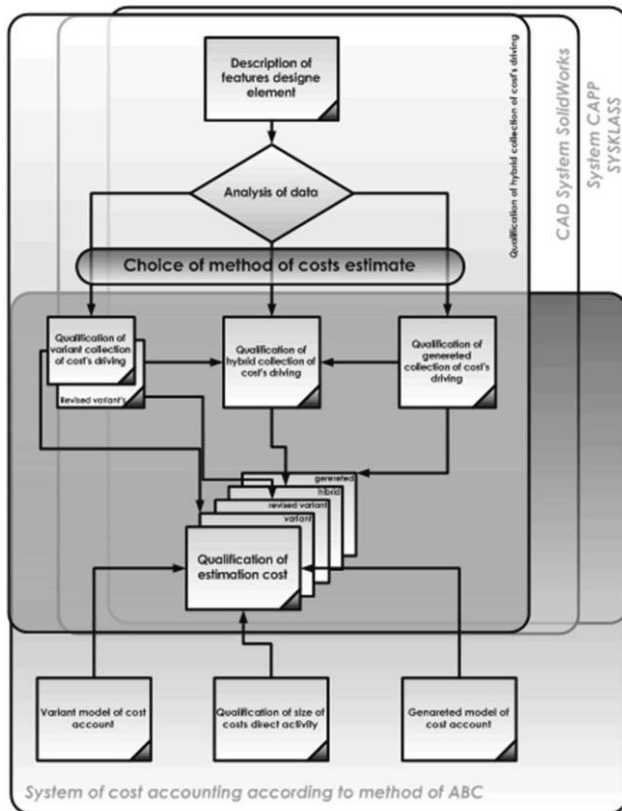

Fig. 1: General model of procedure in the proposed method
source: self-elaboration

3 THE METHOD OF ACTIVITY BASED COSTING

The implementation of the method of Activity Based Costing is not easy in practice. The method is connected with processes and, within these processes, with separated activities, and not with subjects (departments, divisions), where the processes and activities are carried out, so it is not adapted to traditional production organization. Processes do not finish on the border of organizational units, but they spread into functional ranges. Implementing calculation based on activity analysis brings about not only the change of calculation procedure itself, but the change of an organization, enterprise, reorganization of the way of cost measurement and record. This method, unlike the traditional cost account, seems to be easier to understand by workers, who have no contact with accounting [8].

On the basis of production practice, a method of activity cost estimation was worked out (Activity Calculation Sheet – ACS) and activity cost calculation was prepared on cost objects. The starting point for preparing activity cost account is creating a database of all activities performed in an enterprise. This can be made by means of the ISO system procedures, technological documentation (technological cards, machining manuals), documents on the course of production (production orders, work cards), interviews with directors and workers of an enterprise. Apart from activity identification, it is also necessary to describe them, that is: to determine by which departments the operations are carried out, how many people perform actions which compose the given activity, what is their work time, what meaning the separated activities have for the enterprise, what data express effects of activities. The specified direct, indirect activities and connections between them create the so called map of direct and indirect activities presented on fig. 2.

For activities a description of actions in the range of each activity was collected together with the place of appearance of these actions (cost position) and the accepted size measures of throughput for the activities. By choosing the size measures of activity throughput, it is necessary to pay attention to the source of acquiring these data, which should constitute a compromise between measurement accuracy and its cost. The best solution in this situation is acquiring data from the existing documentation.

4 ACTIVITY CALCULATION SHEET

In ACS, indirect generic costs were calculated as first. Their value is gained from a 4 factory group account plan, no cost position in a direct way on the basis of source evidence, or in an indirect way, according to fixed calculation keys. Next, these costs are calculated on actions of particular activities performed within the given workplace. In the calculation, a part of the costs is directly ascribed to an action on the basis of source document (e.g. costs of using indirect materials on the basis of documents of taking material out of store), and the rest is calculated on the basis of the share of workers' time connected with realization of the actions within the given cost position. In this situation it is necessary to register the time by workers for particular cost positions.

It is required that the registration is carried out automatically by means of a computer system, which would calculate the time devoted by a given worker for realizing a given action. Also, singular (at the end of month – basing on a report) record of the time is advantageous here. The prepared reports make it possible to calculate workplace costs, which are impossible to calculate directly, on particular actions being within a given workplace. A sample report from a cost position related to one worker is presented on fig.3.

After calculating all indirect generic costs, they were summed up and we obtained a total cost of the given action, total activity cost and total cost of the cost position. The next step is to calculate inter-factory services, that is: cost of indirect activities on the remaining activities according to services provided for these activities. In order to calculate the cost of indirect activities, first it is necessary to determine the structure- the sequence of calculation, which is presented on fig.4.

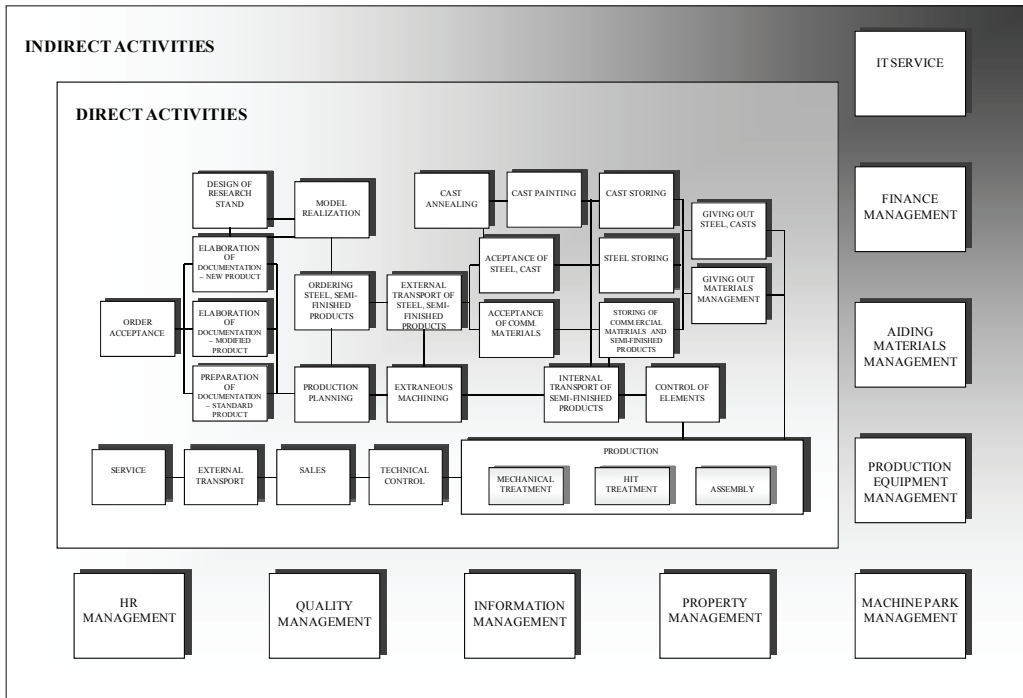

Fig. 2: Map of direct and indirect operations
source: self-elaboration

According to this order, the cost of indirect activities was calculated on the remaining activities, taking into consideration mutual service provision, on each grade. After calculating the cost of indirect activities from the first to the fourth grade, total cost of indirect activities in a given period was obtained, for which an ACS was prepared. The total cost of direct activities in a period, with itemizing of indirect activities cost and generic cost ascribed to the activities, is presented on table 1.

stanowiska_kosztowe

id 16 nazwa Dział Zaopatrzenia grupa Gospodarki materiałowej

Koszty bezpośrednie działań Raport miesięczny

pracownicy_stanowiska

id 46 pracownik DZ1

id raportu 149 data 2008-02-28

działanie	ilość wystąp.	Ogólny czas dział.
4 Gospodarka Materiałami Pośrednimi	15 razy	504,00 min
20 Zamówienie odlewów	5 razy	3 024,00 min
26 Zamówienie stali	8 razy	3 528,00 min
28 Przyjęcie stali	7 razy	1 512,00 min
31 Zamówienia handlowe	10 razy	907,00 min
33 Przyjęcie materiałów handlowych	10 razy	605,00 min
72 Przyjęcie odlewów	7 razy	854,00 min

Rekord: 16 z 29

Fig. 3: A sample report from a supply department
source: self-elaboration

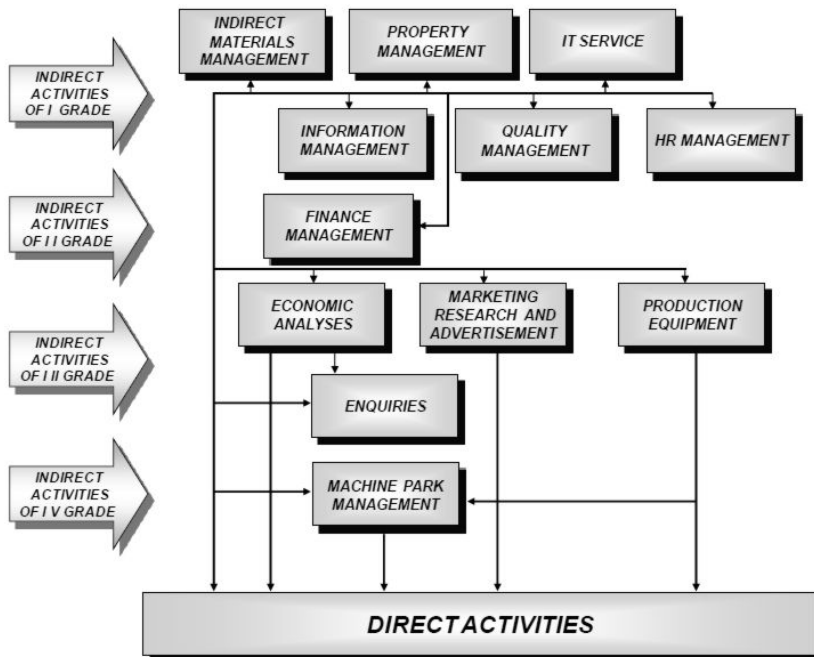

Fig. 4: Structure of indirect operations
source: self-elaboration

In order to prepare product calculation, the cost of product unit of direct activity was calculated by dividing the total cost of direct activities, gained from Activity Calculation Sheet, by measures of throughput size of these activities. Sample measures of throughput size for the chosen activities were presented on table 2.

*Tab.1: Total cost of direct operations
source: self-elaboration*

	Operation	Generic cost of activities	Cost of indirect activities	Total activity cost
1.	Order acceptance	14 600,93 zł	35 743,59 zł	50 344,53 zł
2.	Preparation of documentation – standard product	3 416,04 zł	960,76 zł	4 376,80 zł
3.	Elaboration of documentation – modified product	5 607,96 zł	1 587,39 zł	7 195,34 zł
4.	Elaboration of documentation – new product	10 318,59 zł	2 828,41 zł	13 147,01 zł
5.	A design of research stand/station	1 429,81 zł	1 180,17 zł	2 609,98 zł
6.	Production planning	5 975,55 zł	1 681,84 zł	7 657,39 zł
7.	Model realization	883,85 zł	1 044,61 zł	1 928,46 zł
8.	Ordering casts	1 790,16 zł	505,08 zł	2 295,24 zł
9.	Cast storage	2 626,45 zł	4 749,78 zł	7 376,23 zł

*Tab.2: Sample size measures of activities
source: self-elaboration*

Activity	Activity size measure
Production planning	Number of production batches Number of workshop guides Number of production orders
Machine park management	Number of conservation and repairs Number of machine – hours Number of controls
Ordering materials	Number of orders Number of supplies Number of received invoices
Control of elements	Number of man – hours Number of controlled elements

5 A MODEL OF ESTIMATION OF MACHINE ELEMENTS' PRODUCTION COST

Production cost of a product covers the ensemble of activity cost, as a consequence of which a finished product of a given value is created from raw material or materials. The complexity of manufacturing is determined by the level of difficulty and constructional and manufacture connections taking place between different levels of a product (sets, subsets, elements) [2].

Values of parameters related to manufacturing processes designed by means of the variant method or generation method do not relate strictly to the variables influencing the value of particular components of production cost. Hence, it is necessary to determine a set of cost's

driving factors: that is factors which equivocally determine the value of variables related to the separated cost components and the way of their determination.

A basic task to be done is to determine the value of cost driving factors on the basis of the description of a designer element using the COPE sets and values of parameters describing particular COPE. This task may be realized in three ways, by means of the variant, generation or hybrid approach.

In further elaboration the hybrid method of estimation of cost's driving factors will be discussed.

5.1 The hybrid method of creating sets of values for cost's driving factors

If the COPE set for a designed element after the design decision δ was not completely settled, it is impossible to apply only generation approach to creating a set of cost driving factors, because settled estimation costs on the basis of such set of values would be far different from real cost. Such situation would be caused by impossibility of generating by the expert system a set of sub-activities of transformation process for COPE of equivocally described, (the one for which not all parameter values of these COPE have settled values or there is no determine tolerance of these values). Appearance of such cases creates the basis for proposing a hybrid approach to creating sets of values of cast driving factors.

A scheme of procedure in the presented approach is shown on figure 5. In case of hybrid approach, the system generates separately sets of sub-activities for the designer and variant element. In this approach these sets undergo analysis in order to separate hybrid sets of treatments (sub-activities) of the transformation process.

5.2 Generating a set of sub-activities for the transformation process-technological operation

The presented method relates to generating a set of parameters of a manufacturing process connected with features which describe the designed element (COPE). Particularly the module, on the basis of the COPE set and values of parameters describing the designed element, generate a set of values for production process parameters. The values are connected to sub-activities, which are here understood as technological treatments needed for a given feature to obtain qualities complying with constructional assumptions. The functioning outline of this module is shown on figure 6. On the basis of PN-83-/M-01250 a treatment is a part of operation related to machining its surface with one tool and fixed machining parameters. The basic tool here is a dedicated expert system. According to the assumptions of expert systems' structure, a database of the analysed objects was established in the proposed system in the form of:

- **COPE sets - FP_{δ}^{ep}** ;
- Sets of values for parameters describing **COPE - VPT^{ep}** .

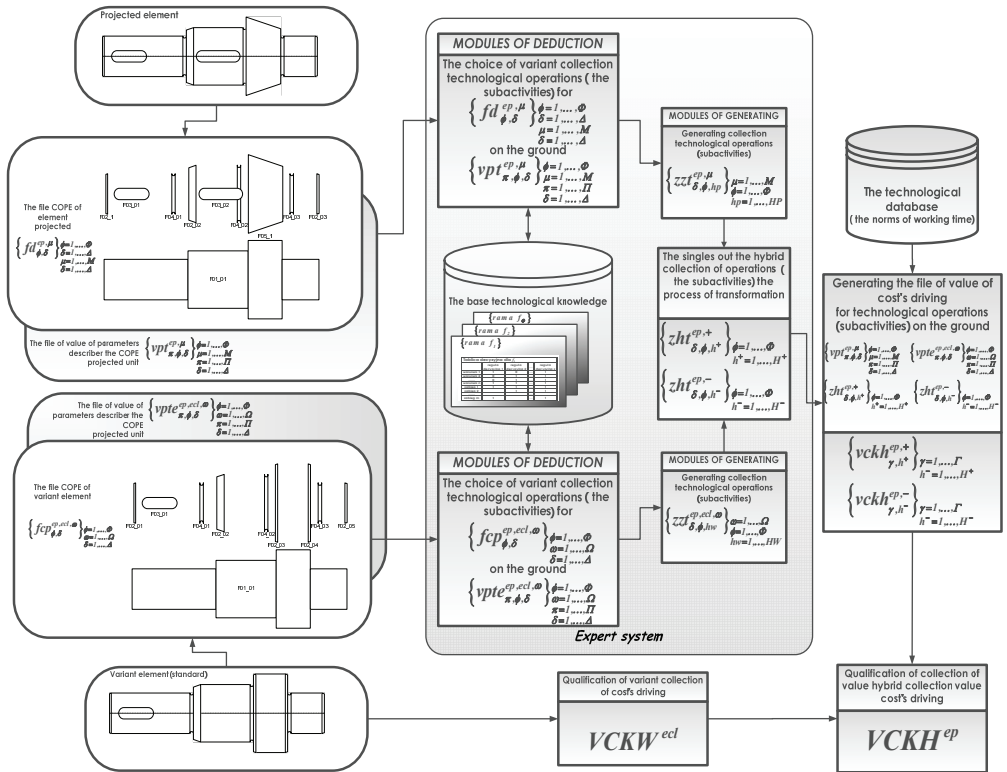

Fig. 5: Qualification of hybrid collection of cost's driving source: self-elaboration

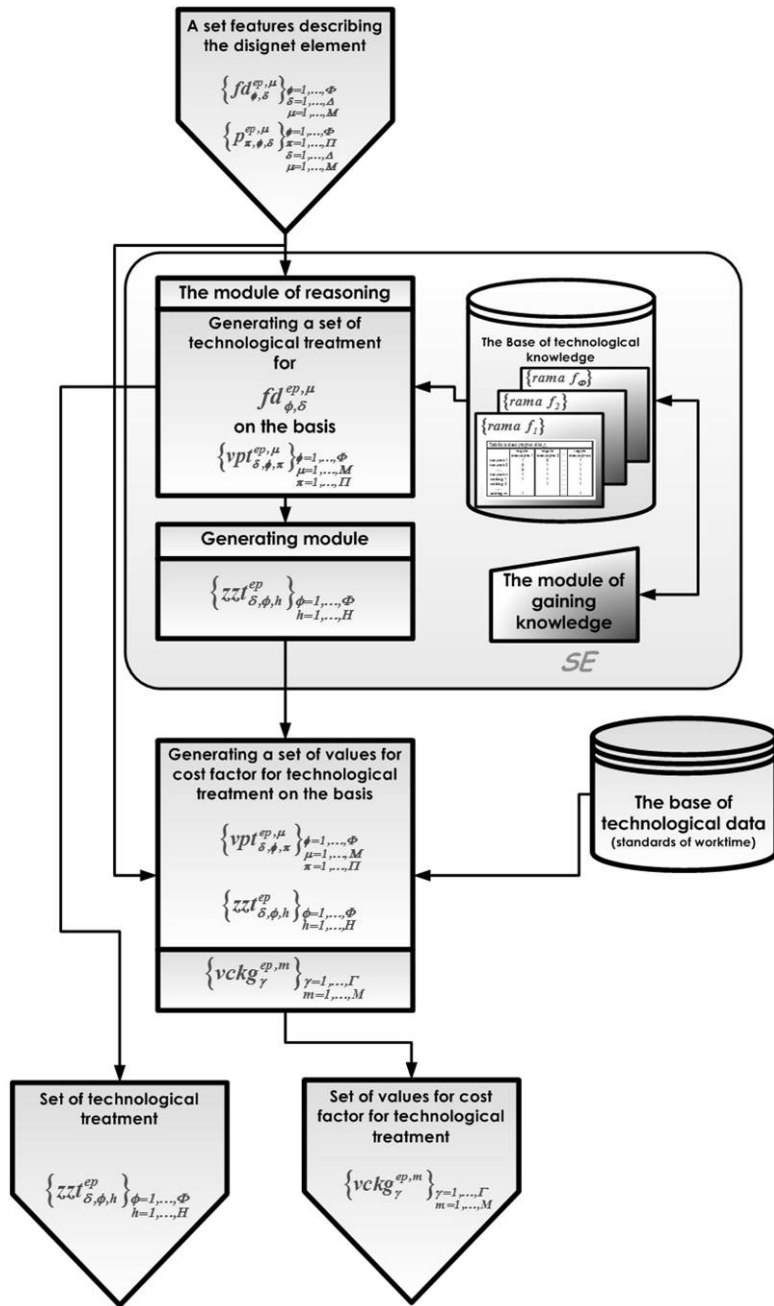

Fig. 6: An outline of generating parameter values for a manufacturing process for particular COPE source: self-elaboration

The proposed base of technological knowledge stores basic technological knowledge which was gained from an expert. The knowledge gathered in the base has to enable for determining the values of manufacturing process parameters, so it relates information about sets of technological treatments for a given feature, required to achieve the assumed values of usable parameters in the accepted variant of a manufacturing process, and for each treatment- information about production workplace, as well as grouping workers adequately for the given technological treatment.

A very significant stage of database design is determining the way of knowledge representation. On the basis of the conducted analyses, knowledge representation was accepted in form of frames and rules. Representation of technological knowledge in form of frames was dictated by plurality and diversity of the gathered information for particular COPE.

Hence, the knowledge divisions into frames for particular COPE $\{rama f_{\phi}\}$.

Each frame is linked to a set of rules $\{reg f^r_{\phi}\}$, on the basis of which a set of activities is determined. The activities enable to achieve parameter values assumed for certain features with fixed parameter values describing the remaining COPEs for a given element, including which variant of a manufacturing process it is dedicated for. Decision tables were used for knowledge representation due to the fact that knowledge record within decision frame is based on reasoning rules, and a conclusion of a given rule related to choosing a set of technological treatments together with attributed production workplaces and groups of workers is of activity type.

In the knowledge base proposed in the paper, premises are created on the basis of COPE parameter values and value tolerance of these parameters. Each premise is a logical sentence, which is a conjunction of phrases checking if parameter value is included in the assumed interval and if tolerance of a given value is included in the estimated interval. Logical value of a premise assumes a logical result of a task determined for it, or its negation, according to the rule where the premise is considered. Logical value of a premise may assume the following values:

- *1 - if truthfulness of a premise is significant in the given rule;*
- *0 - if falseness of a premise is significant in the given rule;*
- *„-“ - if a premise is insignificant in the given rule.*

Each rule in the proposed knowledge base is connected with a set of technological treatments necessary to achieve the required constructional parameters of a considered feature. Thus, we can say that each rule is a variant of a manufacturing process.

The value of activities – stating if a given activity (technological treatment) should be carried out, if a given rule is fulfilled, takes values connected to the order of appearance of a given treatment in a process variant (rule) or NULL value if a given treatment is not present in the variant.

Acceptance of a given variant (that is fulfilling the given rule) takes place if all significant premises for this rule took the value determined in the part of decision table which includes values of premises. Table 3 presents a fragment of sample decision table for the frame connected to COPE F76_k01 (simple through-holes).

Apart from previously discussed elements, in a table with the following construction also the elements which support the creation of logical conditions forming premises were separated. The presented table includes information on parameters (column: param), whose values are considered in logical conditions, as well as information on interval boundaries of values taken by these parameters together with their tolerance (columns: od_val, do_val, od_IT, do_IT).

The proposed way of knowledge representation required building a module of gaining the needed knowledge for the accepted way of its interpretation.

The structure of the module of knowledge acquisition is closely connected with the adopted method of its acquisition. The paper proposes a direct method of knowledge acquisition called 'learning by heart'. The designed module of knowledge acquisition is a dialogue interface, through which an expert records his knowledge about creating such sets of technological treatment (variants of manufacturing) w the given factory conditions and according to parameter values adopted through COPE which describe the elements of a given type of production.

Tab. 3: Decision table for a frame {frame F76_k01}- simple through-holes(fragment)
source: self elaboration

{frame F76_k01}-simple through-holes								
	parameter description	od_val	do_val	od_IT	do_IT	war1	war2	war3
p1	Simple through-holes int. diameter. D.	0	26	20	12			1
p2	Simple through-holes int. diameter. D.	26,01	40	20	12	1		
p3	Simple through-holes int. diameter. D.	41	500	20	12		1	
p4	Simple through-holes length L	0	60	20	12	1	1	1
p5	Simple through-holes roughness	0,64	12,5	0	0	1	1	1
p6	Round bars type	0	4	0	0	1	1	1
d1	treatment: turning reaming roughly / workplace: 0440102 /worker: turner					3		2
d2	treatment: turning drill-rebor / workplace: 0440102 / worker: turner					2	2	
d3	treatment: turning drill with machine with feed / workplace: 0440102 / worker: turner					1	1	1
d4	treatment: shaping coarse. Ra3.2 / workplace: 0440102 / worker: turner						4	
d5	treatment: turn roughly longitudinally / workplace: 0440102 / worker: turner						3	

Interpretation of record in such a table for shadowed elements may take a form of a logical sentence:

If: [(parameter value pF76_k01_00 belongs to the interval <41, 500>) and (parameter value tolerance pF76_k01_00 belongs to the interval <20, 12>)]
and [(parameter value pF76_k01_01 belongs to the interval <0, 60>) and (parameter value tolerance pF76_k01_01 belongs to the interval <20, 12>)]
and [(parameter value pF76_k01_02 belongs to the interval <0,64, 12,5>)]
and [(parameter value pF20_k01_00 belongs to the interval <0, 4>)]

Perform the treatment of :

reboring on workplace 0440102 by a turner as- 2
and drilling on workplace 0440102 by a turner as- 1
and shaping turning on workplace 0440102 by a turner as - 4
and rough turning on workplace 0440102 by a turner as- 3

A variant of the manufacturing process should allow for achieving constructional parameters assumed in the course of construction design process. The module of knowledge acquisition was designed in such a way that an expert could use information about all parameters describing the considered feature and about parameters describing the remaining features which create the description of elements of a given type. Figure 7 presents a form, by which an expert enters data related to a given variant of machining that is a determined set of treatment for the given COPE, which is a set of sub-activities present in the decision table for this feature – simple through-holes.

Figure 8 presents a form, by which premises are determined, used in the decision process when choosing the variant of machining for the feature- simple through-holes

Fig. 7: Form of entering technological treatments which create the variant of manufacturing process for COPE – simple through-holes
source: self-elaboration

id	id_param	odval	doval	odIT	doIT
31	otwory przelotowe proste ŚREDNICA WEW. D.	26,01	40,00	20	12
32	otwory przelotowe proste CHROPOWATOŚĆ	0,64	12,50	0	0
33	otwory przelotowe proste DŁUGOŚĆ L	0,00	60,00	0	0
42	pręty okrągłe TYP	0,00	10,00	0	0
*	(nie)	0,00	0,00	0	0

Fig. 8: Form of entering the premises
source: self-elaboration

On the basis of sets of information gathered in this way, decision tables are created, which are used in the reasoning process that is the process of choosing the variant of treatment sets for the given feature.

The proposed expert system adopted a method of ‘ahead’ reasoning (progressive). This method assumes that on the basis of known rules, premises and facts, the system generates new facts, for which there is a fact in the knowledge base, which is an answer for the aim (hypothesis), or there is no possibility of finding solution on the basis of known generated facts [5, 4].

In the considered aspect, the aim is to check if the given variant of a technological process may be applied for the determined COPE.

Because there are different numbers of premises, a specificity strategy of reasoning steering was used. The specificity strategy assumes that rules are checked according to the number of premises in the given rule, starting from the highest number. With the same number of premises the rule is chosen, which contains the smaller number of variables [3, 4].

6 EXAMPLE

In order to illustrate possibilities of change analysis of self cost of the designer element in the course of the construction record process for the element presented on figure 9, an analysis of estimating cost change of this element was carried out during subsequent changes in creating construction record.

The first stage of realization of manufacturing self cost estimation on the stage of design for a sample element is determination of variants of constructional representation creation. A set of settled variants is presented on figure 10.

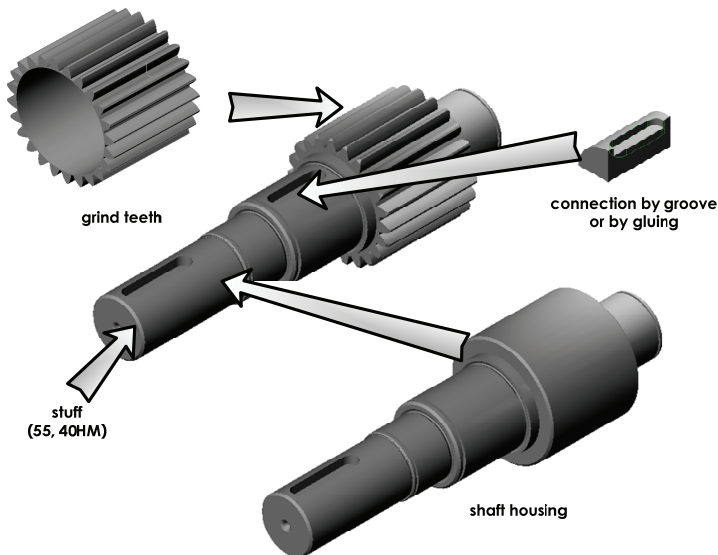

*Fig. 9: Features of a sample designed element
source: self-elaboration*

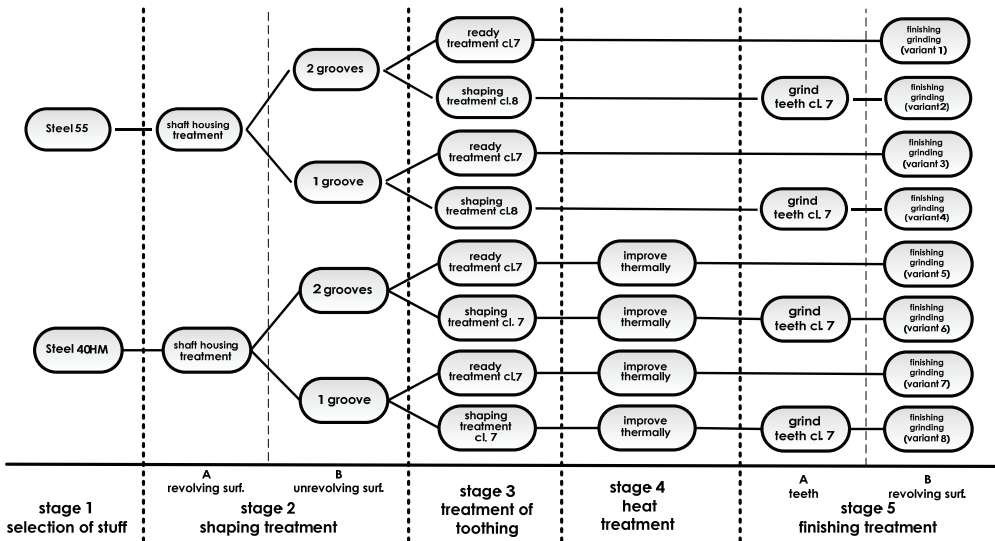

Fig. 10: A set of variants and manufacture phases of a constructional representation of a sample element.
source: self-elaboration

Final estimating cost of particular variants of manufacture of different constructional representations of the ample element was presented on figure 11.

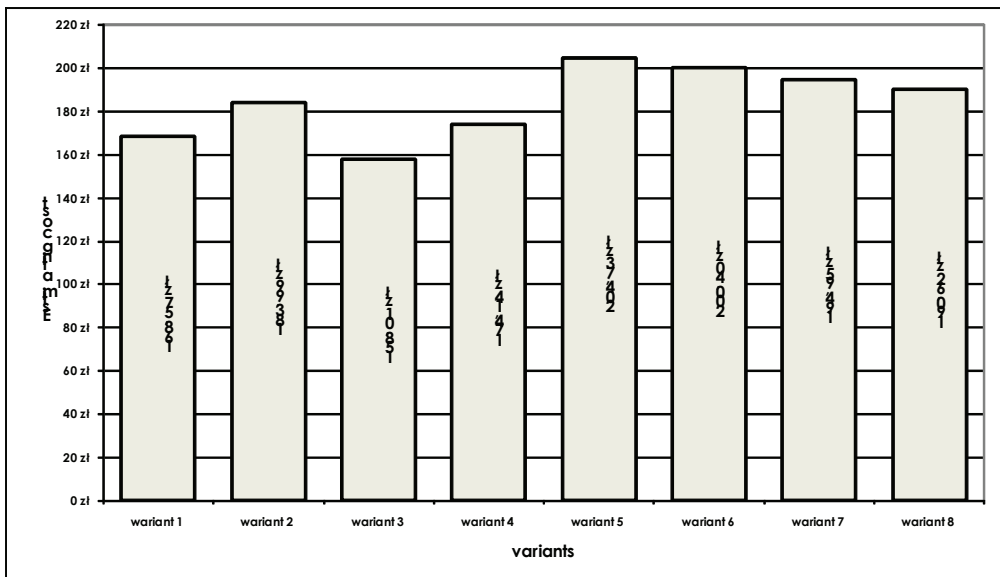

Fig. 11. A set of estimating self costs of manufacture for all variants of element production
source: self-elaboration

7 AUTHOR'S CONCLUSIONS

On the basis of the conducted research, the following conclusions of a cognitive character were drawn:

- The use of construction basing on parametric constructional features accelerates the process of creating the writes of construction, but it also permits automatically to execute in figures the file of features describing the writes of information on the projected units as well as the files of value of parameters describing the features of elements required on further design stages.
- The Activity Based Costing delivers the particulars about real costs of products, realized processes and connected activities which constitute the basis for decision-making in the production process management.
- The correct determination of costs of the projected elements is dependent on the assumed model of cost account. The settlement of cost variables as function of the parameter values of the features describing the projected elements permits on automatic costs determination on the ground of the description of the projected element.
- The methods of pattern recognition on the ground of the collection of constructional, manufacturing and organizational features describing the projected elements lets us find such element whose process of manufacturing contains the required activity for the realization of the established construction.
- Having at our disposal the collection of parameter values of features, we can, using the expert system, generate the collection of activities and sub-activities of manufacturing process, necessary to obtain the assumed parameters of the projected element, as well as required from the point of view of the manufacturing of a given element.
- The parametric description of the projected element lets us establish, on the base of the proposed methods, the influence of changes of values of particular parameters at the own expense of this element.

Conclusions of utilitarian character were introduced as follows:

- Application of the description basing on functional features of the projected elements permits on automatic identification of the newly projected elements, as well as for the division of the already existing elements into groups on the ground of any number of particular and organic constructional, production and organizational data.
- The proposed cost accounting model basing on very detailed analysis of cost factors whose values are defined on the ground of the of parameter values of features describing the elements, allows for the possibility of on-spot analysis of the influence change values these parameters at the expense of the projected element. The designer in the course of creating writes of construction of the projected element can conduct such analysis.
- The presented connection of the CAx systems with cost systems and further with book-keepers systems allows for the possibility of analysis of costs change of the projected elements regarding the changes in the financial structure of the enterprise, as well as the changes at organization of the manufacturing process.

In the range of notes and conclusions as to further research, the following postulates were proposed:

- It is necessary to extend the proposed methods by cost-analysis of the activities connected with assembly, which would permit for estimation of the costs not only machine elements, but also the costs of subassemblies, assemblies and whole fabrications.

- In further studies attention should be drawn to the adaptation of the introduced solutions to cost-analysis on the ground of the information gained in phase of marketing preparation of production as well as conceptional project.
- The ISO STEP standard is a world-widely developed standard. Further development of the proposed method of the projected element description should therefore concern its adaptations to the standard.
- The use of the proposed methods in connection with internet techniques would permit the transactors to design not only using typical elements, produced in a particular enterprise, but using typical features creator atypical elements and simultaneously would gain information about the price of the projected order.

References

- [1] BRINKE E.: *Costing support and cost control in manufacturing*. PhD. Thesis, University of Twente, Enschede 2002.
- [2] BRZEZIŃSKI M.: *Organizacja i sterowanie produkcją*. Agencja Wydawnicza Placet, Warszawa 2002.
- [3] CHANG T.C.: *Expert Process Planning for Manufacturing*. Addison-Wesley Publishing Company, Inc., New York 1990.
- [4] CHEN Y.M., WEI C.L.: *Computer -aided Feature – based Design for Net Shape Manufacturing*. Computer Integrated Manufacturing Systems Vol. 10, No. 2 Elsevier Science Ltd., s. 147-164. 1997.
- [5] IGNIZIO J.P.: *An Introduction to Expert Systems*. McGraw-Hill, New York 1991.
- [6] KNOSALA R.: *Zastosowania metod sztucznej inteligencji w inżynierii produkcji*. WNT, Warszawa 2002.
- [7] LOGAR B., PEKLENIK J.: *Feature-Based Part Database Design and Automatic Forming of Part Families for GT*. Annals of the CIRP, Vol. 40/1/1991, s. 153-156, 1991.
- [8] MILLER J., PNIEWSKI K., POLAKOWSKI M.: *Zarządzanie kosztami działań*. Wydawnictwo WIG - Press, Warszawa 2000.