

Darius EIDUKYNAS
Vytautas JÜRĖNAS
Egidijus DRAGAŠIUS
Arkadiusz MYSTKOWSKI

A BURST TYPE SIGNAL GENERATOR FOR ULTRASONIC MOTOR CONTROL

ZASTOSOWANIE PIEZOGENERATORA DRGAŃ ELEKTRYCZNYCH DO STEROWANIA RUCHEM SILNIKA ULTRASONICZNEGO

The aim of this study was to investigate a novel burst type signal generator for controlling an ultrasonic motor (USM). For this purpose, an experimental burst type signal generator consisting of a shock exciter, a waveguide, a Langevin-type piezoelectric transducer and backing mass was designed and investigated. The proposed burst type signal generator allows to control a USM in stepper motion, rendering traditional signal generators and power supplies superfluous. The investigated burst type signal generator is designed for controlling a USM with a 20.2 kHz resonant frequency and allows to generate a burst type electric signal with the same frequency. In view of the fact that such a harvester does not require traditional power supply, it could be used as an impact energy harvester. Also, a simple scheme for improving shock exciter operation using an additional capacitor was proposed and investigated. Such a scheme allows to drive USM up to 30 steps instead of 1 per one electric charge of the additional capacitor.

Keywords: *Ultrasonic motor control, micro-positioning system, burst type signal generator, shock generation, energy harvesting, ultrasonic motor control, increase of reliability.*

Niniejszy artykuł przedstawia badania nowatorskiego układu sterowania przemieszczeniem kątowym silnika ultrasonicznego za pomocą piezogeneratora drgań elektrycznych. W tym celu, został zaprojektowany oraz zbudowany piezogenerator drgań elektrycznych, który składa się z generatora drgań mechanicznych, przetwornika piezoelektrycznego typu Langevina i masy rezonansowej. Zastosowany piezogenerator drgań elektrycznych pozwala generować sygnały elektryczne o częstotliwości 20,2 kHz i tym samym umożliwia precyzyjne sterowanie krokowym piezosilnikiem ultrasonicznym. Dodatkowo, piezogenerator drgań elektrycznych pozwala na odzyskanie części energii drgań i przekształcenie energii mechanicznej na elektryczną, co z kolei umożliwia wyeliminowanie dodatkowych źródeł zasilania zewnętrznego. W pracy zrealizowano również drugi układ sterowania z zastosowaniem kondensatora włączonego w układ piezogeneratora sygnałów elektrycznych. Pozwoliło to na wydłużenie ilości generowanych krokowych przemieszczeń piezosilnika z 1 do 30 dla jednorazowego ładowania kondensatora piezogeneratora.

Słowa kluczowe: *układ sterowania ruchem silnika ultrasonicznego, układ mikro-pozycjonowania, piezogenerator drgań elektrycznych, generator drgań mechanicznych, układ odzyskiwania energii, piezoelektryczny silnik ultrasoniczny, zwiększenie niezawodności działania.*

1. Introduction

Usage of USM in ultra-precision devices has been gradually increasing in various technical fields such as robot joints, high precision devices, micro robots, automated focusing systems of cameras and MEMS [3, 9]. There are two basic types of piezoelectric motors: the rotary motor [3, 9, 10] and the linear motor [5, 6, 11]. Piezoelectric motors have many advantages over conventional electromagnetic motors, including a high torque at low speed, a large holding force without a power supply, silent operation, simple structure, high precision positioning, fast response and no electromagnetic noise generation [11]. Piezoelectric motors produce linear or rotary motions by their resonant vibrations excited via inverse piezoelectric effect of the PZT elements [10]. Due to this fact piezoelectric motors excitation signal frequency must correspond resonant frequency of the motor vibrator (stator), which generates a standing or travelling wave [4]. In order to obtain constant rotational or linear movement of piezoelectric motor, excitation signal should be harmonic, and in order to obtain step motion, excitation signal should be burst type [7]. In fact that the driving speed of the motor depends on both the amplitude and frequency of the excitation signal, the maximum speed or step size is obtained when burst type excitation signal frequency corresponds frequency of resonant vibrations of the piezoelectric motor stator [2, 7].

Most of piezoelectric motors used for various purposes are excited with signal, generated by signal generators [2, 4, 5, 6, 7, 10, 11], which requires some kind of traditional power supply. In order to use ultrasonic motors in areas, where traditional power supplies or electricity is unavailable, a new type of piezoelectric motor control technique is needed.

In this paper a novel burst type signal generator for ultrasonic motor control is designed, built and investigated. Presented burst type signal generator can operate as alternative method for ultrasonic motor control when traditional methods, such as signal generators are unavailable or damaged. This decreases risk of ultrasonic motor exploitation failure when traditional systems are damaged or are unavailable in areas such as nature, space, etc. In order that presented burst type signal generator can drive both rotational and linear USM, such a control method allows to increase reliability of precision positioning drive exploitation.

2. Structure and operating principle

A burst type signal generator for driving USM is presented in Fig. 1. Such a generator consists of some kind of alternative energy supply 1 (e.g. thermoelectric, solar cells, human's muscle force, etc.), shock exciter 2 (e.g. hummer-type impactor, piezoelectric shock gen-

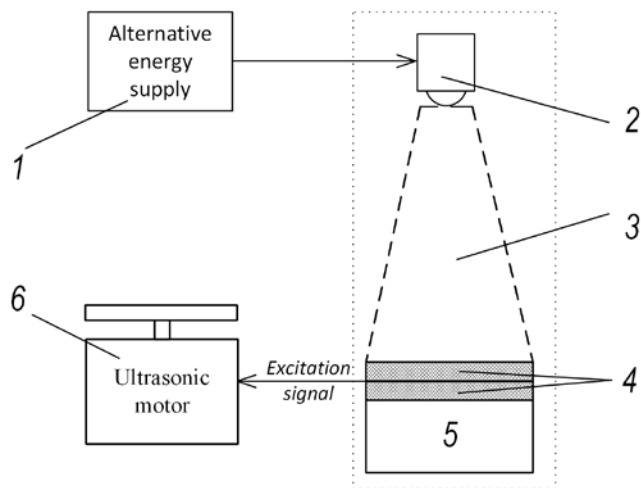

Fig. 1. A scheme of USM control using burst type signal generator: 1 – alternative energy supply, 2 – shock exciter, 3 – waveguide, 4 – Langevin-type piezoelectric transducer, 5 – backing mass, 6 – rotary USM

erator, etc.), horn type waveguide 3, Langevin-type [1] piezoelectric transducer 4, made of piezoelectric rings, backing mass 5 and USM 6, which should be controlled. It should be noted that waveguide, Langevin-type piezoelectric transducer and backing mass should be designed for certain frequency.

In presented burst type signal generator the energy is generated by mechanical shock on waveguide’s surface with smaller cross sectional area and is transmitted to surface with greater cross sectional area of the waveguide, thus energy from excitation shock is dispersed and displacement of surface (with greater cross sectional area) is obtained. This surface transmits displacement and energy with entire surface area to Langevin-type piezoelectric transducer. Surface area corresponds Langevin-type piezoelectric transducer diameter so due to this fact the piezo electric transducers can generate electric signal for USM control with the highest amplitude and certain frequency.

By altering waveguide shape and mechanical shock parameters, such as shock amplitude and duration, excitation signal with required frequency and amplitude for certain USM control could be obtained.

3. Design of burst type signal generator for USM-50-2 control

In fact that ultrasonic motor, in our case – USM-50-2, has 20.2 kHz resonant frequency (more technical characteristics of motor are presented in table 1), a burst type

Table 1. Parameters of ultrasonic motor USM-50-2

Characteristic	Measurement unit	Value
Motor type	-	Piezoelectric, rotational
Motor resonant frequency	kHz	20.2
Rated RMS voltage	V	21.28
Rated torque	Nm	0.004608
Rated rotational speed	rpm	56.075
No-load maximum rotational speed	rpm	78.947
Maximum torque	Nm	0.006912
Resonance quality factor	-	300
Capacitance per phase	nF	13

signal generator with longitudinal resonant frequency of 19.8 kHz, with stepped-exponential shape waveguide and shock exciter was designed and fabricated.

Designed burst type signal generator 3D model view is presented in Fig. 2 and impedance, obtained with Impedance meter Wayne Kerr 6500B, is presented in Fig. 3.

The stepped-exponential shape (Fig. 2) was chosen in order that earlier researches showed, that stepped shape waveguide has highest amplitude magnification factor of the generated vibrations (comparing to cylindrical, conical, exponential, reversed exponential shapes) and surface area with greater cross sectional area moves in the most uniformity way in the longitudinal direction when excitation conditions are the same [8].

4. Experimental research of ultrasonic motor control using burst type signal generator

In order to investigate control of USM using burst type signal generator experimental research was carried out. A scheme and setup view of experimental research are presented in Fig. 4.

During experimental (set-up given in Fig. 4a) research shock exciter 2 (piezoelectric stack, made of 46 piezo rings, dimensions Ø23xØ13x0.5 mm, material PZT-5, total capacity of 260 nF), was charged by DC power supply 1 (Mastech HY5003 with laboratory voltage amplifier) in voltage range 315-470 V. After that the shock was generated by shortening the contacts of shock exciter 2. Generated shock energy throw stepped-exponential shape waveguide 3

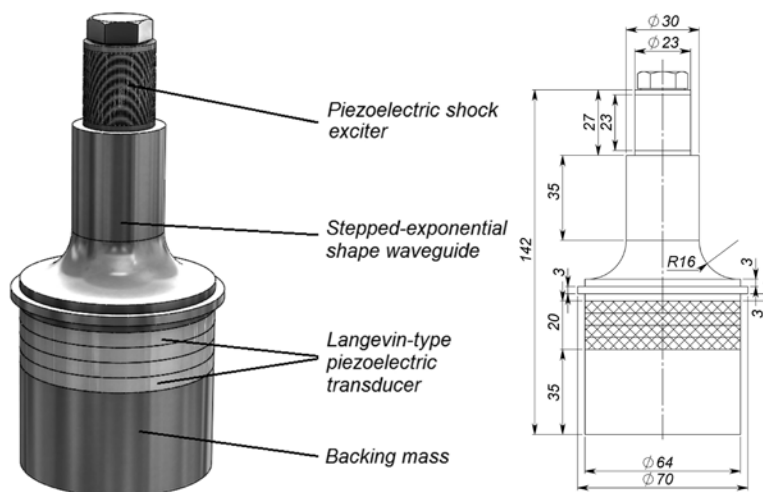

Fig. 2. 3D model view and drawing of fabricated burst type signal generator

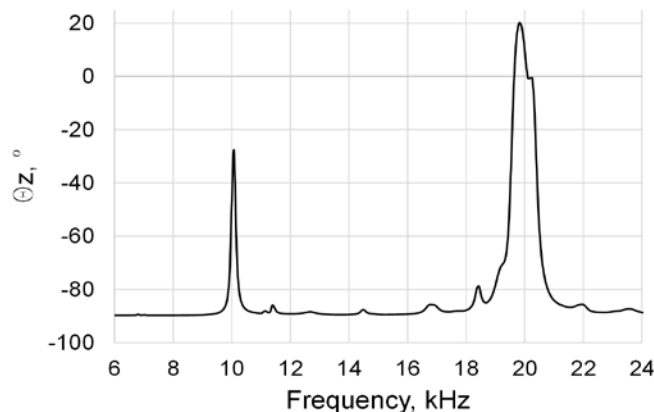

Fig. 3. Impedance of designed burst type signal generator

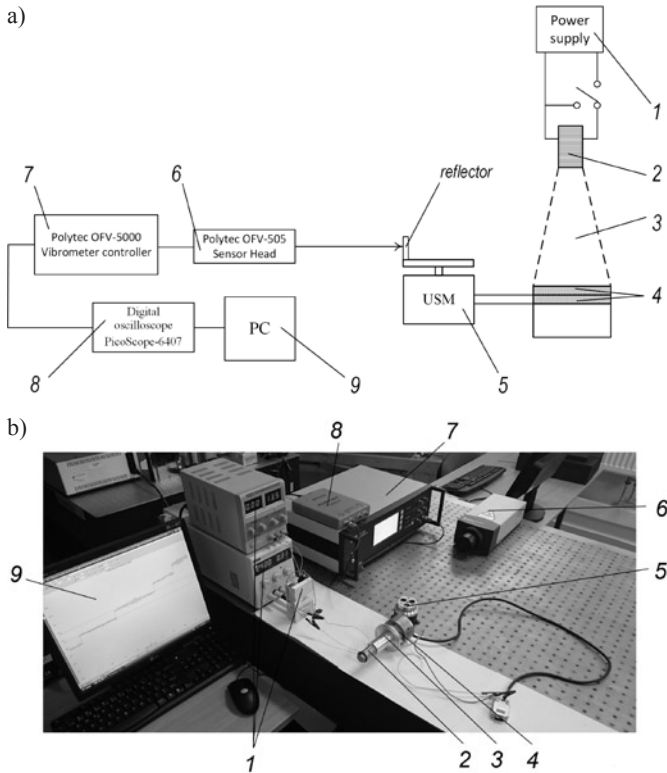

Fig. 4. Experimental research of burst type signal generator for USM control a) scheme b) setup view: 1 – power supply, 2 – shock exciter, 3 – stepped-exponential shape waveguide, 4 – Langevin-type piezoelectric transducer, 5 – USM, 6, 7 – Laser vibrometer, 8 – Digital oscilloscope, 9 – PC

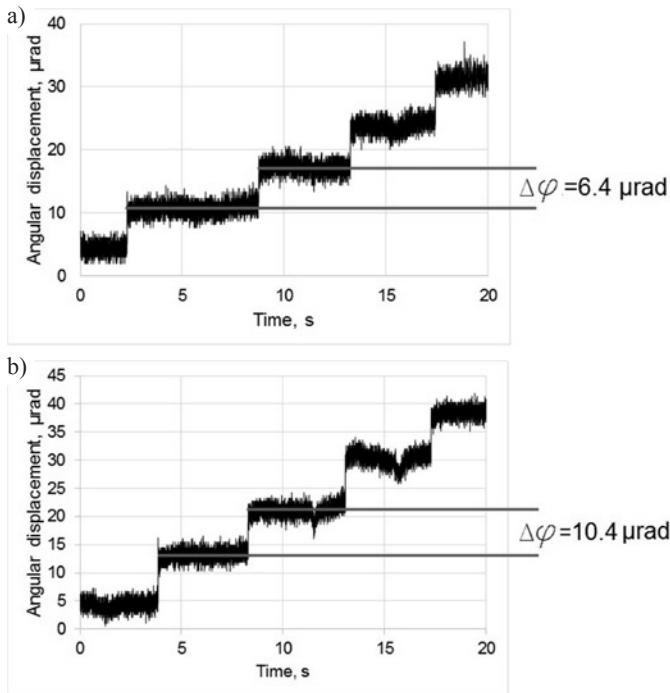

Fig. 5. Experimental results – motor rotational steps: a) shock exciter before shortening charged by 370 V, b) shock exciter before shortening charged by 470 V

was dispersed and smoothly transmitted to piezoelectric Langevin-type transducer 4, consists of 4 piezoelectric rings made of PZT-5, with total capacity of 6.56 nF. Generated electrical energy from this transducer was directly transmitted to USM 5 and motor movement was obtained. USM movement was measured with laser vibrometer

6-7 (Polytec OFV-5000/505), data acquisition was made with digital oscilloscope 8 (PicoScope-6407) and PC 9. During experimental research sensitivity of Polytec vibrometer was 2 μm/V.

Experimental results – motor rotational steps when shock exciter before shortening was charged by 370 V or by 470 V are presented in Fig. 5.

Experimental results showed that the higher charging voltage of shock exciter was, the higher motors steps were obtained. The lowest rotational step was obtained at the lowest used – 315V charging voltage and was 1.55 μrad. The highest rotational step was 10.4 μrad when charging voltage was 470 V. The higher charging voltage is not allowed due to shock exciter technical characteristics.

5. Experimental research of power circuit of shock exciter using additional capacitor

In order to obtain more than one ultrasonic motor step per one charge of shock exciter, new technique for shock exciter power circuit was proposed. Scheme of proposed power circuit of shock exciter and experimental setup view are presented in Fig. 6.

Such a power circuit of shock exciter (Fig. 6) has some kind of DC power supply 1 (e.g. solar panels, thermoelectric panels, etc.), additional capacitor of 100 μF 2, switch 3, shock exciter 4, stepped-exponential shape waveguide 5, Langevin-type piezoelectric transducer 6, with total capacity of 6.56 nF, USM 7 (resonant frequency 20.2 kHz), laser vibrometer 8-9 (Polytec OFV-5000/505), digital oscilloscope 10 (PicoScope 6407), PC – 11.

Working principle of such scheme is as follows: at the beginning additional capacitor, which is located between power supply and shock exciter, is charged from some kind of DC power supply, in this case Mastech HY5003, up to 470 V. After that shock exciter contacts are shortened in different direction after every step of motor and in this way shock is obtained from one charge of additional capacitor.

Experimental results showed that presented technique for shock exciter control (Fig 6) works correctly and generates up to 30 ultrasonic motors steps per one electric charge of additional capacitor C_{add} . The highest step, the

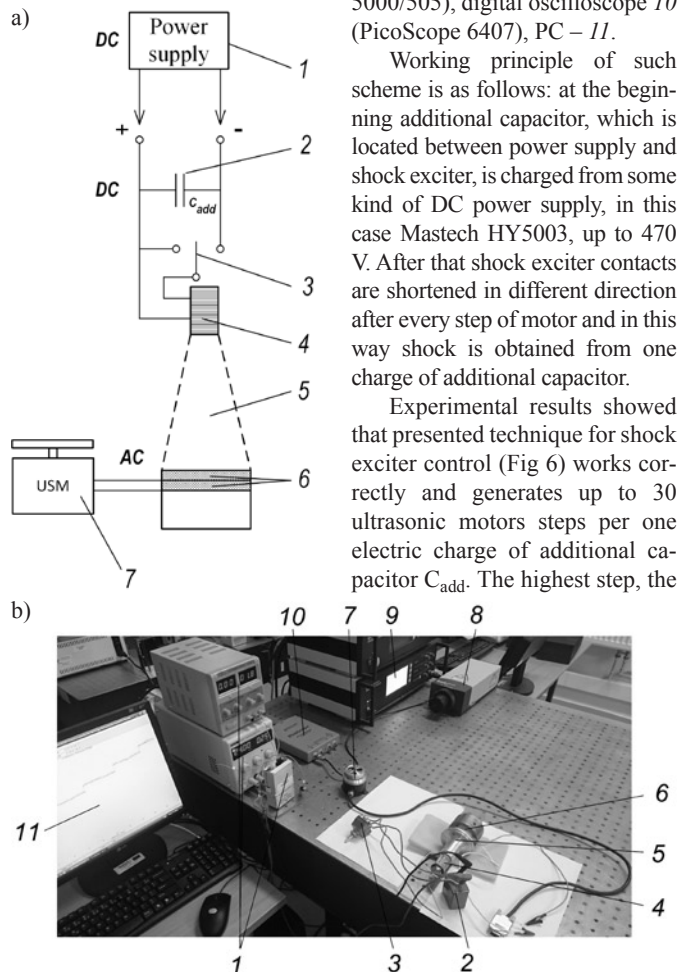

Fig. 6. Power circuit of shock exciter: a) scheme of burst type signal generator with additional capacitor; b) experimental setup view: 1 – power supply, 2 – additional capacitor, 3 – switch, 4 – shock exciter, 5 – stepped-exponential shape waveguide, 6 – Langevin-type piezoelectric transducer, 7 – USM, 8,9 – laser vibrometer, 10 – digital oscilloscope, 11 – PC

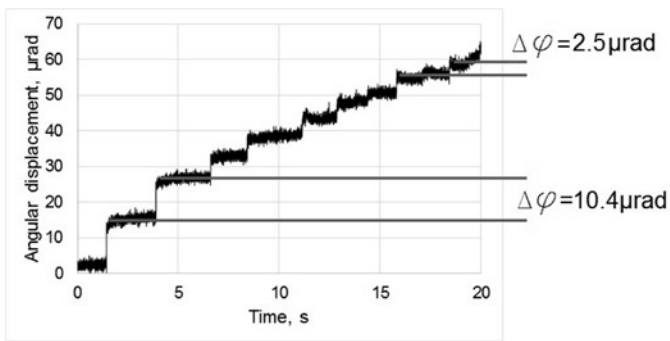

Fig. 7. Experimental results – the last 10 motor rotational steps (of 30 steps) per one electric charge of additional capacitor up to 470 V

same as in experimental research without additional capacitor, was obtained at the first step – 10.4 μrad and was the same until the 21st. The lowest was the 30th step – 2.5 μrad .

Obtained results – the last 10 motor rotational steps, of total 30, obtained during experimental research, per one electric charge of additional capacitor (up to 470 V) are presented in Fig. 7.

Such a power circuit could be used and especially helpful in areas, where traditional DC power supply is unavailable, e.g. in space or nature, where alternative energy supply, such as solar or etc. could be used. For example, solar panels through certain control circuit could charge additional capacitor and after that ultrasonic motors steps could be obtained without recharge after every step.

References

1. Cornogolub A, Cottinet P J, Petit L. Analytical modeling of curved piezoelectric, Langevin-type, vibrating transducers using transfer matrices. *Sensors and Actuators A-Physical* 2014; 214: 120-133.
2. Glazounov A E, Zhang Q M, Kim C. Torsional actuator and stepper motor based on piezoelectric d15 shear response. *Journal of intelligent material systems and structures* 2000; 11: 456-468.
3. Lizhong X, Jichun X. Forced response of the inertial piezoelectric rotary motor to electric excitation. *Journal of Mechanical Science and Technology* 2015; 29: 4601-4610.
4. Morita T. Miniature piezoelectric motors. *Sensors and Actuators A-Physical* 2003; 103: 291-300.
5. Shine-Tzong H, Shan-Jay J. A piezoelectric motor for precision positioning applications. *Precision Engineering* 2016; 43: 285-293.
6. Shine-Tzong H, Wei-Hsuan C. A piezoelectric screw-driven motor operating in shear vibration modes. *Journal of Intelligent Material Systems and Structures* 2016; 27: 134-145.
7. Shupeng W, Zhihui Z, Luquan R, Hongwei Z, Yunhong L, Bing Z. Design and driving characteristic researches of a novel bionic stepping piezoelectric actuator with large load capacity based on clamping blocks. *Microsystem Technologies* 2015; 21: 1757-1765.
8. Wang D A, Nguyen H D. A planar Bézier profiled horn for reducing penetration force in ultrasonic cutting. *Ultrasonics* 2014; 54: 375-384.
9. Yingxiang L, Dongmei X, Zhaoyang Y, Jipeng Y, Xiaohui Y, Weishan C. A Novel Rotary Piezoelectric Motor Using First Bending Hybrid Transducers. *Applied sciences* 2015; 5: 472-484.
10. Yingxiang L, Xiaohui Y, Weishan C, Junkao L. A rotary piezoelectric actuator using longitudinal and bending hybrid transducer. *AIP Advances* 2012; 2: 042136.
11. Yu-Jen W, Yi-Cheng C, Sheng-Chih S. Design and analysis of a standing-wave trapezoidal ultrasonic linear motor. *Journal of Intelligent Material Systems and Structures* 2015; 26: 2295-2303.

Darius EIDUKYNAS

Vytautas JÜRĖNAS

Institute of Mechatronics

Kaunas University of Technology

Studentu str., 56-106 Kaunas, Lithuania

Egidijus DRAGAŠIUS

Faculty of Mechanical Engineering and Design

Kaunas University of Technology

Studentu str., 56-321 Kaunas, Lithuania

Arkadiusz MYSTKOWSKI

Faculty of Mechanical Engineering

Bialystok University of Technology

ul. Wiejska 45C, 15-351 Bialystok, Poland

E-mails: darius.eidukynas@ktu.edu, vytautas.jurenas@ktu.

lt, egidijus.dragasius@ktu.lt, a.mystkowski@pb.edu.pl