



Piotr Antoniak

Wrocław University of Science and Technology, Faculty of Mechanical Engineering, Department of Mechanical Engineering and Tribology
ul. Łukasiewicza 7/9, 50-371 Wrocław, Poland, piotr.antoniak@pwr.edu.pl

Michał Stosiak

Wrocław University of Science and Technology, Faculty of Mechanical Engineering, Department of Maintenance and Operation of Logistics, Transportation and Hydraulic Systems,
ul. Łukasiewicza 7/9, 50-371 Wrocław, Poland, michal.stosiak@pwr.edu.pl
 <https://orcid.org/0000-0002-6111-1332>

Krzysztof Towarnicki

Wrocław University of Science and Technology, Faculty of Mechanical Engineering, Department of Maintenance and Operation of Logistics, Transportation and Hydraulic Systems,
ul. Łukasiewicza 7/9, 50-371 Wrocław, Poland, krzysztof.towarnicki@pwr.edu.pl
 <https://orcid.org/0000-0002-4881-2548>

PRELIMINARY TESTING OF THE INTERNAL GEAR PUMP WITH MODIFICATIONS OF THE SICKLE INSERT

Abstract

This paper presents the modifications that have been made to the sickle insert of the gear pump with internal gearing. This procedure allowed the obtainment of radial compensation. The test stand to plot the characteristics of the pump before, as well as after the first and second modification is discussed. The results of the measurements from the tests conducted are presented. The results obtained confirmed the achievement of radial compensation by cutting the appropriate channel in the sickle insert. As a result, it will be possible to obtain a higher discharge pressure for this type of pump and to increase its efficiency.

Key words

Gear pump, capacity, internal gearing, sickle insert.

Introduction

The pump is the main elementary component of the hydraulic system. Its operation is based on the conversion of external mechanical energy (for example, obtained from an electric or combustion engine) into hydraulic energy accumulated in the liquid. Its work comes down to sucking the liquid from the inlet, and then transferring it by the pump's working elements into the pressure port. Proper operation of the pump is guaranteed by a hermetically separation of the suction and pressure area. The impermeable separation of the two spaces allows the pressure of the transported liquid to be increased. The coupling of construction elements causes the rotation of the rotor simultaneously causing the displacement of the liquid mass. When the rotor stops, the flow of the working medium becomes unfeasible. The purpose of the pump is to provide two functions: transporting the liquid from the suction port to the discharge port, and increasing its pressure. The gear pump is one of the most commonly used positive displacement pumps in hydrostatic drive systems. The current development of hydraulic technology is based on the widespread introduction of electronic and automatic systems in machinery construction. An attribute of hydrostatic drive systems is the broad possibility of broad control of the speed and power of receivers. The placement of modern, multi-level electronic systems in hydraulic systems has contributed to smooth regulation and a significant reduction of their noise. Today's development of hydraulic drives is mainly based on the optimization of the construction of hydraulic drive system components. This mainly applies to two directions: a) minimizing their mass, which is associated with a reduction in their dimensions or the use of new lightweight and high-strength composite material [1], b) reduction of their noise [2]. The reduction of the dimensions or weight of hydraulic components while maintaining the current operating parameters (nominal pressures, efficiency, resistance to operating conditions) is included in the downsizing trend. The development trend aimed at minimizing dimensions has taken the name of microhydraulics. Over the last several years, significant development of microhydraulic systems has been noted in the literature [3], and the development of displacement micropumps contributed to this development. Requirements that have been

set for them are: little geometric displacement, the ability to generate high pressures, small changes in efficiency along with an increase in generated pressure, possibly small flow pulsation resulting in low pressure pulsation, high efficiency and durability, resistance to oil contamination, and relatively low manufacturing costs. The above requirements are generally met by gear pumps. They can be used not only in hydrostatic drives, but also as metering elements for viscous liquids found in the automotive, chemical, food and pharmaceutical industries. [4]. It was adopted, although it is a contractual and constantly evolving, that microhydraulic elements are those in which the nominal flow is below $50 \text{ cm}^3 / \text{s}$ ($3 \text{ dm}^3 / \text{min}$) or the nominal size is $WN < 6$ (for microhydraulic valves). Another trend in the construction of hydraulic components is the use of new materials, for example, for pump bodies, valves or hydraulic cylinders. Research is being carried out on the application of polyoxymethylene (POM) in the construction of the above elements [5]. The main objective is to minimize the element's mass when achieving comparable operating parameters (for example, nominal operating pressures for actuators of 30 MPa and more). The advantages of hydrostatic drives include the exceptionally high density of the transmitted power stream in the drive system. Values of operating pressures of $35 \div 40 \text{ MPa}$ are now something completely normal. At these pressures, power of 1 kW can be obtained from the spray liquid stream with a volume flow rate of only $30 \div 25 \text{ cm}^3 / \text{s}$ ($1.8 \div 1.5 \text{ dm}^3 / \text{min}$). The elements of the hydrostatic drive system have, therefore, compactness that is unachievable for other types of drive, i.e. a small mass per unit of power generated or transmitted. The development trends of hydrostatic drives are heading, among others, towards minimizing energy loss and mass, and increasing transferred power, thus increasing the power to mass ratio [6]. Weight reduction of high-pressure components and systems (including hydraulic ones) is particularly important in aircraft and mobile machines. On the other hand, micro-hydraulic systems have increased the requirements regarding the accuracy of operation of the receivers or silent operation. This requires an assessment of the impact of external mechanical vibrations on microhydraulic elements, and a search for ways to reduce this impact, for example, by the methods of vibration insulation of microhydraulic valves. An unquestionable advantage of hydraulic systems is the transfer of high power, which is associated with the generation of high pressures. Hydraulic gear units – pumps and motors – are widely used in hydrostatic drive systems [7]. Due to their simple construction, relatively low price and high durability, gear pumps are widely used. To ensure high pressure, axial and radial compensation are introduced. Radial compensation in external gearing pumps has been known for years. One Polish description shows a symmetrical version in the pump body on both sides of the pumping chamber, along the working chamber of two channels separated from the working chamber by flexible tongues. This radial compensation solution only applies to pumps with external gearing. In a German patent specification, one can find the introduction of radial compensation through the distinctive construction of the sickle pad. There are several design solutions that, irrespective of the type of design, consist of many elements. When the pressure in the pump pressure chamber increases, the insert elements are pressed against the surfaces of the tops of the meshing gears. To ensure high efficiency of the gear pump, it is essential to introduce both axial and radial compensation. Axial compensation is used most often because it is inexpensive and relatively easy to make. Because of the cost, radial compensation is used less often.

Materials and methods

Figure 1 shows a pump with internal gearing. The operation of the pump consists of rotating the outer gear (2). The next step is the rotation of the gearing rim (1) with the internal gearing. Between the wheel and the gearing ring there is a sickle insert (5), which closely touches the top of the gears. In order to secure the sickle insert, a safety peg (6) was placed in it. As a result of the rotation of the gear wheel (as in Figure 1), the liquid is transported in interdental gaps from the suction space (7) to the pressure space (4). Displacement of liquids occurs when the wheel gear enter the gap's interdental rim. After passing the teeth in the meshing, they come out of the interdental gaps and are filled with liquid in the suction space (7). Separation of the suction space from the pressing space is obtained through the contact between the gearing of the wheel (2) and the rim (1) (above) and the sickle insert (5) (below). The main properties of this type of pumps are: lower noise emission, more-even performance, and a more-compact design compared with pumps with external gearing. Thanks to the fact that the external and internal gears work together, a very high degree of gear coverage and favorable sealing at their contact point is obtained due to the increased circumference of the wheels in contact with the suction and pressure spaces. The advantage of high coverage results in smoother pump operation, reduced fill losses, reduced output and pressure pulsations, and lower noise levels. The result of this advantage is continuous work aimed at increasing the efficiency of these pumps and achieving higher pumping pressures [9].

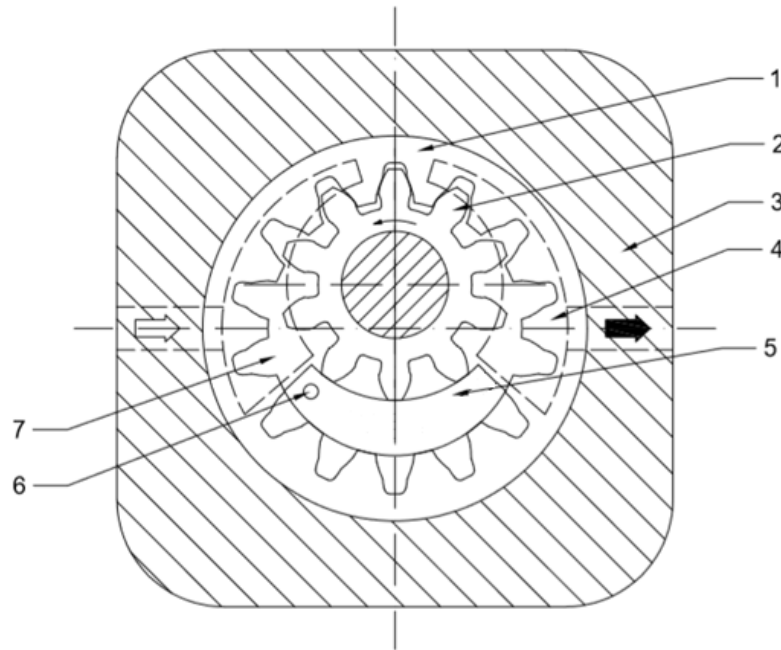

Figure 1. General scheme of a gear pump with internal gearing. 1 – gear wheel, 2 – gear wheel, 3 – pump body, 4 – pressure space, 5 – sickle insert, 6 – protection pin, 7 – suction space.

Source: Author's own work

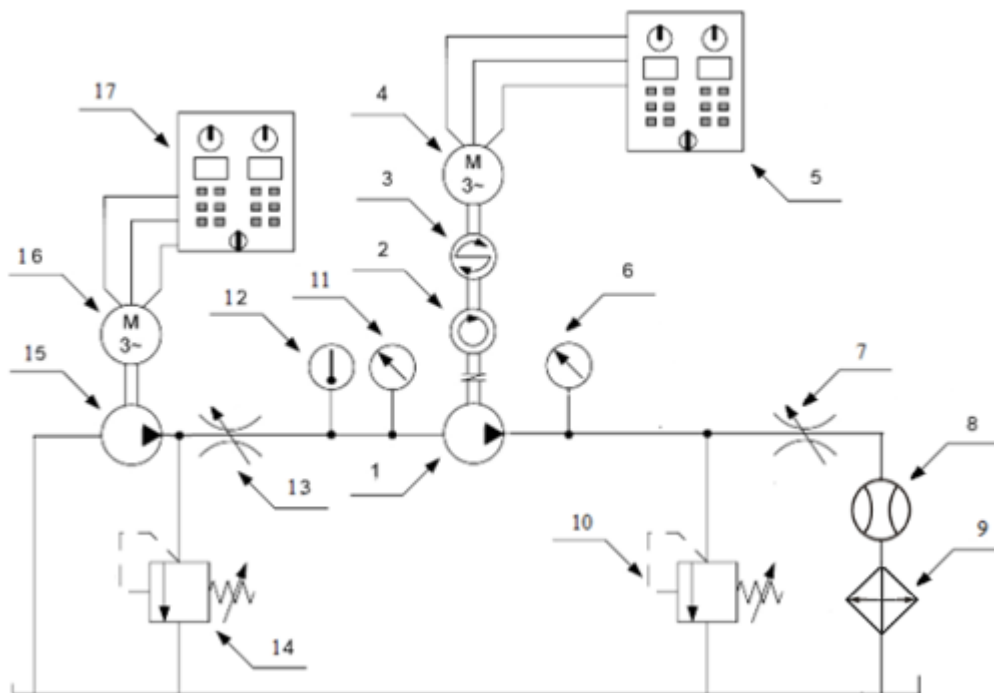

Figure 2. Hydraulic diagram of the test system. 1 – gear pump tested, 2 – tachometer, 3 – torque meter, 4 – electric motor, 5 – control cabinet, 6 – pressure transducer, 7 – throttle valve, 8 – flowmeter, 9 – cooler, 10 – safety valve, 11 – pressure transducer, 12 – thermometer, 13 – throttle valve on the discharge line of the feed pump, 14 – safety valve on the discharge line of the feed pump, 15 – feed pump, 16 – electric motor driving the feed pump, 17 – control cabinet of the electric motor driving the feed pump.

Source: [10]

Figure 2 above shows a diagram of the measuring system. The supercharging pump (15) at the feed of the tested pump allowed the maintenance of constant pressure at the suction port of the tested pump, measured with a pressure transducer 11(WIKA A-10). To protect pump 1, a safety valve (10) is installed in the system. A throttle

valve (7) was used to load the pump under test. A flow meter (8) (KRACHT VC0.2) was used to measure the actual pump performance, and a pressure transducer (6) (WIKA A-10) was used to measure the pressure. A torque meter (3) (HBM T22/10Nm) was used to measure the generated torque on the pump shaft. A magnetic sensor located on the shaft of the torque meter was used to measure the rotational speed of the pump. A flexible coupling was shown between the engine and the torque meter, as shown in Figure 2. A measuring system was used to record the torque and rotational speed in real time. The pump under test consists of two wheels. The gear wheel with external gearing has 13 teeth, and the gear wheel with internal gearing has 16 teeth. A test measurement was carried out, during which the correctness of the pump, safety valve and indications of all measuring instruments was checked. Following this, a series of correct measurements was made and pump characteristics were plotted. Three rotational speeds of the pump shaft were adopted for measurements, The tests were carried out at three rotational speeds of the gear pump shaft and the load was carried out for p_t from six to 20 bar in steps of one bar due to the pump body and modified plastic sickle insert. The recording of measurements was carried out after the pump operating conditions had stabilized. The tests were carried out at a constant working medium temperature of 333 K. The measurements were recorded using measuring instruments, partly connected to the computer, which facilitated the archiving of results. Microsoft Excel was used to process the measurement data.

Results and discussion

The results of the measurements are presented below.

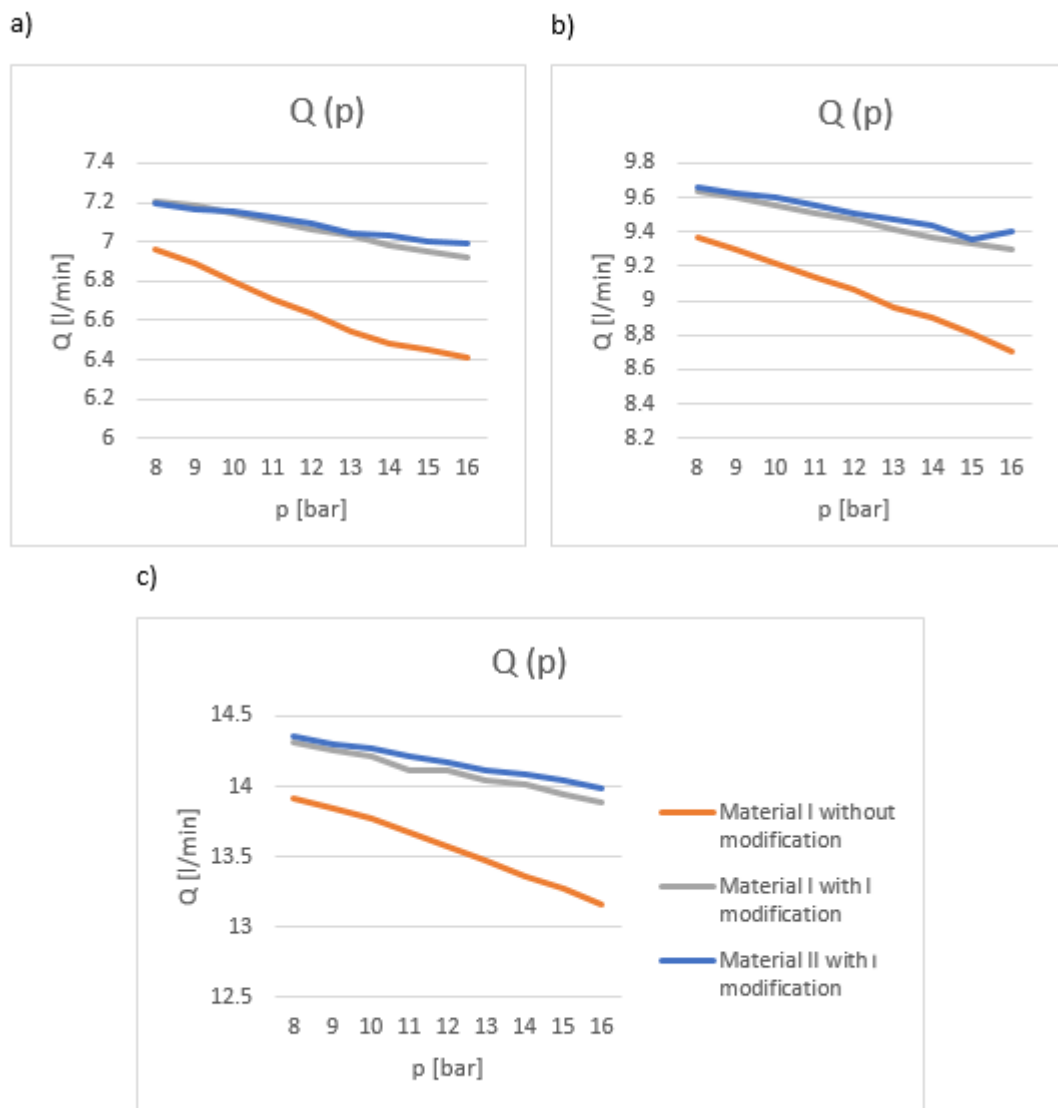

Figure 3. Characteristics of the gear pump with internal gearing with I modification sickle insert at different rotational speeds of the pump shaft: a) $n = 750$ [rpm] b) $n = 1000$ [rpm] c) $n = 1500$ [rpm].

Source: [10]

A hydraulic measuring system was built for basic measurements on the pump discharge line. The prototype pump differs from a conventional pump in modifications to the sickle insert. The modification consists of making the channel in a sickle pad, thanks to which two slides were created. Measurements were carried out on one pump construction; only the sickle pads were replaced during subsequent measurements. The base insert was made of POM plastic without modification, the next one was also made of POM plastic, but with modification, and another one made of PA plastic with modification. Each time the pump was assembled, its structural elements were bolted together with the same torque of 20 Nm. Analyzing the measurements, it can be stated that the modification introduced allows maintaining the pump capacity with increasing pressure. When the pump is operated with a base sickle pad without incisions, it can be stated that the flow rate decrease with increasing pumping pressure is higher than for a pump with a modified insert. During the operation of the pump with modified inserts, i.e. with notches, an increase in the pump's efficiency is noted compared with the operation of the pump with a base insert. Modification No. I consisted of creating a one half channel long sickle insert. Modification No. II consisted of creating a one-quarter hannel length of the sickle insert. After measurements and verification, it was decided to make longer channels with a length equal to half the length of the sickle insert. The following are the measurement results for both modifications and both materials for three rotational speeds.

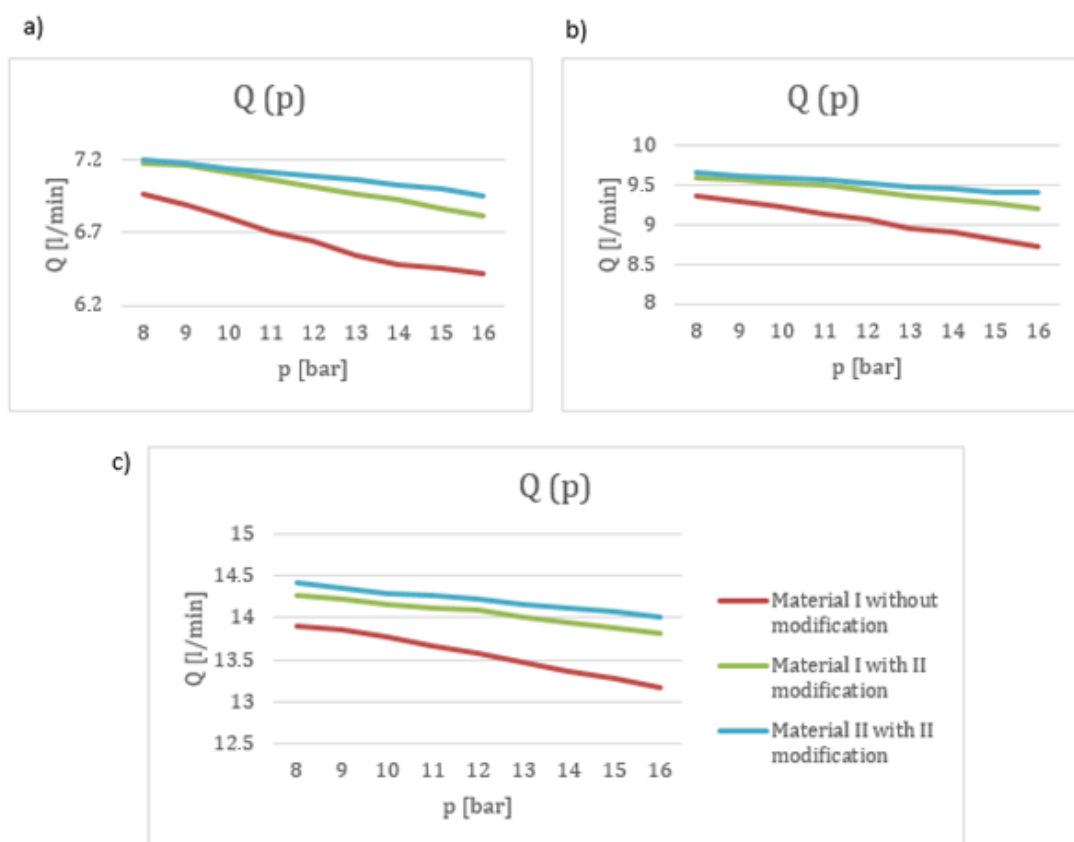

Figure 4. Characteristics of the gear pump with internal gearing with II modification sickle insert at different rotational speeds of the pump shaft: a) $n = 750$ [rpm] b) $n = 1000$ [rpm] c) $n = 1500$ [rpm].

Source: Author's own work

Comparing the measurements for two different modifications, it can be concluded that a small incision in the channel inside the insert causes an increase in volumetric efficiency compared with a conventional solution. In both cases, a higher efficiency is obtained for a pump with an insert made of material II. This is due to the properties of this material, mainly thermal expansion and specific heat and moisture absorption, which it is characterized by. Different thermal expansion changes the geometry of the gaps in the pump, which changes internal leakage. The applied modification has a positive effect on the characteristics of this gear pump, i.e. a slight decrease in efficiency as pressure increases. The feature presented refers to the two materials used; therefore, this is mainly due to its geometrical features, and to a lesser extent the material. The main reason for the decrease in performance as the pressure increases in conventional pumps is due to the increase in the gap between the surface of the insert and the surface of the gears. The incision in the sickle insert causes the guide

to be pressed against the surface of the tops of the gears, reducing the gap as the pressure increases. This increases the volume efficiency. The measurements were carried out for a narrow pressure range with a relatively low value, so the differences are not very significant. A pump with a Plexiglas plastic body was used for the measurements, so higher pressure could not be generated at the pump discharge port. In the future, further measurements are planned for the steel pump. The above tests were carried out for a gear pump with compensation of radial clearances by introducing an incision in the sickle insert. This type of pump is used to generate the flow rate and generate pressure in the liquid stream in all types of hydraulic drive systems and lubrication systems. On this basis, it can be anticipated that the described modification can be readily implemented in pump designs.

Summary and conclusions

The current trend in the construction of hydraulic drive systems imposes the use of higher operating pressures. For this reason, pump manufacturers are required to introduce radial compensation to achieve higher discharge pressure. The modification presented consists of making a channel over the entire width of the insert, dividing it into two flexible slides. The channel inlet is located on the pump pressure side. When the pressure in the pressure chamber increases, the flexible tongues are pressed against the surfaces of the gear tops. To protect the insert from sliding, a pin located in the pump body was used. The advantage of the introduced design change is simple radial compensation, which results in a smaller decrease in efficiency as the discharge pressure increases. This solution is the subject of patent application No. P. 431145. The first modification consisted of making a channel with a length of one-quarter of the length of the sickle insert. After the measurements and verification, it was decided to make longer channels with a length equal to half the length of the sickle insert. The measurement results presented in the article confirm the correctness of the above conclusions. If the insert of material II is made, a higher volumetric efficiency is obtained. Pumps with modified inserts are characterized by higher volumetric efficiency values than pumps without. Based on the measurements carried out, another concept for the next modification of the sickle insert was created. The essence of this solution is to make a channel inside the sickle insert with two different widths. The described solution is the subject of patent application No. P. 431146. The entrance to the channel chamber is located on the pressure chamber side. Inside the channel there is a piston, which on one side is supported by a spring, and on the other by the pressure prevailing in the discharge port of the pump. The piston moves as the pressure in the pump's pressure chamber increases. When the pressure drops, the piston will return to its original position by means of a spring. As a result of the sickle insert change, two flexible slides will be created in the sickle insert. Such a design change of the sickle insert will allow a reduction of the efficiency drop along with an increase of the pump discharge pressure, and will increase its efficiency irrespective of the change of pressure and pump rotation. While maintaining the hydraulic-mechanical efficiency, the overall performance of the modified device will increase. This contributes to further increasing the competitiveness of a gear pump with internal gearing pumps compared with a gear pump with external gearing. The described modification will allow the construction of high-pressure toothed micro-pumps with internal meshing. Micropumps are built on the basis of classic pumps. The requirements for micro pumps are: low geometric displacement, obtaining high pressures, small changes in efficiency with increasing pressure, high efficiency and durability, resistance to oil contamination, and low production costs. They are used in the drive systems and lubrication systems of machines and vehicles. They are distinguished by high working pressures reaching 35 MPa and volumetric efficiency exceeding 90%. Further unquestionable advantages are their long life and the ability to pump liquids at high rotational speeds, which places them first among positive displacement pumps. The elementary division of gear pumps divides them into gear pumps with external and internal gearing [11]. A special type of gear pump with internal gearing is a gerotor pump. Their distinctive feature is the absence of a sickle insert, thanks to which they are characterized by a very compact construction, resulting in smaller sizes and less mass. In addition, they are characterized by high efficiency, with small and light units, and are reliable and durable. Pumps commonly used in the industry are gear pumps with external gearing, which is due to their simple design and low price. The use of pumps with internal gearing is becoming increasingly popular [12].

References

- [1] W. Błażejowski, M. Lubecki, P. Mayer, M. Stosiak and K. Towarnicki, The use of new materials in elements and hydraulic systems, NiSHiP conference materials, Center for Appraisal and Personnel Development of the SIMP Branch in Wrocław, [2018]. pp. 23-24.
- [2] W. Fiebig and M. Korzyb, Vibration and dynamic loads in external gear pumps. Archives of Civil and Mechanical Engineering. 2015, vol. 15, No. 3, pp. 680-688
- [3] W. Kollek, P. Osinski, M. Stosiak, A. Wilczyński and P. Cichon: Problems relating to high-pressure gear micropumps. Archives of Civil and Mechanical Engineering (14) 2014, pp. 88-95.
- [4] W. Kollek, Fundamentals of design, modeling, operation of microhydraulic components and systems (In Polish). Oficyna Wydawnicza PWR, Wrocław, 2011, 2 - Mikrohydraulika, Hydraulika i Pneumatyka, nr 6/1999
- [5] J. Stryczek, M. Banaś, J. Krawczyk, L. Marciniak, P. Stryczek: The fluid power elements and systems made of plastics. Procedia Engineering, 2017, vol. 176, pp. 600-609
- [6] Entwicklung der Hydraulik für mobile Anwendungen. 12 A FK Aachen 1996.
- [7] P. Śliwiński, New satellite pumps. Key Engineering Materials, vol. 490 (2012) pp. 195-205
- [8] M. Rundo, Theoretical flow rate in crescent pumps, Simulation Modelling Practice and Theory, vol. 71, February 2017, pp. 1-14
- [9] E. B. Lewis, H. Cyndi, Selecting internal gear pumps for difficult duties. World Pumps, vol. 2005, Issue 462, March 2005, pp. 26-27
- [10] P. Antoniuk, M. Stosiak, K. Towarnicki, Preliminary testing of the gear pump with internal gearing with modification of the sickle insert, In: Engineering Mechanics 2019 : 25th international conference. May 13-16, 2019, Svratka, Institute of Thermomechanics of the Czech Academy of Sciences, 2019. pp. 33-36.
- [11] R. P. Lambeck, Hydraulic pumps and motors. Marcel Dekker INC, New York (1983)
- [12] J. Stryczek, S. Bednarczyk and K. Biernacki, Gerotor pump with POM gears: design, production technology, research. Archives of Civil and Mechanical Engineering. 2014, vol. 14, No. 3, pp. 391-397