

Georgi VUKOV, Zhivko GOCHEV

INVESTIGATIONS OF THE SPACE VIBRATIONS OF A WOODWORKING SHAPER

The proposed study investigates the spatial vibrations of a woodworking shaper. It presents an original mechanic-mathematical model targeted to investigations of the spatial vibrations of woodworking shapers, developed by the authors. The model considers woodworking shapers with lower placement of the spindle. In this model the woodworking shaper, the spindle and the electric motor's rotor are regarded as rigid bodies, which are connected by elastic and damping elements with each other and with the motionless floor. The model takes into account the needed mass, inertia, elastic and damping properties of the elements of the considered system. It includes all necessary geometric parameters of this system. After that a system of matrix differential equations is compiled and analytical solutions are derived. Numerical calculations are carried out by using the developed model and modern computer programs. The calculations use the parameters of a machine used in practice. As a result of the whole study, the natural frequencies and the mode shapes of the free spatial vibrations of the studied mechanical system are calculated and illustrated. Then the free damped spatial vibrations of this system are obtained and illustrated also.

Keywords: woodworking shapers, spatial vibrations

Introduction

The tendency to significantly reduction of the level of the vibrations and the noise accompanying the work of modern woodworking machines in recent years implies expanding and deepening the research of the dynamic processes in these machines. The specificity of the work of woodworking shapers implies frequent passing through transient regimes. It turns out that studying the characteristics of these regimes is especially important to ensure the proper machine's work [Veits et al. 1971; Orłowski et al. 2007; Barčík et al. 2011; Kminiak et al. 2016]. Consequently, a careful study of damped vibrations of this machine is required [Gochev and Vukov 2017; Gochev et al. 2017]. Investigations of these vibrations facilitate selecting of some of the woodworking shaper's components and aid the control of its technical state [Minchev and Grigorov 1998; Beljo-Lučić and

Goglia 2001; Barčík et al. 2011]. This mainly concerns the vibroisolators between the machine and the floor, as well as the bearing units of the spindle and the rotor of the electric motor [Stevens 2007]. Such a study can be done numerically with the parameters of a particular woodworking shaper [Nikravesh 1988; Shabana 2005; Vukov et al. 2016]. It is based on a previously developed mechanic-mathematical model of this machine [Coutinho 2001; Amirouche 2006; Angelov 2011].

The proposed study considers the class of woodworking shapers with a lower spindle position, which are often used in practice of the forestry industry. The analysis of their construction shows the strong interconnection between the work of spindle with mounted tool on it, the rotor of the drive motor and the operation of the whole machine. The idea that the woodworking shaper, its spindle and the electric motor's rotor are regarded as rigid bodies, which are connected by elastic and damping elements with each other and with the motionless floor, derives from this analysis. These elastic and damping elements are four-vibration isolators between the machine and the floor, two bearing units of the spindle and two bearing units of the electric motor's rotor.

The aim of this study is to investigate the spatial vibrations of the woodworking shaper. Therefore, first it is necessary to develop mechanic – mathematical model of the woodworking shaper, its spindle and the rotor of the driving electric motor. The model should take into account the characteristics of the woodworking shaper construction, the mass, inertia, elastic and damping properties of its components as well as all needed geometric parameters of the system. A system of matrix differential equations is composed on the basis of this model and analytical solutions are presented. Numerical calculations are carried out by using the developed model and modern computer programs. The calculations use the parameters of a real machine. The obtained results are illustrated graphically so as to make their analysis easier.

Materials and methods

This study examines the class of woodworking shapers with a low positioned spindle, which are often used in the practice of the forestry industry [Filipov 1977; Obreshkov 1996]. The analysis of their construction shows the strong influence of the spindle and the drive motor on the operation of the whole machine. Figure 1 shows the general view of woodworking shapers. Figure 2 shows a scheme of this type of woodworking shapers. The machine's body is marked with 1, 2 is the drive electric motor, 3 – the belt drive, 4 – the vibration isolators between the machine and the floor, 5 – the spindle with the bearings, 6 – wood shaper's saw.

Figure 3 shows the spindle with its bearing units. Figure 4 shows the spindle with fitted cutter. Figure 5 shows the drive electric motor.

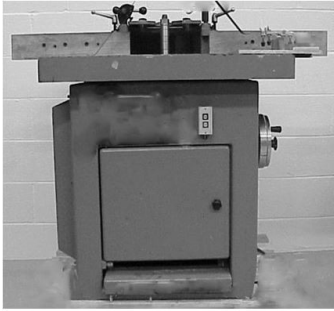

Fig. 1. General view of wood shaper

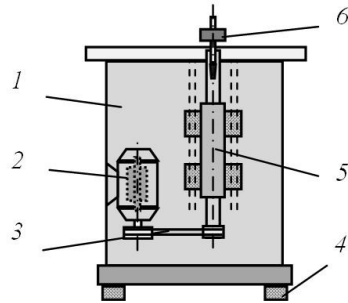

Fig. 2. Scheme of wood shapers

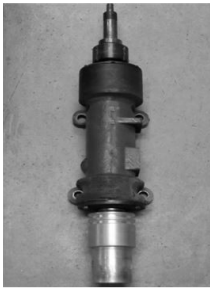

Fig. 3. Spindle with its bearing units

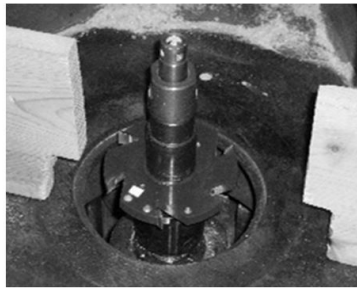

Fig. 4. Spindle with fitted cutter



Fig. 5. Drive electric motor

In the following discussions, the woodworking shaper, its spindle and the rotor of the driving electric motor are regarded as rigid bodies, which are connected by elastic and damping elements with each other and with the motionless floor. These elastic and damping elements are the four vibration isolators between the machine and the floor, the two bearing units of the spindle, and the two bearing units of the electric motor's rotor.

A mechanic-mathematical model of wood shapers with lower spindle is built for studying its free damped spatial vibrations. The model is shown in Figure 6. The following symbols are used:

m_1, m_2, m_3 – mass of the woodworking shaper, the spindle and the rotor of the driving electric motor;

$I_{\theta\theta}^1, I_{\theta\theta}^2, I_{\theta\theta}^3$ – inertia moment tensors of the woodworking shaper, the spindle and the rotor of the driving electric motor;

$c_{x1i}, c_{y1i}, c_{z1i}, i = 1, 2, 3, 4$ – elastic coefficients of the vibroisolators between the machine and the floor;

$b_{x1i}, b_{y1i}, b_{z1i}, i = 1, 2, 3, 4$ – damping coefficients of the vibroisolators between the machine and the floor;

c_{x2i} c_{y2i} c_{z2i} , $i = 1, 2$ – elastic coefficients between the body of the machine and the spindle;

b_{x2i} b_{y2i} b_{z2i} , $i = 1, 2$ – damping coefficients between the body of the machine and the spindle;

c_{x3i} c_{y3i} c_{z3i} , $i = 1, 2$ – elastic coefficients between the body of the machine and the rotor of the driving electric motor;

b_{x3i} b_{y3i} b_{z3i} , $i = 1, 2$ – damping coefficients between the body of the machine and the rotor of the driving electric motor.

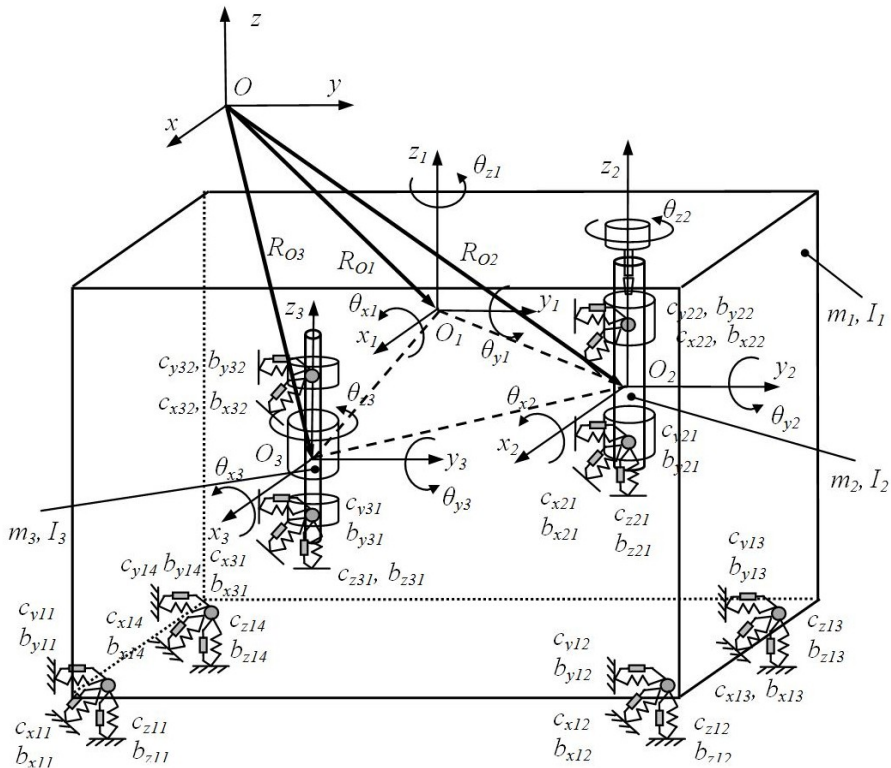

Fig. 6. Mechanic - mathematical model of wood shapers with lower spindle for studying its free damped spatial vibrations

The three bodies of the mechanical system perform spatial vibrations - three small translations and three small rotations relative to the axes of the rectangular local coordinate systems that are fixedly connected to the bodies. It is assumed that the axes of the local coordinate systems are parallel to the axes of the reference coordinate system.

The position of the mechanical system in space is defined by the vector of the generalized coordinates (Fig. 6), which is

$$\mathbf{q} = [x_1 y_1 z_1 \theta_{x1} \theta_{y1} \theta_{z1} x_2 y_2 z_2 \theta_{x2} \theta_{y2} \theta_{z2} x_3 y_3 z_3 \theta_{x3} \theta_{y3} \theta_{z3}]^T \quad (1)$$

The mechanical system has 18 degrees of freedom. The building of its mechanic-mathematical model is presented below.

The matrixes of the transition in small vibrations from the local coordinate systems of the bodies $O_i x_i y_i z_i$ to the reference coordinate system $Oxyz$ have the form

$$\mathbf{A}_i^0 = \begin{bmatrix} 1 & -\theta_{zi} & \theta_{yi} & x_i \\ \theta_{zi} & 1 & -\theta_{xi} & y_i \\ -\theta_{yi} & \theta_{xi} & 1 & z_i \\ 0 & 0 & 0 & 1 \end{bmatrix}, i=1,2,3 \quad (2)$$

The vector of the position of the center of mass of the relevant body, projected in the reference coordinate system, is determined with

$$\mathbf{R}_{Ci}^0 = \mathbf{A}_i^0 \cdot \mathbf{r}_{Ci} = \begin{bmatrix} l_{Cx} + x_i + l_{Cz} \cdot \theta_{yi} - l_{Cy} \cdot \theta_{zi} \\ l_{Cy} + y_i + l_{Cz} \cdot \theta_{xi} - l_{Cx} \cdot \theta_{zi} \\ l_{Cz} + z_i + l_{Cy} \cdot \theta_{xi} - l_{Cx} \cdot \theta_{yi} \\ 1 \end{bmatrix}, i=1,2,3 \quad (3)$$

where $\mathbf{r}_{Ci} = [l_{Cx} \ l_{Cy} \ l_{Cz}]^T$ is the vector of the position of the center of mass in the local coordinate system.

The linear velocity vector of any point Ci of body i , projected in the reference coordinate system, is obtained by differentiating by the time of the position's vector of the same point

$$\mathbf{V}_{Ci}^0 = \frac{d\mathbf{R}_{Ci}^0}{dt} = \begin{bmatrix} \dot{x}_i + l_{Cz} \cdot \dot{\theta}_{yi} - l_{Cy} \cdot \dot{\theta}_{zi} \\ \dot{y}_i + l_{Cz} \cdot \dot{\theta}_{xi} - l_{Cx} \cdot \dot{\theta}_{zi} \\ \dot{z}_i + l_{Cy} \cdot \dot{\theta}_{xi} - l_{Cx} \cdot \dot{\theta}_{yi} \\ 0 \end{bmatrix}, i=1,2,3 \quad (4)$$

The vector of angular velocity of the body i , projected in the local coordinate system, is

$$\mathbf{\Omega}_i^i = \begin{bmatrix} \dot{\theta}_{xi} \\ \dot{\theta}_{yi} \\ \dot{\theta}_{zi} \\ 0 \end{bmatrix}, i=1,2,3 \quad (5)$$

The kinetic energy of the mechanical system is

$$E_K = \sum_{i=1}^3 E_{Ki} \quad (6)$$

where $E_{Ki} = \frac{1}{2} \cdot (m_{RR}^i \cdot V_{Ci}^0 \cdot V_{Ci}^0 + \Omega_i^i \cdot I_{\omega\omega} \cdot \Omega_i^i)$, $\mathbf{m}_{RR}^i = \int_{V_i} \rho_i \cdot \mathbf{I} \cdot dV_i = m_i \cdot I$.

The elements of the matrix M of mass-inertial properties are defined by the expression

$$m_{i,j} = \frac{\partial^2 E_K}{\partial \dot{q}_i \cdot \partial \dot{q}_j} \quad (7)$$

The potential energy is defined by

$$E_P = E_{PK}(q)_m + E_{PG}(q)_i \quad (8)$$

where $E_{PK}(q)_m = \sum_{m=1}^8 \frac{1}{2} \cdot q^T \cdot C(q) \cdot q$, $E_{PG}(q)_i = \sum_{i=1}^3 -m_i \cdot g^T \cdot R_{Ci}^0$,

$C(q)$ is a matrix of elastic properties,

$g = [0 \ 0 \ g \ 0]^T$ – vector of gravitational acceleration,

m – the number of the elastic element between two bodies of the mechanical system.

The differential equations of the free damped spatial vibrations are derived by using the Lagrange's method

$$\frac{d}{dt} \left(\frac{\partial E_K}{\partial \dot{q}} \right) - \left(\frac{\partial E_K}{\partial q} \right) + \frac{\partial F_b}{\partial \dot{q}} + \frac{\partial E_P}{\partial q} = 0 \quad (9)$$

where E_K and E_P are respectively the kinetic and the potential energy of the systems, and F_b is the energy dissipation or dissipative function.

The obtained system of differential equations, which describes the small free damped vibrations of the mechanical system, is

$$M \cdot \ddot{q} + B \cdot \dot{q} + C \cdot q = 0 \quad (10)$$

The matrix in these equations which characterizes the mass-inertial properties of the mechanical system is M, and the elastic properties – $C \cdot B(\dot{q})$ is the matrix that characterizes the damping properties of this system.

$$M = [a_{ij}], \quad a_{ij} = \frac{\partial^2 E_K}{\partial \dot{q}_i \cdot \partial \dot{q}_j}, \quad C = [c_{ij}], \quad c_{ij} = \frac{\partial^2 E_P}{\partial q_i \cdot \partial q_j}$$

The matrix $B = [b_{m,n}]$ is obtained by substituting the elements of the matrix C – $c_{m,n}$ with $b_{m,n}$.

Solutions of the system of the differential equations (10) are searched as

$$q = V \cdot e^{pt} \quad (11)$$

After differentiation of equations (11) and substituting in (10) it is obtained

$$(p^2 \cdot M + p \cdot B + C) V = 0 \quad (12)$$

where V is the matrix of natural vectors (modal matrix).

The matrix of natural vectors (modal matrix) has the form

$$V = [v_{r,j}]_{18 \times 18} \quad (13)$$

where $v_r = [v_{ri}]$, $i = 1, 2, \dots, 18$ is the natural mode vector on the generalized coordinate for r -th natural frequency.

The vibrations are defined by their natural values p_r and their natural vectors u_r , which in their general type are complex conjugate numbers

$$p_r = -\alpha_r \pm i \cdot \beta_r, \quad u_r = v_r \pm i \cdot w_r \quad (14)$$

where $\alpha_r = \sigma_r \cdot \omega_r$, $\beta_r = \omega_r \sqrt{1 - \sigma_r^2}$,

σ_r – relative damping coefficient,

α_r – damping coefficient,

β_r – frequency of free damping vibrations,

w_r – the imaginary part of the natural vector caused by the damping of the system,

v_r , ω_r – mode shapes and natural frequencies of not damping system.

The determination of α_r and w_r from the matrix V and B makes it possible to form this matrix

$$K = (V^T \cdot M \cdot V)^{-1} \cdot (V^T \cdot B \cdot V) = [k_{ik}] \quad (15)$$

The damping coefficients are $\alpha_r = 0.5 k_{rr}$. By using the matrix K is formed the matrix

$$D = [d_{ik}] \begin{cases} d_{ik} = 0, & \text{when } \omega_i^2 = \omega_k^2; \\ d_{ik} = k_{ik} \frac{\omega_k}{(\omega_k^2 - \omega_i^2)}, & \text{when } \omega_i^2 \neq \omega_k^2 \end{cases} \quad (16)$$

The matrix W of the imaginary part of the natural vectors of the damped system is determined by the formulas

$$W = V \cdot D \quad (17)$$

where $D = [d_{ik}]$ is matrix (16); $V = [v_{rk}]$ – matrix (13).

The general solutions of the system of natural values p_r and natural vectors u_r , are derived from the initial conditions of motion. The general solutions of the system of differential equations in matrix form, with initial conditions $t = 0$, $q(0) = q_0$, $\dot{q}(0) = \dot{q}_0$ are

$$q(t) = \sum_{r=1}^{18} \frac{2}{g_r^2 + h_r^2} [G_r \cdot M \cdot \dot{q}(0) + (-\alpha_r \cdot G_r \cdot M + \beta_r \cdot H_r \cdot M + G_r \cdot B) \cdot q(0)] e^{-\alpha_r t} \cdot \cos \beta_r t +$$

$$+ \sum_{r=1}^{18} \frac{2}{g_r^2 + h_r^2} [H_r \cdot M \cdot \dot{q}(0) + (-\alpha_r \cdot H_r \cdot M - \beta_r \cdot G_r \cdot M + H_r \cdot B) \cdot q(0)] e^{-\alpha_r t} \cdot \sin \beta_r t$$

where

$$g_r = -2 \alpha_r (V_r^T \cdot M \cdot V_r - W_r^T \cdot M \cdot W_r) - 4 \beta_r V_r^T \cdot M \cdot W_r + V_r^T \cdot B \cdot V_r - W_r^T \cdot B \cdot W_r;$$

$$h_r = 2 \beta_r (V_r^T \cdot M \cdot V_r - W_r^T \cdot M \cdot W_r) - 4 \alpha_r V_r^T \cdot M \cdot W_r + 2 V_r^T \cdot B \cdot W_r;$$

$$G_r = g_r L_r + h_r R_r; \quad L_r = V_r \cdot V_r^T - W_r \cdot W_r^T;$$

$$H_r = h_r L_r - g_r R_r; \quad R_r = V_r \cdot W_r^T + W_r \cdot V_r^T.$$

Results and discussion

Carrying out numerical investigations of the spatial vibrations of a woodworking shaper with lower spindle requires knowledge of the parameters of its elements. Therefore the three bodies and the whole machine are modeled with software Solid Works. These models are shown respectively in Figures 7, 8, 9 and 10. The mass center of the body 1 coincides with the center of the local coordinate system of the body 1 and the center of the reference coordinate system. The mass center of the body 2 coincides with the center of the local coordinate system of the body 2. The mass center of the body 3 coincides with the center of the local coordinate system of the body 3.

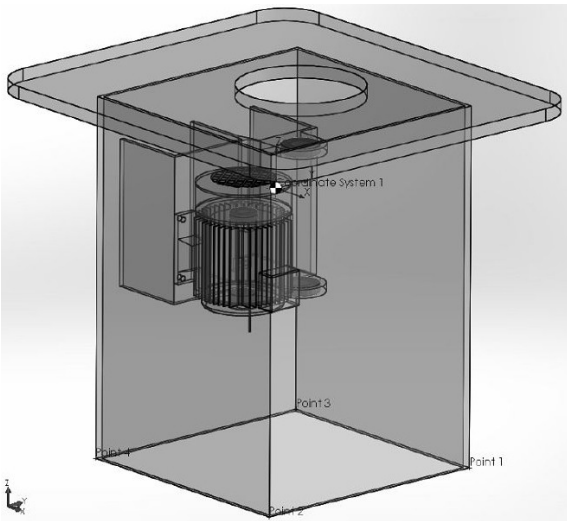

Fig. 7. Body 1

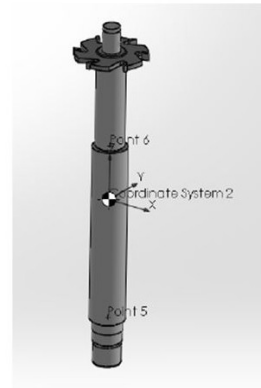

Fig. 8. Body 2

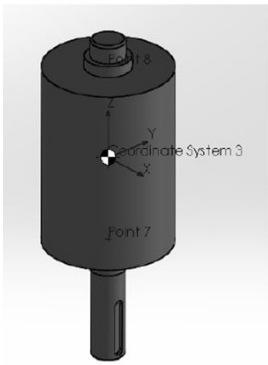

Fig. 9. Body 3

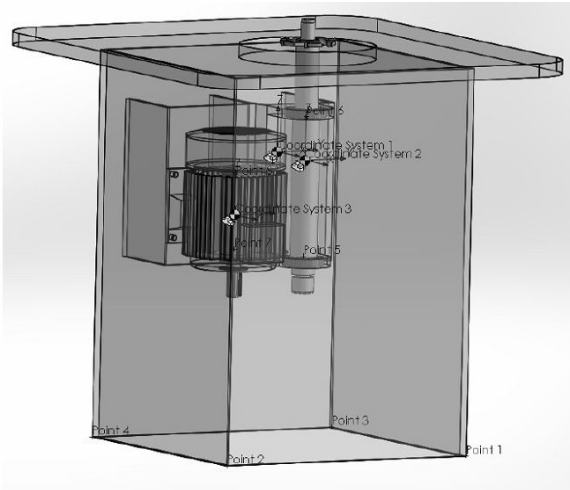

Fig. 10. Woodworking shaper

The presented data of the machine FD-3, which is produced in ZDM – Plovdiv, is used for calculations.

Mass of the bodies: body 1 – $m_1 = 391,52$ kg; body 2 – $m_2 = 11,123$ kg; body 3 – $m_3 = 14,378$ kg.

Tensor of mass inertia moments of the body 1 to the local coordinate system of the body 1, $\text{kg}\cdot\text{m}^2$

$$\mathbf{I}_1 = \begin{bmatrix} 49.2672 & -0.0395 & -0.2525 \\ -0.0395 & 52.0000 & -0.4405 \\ -0.2525 & -0.4405 & 47.9480 \end{bmatrix}$$

Tensor of mass inertia moments of the body 2 to the local coordinate system of the body 2, $\text{kg}\cdot\text{m}^2$

$$\mathbf{I}_2 = \begin{bmatrix} 0.2937 & 0 & 0 \\ 0 & 0.2937 & 0 \\ 0 & 0 & 0.0052 \end{bmatrix}$$

Tensor of mass inertia moments of the body 3 to the local coordinate system of the body 3, $\text{kg}\cdot\text{m}^2$

$$\mathbf{I}_3 = \begin{bmatrix} 0.0516 & 0 & 0 \\ 0 & 0.0516 & 0 \\ 0 & 0 & 0.0206 \end{bmatrix}$$

The coordinates of the mass centers of the bodies are shown in table 1.

Table 1. Coordinates of the centers of mass

| Body No | l_{Cx} , m | l_{Cy} , m | l_{Cz} , m |
|---------|--------------|--------------|--------------|
| 1 | 0 | 0 | 0 |
| 2 | 0.009 | 0.066 | -0.020 |
| 3 | 0.019 | -0.115 | -0.134 |

The coordinates of the supporting points of the elastic elements are shown in tables 2, 3 and 4.

Table 2. Coordinates in the coordinate system of the body 1

| Point | l_{xi} , m | l_{yi} , m | l_{zi} , m |
|-------|--------------|--------------|--------------|
| 1 | 0.309 | 0.316 | -0.654 |
| 2 | 0.309 | -0.284 | -0.654 |
| 3 | -0.291 | 0.316 | -0.654 |
| 4 | -0.291 | -0.284 | -0.654 |
| 5 | 0.009 | 0.066 | -0.234 |
| 6 | 0.009 | 0.066 | 0.076 |
| 7 | 0.019 | -0.015 | -0.210 |
| 8 | 0.019 | -0.015 | -0.050 |

Table 3. Coordinates in the coordinate system of the body 2

| Point | l_{xi} , m | l_{yi} , m | l_{zi} , m |
|-------|--------------|--------------|--------------|
| 5 | 0 | 0 | -0.214 |
| 6 | 0 | 0 | 0.096 |

Table 4. Coordinates in the coordinate system of the body 3

| Point | l_{xi} , m | l_{yi} , m | l_{zi} , m |
|-------|--------------|--------------|--------------|
| 7 | 0 | 0 | -0,076 |
| 8 | 0 | 0 | 0,084 |

The elasticity and damping coefficients are shown in tables 5 and 6.

Table 5. Elasticity coefficients

| Between Bodies | C_{xi} , N/m | C_{yi} , N/m | C_{zi} , N/m |
|----------------|----------------|----------------|----------------|
| 0-1 | 350000 | 350000 | 800000 |
| 1-2 | 2250000 | 2250000 | 2250000 |
| 2-3 | 2250000 | 2250000 | 2250000 |

Table 6. Damping coefficients

| Between Bodies | b_{xi} , (N·s)/m | b_{yi} , (N·s)/m | b_{zi} , (N·s)/m |
|----------------|--------------------|--------------------|--------------------|
| 0-1 | 980 | 670 | 470 |
| 1-2 | 980 | 670 | 470 |
| 2-3 | 980 | 670 | 470 |

The calculations are performed by using a software product Mathematica. The free space vibrations are investigated first. Figure 11 graphically illustrates the calculated natural frequencies [Hz] and mode shapes of free spatial vibrations of the studied mechanical system. Natural frequencies are 120.24 Hz; 120.22 Hz; 119.30 Hz; 119.29 Hz; 102.90 Hz; 90.91Hz; 90.85Hz; 90.48Hz; 82.70 Hz; 82.67 Hz; 22.45 Hz; 21.98 Hz; 13.92 Hz; 11.50 Hz; 4.95 Hz; 4.94 Hz ; 0 Hz; 0 Hz . These values are required for determination of the

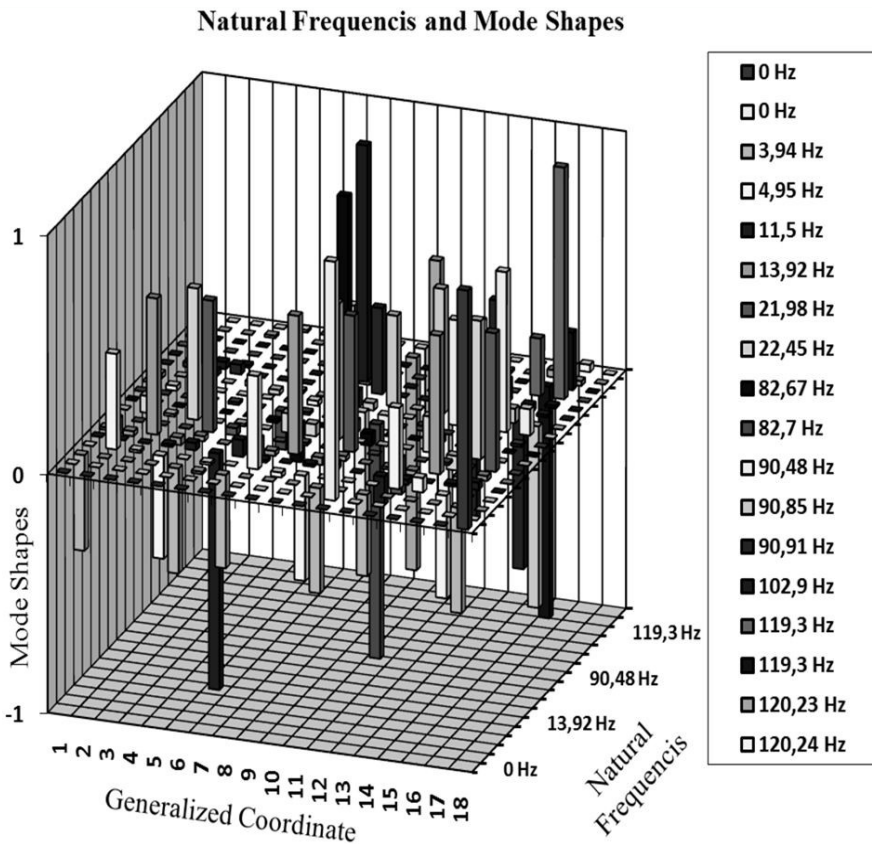
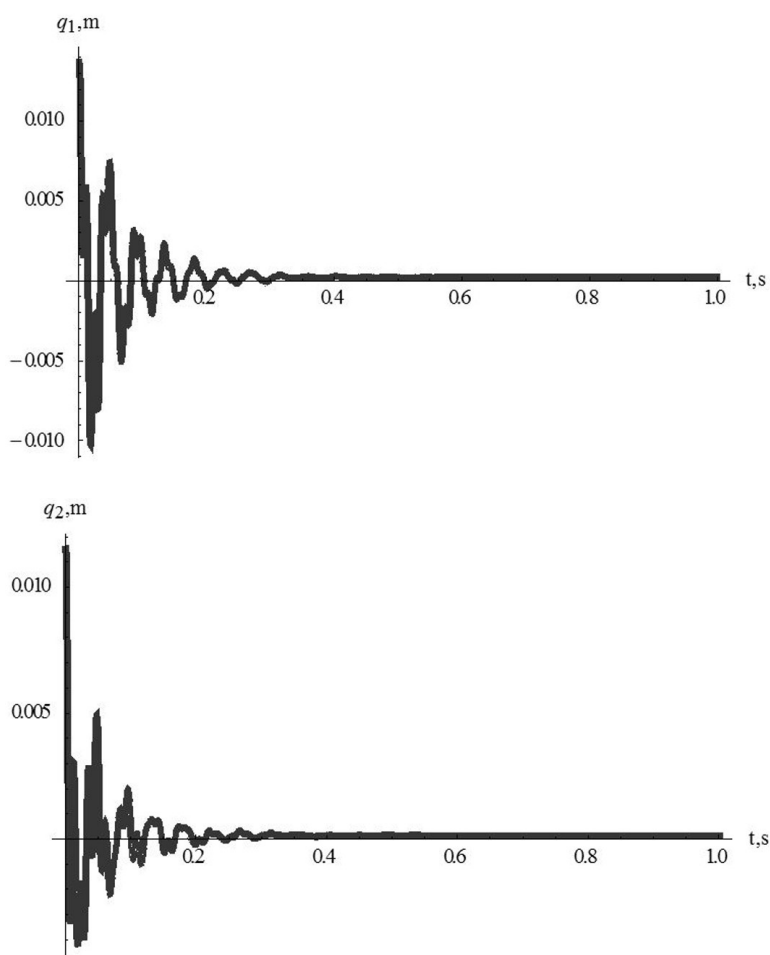
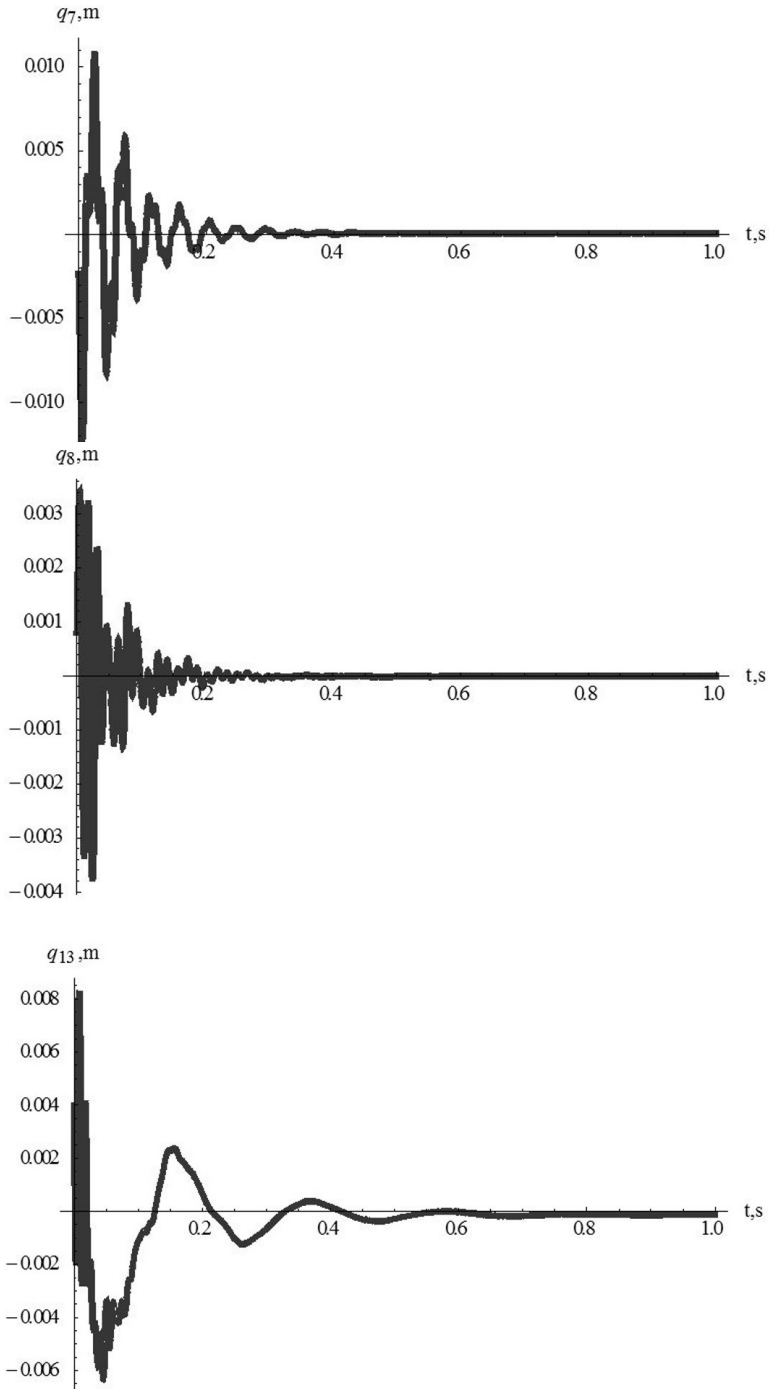

Fig. 11. Natural frequencies [Hz] and mode shapes of the studied mechanical system

resonance zones. The knowledge of the resonance zones allows optimizing working regimes by taking measures to avoid machine operation in these areas or to pass quickly through them. The obtained and illustrated mode shapes are useful for the investigation of the vibration behavior of the machine. Analysis of the received natural frequencies and mode shapes provides an additional opportunity for the formation of reasonable recommendations for the construction of these machines. Then the amplitudes of the free damped vibrations are calculated for the above-mentioned wood shaper. Figure 12 graphically shows the results of the numerical investigations of the free damped vibrations. Just a few of the results are represented here due to the limited place.





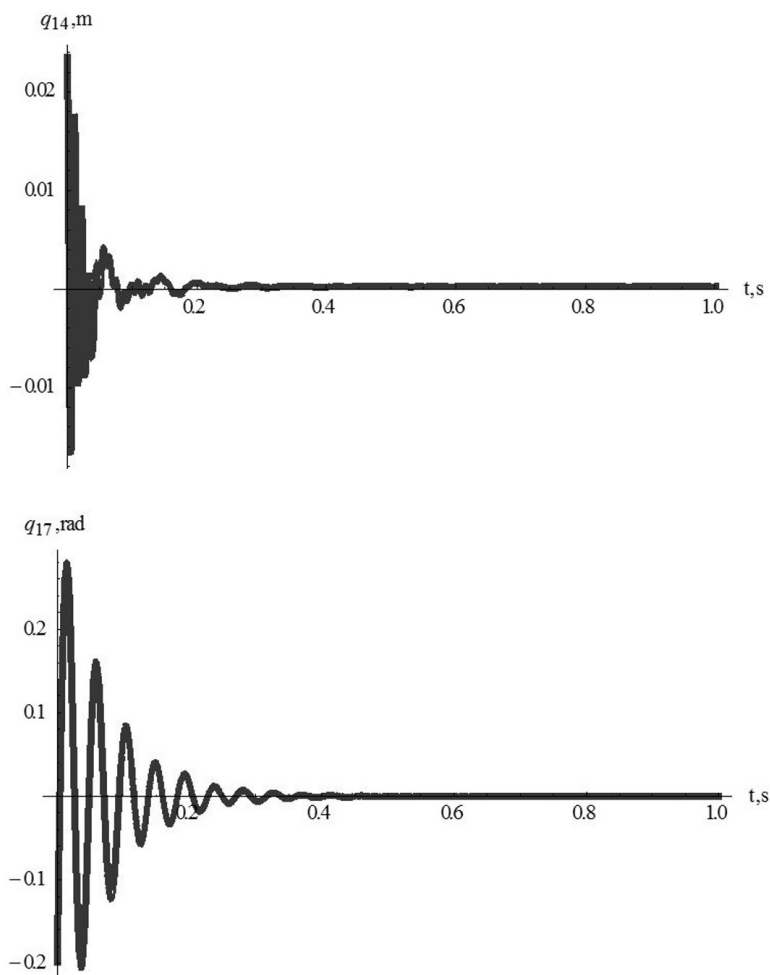

Fig. 12. Results of the investigations

The obtained graphs of the damped vibrations show that at the used coefficients of elasticity and damping all vibrations in the mechanical system get quiet within 1 sec. These coefficients are on a machine in optimal technical condition. The presented model allows modelling and exploration of various technical conditions of this machine and offers possibilities for the practical determination of the current technical state.

Conclusions

The presented study investigates spatial vibrations of a woodworking shaper. The investigations are carried out on the base of an original mechanic-mathematical model of a woodworking shaper, developed by the authors. The

model considers woodworking shapers with lower placement of the spindle. In this model the woodworking shaper, the spindle and the electric motor's rotor are regarded as rigid bodies, which are connected by elastic and damping elements with each other and with the motionless floor. It takes into account the characteristics in the construction of woodworking shapers. The model renders into account the needed mass, inertia, elastic and damping properties of the elements of the considered system. It includes all necessary geometric parameters of this system. Then a compiled system of matrix differential equations is presented and analytical solutions are derived. Numerical calculations are carried out by using the developed model and modern computer programs. The calculations use parameters of a machine, used in practice. As a result of the whole study, the spatial vibrations of the studied mechanical system are obtained and illustrated. The results of the conducted study allow analyzing the influence of the parameters of the elastic and damping elements of the construction on the machine's work. The main goal is to increase the reliability of the machine, as well as the accuracy and quality of the wood articles' processing.

References

- Amirouche F.** [2006]: Fundamentals of multibody dynamics – theory and applications. Birkhauser, Boston
- Angelov I.** [2011]: Matrix mechanics. Dynamics, Avangard Prima, Sofia
- Barcik Š., Kvietková M., Aláč P.** [2011]: Effect of the chosen parameters on deflection angle between cutting sides during the cutting of agglomerated materials by water jet. Wood Research 56 [4]: 577-588
- Beljo-Lučić R., Goglia V.** [2001]: Some possibilities for reducing circular saw idling noise. Journal of Wood Science 47 [5]: 389–393
- Coutinho M.** [2001]: Dynamic simulations of multibody systems. Springer-Verlag, New York
- Filipov G.** [1977]: Woodworking machines. Sofia
- Gochev Z., Vukov G.** [2017]: Influence of the wearing of the saw unit elements of the wood shaper on the system vibration. Acta Facultatis Xylogologiae Zvolen 59 [2]: 147-153
- Gochev Z., Vukov G., Vitchev P., Atanasov V., Kovachev G.** [2017]: Influence of the cutting mode on the overall vibrations generated by the woodworking milling machine. Annals of Warsaw University of Life Science – SGGW, Forestry and Wood Technology 98: 33-42
- Kminiak R., Siklienka M., Šustek J.** [2016]: Impact of tool wear on the quality of the surface in routing of MDF boards by milling machines with reversible blades. Acta Facultatis Xylogologiae Zvolen 58 [2]: 89-100
- Minchev N., Grigorov V.** [1998]: Vibrodiagnostics of rotary and piston machines. Technique, Sofia
- Nikravesh P.** [1988]: Computer-aided analysis of mechanical systems. Prentice Hall, New Jersey
- Obreshkov P.** [1996]: Woodworking machines. Sofia

- Orlowski K., Sandak J., Tanaka C.** [2007]: The critical rotational speed of circular saw: simple measurement method and its practical implementations. *Journal of Wood Science* 53 [5]: 388-393
- Shabana A.** [2005]: *Dynamics of multibody systems*. Cambridge University Press, New York
- Stevens D.** [2007]: *Machinery vibration diagnostics* NGUYEN. Troy
- Veits V., Kochura A., Martinenko A.** [1971]: *Dynamical investigations of drive machines*. Moscow
- Vukov G., Gochev Z., Slavov V.** [2016]: Mechanic-mathematical model for investigations of the free damped spatial vibrations of wood shaper and its spindle. *Proceedings of the IInd International Furniture Congress, Mugla, Turkey, October 13th-15th*: 216-219

Submission date: 12.09.2018

Online publication date: 3.12.2018