

International Symposium on
HYDROACOUSTICS AND ULTRASONICS
EAA Symposium (formerly 13th FASE Symposium)
Gdańsk-Jurata, 12-16 May 1997

**A Measurement of 3-D Water Velocity Components During ROV Tether
Simulations in a Test Tank
Using Hydroacoustic Doppler Velocimeter**

**Leszek Kwapisz (*)
Marek Narewski
Lech A. Rowiński
Cezary Źrodowski**

**Faculty of Ocean Engineering
Technical University of Gdańsk
Narutowicza 11/12 str.
80-952 Gdańsk-Wrzeszcz**

**(*) Institute of Fluid Mechanics
Polish Academy of Science
Fiszera 14 str
80-268 Gdańsk-Wrzeszcz**

ABSTRACT

A computer simulation of ROV tethers performance could be done more precisely if velocity field of water flowing around the tether cable is known. The paper describes operation and performance of the doppler acoustic velocimeter ADVlab. A brief outline of the procedures and related problems with determination of 3-D velocity components in the test tank is described.

INTRODUCTION

Dept. of Underwater Technology conducts research, development and testing of Remotely Operated Vehicles (ROVs) for over 10 years. One of the critical problems influencing the performance and safety of ROV systems is behaviour of power and communication cables linking underwater vehicle and surface support vessel. One of the main tasks of our project was a development of the computer simulation programme for ROV tethers in 3-D water flow. The programme role is to simulate behaviour of the ROV tethers for certain border conditions in the most reliable way. In

order to verify the results of the computer simulations a set of tests with tether samples and real umbilicals was planned to be carried out in the laboratory and real sea conditions.

The experimental part of the research is being conducted in a special hollow-conical shape tank where a 3-D water flow is created. The desired water flow is generated by a flat rotating disc and is controlled by a variable speed electric AC motor controller. The basic problem in the research was a precise determination of matrix of the 3-D velocity components of water flow in the test tank. This task was performed in the selected part of the tank

used for measurements of geometry and forces induced in the cable by hydrodynamic phenomena. The measurements were performed using a new generation computer controlled doppler velocimeter - ADVlab manufactured by SONTEK.

TEST STAND DESCRIPTION

All laboratory experiments were completed in the test tank built in the Dept. of Underwater Technology. The old mould was used to build the test tank with diameter of 4m and depth 2m as this was found to be feasible for the planned research after some additional preparations. On the top of the tank there is a long 1m wide platform for laboratory personnel

A 3-D water flow is generated by a bottom located rotating disc agitator. The disc is propelled by a vertical shaft by AC electric

motor mounted under tank platform. With application of Eurotherm Drives 584S 2.2 kW inverter a stepless speed control is available. One of the problems encountered was a generation of the 3-D water velocity field which is stable and vertical secondary flow stream induced by centrifugal forces is minimal. For this purpose a large diameter (1.8m) flat disc was designed and was found to be simple and cheap solution. The flat disc agitator performs very well and could move all water into circular motion quite quickly.

A single Aluminium alloy shape rail with angle scale is fitted on the half of the top tank edge. The rail supports two light and stiff horizontally panning arms. The arms outer end glides on the rail while the second is fitted in the tank centre. The horizontally placed arms and vertical, stiff pole allow for a placement of the ADVlab probe in every point of measurement area.

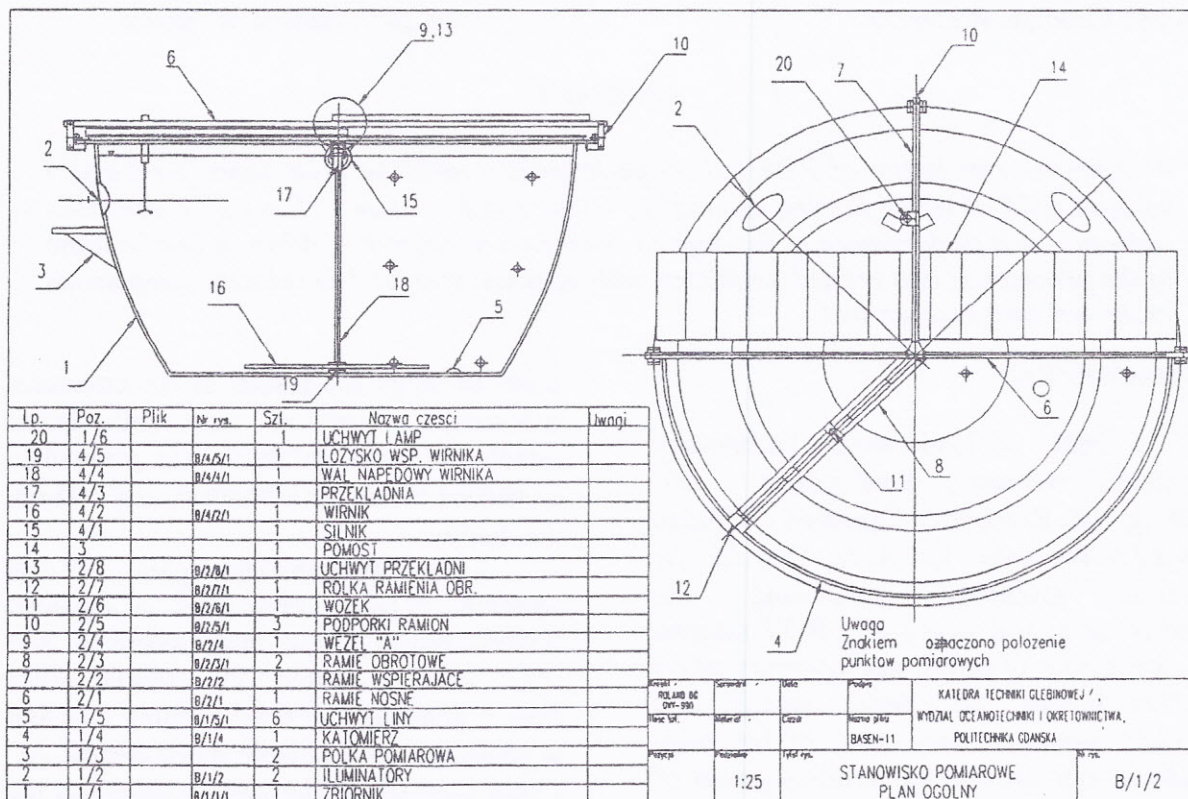

Fig.1. The test stand

The geometrical characteristics (XYZ coordinates) of the tether is completed using video stereovision measurement system consisting of two identical and calibrated monochromatic, high light sensitive CCD cameras. The measurement area is located in a front of two hemispherical camera viewports and totally covers about 1/3 of the test tank volume. The viewports are located in 120° azimuth angle. (Fig 2). The

angle between optic axis of the camera lenses could vary between 60-120° and this solution allows for possibly optimal choice of the observation angle and minimal position errors. The picture is recorded on S-VHS recorder and next is analysed using PCX/PCXi computer image analysing card and software.

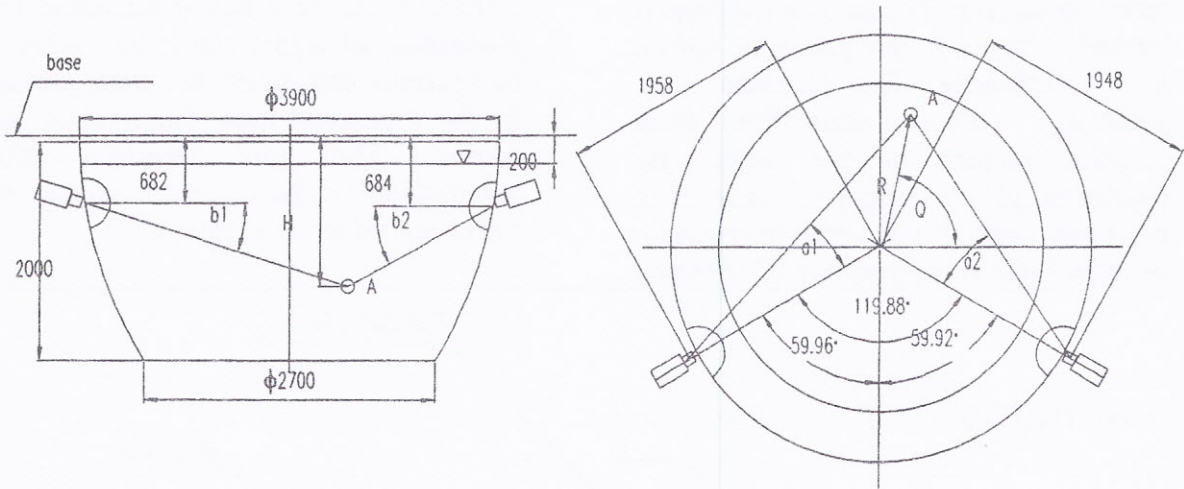

Fig.2. The geometry of measurement system

DETERMINATION OF WATER VELOCITY VECTOR

An important factor for further analytical data comparison is real value of velocity vector and its components (V_x , V_y , V_z). For the purpose of velocity matrix determination the co-ordinates net is superimposed onto the tank measurement space where unit steps are as follows: $\Delta\theta = 5$ grad, $r = 20$ cm, $h = 20$ cm and in close distance to the tank axis step is 10 grad. Thus we have about 1000 nodes in the measurement space. In the next step the measurement of 3-D water velocity vector is done in the nodes of measurement space. The resultant velocity matrix is a basement for calculations of tethers characteristics by a verified software. The

problem was identified in the beginning of the project and we started to look intensively for an instrument feasible for easy and reliable measurement of 3-D velocity vector components in selected points of water test tank. A highly recommended by some researchers and having good references the remote sensing 3-D velocity sensor ADVlab was selected for the research.

ADVlab used for velocity measurements is 3-D Acoustic Doppler Velocimeter ADVlab made by SONTEK. The advantage of this instrument is that it is inherently drift-free and does not require routine calibration. Also acoustic signals do not suffer the range limitations of optical

pulses in turbid waters. The instrument consists of three main parts:

1. Sensor head (probe) which consists of a 10 MHz transmitter and 2 or 3 - 10 MHz receivers positioned in 120 ° increments on a circle around transmitter. Transmitter generates a very narrow acoustic beam 6-7 mm wide. The probe is submerged in the flow and the receivers are slanted at 30° from the axis of the transmit transducer and focus on common sampling volume. The sampling volume is located 5cm from the probe to reduce flow interference. The receivers are gathering reflected echo from small particles present in the water. By regulation of the length of transmitted pulse and position and width of receiving window there is a possibility of changing

dimensions and position of the sampling volume. For a typical sensor it has 9 mm height and its centre is located 50 mm from the transducer.

2. Conditioning module - analog electronic boards which are located in a waterproof housing close to the transducer/receiver probe. The task of the board is filtering and amplifying signals and transmitting them for further processing.

3. Digital computer card is manufactured in a IBM/PC standard and is dedicated for processing all signals into 3-D velocity components data using all data specific for the instrument used, temperature and salinity. The card provides also visualisation on the computer screen all calculated values in a real time.

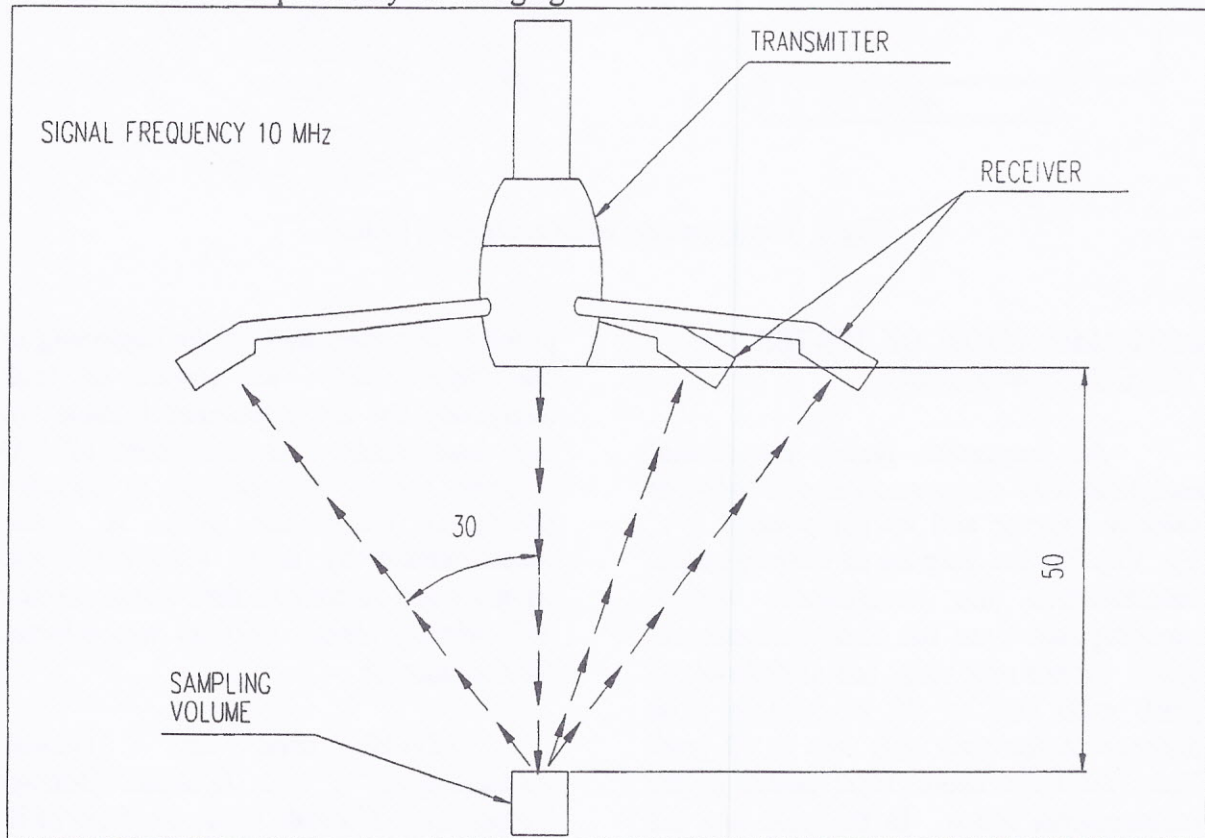

Fig.3. Principle of operation of ADV

The selection of ADVlab was done after analysis of almost all types of velocimeters available on the market. The major advantages of ADVlab are:

1. Very small measurement volume (cylinder 6-7mm in diameter and height in the range 3-20mm. In some non std probes

this volume could even be smaller up to 0.6mm.

2. The measurements are made in a distance of 5 cm from transducing/receiving element thus the probe do not interfere with a flow.
3. The probe could measure a distance between probe and the border of the medium what is possible due to precise location in his proximity i.e. during measurements of the border layers.
4. High precision 1%
5. Very high resolution 0.1 mm/s
6. Broad range of velocities from 0-up to 2.5 m/s and linearity in the whole range (0.25%) and good results in case of speeds around 0.
7. The frequency of the measurements is software controlled from 0 to 25 Hz and small measurement volume allows for turbulence research.
8. Simultaneous measurement and visualisation of 3 velocity vector components is done in a real time
9. Measurement of the difference of noise levels between velocity signal and noise allows for a quick estimation of the results quality (for frequency of 25Hz it is advice S/NR=15dB)
10. High durability and lack of moving and needing any replacement parts.
11. Calibration of the instrument is done in a factory and there is no need for any additional calibration until the mechanical destruction or dimensional changes of the probe. The changes of water characteristics is software controlled.
12. All calculated velocity data are presented in a real time and all instrument diagnostics is done automatically.
13. Modest host system requirements (PC386/387 ISA)
14. Long interconnecting cables up to 30m linking probe and the PC card what is very feasible for field measurements.
15. Possibility of interchanging the probes for non std measurements (side 2 and 3-axis)

The drawbacks of the ADVlab instrument include:

1. For the best results there must be some seeding material used (optimal 10-50g/m³) where the size of the particles must be at least 10µm. In the case of our research seeding material decreased water transparency and lowered the conditions for tv observations of the cables shape. The seeding material tends to lay on the bottom and after some longer time breaks a new portion of seeding material must be added.
2. All data are recorded in a compressed format and further analysis requires time consuming unpacking procedures.
3. In certain cases there could be a problem with free slot in the host computer.
4. The presence of „quite large” electronic housing (50x300mm) with analog part of the instrument not far from the probe (400mm) could affect some measurements.

SUMMARY

A sample plot of the circumferential velocity (V_x) component is shown in the Fig. 4. As it is clearly visible this component is constant for all measurement area. However we can notice some fluctuations in the vertical tank axis area. The velocities of the other components (radial and vertical) are significantly lower and we assume that they do not have influence on the shape and other data of the tested cable.

The selected equipment appeared to be precise and reliable. All the measured velocity data are comparable with those obtained by more costly laser systems [3]. The cost of acoustic doppler instrument ADVlab and comparable laser system is like 1:10. Hydracoustic Doppler instrument do not require any calibration and could be used in almost every conditions. Moreover the up t 4-8 ADV could be used simultaneously and be operated by 1-2 host computers. This could be promising for application in other research projects.

ACKNOWLEDGMENTS

The tests described in this paper were financially supported by Polish Scientific

Research Committee (KBN) grant no 9T12 03308. In completion of the grant there was also used experience and instrumentation gained during research project no 9 S604 04004 financed by KBN.

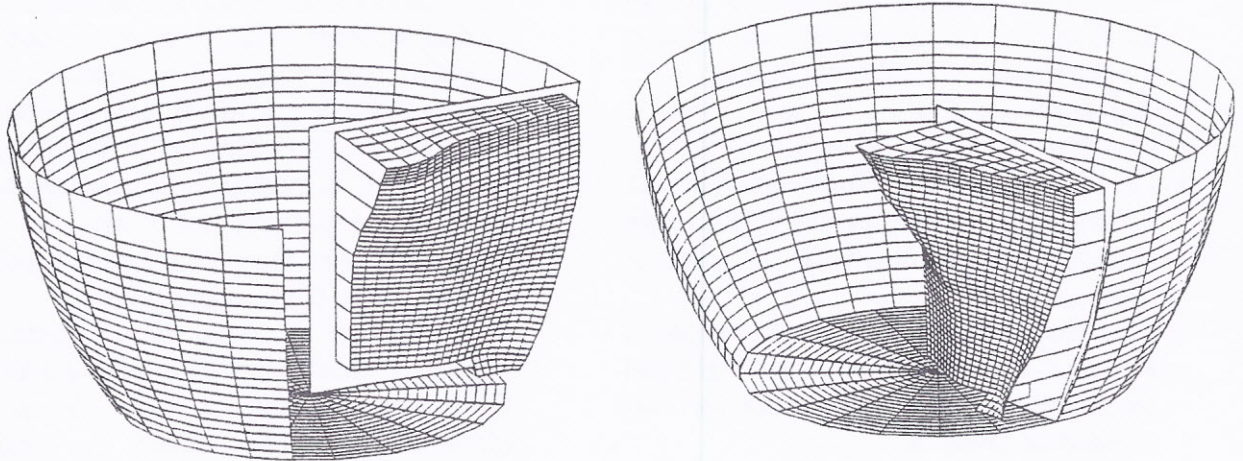

Fig.4. The plot of the circumferential velocity (V_x) component

BIBLIOGRAPHY

1. **Hover, Grosenbaugh, Triantafyllou** : Modelling the dynamics of Deeply Towed Underwater vehicle; Proc. of European Offshore Mechanics Symposium, The Int. Society of Polar Engineers, 1990
2. **Lathman S.**; Predictions of Tether Drag for Mine Hunting ROVs, Proc. of ROVs'90 Conference and Exhibition, Marine Technology Society, San Diego 1990
3. **Lohrman A., Cabrera R.**; Acoustic Doppler Velocimeter for laboratory Use; Proc. Fundamentals and Advancements in Hydraulic Measurement and Experimentation, Buffalo, New York, 1994
4. **Lohrman A., Cabrera R.**; Direct Measurement of Reynolds Stress with an Acoustic Doppler Velocimeter, Proceedings of IEEE 5th Working Conference on Current Measurement, 1995
5. **Narewski M., Pyszko R. Łukaszewicz D., Rowiński L.A.**: Ocena możliwości zastosowania kart graficznych i metod analizy obrazu do usprawnienia procesu sterowania zdalnego urządzeniami do wykonywania prac podwodnych; Oprac. WOiO nr 96/94. Spraw. z grantu KBN nr (S604 040 04, Gdańsk 1994
6. **SONTEK**, ADVlab Operation Manual, San Diego, 1995