

**Jerzy BAJKOWSKI**

Warsaw University of Technology  
Faculty of Automotive and Construction  
Machinery Engineering  
jba@simr.pw.edu.pl

## OPERATIONAL CHARACTERISTICS OF ROTATING MAGNETOREOLOGICAL CLUTCHES AND BRAKES

---

**Key words:** magnetorheological fluids, smart materials, clutch, brake, torque, temperature.

**Abstract:** The following article is devoted to research on particular operational characteristics of prototypes of rotating magnetorheological clutches and brakes. The experiments were conducted on a specialized test stand, including a high power servo-motor, torque meters, and thermal sensors. In addition to the generally determined relationship of the clutch or brake torque transmitted over time and depending on the electric current, it has been shown that the particular operational characteristics of these devices are necessary for the full operational picture of the performance of the device. These are, among others, the torque versus rotational speed, temperature, and operational time dependencies.

---

### Wybrane charakterystyki obrotowych sprzęgieł i hamulców magnetoreologicznych

**Słowa kluczowe:** płyny magnetoreologiczne, materiały inteligentne, sprzęgło, hamulec, moment obrotowy, temperatura.

**Streszczenie:** Praca poświęcona jest badaniom prototypów sprzęgieł i hamulców magnetoreologicznych pracujących w ruchu obrotowym. Zostały one przeprowadzone na specjalistycznym stanowisku badawczym. Obok powszechnie wyznaczonych zależności przenoszonego momentu obrotowego sprzęgła lub hamulca w funkcji czasu i w zależności od wartości natężenia prądu płynącego w solenoidach tych urządzeń i sterującego natężeniem pola magnetycznego wytwarzanego wokół cieczy magnetoreologicznej wykazano, że do pełnego obrazu eksploatacyjnych warunków pracy niezbędne jest wyznaczenie dodatkowych charakterystyk tych urządzeń. Są nimi między innymi wyznaczane w pracy charakterystyki ilustrujące zależności momentu obrotowego w funkcji obrotów, temperatury i inne.

---

### Introduction

Magnetically controlled liquids belong to group of smart materials, whose properties as recently explored in a number of scientific papers, as well as practical applications. They were already applied in various types of technical equipment like heavy-duty construction machines, robotics, household appliances, and surface machining. The increased of interest for this group of materials was caused by the development of the shock-absorbing automobile system called “Magne Ride,” which has been produced since 2000. Some other magnetically controlled-components were introduced, like controlled

elastomers supporting the engine or gearbox. In the group of materials controlled by magnetic field intensity, electro- and magnetorheological (MR) fluids were used at the earliest. The operation of devices such as dampers, shock absorbers, and couplings are based on the properties of magnetorheological fluids (MRF). They are characterized by a non-linear dependence of changes in the values of tangential stress as a function of shear rate. The properties of colloidal suspension of particles in the carrier fluid depend on their shape, size, and type of dispersed material, as well as the deformability and particle concentration. The properties of fluids are determined by the magnitude

of the magnetic field, due to the fact that the dispersed particles are ferromagnetic carbonyl iron.

Although the clutch was the first patented device using MRF, the rotating devices are much less popular than linear operating devices. Despite the prototype constructions for research purposes, the well-known and commercially available rotating device is the Lord's RD-8058-1 TFD Steer-by-Wire variable resistive steering torque device. The characteristics of MR rotary devices used in special constructions, such as the suspension of transport vehicles, tanks, etc. are not publicly available. The following article presents original results on the particular operation characteristics of the rotational MR clutch.

## 1. Research purpose

This paper presents the results of research on prototype, rotary magnetorheological clutches, and brakes, which were designed and manufactured at the Institute of Machine Design Fundamentals of the Warsaw University of Technology. Their final design was completed with accordance to a number of theoretical and simulation analysis, modelling, and laboratory tests performed on pre-assembled prototypes. Figure 1 presents the general construction scheme of a rotating MR device and the final construction of the rotating prototype clutch. Figures 2 and 3 show the configurations of the laboratory stand with a clutch and MR brake. The MR brake was used to control the load applied to the output shaft of the clutch. The

shear stress of the liquid in the narrow gap is controlled by the changes in the magnetic field. The magnetic field intensity can be changed by adjusting the current in the coil's winding.

Although the clutch and brake share a similar housing, their constructional solutions are distinct due to different operation type and work regime. For the rotary magnetorheological damper or brake, it is either a rotor moving relatively to the fixed housing, or a stationary housing moving relatively to the fixed rotor. The clutch usually requires frequent switching on and off, while transferring larger torque between two rotating shafts, and operating with a long-term slip. The design of the brake is usually less complicated than the design of the clutch, since the magnetic circuit is simplified. It is especially important in to choose the proper construction of the device that provides fair heat transfer, preventing the MR fluid from exceeding the maximum operating temperature, which influences the performance of the device, which will be showed in the following results.

The main aim of the research was to determine particular operational characteristics of the MR and brake, which are important for real-life applications. Parameters that were recorded were torque, rotational speed, temperature, exploitation time, and electric current in the coil of the devices. The research methodology for both the clutch and brake was carried out according to a similar procedure. All of the experimental results presented below were performed on a custom designed test bench in two configurations (Figures 2 and 3).

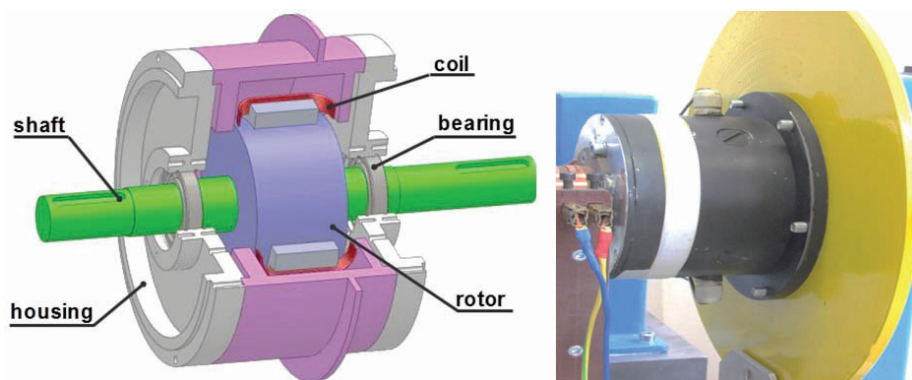

Fig. 1. Construction scheme of the rotating magnetorheological device and photo of the final design of the prototype magnetorheological clutch

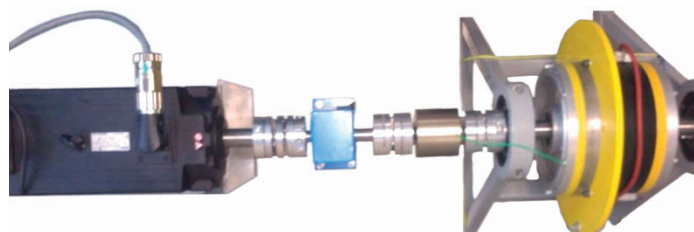

Fig. 2. Configuration of the test bench for magnetorheological brake testing

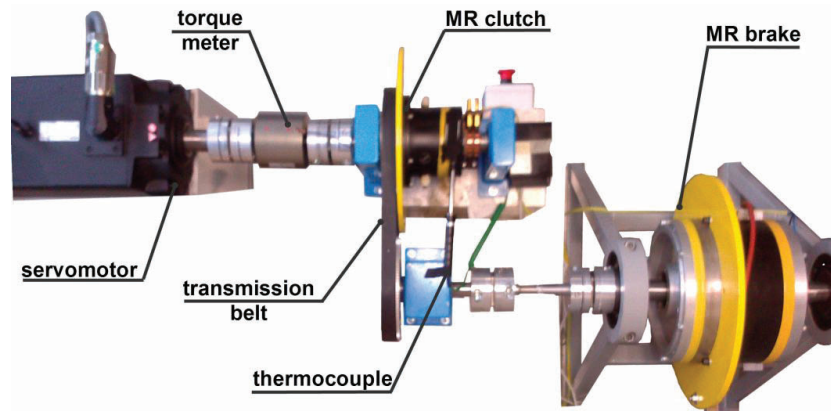

Fig. 3. Configuration of the test bench for magnetorheological clutch testing

The laboratory stand allowed the study of the clutch-break configuration as a torque transmission system. The experiments were conducted using high-accuracy measuring devices: torque sensors, thermocouple sensors, thermal camera, programmable power supply, frequency inverter, and data acquisition system. The main shaft was driven by the electric servo motor of 20 kW power. The electric current was controlled by the stabilized, programmable, laboratory power supply.

## 2. Characteristics of magnetorheological clutch

### 2.1. Clutch and brake torque transmitted at low rotational speed

Initially, the measurements of torque transmitted by the clutch were obtained for a low rotating speed (3 rpm) of the main shaft. The results presented in Figure 4 were obtained for electric currents ranging from  $i = 0$  to 4.0 A. Each of the characteristics shows the mean value of torque over time for five repetitions of the measurement, conducted under repetitive conditions.

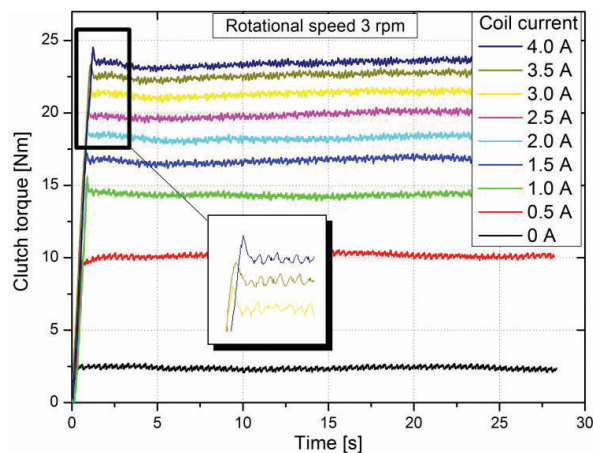

Fig. 4. Torque transmitted by the clutch for different electric currents at a low speed of 3 rpm

When the electric current value is 0, the initially recorded torque peak reaches 3 Nm and stabilizes at 2.5 Nm. The peak resented as the zoomed area in Fig. 4 is caused by the static friction of the parts and the magnetic remanence of the MR fluid. After the device starts rotating, the torque value decreases and stabilizes. When the electric current is increased, higher torque values can be transmitted by the clutch. For 0.5 A the maximum transmitted torque is increased to 10 Nm, while for 2.5 A the maximum torque reaches almost 20 Nm. When the coil current is further increased, the magnetization of the MR fluid reaches saturation. As the total magnetic flux density levels off, so does the transmitted torque. Moreover, when the device operates with higher electric currents, the coil is heating faster, and thus the increased temperature negatively influences the viscous characteristic of the fluid.

The same procedure as for the MR clutch was used to obtain characteristic for MR brake. The housing of the brake was fixed, while the shaft was driven by the servomotor. When different coil currents were applied, the brake resisted the servomotor with a different braking torque. The torque was measured by the dedicated torque meter, as well as temperature of the device's housing. Figure 5 illustrates the mean values of braking torque, recorded at a low rotation speed of 3 rpm.

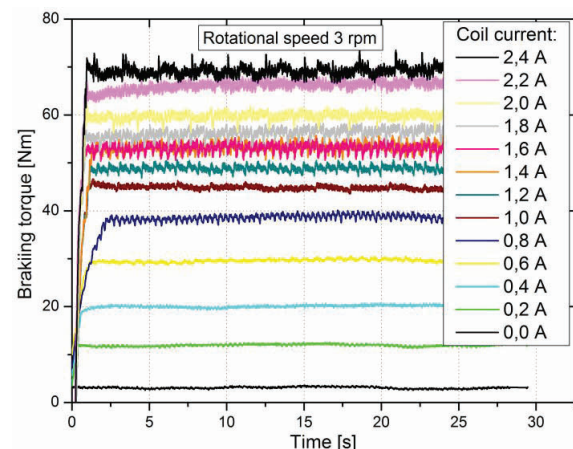

Fig. 5. Braking torque for different electric currents at a low rotational speed of 3 rpm

Characteristics obtained for zero magnetic field (0 A) indicate that the value of the braking torque is the highest during the initial rotations due to static frictional forces and magnetic remanence in the fluid, causing higher initial shear stress. The value of braking torque stabilizes during the measurement cycle at about 3 Nm. For 0.2 A, the braking torque reaches 12 Nm, and for 0.4 A this value is increased up to 20 Nm. Increasing the current in the solenoids to 2.4 A resulted in an increase in the braking torque value to almost 70 Nm. A further increase of the current to 2.6 A practically causes no change in the value of the braking torque, because magnetic saturation of the fluid is reached, which was observed for the MR clutch as well.

## 2.2. Clutch and brake torque and temperature for high rotational speed

In the presented test, the clutch was rotated with speed of revolution from 0 up to 1420 rpm. Because of the viscosity of the MR fluid, as the shear rate of the fluid is higher for higher shear rates, a higher torque value is obtained. The transmitted torque presented in Figure 6 was recorded for different electric current values. The curves reproduce the mean values obtained from the five repetitions of measurements made under identical measuring conditions. The main problem was to limit the heating of the device, to obtain reliable torque vs. speed characteristics, not influence by the temperature. The device was externally cooled with a fan, and the increase of the speed from 0 to 1420 rpm was performed in 30 seconds of operation.

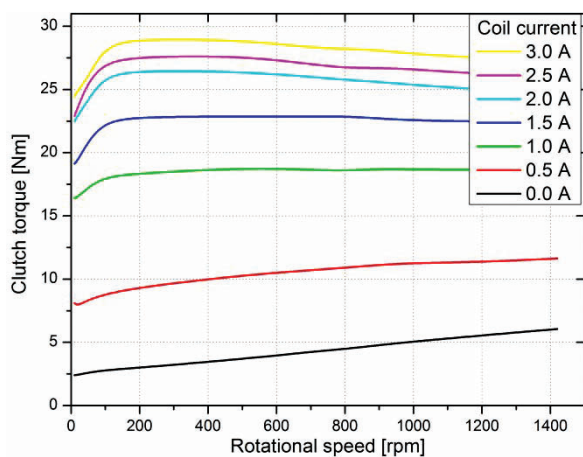

Fig. 6. Torque transmitted by the clutch for different electric currents at high rotational speeds

For 0, 0.5, and 1.0 A, the torque increases in the whole range of the rotation speed (0–1420 rpm). For 0 A, the torque value raises from 2.3 Nm at 3 rpm to 5.7 Nm for 1420 rpm. The recorded increase of the housing temperature was  $\Delta T = 5.8^\circ\text{C}$ . For 0.5 A, the initial torque 7.8 Nm increases to 12.3 Nm for 1420 rpm. The temperature of the housing was increased by

$\Delta T = 7.2^\circ\text{C}$ . The nature of the remaining characteristics for 1.5–3.0 A presented in Figure 5 is different, since the torque increases only up to 200 rpm, and then stabilization or a decrease can be noted. When the clutch is operating at a current value of  $i = 1.0$  A and  $i = 1.5$  A, after reaching maximum transmitted torque, the value is stabilized. Across the variation of the rotational speed, the average increase in temperature was about  $\Delta T = 8^\circ\text{C}$ . In three successive cases (2.0, 2.5, and 3.0 A), after the maximum torque is reached, a slight decrease in torque is observed. The difference in maximum torques and its readings at the highest rotational speed for different currents range from about 1.5 Nm to 3.5 Nm. The average observed increase in temperature in these cases was approximately  $\Delta T = 9^\circ\text{C}$ . A higher speed of revolution should result in a higher value of torque transmitted, due to the increased shear rate. The heating of the fluid inside the device weakens this effect. The servomotor overcomes the frictional forces and shear stresses in the MR fluid, causing increased temperature, and affecting the viscosity parameters of the MR fluid, and as a consequence, the value of transmitted torque is decreased. One should notice that the thermocouple measures the temperature of the housing, not the actual temperature of the fluid, which is much higher.

Brake torque characteristics, as a function of the shaft rotational speed, are illustrated in Figure 7. The brake was externally cooled, due to the quick heating of the activated brake rotated by the heavy-duty servomotor. The increase in the speed from 0 to 1420 rpm was performed in 30 seconds of operation.

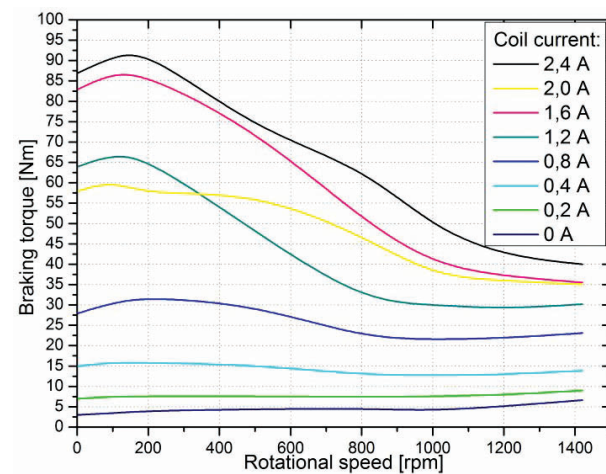

Fig. 7. Braking torque for different electric currents at high rotational speeds

After initially reaching the maximum braking torque, the high rotational speed of the rotor being resisted by the MR fluid causes large heat emission and temperature rise when electric current above 0.8 A is applied. A noticeable decrease of the braking ability is noted. This is directly related to the operational regime of the brake and the measurement procedure. For the test of



the brake, the housing of the device was fixed. The shaft of the brake was rotated by a high-power servomotor. The brake objective was to slow down the shaft, so it was constantly turned on, while the servomotor was trying to maintain constant speed of rotation. This work regime causes very quick heating of the device, and thus the heating causes the noticeable decrease in the torque. So actually, it is not the rotational speed which causes the decrease of the torque, but the temperature rise, which is caused by the operation regime.

### 2.3. Clutch temperature over time of operation

The variations of the temperature of the clutch rotating with constant speed of 500 rpm and 1420 rpm are presented in Figures 8a and b, respectively. For higher rotational speeds, the temperature rise is faster, and over a 120 s time span of continuous operation, the temperature of the housing for 1.0 A is increased to 31°C for 500 rpm, and over 50°C for 1420 rpm. The increased temperature is the result of the heat emitted by the shear fluid and heat emitted by the coils itself, presented in Fig. 9.

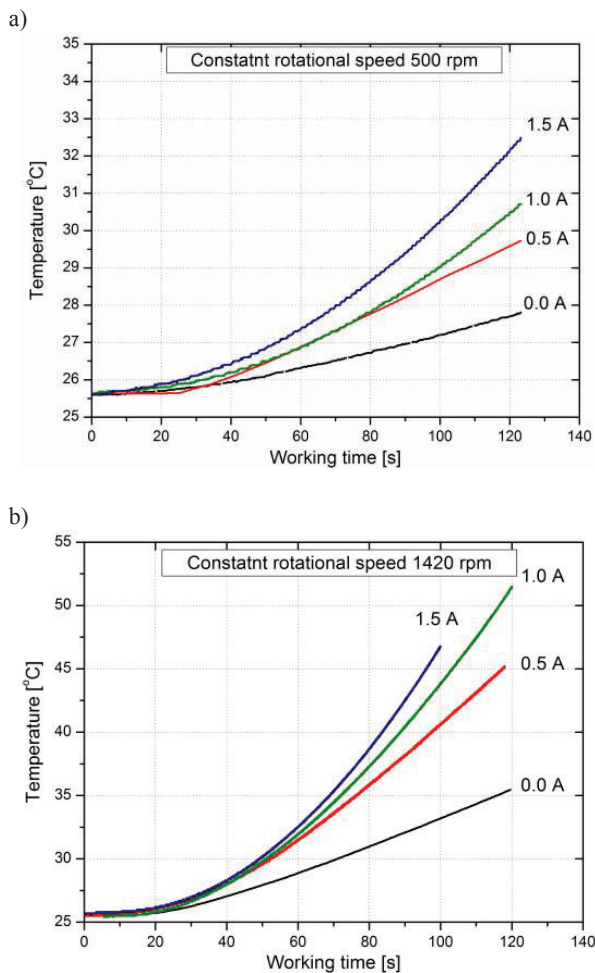

Fig. 8. Temperature of the clutch housing for different values of electric current at constant rotational speeds: a)  $n = 500$  rpm and b) 1420 rpm

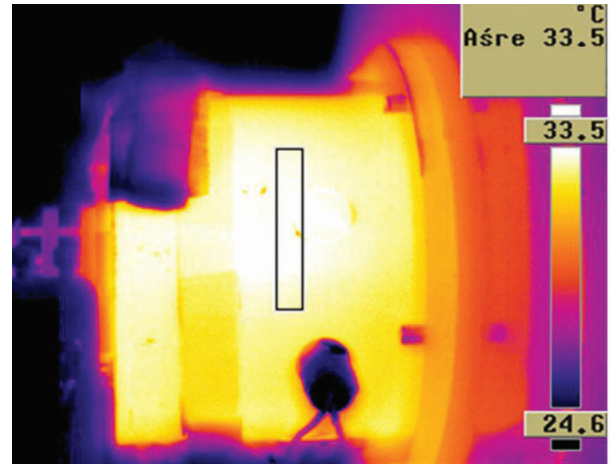

Fig. 9. Thermo-camera measurement of the temperature of the clutch housing

Figure 10 shows how the temperature influences the value of torque transmitted by the clutch over the operational time. Due to the limited space, only the representative results for 1.5 A are presented, yet the curves for other values of electric currents and braking device were similar.

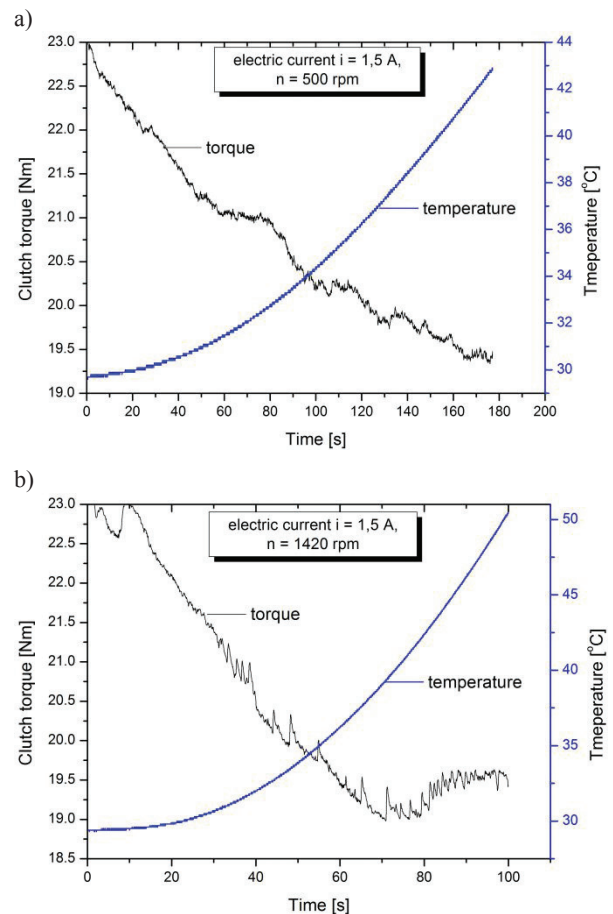

Fig. 10. Clutch torque compared to temperature for different electric currents at constant rotational speeds: a) 500 rpm and b) 1420 rpm

The characteristics were recorded at fixed rotational speeds of 500 and 1420 rpm, so only temperature influenced the results. The decrease of the torque value is associated with the temperature rise. Depending on the value of the current flowing in the solenoid, the corresponding values obtained for 1420 rpm are 5% to 50% higher than values determined at 500 rpm.

---

## Conclusions

---

The dependency between the coil current of the MR device and the torque value for all configurations of the system was extensively examined. Different operating regimes were taken into consideration. When the shaft's speed increases, the temperature of the MR fluid increases, as a consequence of the disintegration of the MR fluid particle chains formed in the magnetic gap. This effect reduces the value of the yield point of the MR fluid and thus the efficiency of the device noticeably declines. The temperature was measured on the surface of the devices. In order to examine the temperature, it would be better to record the temperature of the MR fluid inside the gap of the device. That type of measurement would require using a thermocouple sensor placed inside the housing. The collected material may help to improve the design of the MR brakes and clutches and to increase the efficiency of such devices.

---

## References

---

1. Bajkowski J.: Ciecze i tłumiki magnetoreologiczne. Właściwości, modelowanie, budowa, badania i zastosowania. Wydawnictwa Komunikacji i Łączności Warszawa 2014.
2. Bajkowski J.: Modelowanie, analiza dynamiczna i termiczna prototypu sprzęgła magnetoreologicznego. Zeszyty Naukowe Politechniki Śląskiej Z. 83, s. 210. 2014.
3. Bajkowski J.: Budowa i badania hamulca magnetoreologicznego ze zminimalizowanym magnetyzmem szczątkowym. XXVII Konferencja Naukowa Problemy Rozwoju Maszyn Roboczych. Zakopane, 26–30.01.2014.
4. Bajkowski J., Bajkowski J.M.: Influence of Temperature and Rotational Speed on the Properties of Magnetorheological Brake. *Springer Verlag* ISSN 2195-4356 SPRINGER VERLAG Heidelberg ISBN 978-3-642-37142-4 Pg. 143-149; 978-3-642-37143-1, DOI 101007/978-3-642-37143-1\_18.
5. Bajkowski J.M.: Budowa modelu numerycznego amortyzatora magnetoreologicznego na podstawie badań eksperymentalnych. Praca mgr. PW. Wyd. Mechatroniki 2010.
6. Milecki A.: Ciecze elektro- i magnetoreologiczne oraz ich zastosowania w technice. Wyd. PP., 2010.
7. Skalski P., Bajkowski J., Woznica K.: Comportement du fluide magnetorheologique application au modele viscoplastique de Bodner-Partom. 19-eme Congres Francaise de Mecanique. Marseille 2009.
8. Zalewski R., Nachman J., Shillor M., Bajkowski J.: Dynamic Model for a Magnetorheological Damper: Applied Mathematical Modelling 2014. Vol. 38 Issue: 910, s. 23662376 DOI:http://dx.doi.org/10.1016/j.apm. 2013.10.050.
9. Opracowanie prototypów aktywnych sprzęgieł i tłumików magnetoreologicznych o zerowym magnetyźmie szczątkowym – modelowanie, analiza dynamiczna, termiczna i magnetyczna oraz badania prototypów. Sprawozdanie z projektu badawczego nr Nr R03 0111 10. 2012 (Politechnika Warszawska SiMR).