

NEW DESIGN OF THE FIVE-STROKE SI ENGINE

Marcin Noga, Bronislaw Sendyka

*Cracow University of Technology, Institute of Automobiles and Internal Combustion Engines
Jana Pawła II Av. 37, 31-864 Kraków, Poland
tel.: +48 12 6283688, fax: +48 12 6283690
e-mail: noga@pk.edu.pl, bsendyka@pk.edu.pl*

Abstract

The paper describes design of the five-stroke engine developed in the Chair of Combustion Engines at Cracow University of Technology. The idea of five-stroke engine, in which the expansion ratio is significantly greater than the compression ratio has been presented by the Belgian engineer Gerhard Schmitz. The prototype of such an engine was made by Ilmor Engineering. Engine developers have released results of preliminary research, but there is no detailed information on the toxic exhaust emissions. For this reason, at Cracow University of Technology the research was undertaken to determine the impact of implementing the five-stroke cycle into the engine with spark ignition to reduce toxic emissions and increase total efficiency. To achieve this goal, the test engine was built, which is based on a concept similar to the idea of Gerhard Schmitz, with the difference that it has not been designed from the ground up, and it is based on an existing four-cylinder four-stroke engine. In comparison with the original solution, the engine built in Cracow has a completely different design of timing system, four valves per cylinder and petrol direct injection. This paper presents a detailed description of the engine design and the results of its preliminary research. The results of the tests of the five-stroke engine confirm an increase of specific torque and power (related to unit of engine displacement) and improve of total efficiency within a certain range of the engine map.

Keywords: *five-stroke engine, spark ignition, additional expansion, increase of total efficiency*

1. Introduction

Four-stroke internal combustion engine with spark ignition is known for about 150 years. During this time, it is subject to continuous and dynamic development. Despite this designers, as yet, failed to reduce fuel consumption in such a way that in a wide range of engine load and speed obtain total efficiency significantly greater than 35% [2]. From time to time there are signs of innovative designs, which are a revolution in the market for internal combustion engines due to the sensationally low fuel consumption and greatly reduced emissions, including their toxic components.

One of these engines is to be turbocharged five-stroke engine built in 2007 by a British research center - development Ilmor Engineering [1]. Presentation of the engine prototype was preceded patenting the invention in 2003 by the originator of the Belgian engineer Gerhard Schmitz [7]. Five-stroke engine concept diagram is presented in Fig. 1.

According to the concept of Gerhard Schmitz, both working (fired) cylinders 4 and 10 (high pressure) realize the classic four-stroke cycle. After the power stroke gases are not removed from them on the exhaust manifold and thence to the atmosphere, but are subject to additional expansion in the cylinder 7 (low pressure) of about twice the volume than the volume of each of the fired cylinders. Only after a further expansion stroke in the cylinder 7 occurs exhaust to the atmosphere in the next piston stroke. The above-described property of five-stroke engine causes the expansion ratio of medium in the engine is two times greater than the compression ratio.

The operation of combustion engine according to the above described concept results in an increase the proportion of energy converted into a positive work and, as a result, increase the efficiency of the cycle [4].

Referring to the ideas presented in Fig. 1, Tab. 1 summarizes the work order of five stroke engine cylinders.

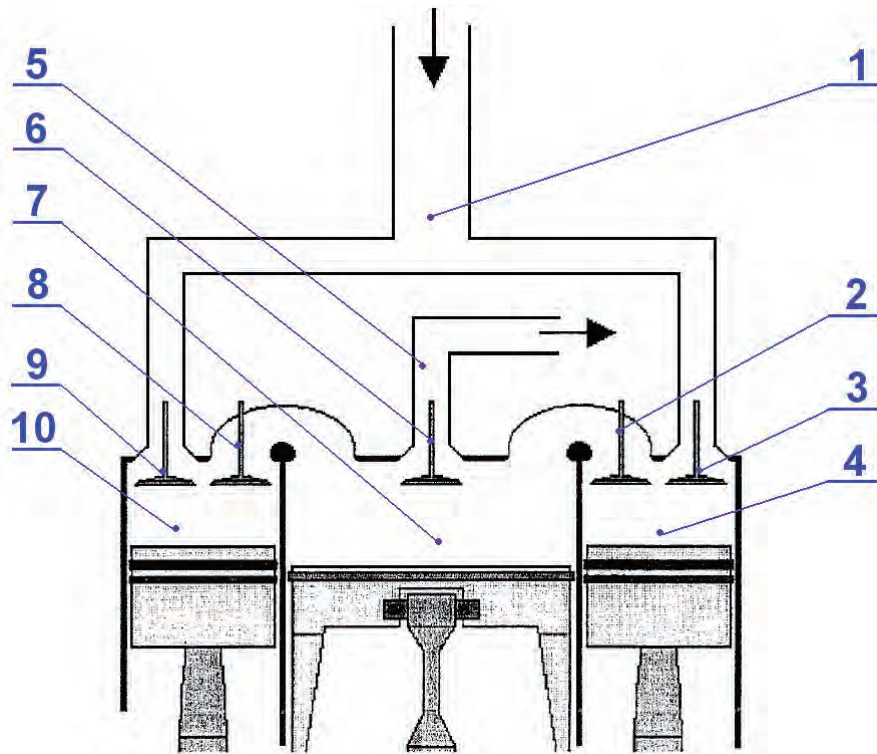

Fig. 1. Concept of the five stroke engine [7]: 1– Intake channel, 2, 8 – Valves between fired and additional expansion cylinders, 3, 9 – Intake valves, 4, 10 – Fired cylinders, 5 – Exhaust channel, 6 – Exhaust valve, 7 – Additional expansion cylinder

Tab. 1. The order of work of the five-stroke engine cylinders

Stroke No.	Process in the fired cylinder (10)	Process in the cylinder of additional expansion (7)	Process in the fired cylinder (4)
1	intake	exhaust to the atmosphere	power
2	compression	additional work during expansion of the medium	outlet into the additional cylinder
3	power	exhaust to the atmosphere	intake
4	outlet into the additional cylinder	additional work during expansion of the medium	compression
5	intake	exhaust to the atmosphere	power
...	compression	additional work during expansion of the medium	outlet into the additional cylinder
...	power	exhaust to the atmosphere	intake
...	outlet into the additional cylinder	additional work during expansion of the medium	compression

The processes occurring in successive strokes of the piston in one of the fired cylinders and additional expansion cylinder during one working cycle of the engine are highlighted by the use of different and bold font. Low pressure cylinder 7 is alternately supplied with exhaust gases from the fired cylinders 4 and 10, which makes it works in two-stroke cycle. Due to this fact five-stroke engine concept has been implemented including using a specific timing mechanism, which is shown in Fig. 2 together with crankshaft drive.

As can be seen from the above figure camshaft of intake valves and valves between high and low pressure cylinders is driven by the crankshaft of the ratio equal to 2, while camshaft of exhaust valves of the additional expansion cylinder rotates at the same speed as the engine crankshaft. As further seen convex piston crown working in the additional expansion cylinder, the use of which results in a reduction of its clearance volume.

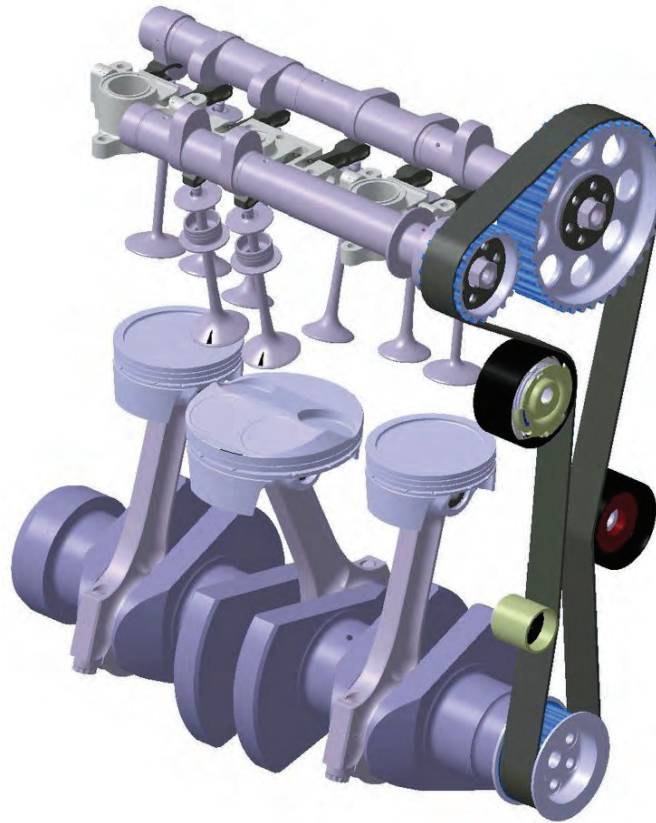

Fig. 2. Visualization of model of the crankshaft drive with and timing mechanism of the five-stroke engine [8]

2. Five-stroke engine concept developed at the Cracow University of Technology

In the Chair of Combustion Engines at Cracow University of technology research was undertaken to examine impact of the application of five-stroke cycle in the spark ignition engine on reduce toxic emissions and increase total efficiency [6]. Papers published by Gerhard Schmitz, and Ilmor Engineering does not contain detailed test results but only predictions regarding five-stroke engine emissions in comparison with four-stroke engine. This fact became an additional incentive interest in five-stroke engine from a scientific point.

Due to the no real possibilities to build from the ground a prototype the five-stroke engine by the research team in the the project's budget, it was decided to introduce far-reaching modifications to fit four-cylinder four-stroke engine so that it can realize the cycle with additional expansion of charge. Concept of of changes required to implement in the four-stroke engine is presented schematically in Fig. 3.

According to the concept presented in Fig. 4, it was decided that the process of further expansion of combusted mixture will take place in cylinders 2 and 3 connected through the passage in the cylinder head, while the cylinders 1 and 4 retain their original function. The connection of the cylinders 2 and 3 by the internal channel was made to obtain additional expansion volume two times higher than the swept volume of the fired cylinders.

A throughout modern four-stroke, four-cylinder turbocharged Audi SI engine with suffix BPG was selected as the object of undertaken task. The engine was donated for research purposes for Chair of Combustion Engines Institute of Automobiles and Internal Combustion Engines at Cracow University of technology by Volkswagen AG. The engine made in the four-valve technology has a displacement of 1.984 dm^3 and holds a maximum power of 147 kW drop-down in the rotational speed range of 5500 to 6000 rpm [5]. This engine comes from Volkswagen EA113 family. From the previous designs of this series is different by the fact that is equipped with a petrol direct injection system.

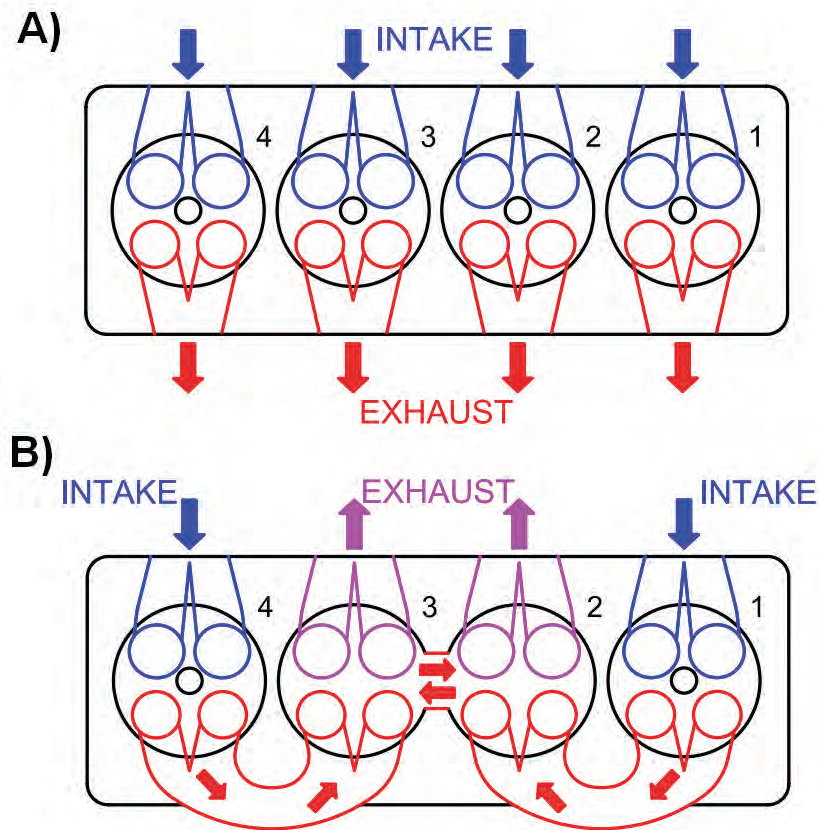

Fig. 3. Concept of modifications of design of the engine cylinder head; A) Four-stroke engine cylinder head, B) Engine cylinder head adapted to realize five-stroke cycle

The engine in original form was mounted on a test bench and the series of tests were made, the results of which were used as a reference for the results of tests of five-stroke engine. After testing the four-stroke engine started to realize actions which enabled adaptation of the engine to achieve five-stroke cycle. According to the approved concept the engine block with crankshaft drive and balance shafts did not need to make any modifications. In this case, the required conversion works has been focused on designing and making modification of the cylinder head, a completely new camshafts, intake and exhaust manifolds, boost system and other additional components.

Figure 4 shows the downstream side view of the test engine cylinder head in which they were made with a specialized milling cutter the passageways enabling the exhaust gas flow, respectively from the cylinder 1 to the cylinder 2 and from the cylinder 4 to the cylinder 3.

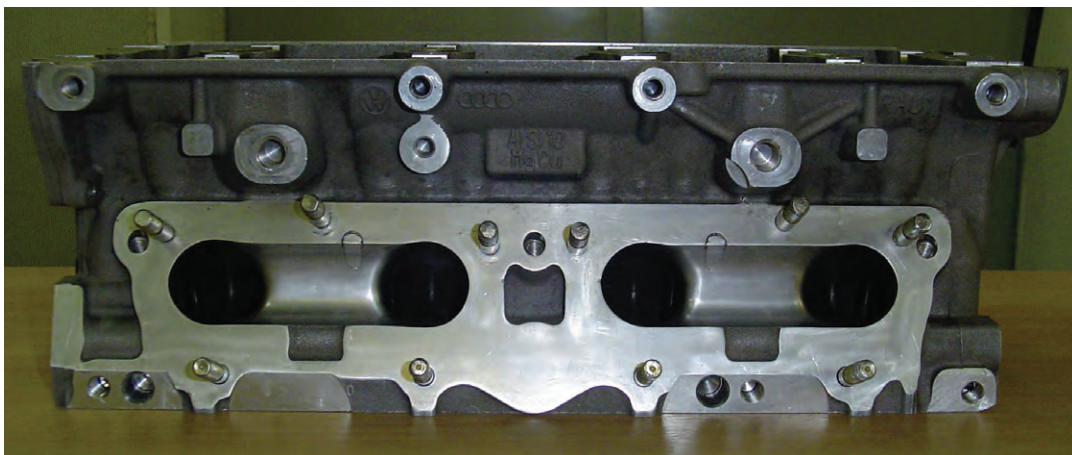

Fig. 4. Five-stroke engine cylinder head with channels connecting fired cylinders with additional expansion cylinders

The cross-section of the passageways in the head was approximately equal to half of the original cross-sectional area of the cylinder exhaust duct. Therefore, to preserve a roughly constant cross-sectional area, it should also perform the shaped grooves in the lids of channels.

A channel connecting assembly of additional expansion cylinders in one working volume was made in the material of the head. Fig. 5 shows the lower part of the cylinder head of the five-stroke engine with visible above mentioned channel.

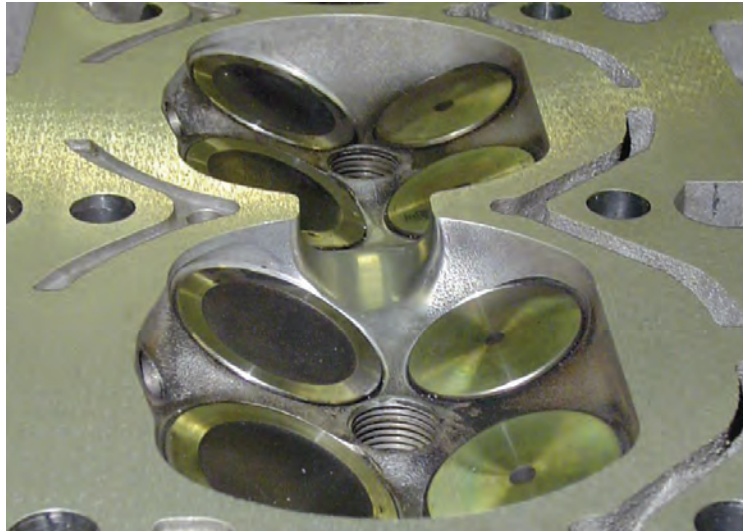

Fig. 5. Combustion chambers of cylinders 2 and 3 connected by a duct seen in the central part of the photo

Similarly, as in the case of passageways connecting the fired cylinders with the additional expansion cylinders, also in this case after the milling operation of groove the sharp edges and machined surfaces were smoothed and polished.

After completing cylinder head machining works towards achieving five-stroke cycle by the test engine it started to design new camshafts. The results of the simulations carried out in the GT-Power indicated valve timing ensuring correct gas exchange process in a wide range of engine operation map. A detailed description of the special design of the test engine timing can not be presented in this paper, because the application for patent it is in the preparation.

Implementation of five-stroke cycle to the test engine required to build from the ground the intake- and exhaust manifolds. Both of these elements are made of steel flanges, pipes and knees combined by welded joints. In the five-stroke engine the exhaust manifold is located in the direct neighbourhood to the intake manifold and the rail supplying fuel at high pressure to the injectors. This fact caused that it was necessary to insulate the exhaust manifold so that it minimally transfers heat to the intake manifold, and even more so to the adjacent parts of the fuel system. Thermal insulation of the exhaust manifold is made of basalt fabric with a maximum operating temperature of the wall more than 850 °C.

In addition to insulating the exhaust manifold the thermal insulation of neighboring elements was made which any warming could be disadvantageous. For this purpose, the elements surrounded by the exhaust manifold, such as the fuel rail, the fuel pressure regulator, the alternator and the cooling pipe have been coated with an insulating self adhesive tape with an aluminum foil reflecting heat.

KP39 type turbocharger applied to the five-stroke engine is manufactured by BorgWarner. This device is serially used in Ford EcoBoost SI engines of 1.6 dm³ displacement and maximum power of 110 kW. Applied turbocharger has a small moment of inertia of the rotor [3]. It also has a liquid cooling system and a waste-gate valve integrated in the turbine housing. The waste-gate valve is opened using a pneumatic actuator controlled by boost pressure modulated by a three-way valve. Apart from those specified above, activities carried out in order to realize five-stroke cycle in the

test engine, it was also necessary to perform a number of minor works that do not require detailed explanations. The above-mentioned works are:

- implementation of a completely new system of pipes for the supply and discharge of lubricating oil and coolant from the turbocharger,
 - changing the position of the air intercooler,
 - correction of course of engine cooling system connection pipes,
 - changing of position of intake and exhaust pipes,
 - modification of the engine crankcase ventilation,
- making correction in the course of the engine wire harness.

The above-mentioned changes were caused by the positioning of both the intake manifold and the exhaust manifold on one side of the five-stroke engine, while in the engine realizing four-stroke cycle, the exhaust manifold was on the opposite side than the intake manifold.

A general view of five-stroke engine installed on the test bench is presented on the Fig. 6.

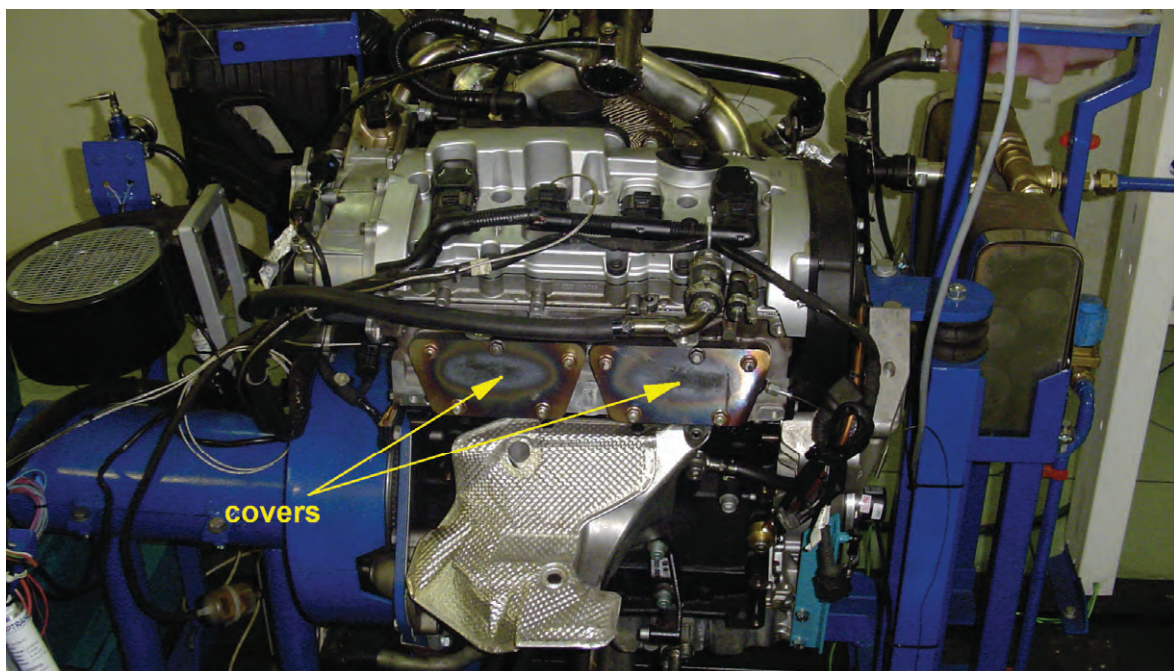

Fig. 6. A general view of five-stroke engine installed on the test bench

In the central part of the photo of Fig. 6 one can see the covers of channels for the flow of gas from the fired cylinder to the cylinder of additional expansion. The photo was taken after a series of tests on the engine in five-stroke version, so the discoloration visible on the covers are the result of thermal effects of hot working medium flowing through the channels.

3. Research of the five-stroke engine developed at Cracow University of Technology

The result of the preliminary test is comparison of the curves of specific torque, the specific power and specific fuel consumption for five-stroke engine and four-stroke engine. One can see it in the Fig. 7.

The test engine in five-stroke version has got a half of displacement of four-stroke engine, so in order to facilitate the analysis of obtained results, the torque and effective power shown in Fig. 8 are referenced to 1 dm³ of engine displacement. One can see increase of the specific power and specific torque generated by the engine in five-stroke version. Specific fuel consumption of the five-stroke engine shows favourable course of the four-stroke engine in a speed range from about 2600 to about 3900 rpm.

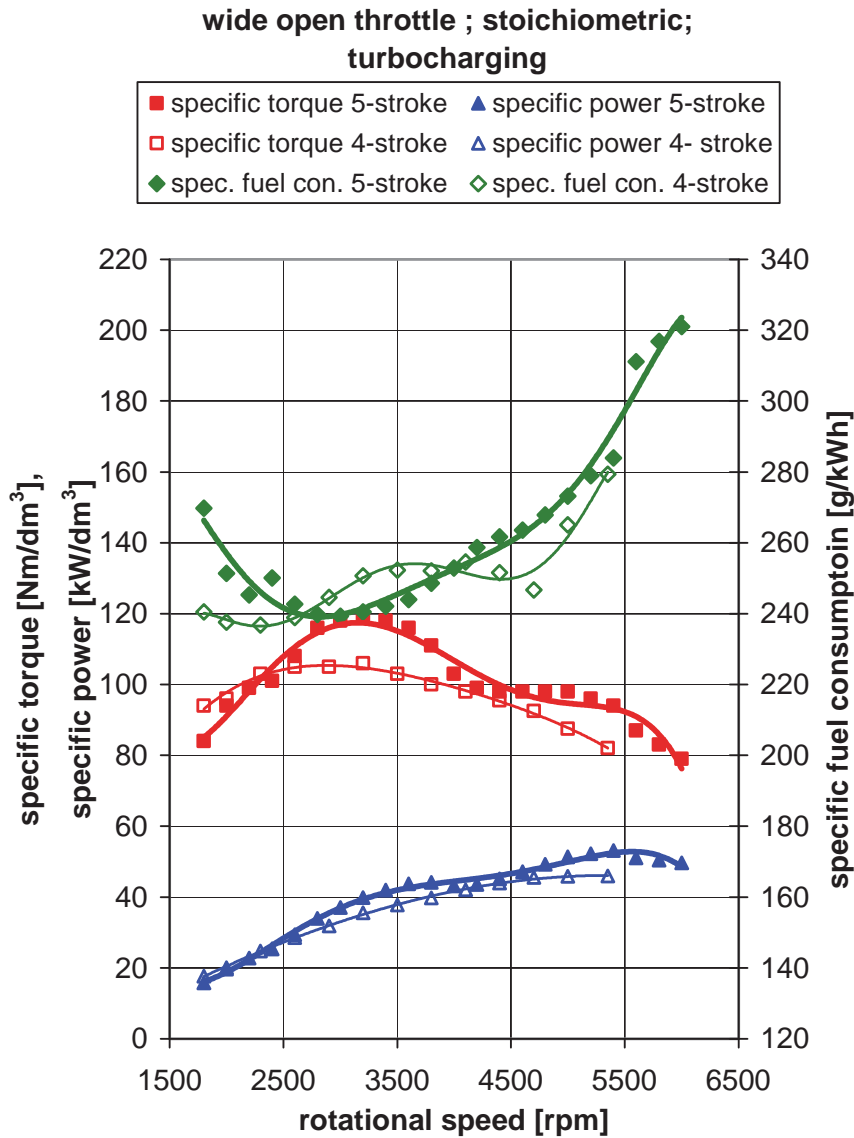

Fig. 7. Comparison of the curves of specific torque, the specific power and specific fuel consumption for five-stroke engine and four-stroke engine

4. Conclusions

Taking into account issues signalled in this article one can draw following conclusions:

- 1) the five-stroke engine, which has an additional exhaust gas energy recovery, is very interesting from a research point of view. Presented above preliminary results of tests of five-stroke engine developed on the basis of four-stroke engine confirms this thesis,
- 2) a further phase of the study concerned the analysis of operation under partial load and obtaining optimal settings of regulatory parameters due to the minimization of fuel consumption,
- 3) another issue was to determine the emission of exhaust gas components such as carbon dioxide, carbon monoxide, unburned hydrocarbons and nitrogen oxide. The further stages of work on the five-stroke engine will be presented in subsequent publications.

Acknowledgement

This project has been financed by National Science Centre of Poland.

References

- [1] Alten, H., Illen, M., Schmitz, G., *Thermodynamische Untersuchung eines 4-Taktmotors mit nachexpansion*, Ilmor Engineering Report TD-103, 1999.
- [2] Basshuysen, R. van, Schaefer, F., *Internal Combustion Engine. Handbook, Basics, Components, Systems and Perspectives*, SAE International, Warrendale 2004.
- [3] Fröhn, U., et. al, *Boost to the Max*, Turbo News 01/2011, BorgWarner Turbo Systems Worldwide Headquarters GmbH, Kirchheimbolanden 2011.
- [4] Postrzednik, S., Żmudka, Z., *Termodynamiczne oraz ekologiczne uwarunkowania eksploatacji tłokowych silników spalinowych*, Wydawnictwo Politechniki Śląskiej, Gliwice 2007.
- [5] Randal, M., *Audi A4 Owners Workshop Manual. Jan 2005 to Feb 2008*, ISBN 978 1 84425 885 7, Haynes Publishing, Sparkford 2010.
- [6] Rychter, T., Teodorczyk, A., *Teoria silników tłokowych*, Wydawnictwa Komunikacji i Łączności, Warszawa 2006.
- [7] Schmitz, G., *Five-stroke internal combustion engine*, United States Patent No. 6553977B2, 2003.
- [8] www.motortrivia.com/section-innovation/0012-ilmor/ilmor.html - accessed on 20.06.2013.