

A METHOD FOR MEASURING THE RADIATION PATTERN OF UHF RFID TRANSPONDERS

Piotr Jankowski-Mihułowicz, Mariusz Węglarski

*Rzeszów University of Technology, Faculty of Electrical and Computer Engineering, Pola 2, 35-959 Rzeszów, Poland
(✉ pjanko@prz.edu.pl, +48 17 854 4708, wmar@prz.edu.pl)*

Abstract

The operating principles of RFID antennas should be considered differently than it is applied in the classical theory of radio communication systems. The procedure of measuring the radiation pattern of antennas that could be applied to RFID transponders operating in the UHF band is seldom discussed correctly in the scientific literature. The problem consists in the variability of the RFID chip impedance that strongly influences measurement results. The authors propose the proper methodology for determining the radiation pattern with respect to an individual transponder as well as an electronically tagged object. The advantage of the solution consists in the possibility of using components of different measuring systems that are available in typical antenna laboratories. The proposed procedure is particularly important in terms of parameter validation – the identification efficiency and costs of an RFID system implementation can be evaluated properly only on the basis of real values of considered parameters.

Keywords: RFID, UHF transponder, antenna, radiation pattern.

© 2016 Polish Academy of Sciences. All rights reserved

1. Introduction

Intensive development of wireless systems that are widely used in various areas of life and economy [1] is evident in contemporary communications. The antenna radiation pattern is one of the basic parameters that are required to evaluate usefulness of a given radio communication system. Typically, it is defined as the amplitude distribution of the electric field strength on a spherical surface with a very large radius of curvature whereas the radiation source is located in the centre of the sphere [2]. The measurements of the radiation pattern are carried out in the far-field or near-field zone, regarding the purpose of a wireless communication system and a type of antenna [3, 4]. In the first case the measurements are performed directly, whereas in the second case transposition of the obtained results to the far-field region has to be applied – for this purpose the two-dimensional Fourier transformation is used [3, 5, 6]. If it is possible to establish a far-field in antenna laboratories, the pattern is measured in large anechoic chambers [3, 7] or in their small equivalents [8]. Also GTEM (*Gigahertz Transverse Electromagnetic Cell*) [8, 9] or reverberation chambers [10] can be used instead, in order to provide adequate conditions. In any type of chamber, the measuring area has to be adjusted to geometrical dimensions of antennas and their operating frequencies. If there is not enough space in order to establish a far-field during tests, then compact products (anechoic chambers with parabolic reflectors) are used as a substitute [3, 4, 11]. Dedicated polygon stands with the possibility of suppressing unwanted electromagnetic wave reflections can also be applied [4, 12, 13] to the considered tasks. Whatever alternative solution is chosen, it is necessary to use an advanced equipment in order to make the measurement process feasible in the frequency- [3–5] and time-domains [14].

A typical hardware and software configuration of the above mentioned measurement systems can be applied to determine the radiation pattern of most antennas that are commonly used in radio communication systems (DVB-T, GSM, UMTS, LTE, WiFi and others) [15]. It can also be adapted to new antenna constructions [16] as well as to new implementations of common antennas in wireless communications [17]. But there is a problem in RFID (*Radio Frequency Identification*) systems operating in UHF band (860–960 MHz, the operating frequency varies depending on world regions). It is impossible to determine the radiation pattern of RFID transponders by using standard laboratory stands and measurement methods. The problem consists in matching the impedance of the antenna and that of the chip. The complex impedance of RF front-end varies during the transponder chip working and its value is dependent on the electromagnetic field parameters (the electromagnetic field in RFID systems is influenced by environmental conditions around marked objects). It is the reason why the classical theory of antennas cannot be applied to solve the matching problem [18] and new measurement methods have to be developed in order to determine the parameters of RFID antennas.

The measurement process in which the nature of a UHF RFID transponder (the variable impedance of the chip) is taken into consideration is seldom described in the branch literature. In one of encountered solutions, the authors use a very expensive apparatus dedicated to the intended aim only [19]. In another proposal, supplementary (*e.g.* movable) antennas are implemented [20] but the described experiment is highly complicated and additional measurement uncertainties have to be taken into consideration.

With regard to the endeavours made to solve the above mentioned problems, the authors have worked out a universal method of radiation pattern determination and described it in detail in the paper. The main advantage of the proposed research methodology is the possibility of using a standard equipment of a typical antenna laboratory (such as an anechoic chamber, antenna positioners, *etc.*). The measurement stands are supplemented with cheap and commercially available RFID devices and some own control and data-acquisition software procedures. An additional benefit of the proposed method is that the radiation pattern can be determined just for a transponder as well as for a whole electronically marked object. The second option is particularly useful when the efficiency of identification process in automated systems and implementation or maintenance costs are considered [21].

2. UHF RFID system

In typical radio communication systems, the input impedance of a *transceiver* (TX) or a *receiver* (RX) is constant and equals to *e.g.* 50 Ω , 75 Ω . The impedance of antennas or signal paths in measurement instruments has to match the input value of the TX/RX circuits. Yet another problem appears in the RFID systems operating in the UHF band – the radiated electromagnetic wave of power density S (Fig. 1) is an energy medium supplying passive (without any built-in energy sources) or semi-passive (with an auxiliary battery) transponders. The carrier wave of frequency f_0 is used to transmit energy by matched antennas, but it should be noticed that the impedance matching of a transmitter and a receiver known from classical theory is valid only for the *Read/Write Device* (RWD) and its antenna (50 Ω). Unfortunately, matching of the transponder antenna with the chip cannot be considered in the way that is typical for radio communication systems.

The internal structure of an electronic chip is designed to be supplied by the minimal voltage U_T that is induced at terminals of the transponder antenna. As a consequence, the complex impedance (Z_{TC}) of the chip front-end is continuously changed. The part (Z_{TCR}) of the impedance that represents a rectifier and voltage regulator is strongly influenced by the electromagnetic field. On the other hand, the electromagnetic field parameters are dependent

on the orientation of marked object and its location in the operating space where both energy and communication conditions have to be established in order to ensure proper working of the system [22]. The conditions are described by the *Interrogation Zone* (IZ) that constitutes the basic parameter of RFID systems. It is defined as the space in which the two main tasks of an RFID system can take place: a) energy can be conveyed from the RWD to transponders and b) data can be transmitted in both directions [22, 23]. Since the amount of conveyed energy is very small, the backscatter communication is used for transmitting data in the direction from the transponder to the RWD. In this process, a battery-less device communicates by modulating its reflections of an incident RF signal. The modulation is realized by step changes of the chip impedance (Z_{TCM} switching). The communications principles are implemented in the protocol of *Electronic Product Code EPC Class 1 Gen 2* [24], standardized in ISO/IEC 18000-6.

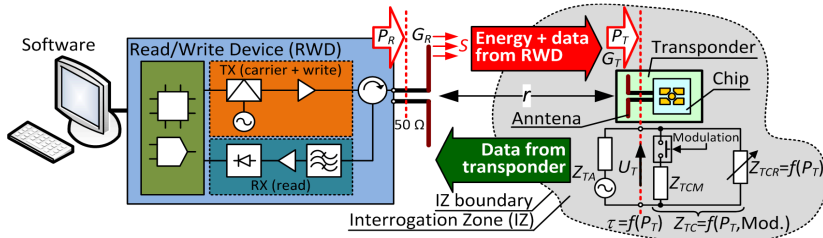

Fig. 1. A generalized block diagram of an UHF RFID system.

3. Proposed measurement method

The radiation pattern of the tested transponder antenna (AUT – *Antenna Under Test*) can be measured in the far-field that fulfils the condition:

$$r > \frac{2d^2}{\lambda}, \quad (1)$$

where: r means the distance between the AUT and a radiation source (an antenna of RWD in an RFID system); d is the maximal dimension of the AUT; and λ denotes the wavelength).

The main requirement for measurements to be carried out in a proper way is to maintain a constant value of the impedance Z_{TC} (Z_{TCR} without modulation) while polar diagrams of the radiation pattern (according to θ and ϕ angles of the spherical coordinate system) are being determined. The measuring procedure has to be performed when the transponder is placed inside the interrogation zone of an RFID system (the energy and communication conditions of transponder operation are met). The test conditions can be controlled only at the IZ boundary (Fig. 1). In the developed method, the authors propose to perform it by changing the power P_R supplied to the terminals of the impedance-matched RWD antenna.

The suggested procedure arises from the Friis transmission equation. The dependency on the power P_T received by the transponder antenna in a given RFID system can be described by the formula:

$$P_T = P_R \frac{G_R G_T \lambda^2 \tau \chi}{(4\pi r)^2}, \quad (2)$$

where: G_R means the gain of the impedance-matched RWD antenna; G_T – the gain of the transponder antenna (the chip and antenna impedance matching is assumed); χ – the polarization matching factor for a given arrangement of radio communications antennas; τ – the coefficient of power transfer from the antenna to the chip.

If the transponder changes its location inside the IZ, then the antenna impedance (Z_{TA}) is constant at a given frequency f_0 but the chip impedance (Z_{TC}) varies as a function of the power P_T . This dependency can be expressed by the following equation [22]:

$$\tau(P_T) = \frac{4 \operatorname{Re}(Z_{TA}) \operatorname{Re}[Z_{TC}(P_T)]}{\{\operatorname{Re}[Z_{TA} + Z_{TC}(P_T)]\}^2 + \{\operatorname{Im}[Z_{TA} + Z_{TC}(P_T)]\}^2}, \quad (3)$$

where Re describes the real and Im – imaginary part of the complex impedance.

Power received in the transponder antenna is equal to the minimal value P_{Tmin} if the terminals of the impedance-matched RWD antenna are supplied with the minimal power P_{Rmin} . It enables the transponder to be properly supplied (in given environmental conditions) according to the relation:

$$P_{Tmin} = P_{Rmin} \frac{G_R G_T \lambda^2 \tau \chi}{(4\pi r)^2}. \quad (4)$$

The (4) dependency is crucial for the IZ boundary determination where the impedance Z_{TC} is equal to $Z_{TCR} = f(P_{Tmin})$ [22]. This impedance is obtained on the basis of a communication protocol in the task process where the transponder sends its unique identification number (UID – *Unique Identifier*) as an answer to the *Query* command from the RWD [24]. The requirement of maintaining a constant value of the chip impedance that is met when the condition $P_T = P_{Tmin}$ is true for any variation of θ and ϕ angles at the constant distance r , is fundamental for the authors' method of measuring the radiation pattern (Fig. 2).

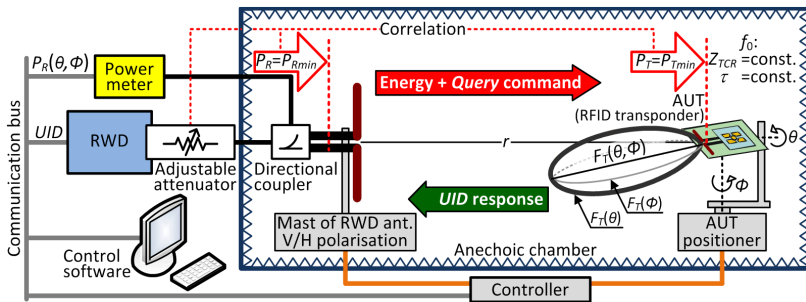

Fig. 2. A block diagram of the proposed method for measuring the radiation pattern.

Since the chip impedance is complex ($\neq 50 \Omega$), the radiation pattern is determined wirelessly. It means that signal paths of measuring devices do not have to be connected to the transponder chip by wires and the radiation plots can also be drawn for electronically marked objects. The test procedure is performed in an anechoic chamber equipped with an AUT positioner, a linear polarized RWD antenna with a mast, and a digital controller.

A small anechoic chamber can be chosen for the test purposes [8] according to the dimensions of transponders and their operating frequency band. The amount of power conveyed to the tested transponders can be controlled by the RWD and an output attenuator. The normalized radiation pattern (in dB) is determined on the basis of the following dependency:

$$F_{Tn \text{ dB}}(\theta, \phi) = \left[P_{R \text{ dBm}}(\theta, \phi) \right]_{\min} - P_{R \text{ dBm}}(\theta, \phi), \quad (5)$$

where: $P_{R \text{ dBm}}$ is the measured power in dBm (by using a scope probe, a spectrum analyser, etc.) whereas the „min” index refers to the minimal value of this parameter.

4. Experiment

Two samples of semi-passive transponders operating in the UHF band have been designed to verify the elaborated method. Both transponders are equipped with an AMS SL900A [25] chip and an omnidirectional antenna in the first case or a directorial antenna in the second one [26]. Two different laboratory stands have been prepared in order to perform the test procedures of the evaluated radiation pattern. The common components of radio communications test sets (anechoic chambers, positioners, *etc.*) that are typically dedicated to measure radiation patterns of standard antennas have been used to build up the new stands for the method proposed by the authors. In addition, commercially available and relatively cheap RFID devices (comparing with the equipment for common antenna tests) have been implemented in the stand with the aim of adjusting the antenna laboratory to the proposed research. Moreover, own control procedures have been designed in order to adapt the apparatus to the scheduled tests. To evaluate the obtained results, the radiation pattern has been measured twice: using first the authors' method and then the classical method, in the same experimental conditions.

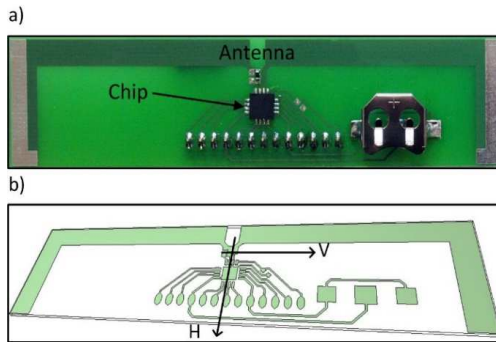

Fig. 3. A UHF RFID transponder with an omnidirectional antenna: a) sample #1; b) an HL3DEM antenna model.

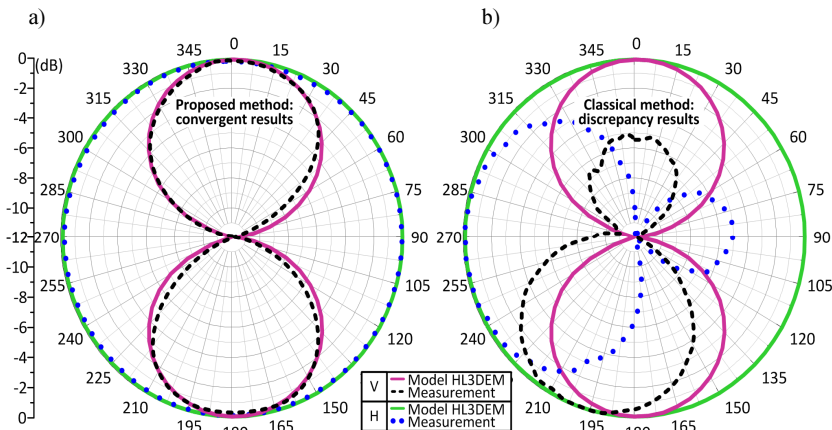

Fig. 4. A diagram of the antenna radiation pattern at 866 MHz – sample #1: a) comparison of plots obtained with the numerical calculation and the authors' method; b) comparison of plots obtained with the numerical calculation and the classical method.

The verification process of the method starts from designing antenna models of the tested semi-passive transponders. The numerical model of the omnidirectional antenna (Fig. 3a) is created in HyperLynx 3D EM (HL3DEM) software (Fig. 3b).

In the second step, the radiation pattern is measured and plotted at the specially prepared laboratory stand equipped with the designed software tools. Comparison of the measured and calculated characteristic diagrams are plotted in a V-vertical (X-Z) and H-horizontal (Y-Z) plane (Fig. 4a).

The measurement set-up for the authors' method is presented in Fig. 5 and consists of an MVG EQ7922-01 anechoic chamber, a one-axis positioner, a designed directional antenna (with linear polarization) connected with RWD (Feig ID ISC.LRU2000) by duplex rotary step attenuators (Telonic Berkeley 8052S), and a 6 dB directional coupler (Pasternack PE2238-6). The process parameters and transmitted power are supervised by a spectrum analyzer (Tektronix RSA 3408B) with a built-in protocol decoder EPC Class 1 Gen 2. The system is controlled by the software tool *RFID(UHF)SysAntPat* implemented in LabView.

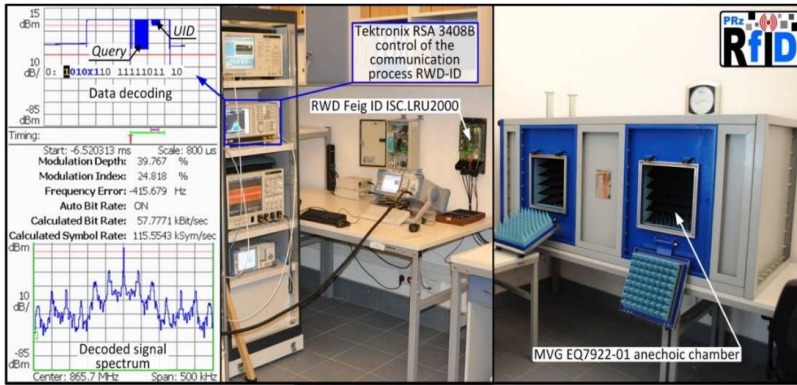

Fig. 5. The first test stand – sample #1.

In the third step – executed only for comparison reasons – the radiation pattern is measured by means of the classical method (Fig. 4b) under the same environmental conditions (anechoic chamber, positioner). The comparison measurements are made for the transponder antenna which is connected directly to one of the VNA ports (Keysight N9912A FieldFox). The impedance mismatch between the AUT and the signal paths in VNA ($Z_{TA} \neq Z_0$ where the characteristic impedance Z_0 of a signal line is 50Ω) leads to divergent results due to a large-signal reflection (Fig. 4b). This phenomenon results from a special antenna construction that is adjusted to the RF front-end of UHF RFID transponder. The voltage reflection coefficient Γ at the input terminals of the transponder antenna can be expressed by the following equation [2]:

$$\Gamma = \frac{Z_{TA} - Z_0}{Z_{TA} + Z_0}. \quad (6)$$

On the basis of [27], the measured antenna impedance Z_{TA} in this case is $64.9 + j300 \Omega$ at $f_0 = 866 \text{ MHz}$. This value is adjusted to the SL900A chip, where the measured chip impedance Z_{TC} is equal to $14.9 - j342 \Omega$ at the frequency 866 MHz for the passive mode ($\tau = 0.477$). The Z_{TC} value is obtained at the measured sensitivity $P_{Tmin} = -13.1 \text{ dBm}$. On the basis of (6), the reflection coefficient is close to unity ($|\Gamma| = 0.935$) for the transponder antenna connected directly to one of the VNA ports (Fig. 4b) and it is the reason of huge discrepancies in the plots.

The similar verification procedure has been carried out for the second sample #2. In this case, the development board of the autonomous semi-passive RFID transponder with a directional antenna of the UHF band (Fig. 6a) has been tested.

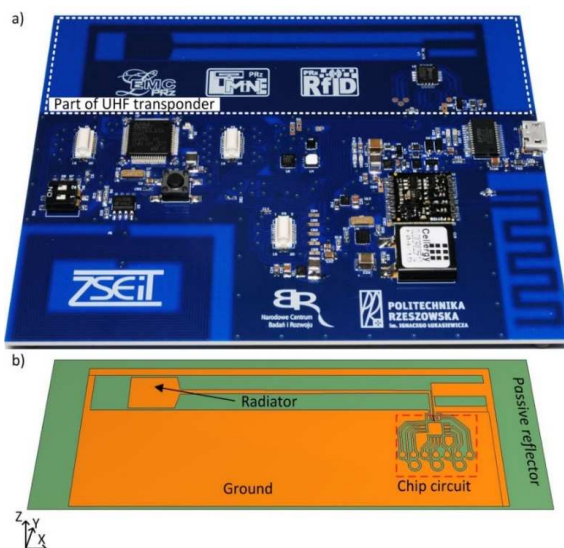

Fig. 6. A development board of the autonomous semi-passive RFID transponder: a) sample #2; b) an HL3DEM model of the UHF directional antenna.

Comparison of the measured and calculated characteristic diagrams is plotted in a V-vertical (X–Z) and H-horizontal (Y–Z) plane (Fig. 7). The proposed measurement set-up for the second experiment is presented in Fig. 8 and consists of a TDK anechoic chamber, a one-axis positioner (Dream Catcher ME1300), a directional antenna (with linear polarization) connected with the RWD (IDS R903) by duplex rotary step attenuators (Telonic Berkeley 8052S), and a 6 dB directional coupler (Pasternack PE2238-6). The process parameters and transmitted power are supervised by the RWD. The system is controlled by the software tool *RFID(UHF)SysAntPat* implemented in LabView.

On the basis of [26], the measured antenna impedance Z_{TA} in this case is $42.2 + j363 \Omega$ at $f_0 = 866$ MHz. This value is adjusted to the SL900A chip impedance at the frequency $f_0 = 866$ MHz for the passive mode ($\tau = 0.68$). As in the first case, the reflection coefficient is also close to unity ($|\Gamma| = 0.969$) for the transponder antenna connected directly to one of the VNA ports. The impedance mismatch between the AUT and the signal paths in VNA leads to divergent results due to a large-signal reflection (Fig. 7b).

The measurements with the authors' method are performed at the distance of $r = 0.35$ m in both arrangements. At this distance the signal of wave reflected by the transponder can be detected for all positions of the antenna rotated by the positioner ($0-360^\circ$ with step 5°). The results of measurements and calculations, obtained in both experiments are convergent for the V as well as H plane of the radiation pattern. It confirms usefulness of the developed method. The minor discrepancies are caused due to the use of an infinite plane for the dielectric layer in the prepared HL3DEM numerical models. The impedance mismatch between the transponder antenna and the signal paths in the classical method with VNA precludes the radiation pattern of the RFID UHF transponder from being determined. Moreover, the authors' method can be

also adapted to determine (in a non-classical way) the power gain G_T of antennas which impedance matches that of the transponder chip.

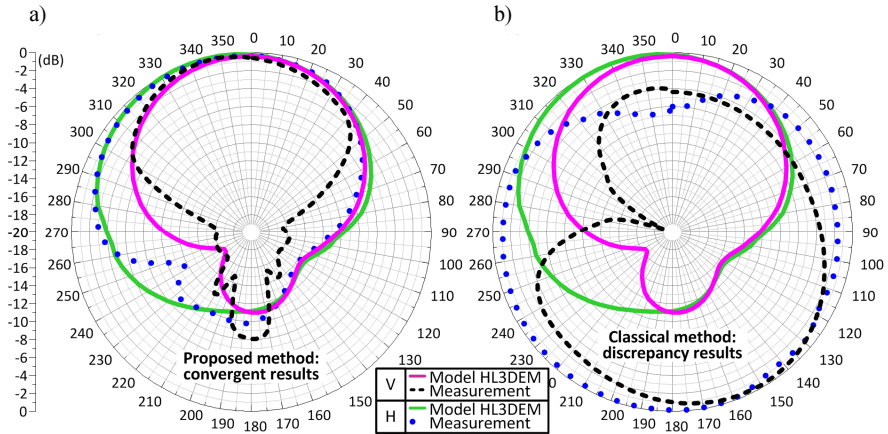

Fig. 7. A diagram of the antenna radiation pattern at 866 MHz – sample #2: a) comparison of plots obtained with the numerical calculation and the authors' method; b) comparison of plots obtained with the numerical calculation and the classical method.



Fig. 8. The second test stand – sample #2.

5. Conclusion

The radiation pattern of classical antennas operating in common radio communication systems is determined by dint of the standard equipment that is available in most specialized research RF laboratories. Unfortunately, the RFID antennas operate in the way that not always can be described by the classical theory of antennas. It is the reason why some wrong characteristics appear in the literature and it is hard to find measurement procedures that are properly described and where the variability of chip impedance in the UHF band is considered correctly. In view of that, the authors have proposed a universal method for determining the radiation pattern. No expensive re-built experimental stand is necessary to apply the method in a traditional antenna laboratory as only standard RFID devices, which are commercially

available, are needed as a supplement. The idea of the measurement procedure is described on the basis of the communication process between the RWD and the transponder in an RFID system of the UHF band. The elaborated conception has been verified and developed in experimental tests on two examples: omnidirectional and directorial antennas, designed especially for commercial RFID chips. The research has been performed in the authors' RFID laboratory.

Acknowledgements

This work was supported in part by the Polish National Centre for Research and Development (NCBR) under Grant No. PBS1/A3/3/2012. The work was developed by means of the equipment purchased in the Operational Program Development of Eastern Poland 2007-2013 of the Priority Axis I Modern Economics of Activity I.3 Supporting Innovation under Grant No. POPW.01.03.00-18-012/09-00 and the Program of Development of Podkarpacie Province of The European Regional Development Fund under Grant No. UDA-RPPK.01.03.00-18-003/10-00.

References

- [1] Du, K., Swamy, M.N.S. (2010). *Wireless Communication Systems: From RF Subsystems to 4G Enabling Technologies*. 1st ed., Cambridge University Press.
- [2] Balanis, C.A. (2005). *Antenna Theory*. 3rd ed., Wiley-Interscience.
- [3] ANSI/IEEE (1979). IEEE Standard Test Procedures for Antennas, Std 149-1979 (R2008).
- [4] Gillespie, E.S. (1988). Measurement of Antenna Radiation Characteristics on Far-Field Ranges. Lo, Y.T., Lee, S.W. *Antenna Handbook*, ch. 32, New York: Springer.
- [5] Appel-Hansen, J. (1988). Near-Field Far-Field Antenna Measurements. Lo, Y.T., Lee, S.W. *Antenna Handbook*, ch. 33, New York: Springer.
- [6] Kobayashi, H., Singh, D., Yamaguchi, Y. (2011). Near-field to far-field transformation by using antenna array factor. *Proc. of 3rd APSAR 2011.*, Seoul, Korea.
- [7] Munteanu, I., Kakerow, R. (2014). Simulation Methodology for the Assessment of Field Uniformity in a Large Anechoic Chamber. *IEEE Trans. Magn.*, 50(2), 213–216.
- [8] Icheln, C. (2001). *Methods for Measuring RF Radiation Properties of Small Antennas*. PhD Dissertation. Helsinki University of Technology, Espoo, Finland.
- [9] Tian-Hong, L., Alexander, M.J. (2006). A Method to Minimize Emission Measurement Uncertainty of Electrically Large EUTs in GTEM Cells and FARs Above 1 GHz. *IEEE Trans. Electromagn. Compat.*, 48(4), 634–640.
- [10] Garcia-Fernandez, M.A., Carsenat, D., Decroze, C. (2014). Antenna Gain and Radiation Pattern Measurements in Reverberation Chamber Using Doppler Effect. *IEEE Trans. Antennas Propag.*, 62(10), 5389–5394.
- [11] Dau-Chyrh, C., Chao-Hsiang, L., Chih-Chun, W. (2004). Compact antenna test range without reflector edge treatment and RF anechoic chamber. *IEEE Antennas Propag. Mag.*, 46(4), 27–37.
- [12] Martinod, E., Lalande, M., Feix, N., Bertrand, V., Rammal, R. (2014). Measurement of antenna radiation patterns out of anechoic chamber: UWB transient facility in frequency band [300 MHz–3 GHz]. *Proc. of IEEE CAMA 2014*, Juan-les-Pins, Antibes, France.
- [13] Cano-Facila, F.J., Burgos, S., Martín, F., Sierra-Castañer, M. (2011). New Reflection Suppression Method in Antenna Measurement Systems Based on Diagnostic Techniques. *IEEE Trans. Antennas Propag.*, 59(3), 941–949.
- [14] Blech, M.D., Leibfritz, M.M., Hellinger, R., Geier, D., Maier, F.A., Pietsch, A.M., Eibert, T.F. (2010). Time-Domain Spherical Near-Field Antenna Measurement System Employing a Switched Continuous-Wave Hardware Gating Technique. *IEEE Trans. Instrum. Meas.*, 59(2), 387–395.

- [15] Parini, C., Gregson, S., McCormick, J., van Rensburg, D. J. (2014). *Theory and Practice of Modern Antenna Range Measurements*. IET.
- [16] Ito, T., Tsutsumi, Y., Obayashi, S., Shoki, H., Morooka, T. (2009). Radiation pattern measurement system for millimeter-wave antenna fed by contact probe. *Proc. of European Microwave Conference 2009*, Rome, Italy, 1543–1546.
- [17] Farzaneh, S., Ozturk, A.K., Sebak, A. R., Paknys, R. (2009). Antenna-Pattern Measurement Using Spectrum Analyzer for Systems with Frequency Translation. *IEEE Antennas Propag. Mag.*, 51(3), 126–131.
- [18] Jankowski-Miśulowicz, P., Pitera, G., Węglarski, M. (2014). The Impedance Measurement Problem in Antennas for RFID Technique. *Metrol. Meas. Syst.*, 21(3), 509–520.
- [19] Ukkonen, L., Sydanhelmo, L. (2010). Threshold Power-based Radiation Pattern Measurement of Passive UHF RFID Tags. *Proc. of Progress in Electromagnetic Research Symposium 2010*, Cambridge, USA, 87–90.
- [20] Abdulhadi, A.E., Abhari, R. (2012). Design and Experimental Evaluation of Miniaturized Monopole UHF RFID Tag Antennas. *IEEE Antennas Wireless Propag. Lett.*, 11, 248–251.
- [21] Ustundag, A. (2013). *The Value of RFID. Benefits vs. Costs*. London: Springer-Verlag.
- [22] Jankowski-Miśulowicz, P., Węglarski, M. (2014). Determination of Passive and Semi-Passive Chip Parameters Required for Synthesis of Interrogation Zone in UHF RFID Systems. *Electronics and Electrical Engineering*, 20(9), 65–73.
- [23] Finkenzeller, K. (2010). *RFID Handbook*. 3rd ed., Wiley.
- [24] GS1 EPCglobal. (2013). EPC Radio-Frequency Identity Protocols Generation-2 UHF RFID; Specification for RFID Air Interface Protocol for Communications at 860 MHz – 960 MHz, ver. 2.0.0.
- [25] AMS. (2014). SL900A EPC Class 3 Sensory Tag Chip – For Automatic Data Logging. Datasheet, v1-01.
- [26] Jankowski-Miśulowicz, P., Kawalec, D., Węglarski, M. (2015). Antenna Design for Semi-Passive UHF RFID Transponder with Energy Harvester. *Radioengineering*, 24(3), 722–728.
- [27] Jankowski-Miśulowicz, P., Lichoń, W., Pitera, G., Węglarski, M. (2014). Impedance Matching Between Antenna and Chip in RFID Transponder of UHF Band. *Elektronika*, 1, 41–43.