

## THE EFFECT OF COMPENSATION, CAREER DEVELOPMENT, WORK-FAMILY SUPPORT ON JOB SATISFACTION

Tobing D.S.K.\*

**Abstract:** The objective of this study was to analyze the effect of compensation, career development, and work-family support on job satisfaction. The sample consisted of 175 employees working in state-owned banks in Jember Regency, East Java, Indonesia. Multiple linear regression was used to test the proposed hypothesis. The results showed that compensation and work-family support had significant effects on job satisfaction. On the other hand, career development did not significantly affect job satisfaction.

**Key words:** compensation, career development, work-family support, job satisfaction, state-owned enterprise's banks

DOI: 10.17512/pjms.2016.14.1.19

*Article's history:*

*Received* October 27, 2016; *Revised* November 30, 2016; *Accepted* December 3, 2016

### Introduction

Professionals of human resource management provide definition and review of job satisfaction from different perspectives. But, in general, job satisfaction is defined as an attitude and a feeling of a worker toward their job. Job satisfaction is an effective or emotional response to various aspects of the job. This definition means that job satisfaction is not a single concept. A person can be relatively satisfied with one aspect of the job, but not satisfied with the other aspects. Job satisfaction is the way people evaluate their feeling about the job. The evaluation can vary from the top level of satisfaction to the top level of dissatisfaction. Job satisfaction is influenced by people in the workplace, supervisor, co-workers, compensation, and the work environment (George and Jones, 2008).

The compensation theory still has some limitations in explaining individual satisfaction as the results of the performance. Before the compensation theory offered a number of methods about the payment system, organizations typically used a set of relevant factors to determine individual payment. The labor market, the organization condition, the work level, and the employee qualification, all will influence how the job pricing is determined and finally this would affect the rate of an individual's financial compensation. These factors continue to play an important role. However, for more and more companies, the world has become the marketplace. As the global economy increasingly determined the cost of labor, the global labor market growth is a determinant of financial compensation for individuals. With the labor costs accounting for more than 50 percent of the sales

---

\* **Diana Sulianti K. Tobing**, Faculty of Economics, University of Jember

✉ Corresponding author: dskltse@yahoo.com

in average, it is reasonable for employers to outsource an increasing number of the jobs to a cheaper foreign labor.

Company management designs a career development system to create a job satisfaction of the employee. In addition, the company will be helped by the new prospective leaders who have the skills and work experiences in formulating the company's strategy (Stringer and Cheloha, 2003). Career development should be implemented effectively because it can affect the sustainability of the company (O'Donnell, 2007). For individuals, support from the family to their job can result in better behavior in the workplace (Anderson et al., 2002; Behson, 2005). Support from the organization will also help employees in balancing their personal role as the family member and the professional role as the employee that will finally minimize or avoid the work-family conflict (Allen, 2001). Frone (2003) stated that the work-family support is the extent to which participation at work (or home) is easier by virtue of the experiences, skills, and opportunities gained or developed at home (or work). Work-family conflict could occur if there is one role that dominate or overpower other roles and if this continues, conflicts are inevitable that will finally affect the work performance of the individuals (Greenhaus and Beutell, 1985).

### **Literature Review**

Compensation is a reward given by the company to individuals in the businesses. Compensation can lead to increased motivation and performance of individuals, although in some cases this is not always significant. Compensation can lead to changes in better individual behavior. This is due to expectations of the individual to gain a higher level of compensation by performing good behavior (Wruck, 2000; Tobing, 2009). An attractive compensation level can improve individual's skills and job satisfaction (Grace and Khalsa, 2003). Improvement of individual skills is needed by the company to win the competition. Kreitner and Kinicki's model (2006) showed that compensation is the important factor that generates individual job satisfaction.

Career development management is designed with the aim to make people satisfied with the company. As mentioned previously, the company will be helped by the prospective new leaders who have the skills and work experiences in formulating the company's strategy (Stringer and Cheloha, 2003). The success of career development program will affect the sustainability of the company (O'Donnell, 2007). Human resource management practitioners should ensure that career development system in the company is in compliance with employee satisfaction and business development. Employee satisfaction can be achieved by making a good career development system and giving an understanding of how important the system is that designed by the company for managerial and professional staffs (McCracken, 2002; Rutherford, 2005). Behson (2005) found that informal work-family support is managed better than formal work-family support. This condition generates behavioural outcomes. The work-family support was examined by

Anderson et al. (2002) using respondents from different jobs and companies. The results showed that the family support to the employee's work had a significant effect on job satisfaction.

In general, a concept provided by professionals of human resource and organizational management concludes that job satisfaction is an attitude and a feeling of a worker toward their work. Gibson et al. (1997) stated that job satisfaction is an attitude that individuals have about their job. Attitude as the result from the way individuals feel about the job itself, about their supervisor, compensation, work policies and procedures, and working condition. Job satisfaction is the level of individuals' positive or negative feeling about their job. The feeling can be in the form of an emotional response to their tasks, as well as the physical and social conditions of the workplace. Individual psychological contract is something that becomes an achievement to produce job satisfaction (Schermerhorn et al., 1991; Tobing, 2008). There are three characteristics of job satisfaction (Spector, 1997). First, organizations should be guided by human values. The organization should be directed to the concept that individual is a precious asset of the organization. Human is a social being who can think and their needs are always changing. A human has the ability and skills that can be used by companies to make a profit as long as work satisfaction is met. Second, job satisfaction will produce the perception and ultimately will result in behavior. This behavior is required in delivering performance. Individuals who are satisfied with their work will perform good behavior and vice versa, those who are not satisfied with their work usually will perform bad behavior. Third, job satisfaction sometimes used as the indicator in managing a company. The monitoring process of individual job satisfaction will provide feedback for the company. If people are satisfied, then they will increase their work performance.

### Methodology

The population of this study was all employees of state-owned banks in Jember, one of the regencies in East Java, Indonesia, with the total number of 515 people. Research sample was consisted of 175 respondents. To analyze the effect of independent variables on the dependent variable, multiple linear regression analysis was employed. The model of the multiple linear regressions is as follows:

$$Y_i = b_0 + b_1X_1 + b_2X_2 + b_3X_3 + e \quad (1)$$

$Y_i$	= Job Satisfaction
$b_0$	= Constanta
$b_1, b_2, b_3$	= Coefficient of partial regression
$e$	= Error variable
$X_1$	= Compensation
$X_2$	= Career development
$X_3$	= Work-family support

In a structural equation with many variables and paths between variables, there are significant influences between variables, which include direct, indirect, and total effects. A direct relationship occurs between latent exogenous variables which are compensation, career development, and work-family support with endogenous variable which is job satisfaction. There are three direct effects on job satisfaction (Y), which is compensation ( $X_1$ ) on job satisfaction, career development ( $X_2$ ) on job satisfaction, and work-family support on job satisfaction ( $X_3$ ). This suggests that the latent exogenous variables provide a major contribution in influencing job satisfaction. In accordance with the purpose of the research and literature review, this study proposes a research framework as shown in Figure 1. Compensation, career development, and work-family support are the independent variables, while job satisfaction is the dependent variable.

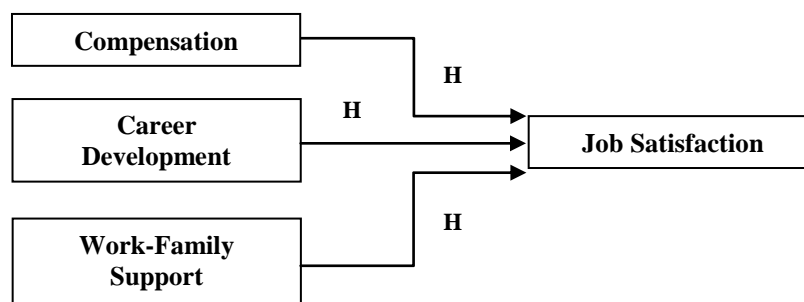

Figure 1. Research framework

Research hypotheses:

*H1: Compensation has significant effect on job satisfaction*

*H2: Career development has significant effect on job satisfaction*

*H3: Work-family support has significant effect on job satisfaction*

### Results and Discussion

Internal consistency reliability was measured using Cronbach alpha ( $\alpha$ ). The results were in accordance with the assessment criteria that have been determined. The Cronbach's alpha values for each variable such as compensation, career development, work-family support, and job satisfaction were bigger than 0.60. This means that all variables in this study were reliable and could be analyzed using multiple regression analysis. The t-test was used to test the partial effect of independent variables on the dependent variable. Table 1 presents the results the multiple linear regression analysis.

According to Table 1, compensation ( $\beta = 0.775$ ) has a significant effect on job satisfaction. The t-value shows that compensation is significant (p-value < 0.001).

It means that H1 is accepted or it is proved that compensation significantly affects job satisfaction of employees working in state-owned banks in Jember, Indonesia.

**Table 1. Results of regression analysis**

Model	Unstandardized Coefficients		Standardized Coefficients	t	Sig.
	B	Std. Error	Beta		
(Constant)	0.304	0.286		1.022	0.304
Compensation (X <sub>1</sub> )	0.812	0.091	0.775	8.908	0.000
Career Development (X <sub>2</sub> )	0.136	0.099	0.130	0.768	0.456
Work-Family Support (X <sub>3</sub> )	0.698	0.095	0.699	7.314	0.000

\* p<0.05, \*\*p<0.01, \*\*\*p<0.001

Based on respondents' assessment, the result that compensation has significant effect on job satisfaction is perceived by the employee. This is due to the good compensation scheme, which then increases job satisfaction of the employees.

The results of this study are consistent with the research by Judge and Watanabe (2010) stating that compensation significantly affects employee satisfaction. Compensation can positively affect job satisfaction. Markiewicz et al. (2000) also found that the compensation has significant effect on employee's job satisfaction.

Career development ( $\beta = 0.130$ ) has no significant effect on job satisfaction. The t-value shows that career development is not significant (p-value > 0.001). It means that H2 is rejected or career development does not significantly affect job performance of the employees working in state-owned banks in Jember, Indonesia. This result is supported by the votes about the career development that, in general, employees have enough votes to agree and disagree. It can be interpreted that the employee had fairly good perception on job satisfaction that is applied in state-owned banks in Jember.

The results of this study indicate that career development as part of a system influences the internal behavior of employees in improving their job satisfaction. The career development system is actually rooted in the organization itself for each individual as the member of the organization. Each individual has a belief in certain things which is believed to be true (beliefs), which, when subsequently confirmed in their everyday lives, it will be individual value that believed as a good thing to do (value). More importantly, good career development, through the process of adopting the interests of employees and organization, can be manifested when it is actualized in the daily behavior of all members of the organization. The results of this study are consistent with the research by Burke and McKeen (1995) stating that career development affects employee satisfaction. Types of abilities, skills, and fulfillment of tasks can influence employee career development.

Work family support ( $\beta = 0.699$ ) has a significant effect on job satisfaction. The t-value shows that compensation is significant ( $p\text{-value} < 0.001$ ). It means that H3 is accepted or it can be stated that work-family support significantly affects job satisfaction of the employees working in state-owned banks in Jember, Indonesia. Full support from the family toward the employees will positively impact their work performance, which then increases job satisfaction.

The results of this study are consistent with a research by Greenhaus et al. (2001) concluding that the work-family support has a significant effect on job satisfaction. The influence of work-family support will help employees to be more focus on completing their job. Work-family support can produce a high job satisfaction that will finally affect employee performance.

### **Conclusion**

The first hypothesis of the study was about the effect of compensation on job satisfaction. Results showed that compensation significantly affects job satisfaction, supporting hypothesis 1. The better the system of compensation provided by the company to the employees, the higher the levels of employees' satisfaction. The higher the degree of satisfaction, the higher the level of employee motivation in achieving high performance. Compensation helps companies to achieve their goals in obtaining, maintaining, and keeping the optimum work performance of the employees.

The second hypothesis was about the effect of career development on job satisfaction. The results showed that career development had no significant effect on job satisfaction, so the second hypothesis was rejected. This study found that if the employees have difficulty in developing their career in the company, they would think of finding a new job in another company that can understand them and provide a better opportunity to develop a career and gaining a better position. This is because a good career development system will motivate employees to perform better which will directly give a positive impact to the company. Career development system in the banking sector is the promotion system by transferring employees to a better position from one city to another where the branches of the banks are located. This displacement is perceived by the employees as a burden especially if they have to leave their family and moving to a new workplace in another city. Most of the employees prefer to keep working in the same place even though the consequences are they will gain no career promotion and no compensation improvement.

The third hypothesis was about the effect of work-family support on job satisfaction. The results showed that work-family support had a positive effect on job satisfaction. This study found that working women will add more income to the family resulting in better family's financial condition and finally can minimize family conflict due to financial problems. At the end, this will lead to increased job satisfaction.

Based on research findings, it is really recommended that the management should emphasize more on extrinsic rewards like salary, bonus, and commission in order to keep their employee satisfaction toward the jobs. Good compensation system will lead to good work performance. This strategy will also affect the level of job satisfaction for work-family. In minimizing the objection or even rejection from employees to be transferred to other cities for the career promotion purposes, the company can implement a special policy such as younger retirement age which is at the age of thirty-five years old. This is possible to be executed so there are no more employees who do not want to be moved to another area.

*This paper is written with financial support from specific university research funds of Universitas Jember.*

### References

- Allen T.D., 2001, *Family-supportive work environments: The role of organization perceptions*, "Journal of Vocational Behavior", 58.
- Anderson S.E., Coffey B.S., Byerly R.T., 2002, *Formal organizational initiatives and informal workplace practices: Links to work-family conflict and job-related outcomes*, "Journal of Management", 28(6).
- Behson S.J., 2005, *The relative contribution of formal and informal organizational work-family support*, "Journal of Vocational Behavior", 66.
- Burke R.J., McKeen C.A., 1995, *Work experiences, career development, and career success of managerial and professional women*, "Journal of Social Behavior and Personality", 10.
- Frone M.R., 2003, *Work-family balance*, [In:] Quick J.C., Tetrick L.E. (Eds.), *Handbook of occupational health psychology*, Washington, DC: American Psychological Association.
- George J.M., Jones G.R., 2008, *Understanding and Managing Organizational behavior*, Fifth Edition, New Jersey: Pearson/Prentice Hall.
- Gibson J.L., Ivancevich J.M., Donnelly J.H., 1997, *Organisasi, Perilaku, Struktur, Proses*. Edisi Kedelapan, Terjemahan. Jakarta: Binarupa Aksara.
- Grace and Khalsa, 2003, *Re-recruiting Faculty and Staff: The Antidote to Today's High Attrition*, "Independent School", 62(3).
- Greenhaus J.H., Beutell N.J., 1985, *Sources of conflict between work and family roles*, "Academy of Management Review", 10.
- Greenhaus J.H., Parasuraman S., Collins K.M., 2001, *Career involvement and family involvement as moderators of relationships between work-family conflict and withdrawal from a profession*, "Journal of Occupational Health Psychology", 6.
- Judge T.A., Watanabe S., 2010, *Another look at the job satisfaction life satisfaction relationship*, "Journal of Applied Psychology", 78.
- Kreitner and Kinicki, 2006, *Organizational Behavior*, New York: McGraw Hill.
- Markiewicz D., Devine I., Kausilas D., 2000, *Friendship of men and women at work: Job Satisfaction and resource implications*, "Journal of Management Psychology", 15.
- McCracken D.M., 2002, *Winning the talent war for women: Sometimes it takes a revolution*, "Harvard Business Review", November.



- O'Donnell M.P., 2007, *Psychologically healthy workplaces*, "American Journal of Health Promotion", 21(3).
- Rutherford S., 2005, *Different Yet Equal*, [In:] Burke R.J., Mattis M.C. (Eds.), Supporting Women's Career Advancement, Cheltenham: Edward Elgar.
- Schermerhorn J.J., Hunt G., Osborn R.N., 1991, *Managing Organizational Behavior*, Fourth Edition, United States: John Wiley and Sons Inc.
- Spector P.E., 1997, *Job satisfaction: Application, assessment, causes and consequences*, Thousand Oaks, CA: Sage Publications, Inc.
- Stringer R.A., Cheloha R.S., 2003, *The power of a development plan*, "Human Resource Planning", 26(4).
- Tobing D.S.K., 2008, *Effects of Transformational Leadership on Job Satisfaction, Organizational Commitment and Employee Motivation and Performance*, PTPN II, III, IV in North Sumatra, Dissertation Graduate Program, University of Airlangga.
- Tobing D.S.K., 2009, *Pengaruh Komitmen Organizational (Organizational Commitment) dan Kepuasan Kerja (Job Satisfaction) Terhadap Kinerja Karyawan (Employee Performance) PTPN III Di Sumatera Utara*, "Jurnal Manajemen dan Kewirausahaan (Journal of Management and Entrepreneurship)", 11(1).
- Wruck K.H., 2000, *Breaking the Code of Change*, Boston: Harvard Business School Press.

#### EFEKT KOMPENSACJI, ROZWOJU ZAWODOWEGO, WSPARCIA PRACA-RODZINA NA SATYSFAKCJĘ Z PRACY

**Streszczenie:** W artykule dokonano analizy wpływu kompensacji, rozwoju zawodowego i wsparcia praca – rodzina na satysfakcję z pracy. Próbie poddano 175 pracowników zatrudnionych w bankach państwowych w Jember, Jawa Wschodnia, Indonezja. W celu sprawdzenia zaproponowanej hipotezy wykorzystana została wieloraka regresja liniowa. Wyniki potwierdziły, że kompensacja i wsparcie praca-rodzina miały znaczący wpływ na satysfakcję z pracy, a rozwój kariery nie wpływa znacząco na satysfakcję z pracy.

**Słowa kluczowe:** kompensacja, rozwój zawodowy, wsparcie praca-rodzina, satysfakcja z pracy, banki państwowe

#### 補償，職業發展，工作家庭對工作滿意度的支持的影響

**摘要：**本研究的目的是分析薪酬，職業發展和工作家庭支持對工作滿意度的影響。樣本包括在印度尼西亞東爪哇省Jember Regency的國有銀行工作的175名員工。多元線性回歸用於測試所提出的假設。結果表明，補償和工作 - 家庭支持對工作滿意度有顯著影響。另一方面，職業發展沒有顯著影響工作滿意度。

**關鍵詞：**薪酬，職業發展，工作家庭支持，工作滿意度，國有企業銀行