

New refrigerants used by heat pumps

Andrzej Grzebielec *¹

¹Warsaw University of Technology, Warsaw, Poland

Abstract

The date is inevitably approaching when refrigerants such as R407C (GWP 1774) and R410A (GWP 2088) cannot be used in newly introduced refrigeration, air conditioning and heat pump equipment. From January 1, 2020, there is a ban on placing on the market devices with refrigerants with a GWP greater than 2500, and from January 1, 2025 the limit value will be 750. Thus, devices filled with R404A (GWP 3922) have already disappeared from the primary market. Despite the anticipated changes in the short term, heat pumps with refrigerants such as R407C or R410A still dominate the sale. Devices with R134a (GWP 1430), R32 (GWP 675), R290 propane (GWP 3) or R744 carbon dioxide are sold to a lesser extent.

Keywords: heat pump, refrigerants, GWP

1 Introduction

It is commonly believed that heat pumps are used primarily for heating single-family houses or for the production of domestic hot water. And this segment is indeed the largest part of the market for this type of devices [2, 6, 7, 13, 14]. The mentioned segment has specialized in several types of devices:

- internal monoblocks for the domestic hot water production;
- internal monoblocks for space heating - often in a dual-function variant, i.e. with the possibility of producing domestic hot water;
- outdoor monoblocks for space heating;
- splits for space or individual room heating.

It is also worth mentioning the use of typical air-conditioning devices for heating rooms, such as splits and VRV systems (Variable Refrigerant Volume). However, according to the report of the PORT PC organization, while VRVs are commonly used for heating, only 10% of air conditioning splits are used for heating purposes [11, 12]. This is due to the fact that most splits are installed in apartments with a central heating system. In such a case, splits have a hard time competing with the prices of district heating. Moreover, the billing system for district heat is often designed in such a way that whatever the user does not heat his apartment, the heat will still be charged as heat supplied by district heat.

In addition to the segment of heat pumps for central heating purposes, and hot water these devices are also used for other purposes [4, 5, 15, 17, 20]:

- heat pumps used in drying;
- heat pumps used in ventilation systems for heat recovery;
- heat pumps used in large systems to generate district heat;
- as well as heat pumps used in the broadly understood industry in virtually all temperature ranges (from cryogenics to temperatures of +200°C);

*Corresponding author: E-mail address: andrzej.grzebielec@pw.edu.pl (Andrzej Grzebielec)

Figures 1 and 2 present the use of a heat pump in drying systems [3, 19]. Systems of this type can be found in household appliances, herb dryers, wood dryers or in laundries. The use of heat pumps for drying purposes significantly reduces energy consumption.

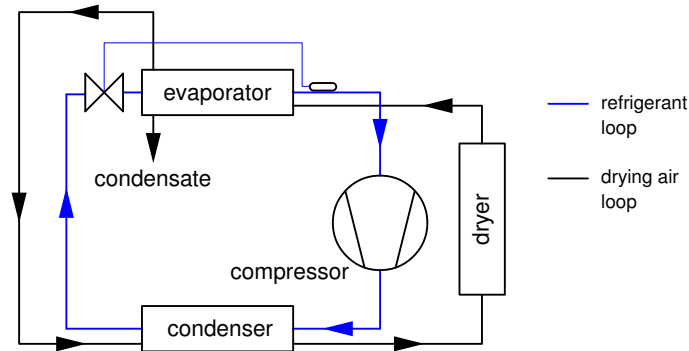

Figure 1. Closed-circuit heat pump dryer

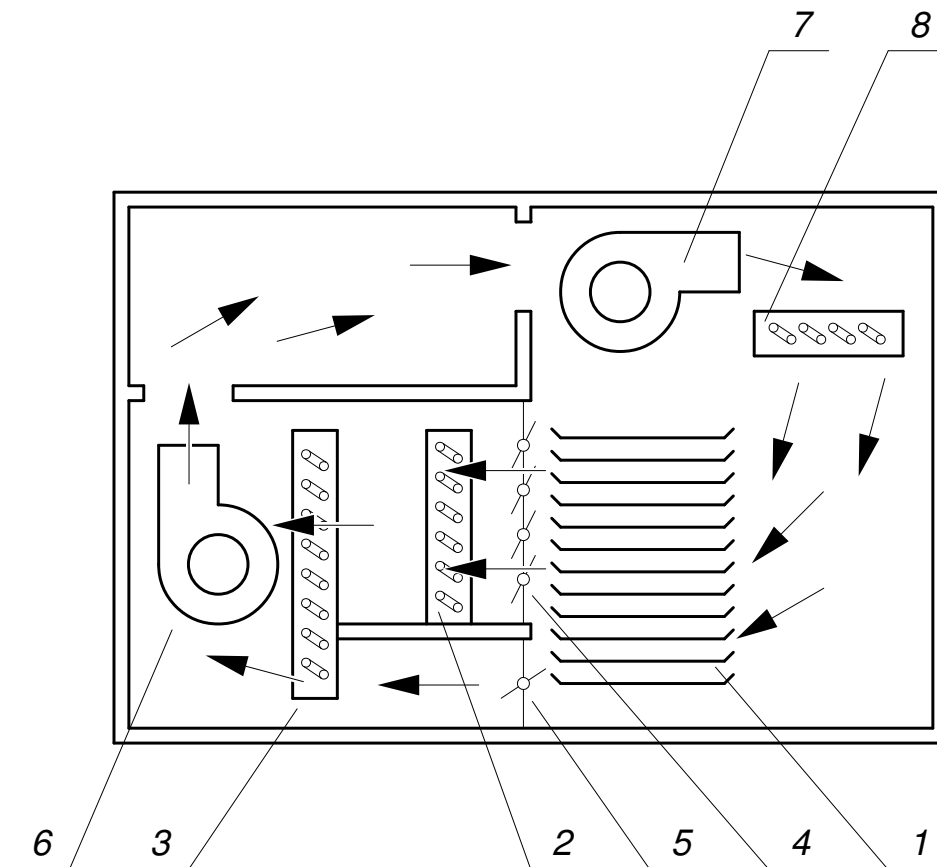

Figure 2. Heat pump usage in a closed drying chamber
 (1 - place for dried goods, 2 - heat pump evaporator, 3 - heat pump condenser, 4 - shutter controlling the amount of air flowing to the evaporator, 5 - shutter controlling the flow of air bypassing the evaporator, 6 - heat pump fan, 7 - drying chamber fan, 8 - additional heat exchanger in case the power from the condenser is insufficient)

Another application of heat pumps is their use in district heating systems. In Poland a rather unpopular solution (installations of this type are located in the Mszczonów district heating network - Fig. 3), but in Sweden, in the 1990s, 15% of heat generated in heating systems of the entire country was generated by heat pumps (Fig. 4) [1]. The increase in electricity prices and the fact that the burning of biomass has been promoted by the EU in recent years resulted in a decrease in this share. Nevertheless, it is still close to 10%.

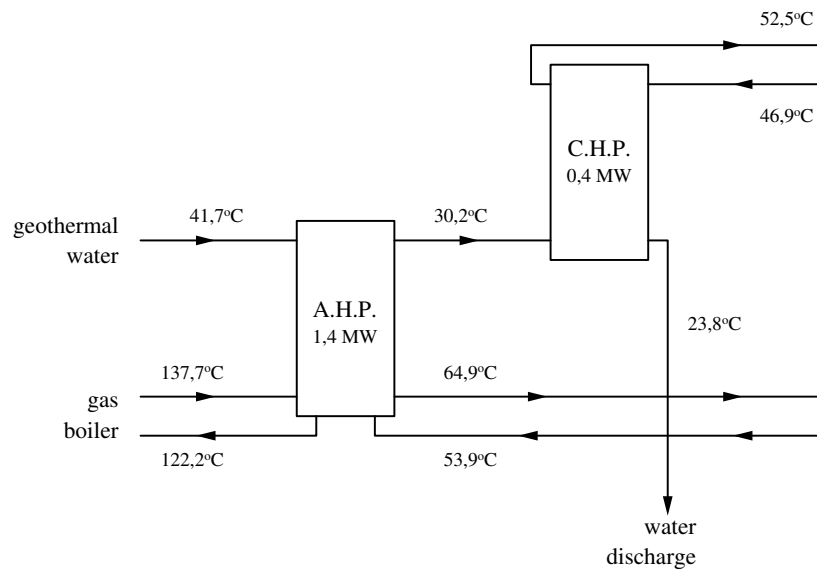

Figure 3. Heat pumps in Mszczonow district heating, A.H.P. - absorption heat pump, C.H.P. - compressor type heat pump

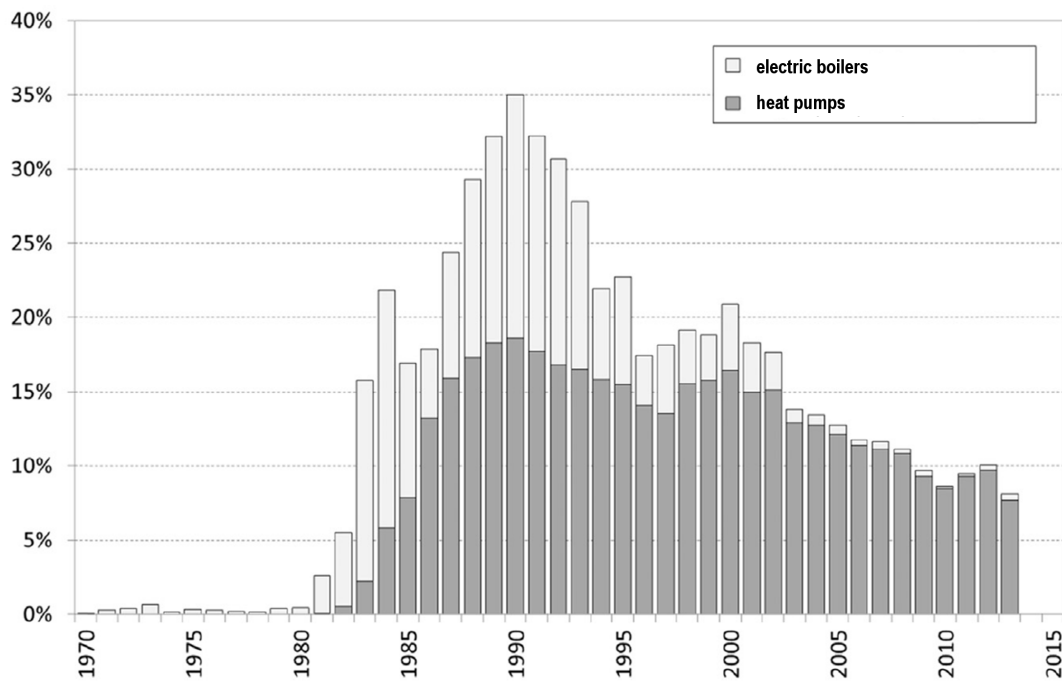

Figure 4. Share of heat pumps in the production of district heat in Sweden[1]

2 Heat pump market in Poland

Heat pumps used for domestic purposes in Poland, it is worth noting that for over a dozen years it has been characterized by dynamic growth. Diagram 5 presents the heat pump market over the last 10 years [11, 18]. It is also expected that the following years will be characterized by equally dynamic development. Compared to the German, French or Swedish, the Polish market is still far from saturated. The industry also counts on government support as part of ecological projects, such as the "Clean Air Program".

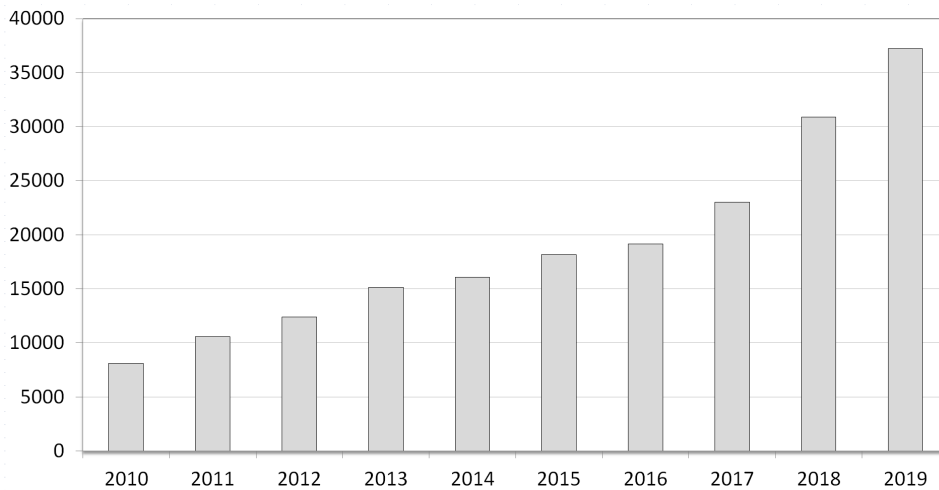

Figure 5. Number of heat pumps sold in Poland

3 Challenges for new refrigerants in heat pumps

In the introduction to the article it was mentioned that the heat pump industry is in the process of moving away from the R407C, R410A, R404A refrigerants towards factors that will meet the requirements of the latest legal regulations [16]. So what are the challenges for the new refrigerants? It is predicted that the main issues facing the ideal refrigerant in new appliances are:

- price;
- change in efficiency;
- user safety.

On the other hand, the refrigerants that most manufacturers expect to dominate the heat pump segment in the coming years are: R32, propane - R290, CO₂ - R717, R1234yf, R1233zd [10].

3.1 Price

The prices of refrigerants used so far in heat pumps (but also in refrigeration and air conditioning) increased dramatically compared to 2014. The value of refrigerants increased particularly strongly at the time when the quotas limiting the amount of new f-gases on the market started to apply. The increase in the price of refrigerants compared to 2014 at its peak was over 1000% (Figure 6). Fortunately, factor prices have been steadily falling since then, but they are still far from the values from the beginning of the 10's of the 21st. Figure 7 shows the nominal prices of the most popular refrigerants used in heat pumps in the largest European countries at the turn of 2018 and 2019.

In turn, diagram 8 shows the change in prices in nominal values in the period from 2016 to 2020. The diagram presents short-term substitutes and factors that will surely persist on the market for the next decades (R32 and R1234yf). In the case of substitutes and R32, after significant increases, we can see stabilization and a slow decline in prices, and in the case of R1234yf, the price drop is significant. It is worth recalling that at the beginning of his career, the price of the R1234yf refrigerant exceeded 200 EUR / kg.

The price of the refrigerant contained in the device when buying a new heat pump is only a few percent of the value of the device, so it is not too much limiting in their use. However, when it comes to servicing the equipment and there is a complete leakage of the refrigerant, you may find that the cost of the top-up will be a significant service cost. On the other hand, refrigerant prices are expected to continue to decline.

3.2 Change in efficiency

Due to its thermophysical properties, each refrigerant with the same external parameters (temperature of the lower heat source and temperature to which we want to heat the rooms) will achieve a different efficiency of the COP heat pump. The challenge for the new refrigerants is to achieve at least the same and preferably an even higher COP. In

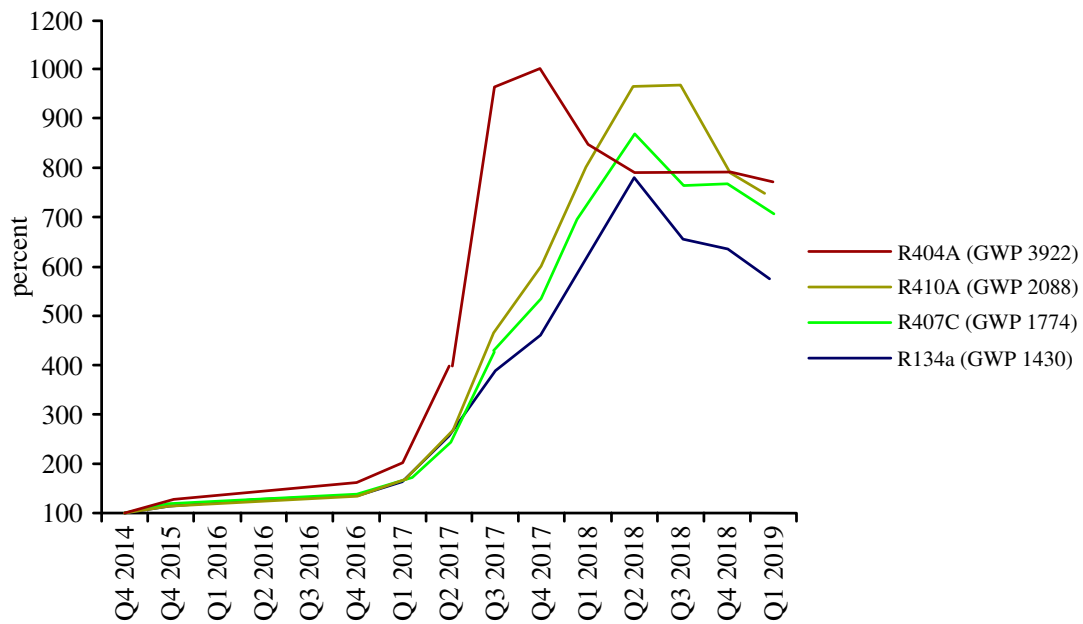

Figure 6. Changes in prices of refrigerants (2014 as 100%) [8]

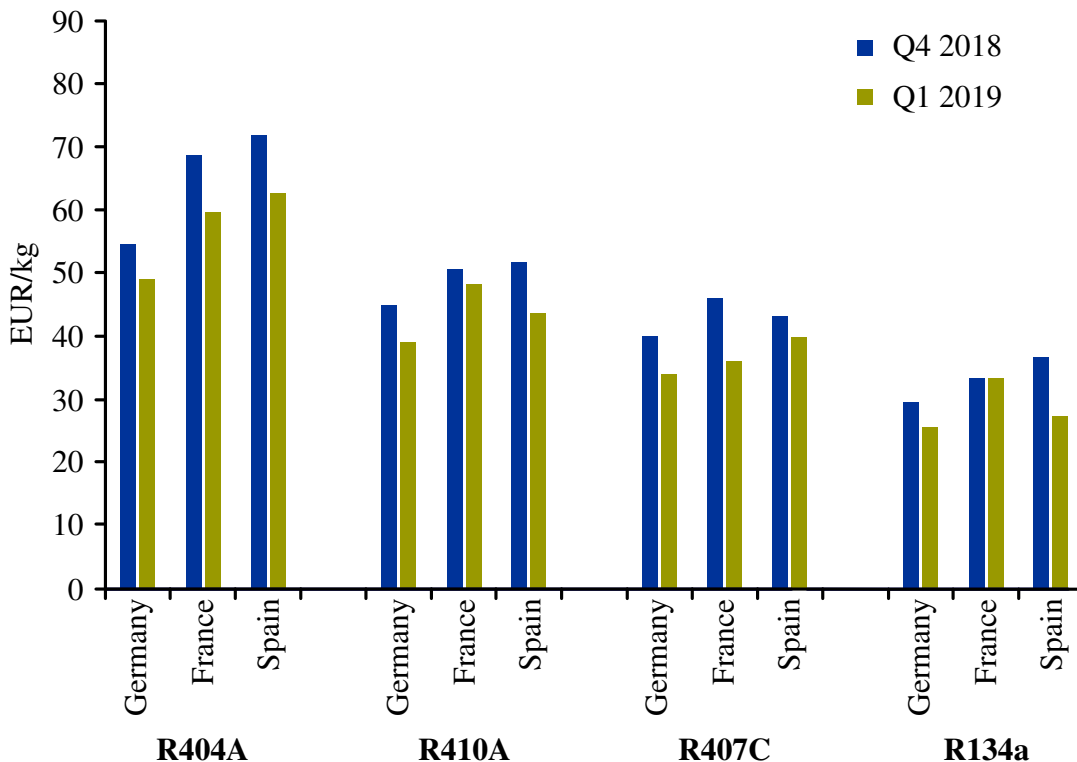

Figure 7. Prices of refrigerants in selected European countries [8]

the case of using hydrocarbons such as propane or isobutane, the COP of the device will be higher, and in the case of R32 and R1234yf, it will be comparable, so it should be stated that the new refrigerants will not increase the prices for operating heat pumps. Many installers, the change in efficiency is also associated with the replacement of one refrigerant for another in the existing equipment. It is worth noting that heat pumps operate so flawlessly that it is expected to be a marginal issue. However, in such a case, it should be noted that when replacing one refrigerant with another, the cooling capacity will also change, and in principle, in all cases, this capacity will decrease.

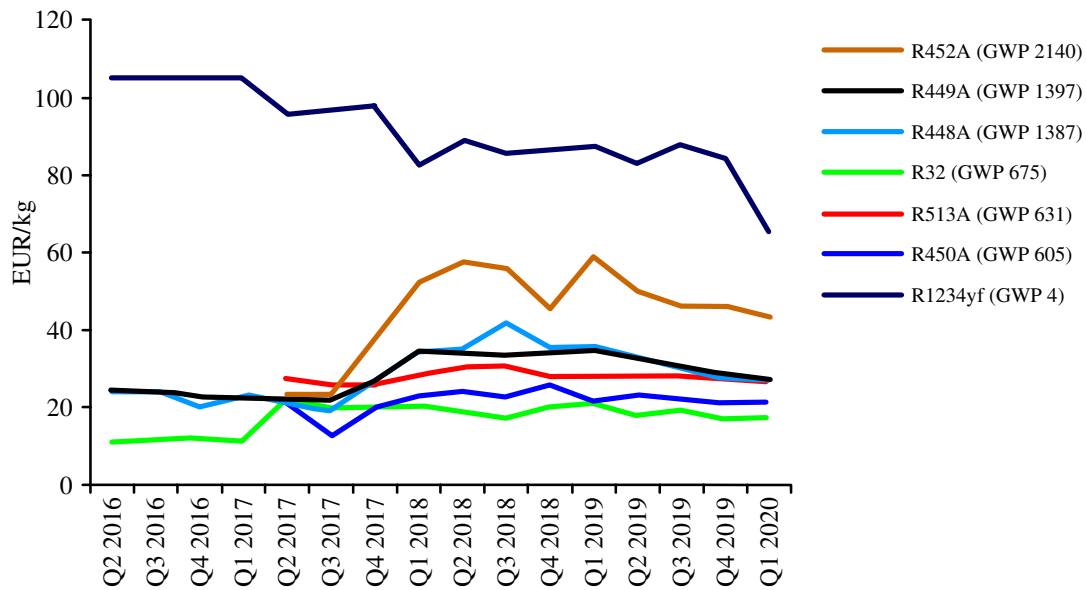

Figure 8. Refrigerant prices [9]

3.3 Safety

Since, as stated in previous chapters, the new refrigerants will improve COP and not affect the price of the device, why are they no longer widely used? Well, for many years, the overriding idea of building heat pumps, but also refrigeration devices, was the safety of use, which made CFC and HCFC refrigerants so popular. They are non-toxic and non-flammable. On the other hand, the alternative refrigerants discussed in this article do not meet all safety requirements. Of course, you should not immediately state that their use will increase accidents and significantly increase the risk for users. Appropriate design, assembly, and then appropriate servicing and use allow these devices to work safely.

At this point, two threats can be identified. One is high pressure - this is especially true for R744 carbon dioxide. However, this threat is reduced by using materials and system components adapted to this pressure level. CO₂ devices can therefore be operated exactly like devices with current refrigerants.

The second risk is the flammability of the refrigerants. Flammable working fluids include hydrocarbons: propane, isobutane and propylene, but also refrigerants such as R32 or some HFO refrigerants. At the same time, it should be remembered that R32 and HFO factors belong to the A2L safety group - i.e. their concentration must be much higher (than hydrocarbons) for ignition to occur. In practice, this means that the system can contain much more flammable refrigerant R32, HFO than propane or isobutane.

Due to the regulations in force, at present it is not possible to install heat pumps filled with propane or isobutane in small boiler rooms. However, there are no contraindications for R32 or HFO agents.

4 Summary

A review of heat pump manufacturers' offers shows that market changes are very slow when it comes to introducing new refrigerants. Most manufacturers still offer heat pumps that work with refrigerants such as R407C, R410A or R134a. Although manufacturers are aware that the offer must change, really few offer devices with alternative factors. You can find R32 heat pumps in all types of heat pumps, and external monoblocks operating on R290 (propane). These two refrigerants seem to dominate the heat pump market. This is mainly due to the prices of these factors, as well as the successes they achieved in the comfort air conditioning segment. Most new split air conditioners contain R32, and there are R290 propane air conditioners. However, the space in which the AC 290 indoor air conditioning unit is located is definitely larger than the space of the boiler room, in which heat pumps are most often placed - and thus the air conditioning systems can be filled with more propane.

The rest of the refrigerants presented as alternatives to the refrigerants currently used are most likely to be used

only under specific conditions. For example, R744 will be used in heat pumps, which will have the task of heating water from very low to very high temperature, and HFO agents will be used mainly in district heat installations.

References

1. Averfalka, H. Large heat pumps in Swedish district heating systems. *Renewable and Sustainable Energy Reviews* **79**, 1275–1284. ISSN: 1364-0321 (2017).
2. Grzebielec, A. *Efektywność pompy ciepła w zależności od temperatury dolnego źródła ciepła* in. XLII Dni Chłodnictwa (Poznań, 2010).
3. Grzebielec, A. Możliwości zastosowania pomp ciepła w procesach suszenia. *Chłodnictwo* **48**, 18–20. ISSN: 0009-4919 (2013).
4. Grzebielec, A. *Długoterminowe magazynowanie energii w złożach adsorpcyjnych* in. 50. Dni Chłodnictwa (Poznań, 2018), 115–120.
5. Grzebielec, A. & Ociepa, M. *Wykorzystanie sztucznych sieci neuronowych do sterowania powietrznymi pompami ciepła* in. XLVII Dni Chłodnictwa (2015), 75–83.
6. Grzebielec, A. & Ociepa, M. Pompy ciepła a prawo w wybranych krajach Unii Europejskiej. *Chłodnictwo* **51**, 10–14. ISSN: 0009-4919 (2016).
7. Grzebielec, A. & Wrzaszcz, P. Analiza opłacalności ogrzewania budynków pompą ciepła typu powietrze/woda na podstawie pomiarów eksploatacyjnych. *Chłodnictwo* **50**, 16–20. ISSN: 0009-4919 (4-5 2015).
8. *HFC refrigerant prices continue to fall* <https://www.coolingpost.com/world-news/hfc-refrigerant-prices-continue-to-fall/>.
9. *HFC refrigerant prices stabilise* <https://www.coolingpost.com/world-news/hfc-refrigerant-prices-stabilise/>.
10. Jania, J. Opinie producentów. Jakie czynniki chłodnicze do sprężarkowych pomp ciepła? *Chłodnictwo and Klimatyzacja (wydanie specjalne)*, 16–20. ISSN: 1425-9796 (2019–2020).
11. Lachman, P. *Rynek pomp ciepła w Polsce w latach 2010–2018. Perspektywy rozwoju rynku pomp ciepła do 2030 roku. Raport rynkowy PORT PC: Pompy Ciepła 2019* Kraków: PORT PC, 2019.
12. Lachman, P. Czy propan to przyszłość pomp ciepła? *Chłodnictwo and Klimatyzacja (wydanie specjalne pompy ciepła)*, 14–15. ISSN: 1425-9796 (2019–2020).
13. Nowak, T. *Large scale heat pumps in Europe. 16 examples of realized and successful projects* Brussels: EHPA, 2020.
14. Obstawski, P. Kierunki rozwoju czynników chłodniczych do sprężarkowych pomp ciepła. *Chłodnictwo and Klimatyzacja (wydanie specjalne pompy ciepła)*, 4–7. ISSN: 1425-9796 (2019–2020).
15. Popovski, E. *et al.* The role and costs of large-scale heat pumps in decarbonising existing district heating networks – A case study for the city of Herten in Germany. *Energy* **180**, 918–933. ISSN: 0360-5442 (2019).
16. *Rozporządzenie Parlamentu Europejskiego i Rady (UE) nr 517/2014 z dnia 16 kwietnia 2014 r. w sprawie fluorowanych gazów cieplarnianych i uchylecia rozporządzenia (WE) nr 842/2006* 2006.
17. Ruciński, A., Rusowicz, A. & Grzebielec, A. *Gas engine driven heat pump – characteristics, analysis of applications in buildings energy systems* in. 9th International Conference. Environmental Engineering (Vilnius, 2014).
18. *Stats.ehpa: Heat pump sales overview (Poland)* http://stats.ehpa.org/hp_sales/story_sales/.
19. Tajudin, N. H. A., Tasirin, S. M., Ang, W. L., Rosli, M. I. & Lim, L. C. Comparison of drying kinetics and product quality from convective heat pump and solar drying of Roselle calyx. *Food and Bioprocess Processing* **118**, 40–49. ISSN: 0960-3085 (2019).
20. Zhang, H., Zhou, L., Huang, X. & Zhang, X. Decarbonizing a large City's heating system using heat pumps: A case study of Beijing. *Energy* **186**, 115820. ISSN: 0360-5442 (2019).