

<https://doi.org/10.32056/KOMAG2021.4.1>

## Mobile working platform unit as a mean for improvement of safety and convenience of emergency shaft works

Received: 08.07.2021

Accepted: 26.08.2021

Published online: 29.12.2021


### Author's affiliations and addresses:

<sup>1</sup> AGH University of Science and Technology, Faculty of Civil Engineering and Resource Management, Department of Mining Engineering, al. Mickiewicza 30, 30-059 Krakow, Poland

<sup>2</sup> Department of Theoretical and Structural Mechanics, Dnipro National University of Railway Transport named after Academician V. Lazaryan, Lazaryan St. 2, 49010, Dnipro, Ukraine

### \* Correspondence:

e-mail: pkamin@agh.edu.pl

Piotr MAŁKOWSKI <sup>1</sup>, Paweł KAMIŃSKI <sup>1\*</sup>, Larysa NEDUZHA <sup>2</sup>

### Abstract:

A level of mine safety is related directly to the condition of its shafts. Thus regular monitoring and maintenance of shaft lining and equipment is vital. However such works are always hard and dangerous, as they are conducted from conveyances. Working platforms are a significant improvement in case of emergency shaft works. However, they need some extremely precious time for assembly. An idea of pull out working platform combines safety and convenience of typical working platform with short time of its installation. Following work presents the idea and construction of the mobile working platform unit, which is a solution for improvement of shaft works conducted from the compartment of the conveyance, as the platform uses cage for transport and operation.

Keywords: shaft works, mine shaft, shaft maintenance, working platform, work safety



## 1. Introduction

Mine shafts, as main mine workings, are crucial for the safety of the whole mine in almost every aspect – from ventilation, through reliability of man and material transport, to providing an escape route for miners [1-6]. Condition of shaft lining, hoisting system and other equipment should be constantly monitored and all of failures or malfunctions should be immediately repaired. Lack of proper monitoring of the mine shaft and its elements can lead to serious accidents or even catastrophes, as it was in shaft no. V of the Knurów department of the Knurów-Szczygłowiec colliery [1, 5, 7-9].

Advanced age of most of Polish mine shafts makes the issue of mine shaft monitoring even more important [1, 10]. However, Polish regulations on mine shaft elements monitoring are not precise. Moreover, the process of the monitoring in such old workings might be hard itself. The development of mobile monitoring devices can positively affect the quality of mine shaft monitoring, despite of the high investment cost of these solutions. Further development of mobile monitoring solution is to be expected [5].

Currently the mine shaft monitoring comes down to periodical destructive and non-destructive testing conducted by experts. However, the process of shaft lining testing might be complicated, as it is conducted from the conveyance, which sometimes makes it difficult to reach the lining. It is also required to stop regular operation of the shaft hoisting system for the time of conducting the test. Periodical character of the tests can also result in late information of potential damages or failures [1, 5, 11-16].

The situation of emergency and maintenance works in mine shafts, such as repairs of the lining, pipelines or cables, is similar. These elements are accessible only from the conveyance or working platform that has to be built in the shaft or on the conveyance construction. The most convenient way of conducting the shaft works is to build a suspended working platform. However such solutions are extremely expensive and complex constructions and require a long period of time for their design and assembly. For these purposes they are used only in case of shaft sinking, equipping or very complex shaft modernization. In case of emergency or maintenance works, application of such constructions is not economically justified [3-4, 17-21]. Working platforms assembled to conveyances construction are also used. They were an inspiration for the pull out platform and they are presented in following section.

Another modern solution combining safety and convenience of suspended working platform with mobility of the conveyance is the special-purposes conveyance that was used by Shaft Sinking Company (PBSz SA) in the 1-Bzie shaft of the Jastrzębie-Bzie colliery [22-24].

The solution of the pull out working platform described in this work was used in the shaft no. II of Borynia department of the Borynia-Zofiówka coal mine to improve repair works. This shaft is equipped with four-compartment conveyances, guided using stiff steel guides [25].

## 2. Existing constructions of shaft working platforms

Working platforms used in shafts of underground mines are designed to provide access to the shaft lining and equipment, such as pipelines or cables. They are assembled to the top transom of the conveyance, to the floor of cage's compartments or to the conveyance's sidewalls. Shaft working platforms have to provide proper level of safety for people using them and possibly the shortest time of their assembly and disassembly. Every element of the working platform which exceeds the conveyance's outline has to be transported in the cage and manually assembled. A working platform is usually assembled at the level, where shaft works are to be conducted, in extreme conditions of the cage suspended at great height.

In case of the shaft stoppage ongoing for at least few days (which is a very rare situation), permanent platforms are installed. In such case, constructions used in civil engineering are used, built or suspended on the shaft buntons. It can be spotted in shafts where hoisting system operation is suspended for a long period of time, e.g. in case of repair of the lining in large range.

For purpose of testing and carrying out works in the operating shaft, stiff platforms assembled to the top transom of the conveyance, constructed inside the cage or swing platforms installed to other elements of the cage's construction are used.

Stiff platform installed on the top transom of the cage usually consists of the rigid frame assembled with screw to elements of the construction of the cage's top transom and the actual platforms made of

steel sheet and assembled to beams, which are installed on the frame using pins. To provide safety for people working on the platform, it is equipped with barriers and an overhead protection. Platforms with beams and protections are disassembled after every working shift, while the frame is usually disassembled after the end of the works.

Platform constructed inside the cage is usually made of steel or wooden beams, installed parallelly to the conveyance's axis. The most popular construction of such platforms comprises thick wooden boards blocked with transverse steel beams, assembled to the cage's construction with screws.

Swing platform is usually a steel construction installed from the inside of the cage, with the possibility of rotation around the point of its assembly. The construction of swing platform is based on steel cables lowered along the cage. Platforms are assembled to the cables. The construction of the swing platform allows to work on even three levels simultaneously, as well as quick assembly and disassembly of the platform. However, the construction is a subject of big torque, which makes stabilizing the platform and thus providing safety for people working on it a real issue.

Time for tests, repairs and modernizations of the shaft elements is limited, especially in the shaft with operating hoisting system. Shafts are usually available for contractors only on single shifts on weekends or holiday. The time for which the hoist is blocked with the cage at the level of where the shaft works are to be conducted is spent on: loading of the platform's elements and its assembly together with all protections, actual shaft works (such as lining repair), disassembly of the platform and unloading of its elements. The issue is the long time of the preparatory actions (assembly and disassembly of the platform). The aim is to shorten their time, to make the shaft works more effective with providing proper level of safety.

The solution for reducing the time of assembly and disassembly of the working platform is application of constructions which allows to pull out or unfold platform's elements installed in a unit, which is placed inside the cage.

German patent DE29908954U1 [26] presents working platform based on a lift. Elements of the working platform are located in the corpus of the device and they can be pull out for purpose of increasing the area of the platform surface. These elements are telescopically connected. Proper stiffness of the construction is provided by side beams, which are pulled out together with the main element of the platform. They also play a role of side barrier. Movable elements are connected with the device corpus with telescopic rails. However, the method of attachment does not provide sufficient durability for high payloads and allows for small enlargement of the working platform area.

French patent FR2830557 [27] presents a solution of working platform, which allows to increase the width of the working platform area. Platform extensions are connected with the main platform with vertical barrier element. To increase the platform width protective barrier is disconnected and the extension is rotated around its axis, moving along the arch from its idle position to outside of the platform. However, this construction of the working platform cannot be used in case of restricted space, which makes it impossible to move the extension.

Patent WO2006052131 [28] presents a sliding working platform, which is an element of a lift. Two guides made of C-profile are attached to the permanent platform along its longer sides. Movable platforms are assembled to the guides and they can be moved to extend the permanent platform on its both sides. The method of attachment does not provide sufficient support for high payloads and it is a source of high forces acting on the moveable platforms.

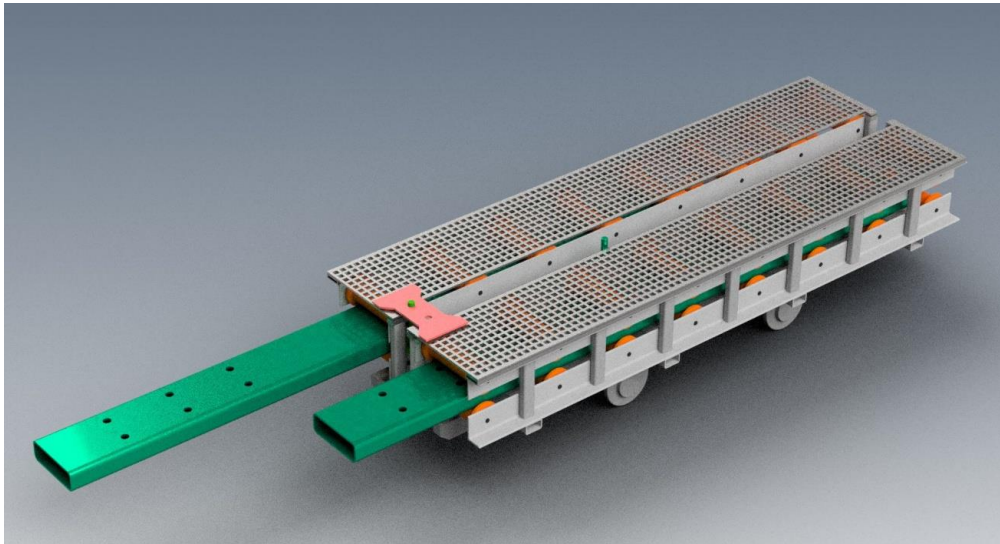
Krause company offers so-called telescopic working platform, construction of which allows to telescopically extend its length from 1.75 up to 3.50 m. It consists of closed profile containing moveable element, which allows for the platform extension and together with dedicated accessories creates a complete working platform. It is designed for maximum working height of 3.0 m with payload of 200 kg. It is used to access objects vertically and it requires support construction on both sides of the platform. Its construction results in relatively small payload of the platform.

Solutions for extending the working platform presented above cannot be used in a mine shaft, because they do not provide sufficient payload, range, safety as well as convenience in transport or assembly in difficult conditions. However, they became an impulse for design of the device that would help to improve safety and convenience of conducting shaft works.

### 3. Mobile working platform unit

The idea behind the invention of the mobile working platform unit was to design a light and easy to move construction of a working platform. The aim was to develop a device equipped with moveable elements that creates working platforms of high durability and providing high level of safety. The mobile working platform unit can be transported in a mining cage and operate in the shaft from the conveyance. Its elements are easy to assemble, disassemble and transport.

Mobile working platform unit is designed to play a role of a working platform for emergency and maintenance shaft works. It consists of pull out platform element assembled to a corpus, which is equipped with undercarriage. A view of the platform is presented in Fig. 1.



**Fig. 1.** A view of the mobile working platform unit for shaft works

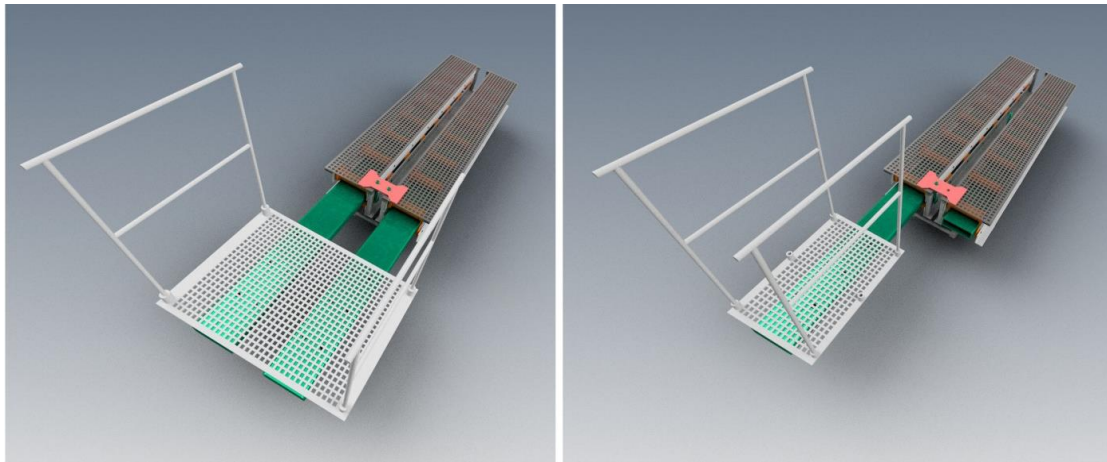
The mobile working platform unit, according to patent [25] comprises one or two corpuses, each of them constructed of four beams: two top and two bottom, connected permanently and two roller guides: top and bottom, permanently fixed to the corpus. A moveable bridge is assembled between two roller guides. Permanent working platform is installed on the top of the device's corpus. The corpus is permanently fixed to the undercarriage.

The mobile working platform is connected to the construction of a conveyance using technological holes in the beams. Roller guides are groups of spool-like rollers, assembled rotarily in the corpus' beams, both top and bottom.

The moveable bridge, which is a closed-profile beam, is assembled between bottom and top roller guides, which allows to easily move the bridge and to stabilize it in a safe and reliable manner. There are symmetrical pairs of mounting holes evenly spaced on the bridge. Mounting holes allow to lock longitudinal motion of the bridge. The corpus of the mobile working platform unit is covered with permanent working platform, made of steel grate with square eyelets.

The key feature of the device is the moveable working platform which is installed on the bridge exceeding the outline of the device's corpus and thus the outline of the cage. It is made of steel grate, the same as the permanent platform. Elements of the moveable platform are assembled using pins, permanently fixed to the platform's element. A distance between the surfaces of the platform and the bridge is fixed using sleeve-like spacers used with the pins. Pins' spacing is equal to the spacing of the mounting holes on the moveable bridge. Pins placed in the mounting holes lock the motion of the moveable platform. Every platform used with the mobile working platform unit has to be equipped with an even number of pins and not less than four. Moveable platforms are also equipped with protective barrier segments and optionally with an overhead protection. A view of the platform unit equipped with different types of moveable platforms is shown in Fig. 2.



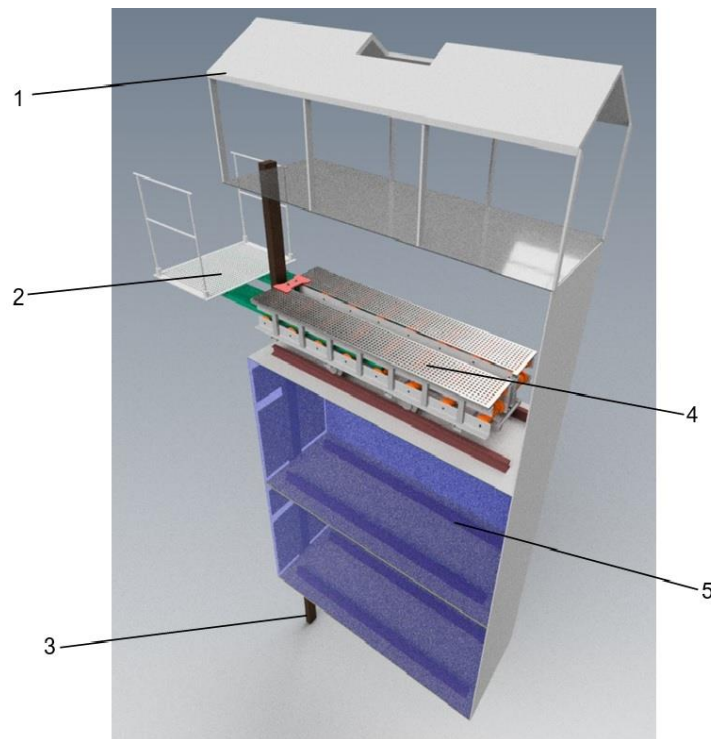


**Fig. 2.** A view of the mobile working platform unit equipped with different types of moveable platforms

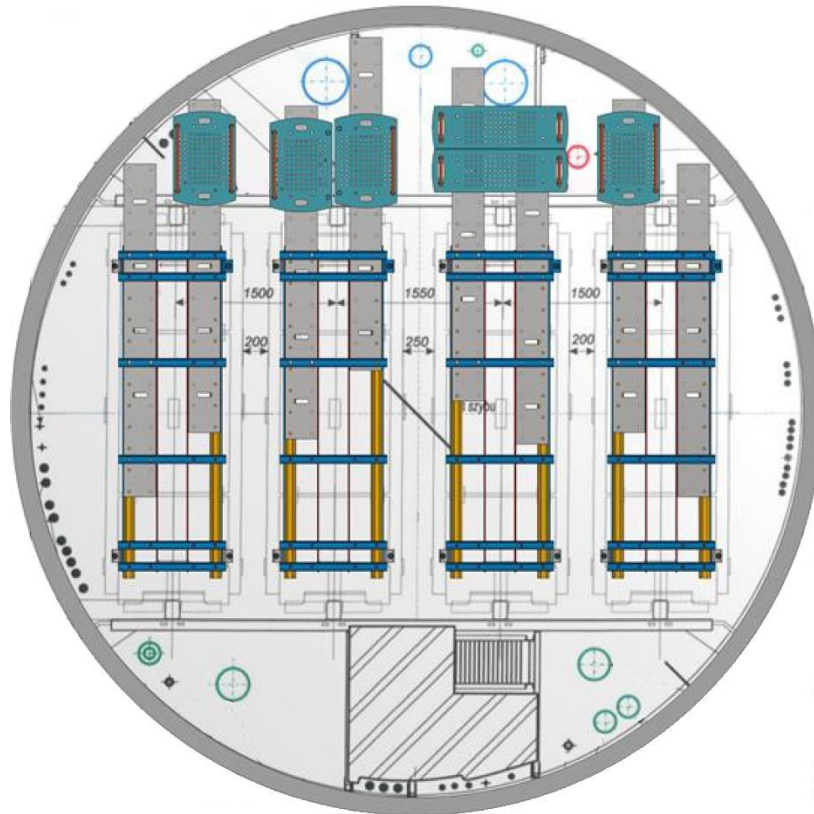
The permanent platform is connected with the moveable bridge using minimum two profile overlays, made of a flat bar, equipped with pins fixed at right angles to its surface. The overlays, connecting platform's grate and bridge's mounting holes are a mechanical lock, preventing bridge's longitudinal motion.

The corpus of the mobile working platform unit is fixed to a undercarriage frame. The undercarriage comprises at least two single axis or one two-axle cart. The parameters of the carts (axle's width and wheel size) have to be suited to the parameters of the mine's rail system.

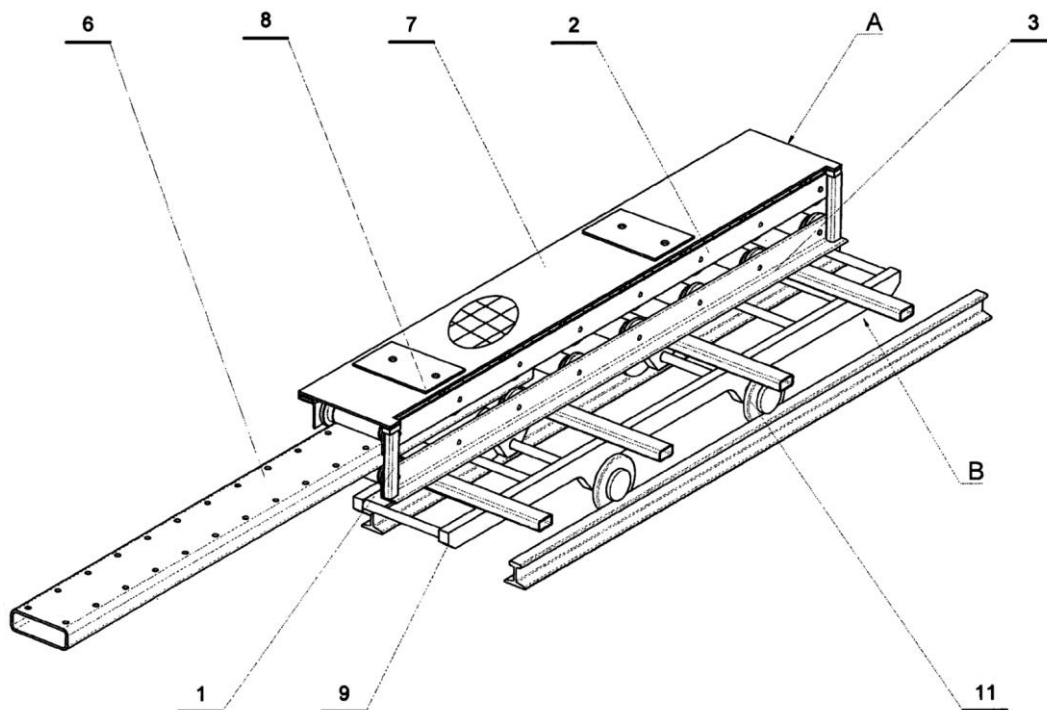
Dimensions of the mobile working platform unit are suited to the dimensions of the conveyance in which the platform is to be used. Fig. 3 presents a view of the mobile working platform unit placed in the conveyance. Fig. 4 pictures an example of application of the device in a mine shaft equipped with four cages. Design of the mobile working platform unit is shown in Fig. 5 and 6.



**Fig. 3.** The mobile working platform unit in a conveyance:  
1 – cage's overhead protection, 2 – moveable platform, 3 – guide, 4 – corpus, 5 -cage

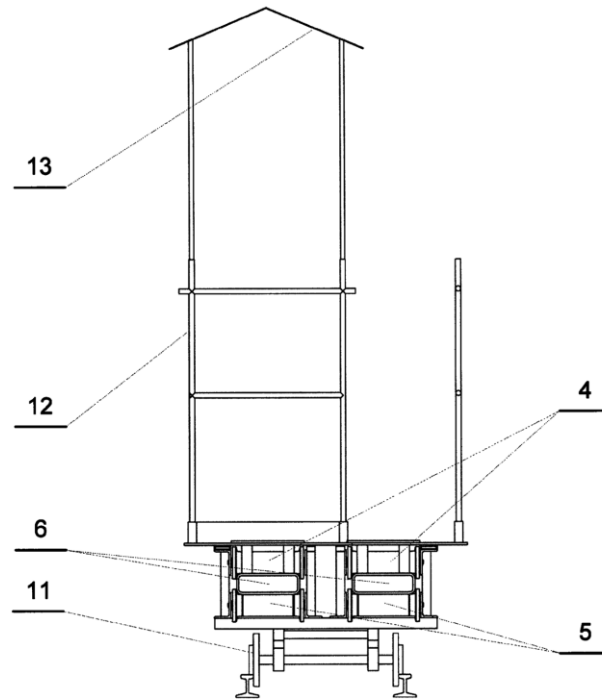


**Fig. 4.** An example of possible application of mobile working platform units with different types of moveable platforms in a mine shaft equipped with four cages



**Fig. 5.** Design of the mobile working platform unit:

A – corpus, B – undercarriage, 1 – corpus connectors, 2 – corpus' top beam, 3 – corpus' bottom beam, 6 – moveable bridge, 7 – permanent platform, 8 – profile overlay, 9 – undercarriage frame, 11 – cart



**Fig. 6.** Design of the mobile working platform unit:

4 – top roller guide, 5 – bottom roller guide, 6 – moveable bridge, 11 – cart, 12 – protective barriers, 13 – overhead protection

As it can be seen in Fig. 4, the mobile working platform unit provides access to the area of the shaft which depends on the configuration of the conveyances installed in the shaft. Moveable platform can be “pulled out” in only one direction, thus the accessible area is limited. However, it is not an issue in terms of planned applicability of the device, as it was designed to improve level of safety and convenience of works, which are conducted from the inside of the cage’s compartment. Works on the other sides of the cage are usually conducted using top transom of the cage and major repairs and modernizations of shafts and their equipment requires application of standard suspended working platforms.

Working platforms for mining engineering and for shaft works in particular, has to provide proper level of safety for working people and have relatively high payload. This is the reason why some of the constructions of working platform used in civil engineering cannot be applied in mine shafts. To prove that the mobile working platform unit meets the requirements of safety and payload, numerical simulations were conducted to analyse its behaviour. Values of bending stress and displacement obtained in the simulations confirmed that the platform provides proper level of safety. Results of the simulations are shown in Fig. 7 and 8.

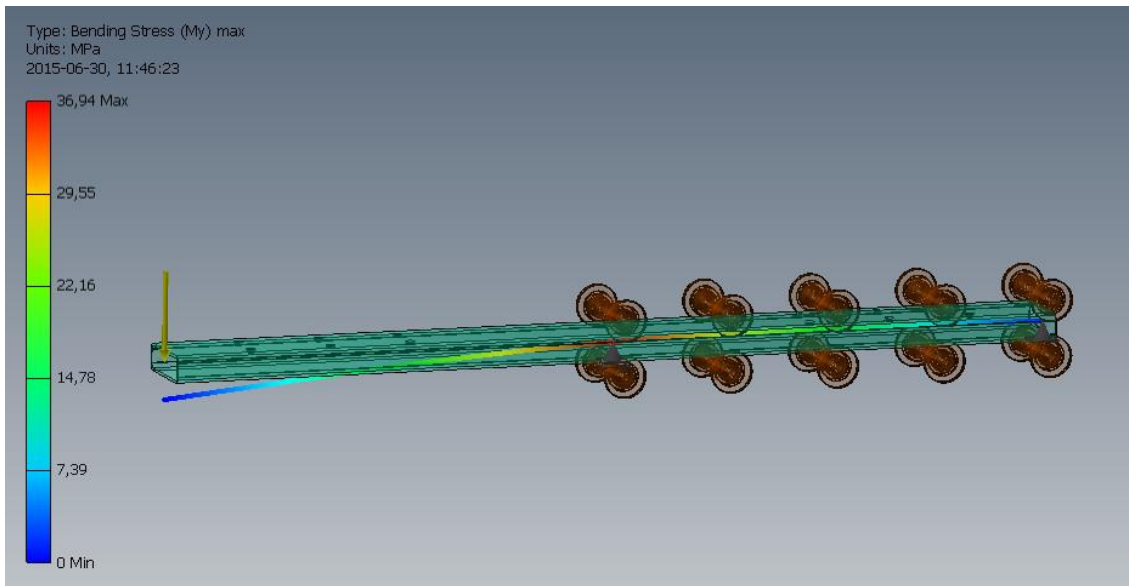


Fig. 7. Bending stress map

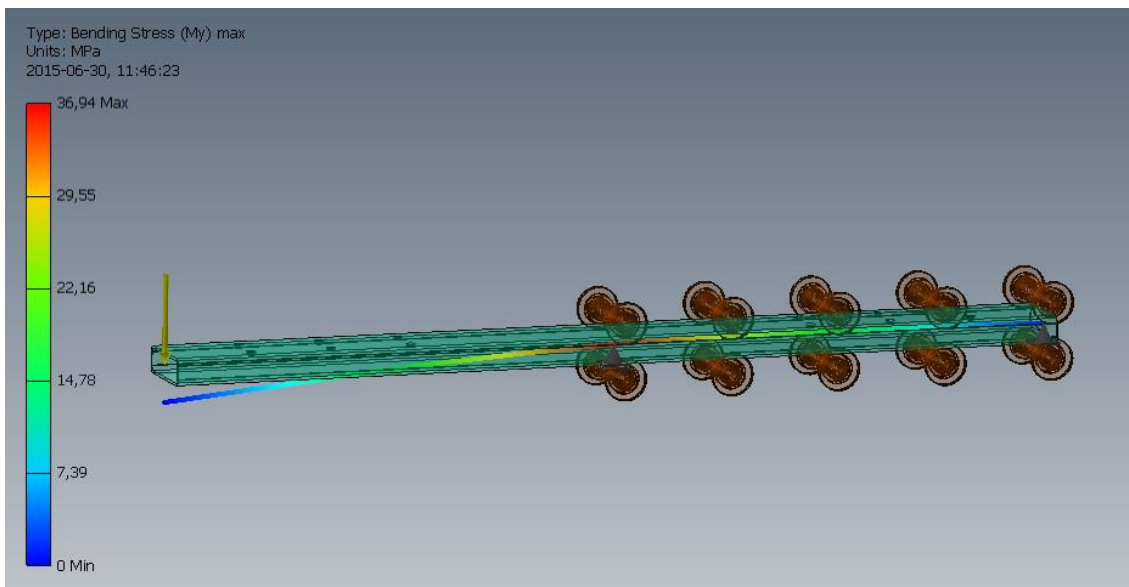


Fig. 8. Displacement map

#### 4. Summary

Proper maintenance of the lining and equipment of mine shafts is crucial for safety of the whole mine. The problem is that all of the shaft works, including monitoring of shaft elements, maintenance and emergency works, require stoppage of the shaft operation and application of working platform of special construction. Moreover, shaft works are difficult and dangerous. Thus, the key features of working platforms are high level of safety and short time of their assembly and disassembly. Analysis of this factors was an impact for the design of the mobile working platform unit for shaft works.

The advantage of the mobile working platform unit is minimization of time required for assembly and disassembly of the construction of a platform exceeding the outline of the conveyance. The invention allows to conduct maintenance work of shaft lining, equipment or installations in a safe manner. The moveable bridge and moveable platform equipped with barriers and optionally the overhead protection significantly improves safety of people working in the shaft. The unit ensures full stability of the pull-out bridge construction by locking the motion of both the bridge and the corpus,



as the unit is fixed to the construction of the conveyance. The mobile working platform unit also plays a role of transport platform for all of its elements for the time of their transport in the cage.

The platform cannot be used for all types of shaft works, as accessible of the shaft is limited, so it cannot be a replacement for all types of shaft working platforms, like typical suspended working platforms. Also it can be used only for minor repairs of shaft lining or equipment. However, the platform was designed to improve shaft works conducted using working platforms installed in the cage's compartments and it meets designed requirements.

Presented construction of the working platform might positively affect the safety and effectiveness of conducting shaft works, including its monitoring, maintenance and emergency works. Thus it can improve economic score of such ventures or even help to increase level safety of the whole mine.

## 5. Patents

Małkowski P., Kamiński P. *Mobile working platform unit*, Polish patent PL236729B1, 08.02.2021

## References

- [1] Niedbalski Z., Małkowski P.: Difficulties in maintaining shaft lining – testing methods and repair methods – a case study, E3S Web of Conferences; ISSN 2267-1242. 2020 vol. 201 art. no. 01016, s. 1–10
- [2] Majcherczyk T., Niedbalski Z., Wałach D.: Shaft lining and rock mass reinforcement in difficult geological conditions, in: 23rd World Mining Congress held in conjunction with ISARC 2013 (International Symposium on Automation and Robotics in the Construction and Mining Industries): August 11–15 2013, Montreal, Canadian Institute of Mining, Metallurgy and Petroleum
- [3] Lecomte A., Munos Niharra A.: Handbook to best practices for mine shafts protection, Research Programme of the Research Fund for Coal and Steel Coal RTD, European Commission, 2013
- [4] Czaja P., Kamiński P.: Wybrane zagadnienia technik i technologii głębiania szybów (Selected issues of shaft sinking technics and technologies), Szkoła Eksploatacji Podziemnej, Kraków 2016
- [5] Kalinowski P., Długosz O., Kamiński P.: Digital Twin of the Mining Shaft and Hoisting System as an Opportunity to Improve the Management Processes of Shaft Infrastructure Diagnostics and Monitoring, Data Visualization, IntechOpen 2021, DOI: 10.5772/intechopen.96193
- [6] de la Vergne J.: Hard Rock Miner's Handbook. 3rd Edition. McIntosh Engineering. North Bay. Ontario, Canada 2003
- [7] Sun Q., Ma F., Guo J., Li G., Feng X.: Deformation Failure Mechanism of Deep Vertical Shaft in Jinchuan Mining Area. Sustainability. 2020, 12. 10.3390/su12062226
- [8] Zhao H., Ma F.S., X, J.M., Zhang Y.M., Guo, J.: Shaft deformation and failure due to rock mass movement induced by underground backfill mining of a metal mine. Yantu Gongcheng Xuebao/Chinese Journal of Geotechnical Engineering. 34. 340-348, 2012
- [9] Ma F., Deng Q., Cunningham D., Yuan R., Zhao H.: Vertical shaft collapse at the Jinchuan Nickel Mine, Gansu Province, China: Analysis of contributing factors and causal mechanisms. Environ. Earth Sci. 2013, 69, 21–28. doi:10.1007/s12665-012-1930-6
- [10] Ozturk H., Guler E.: A methodology for lining design of circular mine shafts in different rock masses. International Journal of Mining Science and Technology, 2016 26. 10.1016/j.ijmst.2016.05.049
- [11] Majcherczyk T., Małkowski P., Witosiński J., Lubryka M. Makroskopowa i laboratoryjna ocena stanu obudowy wyrobiska szybowego (Macroscopic and laboratory assessment of the shaft lining) in: Geotechnika i budownictwo specjalne 2000: XXIII Zimowa Szkoła Mechaniki Górniczej: Bukowina Tatrzańska, 13–17 marca 2000 / [red. Danuta Flisiak] ; Katedra Geomechaniki Górniczej i Geotechniki AGH, Kraków : Wydawnictwo KGGiG AGH, 2000
- [12] Borowiec W., Józwick M., Machowski Z.: Application results of modern instruments in control survey of mining shafts. The Mine Surveying in the Socialist Countries Vol. 10, Ostrava 1986
- [13] Kleta H.: Założenia systemu monitorowania szybów górniczych w świetle wybranych uszkodzeń obudowy szybów (Assumptions for mine shaft monitoring system in terms of selected shaft lining failures), Systemy Wspomagania w Inżynierii Produkcji, 2017/6

- [14] Stasica J.: Nowoczesne metody badań i oceny stanu technicznego obudów szybów górniczych (Modern methods of mine shaft lining tests and assessment). Zeszyty Naukowe Instytutu Gospodarki Surowcami Mineralnymi i Energią PAN, 2017, (101), 85-99
- [15] Bock S. 2006. Metody badań wytrzymałościowych obudowy szybów kopalnianych (Methods of mine shaft lining strength tests). Prace naukowe Głównego Instytutu Górnicztwa (GIG) – Kwartalnik Górnictwo i Środowisko nr 3, s. 23–41
- [16] Stasica J., Rak Z. 2016. Badanie stanu obudowy szybów górniczych – studium przypadku (Mine shaft lining evaluation – case study). Przegląd Górniczy nr 72(12), s. 84–92
- [17] Kamiński P.: Polish experience in shaft deepening and mining shaft hoists elongation, Mining Techniques-Past, Present and Future, InTech 2020
- [18] Pypno M., Mika J., Ratuszny K.: Pomost wiszący do interwencyjnych robót szybowych (Suspended working platform for emergency shaft works), Art Of Mining, Katowice 2013, nr 10 -12, s. 28 – 35
- [19] Czaja P., Kamiński P., Olszewski J., Bulenda P.: Polish experience in shaft deepening and mining shaft hoists extending on the example of the Leon shaft IV in the Rydułtowy mine, in: World Mining Congress 19–22.06.2018, Astana, Kazachstan
- [20] Olszewski J., Czaja P., Bulenda P., Kamiński P. Pogłębianie oraz wydłużanie górniczych wyciągów szybowych – szybu Leon IV w kopalni KWK ROW - Ruch Rydułtowy (Deepening of the Leon IV shaft for the Rydułtowy department of the ROW colliery and elongation of its hoisting system), Przegląd Górniczy 2018, T. 74, nr 8, s. 7-16
- [21] Olszewski J., Bulenda P., Chomański B., Jara Ł., Kamiński P. Szyb Leon IV – pogłębianie i wydłużenie górniczych wyciągów szybowych (Leon IV shaft – shaft deepening and elongation of the hoisting system), Inżynieria Górnicza 2017, nr 1-2, s. 49-52
- [22] Mieszczak M., Wowra D., Badaj W., Greń I., Kamiński P.: Przystosowanie szybu 1-Bzie do prowadzenia jazdy ludzi (Adaptation of the 1-Bzie shaft for the function of manshaft), Mechanizacja, automatyzacja i robotyzacja w górnictwie 2020, monografia, [red. K. Krauze], Wydawnictwo AGH, Kraków 2020
- [23] Kamiński P. i in. Szyb 1-bzie (Jan Paweł) – wykorzystanie kubłowego górniczego wyciągu szybowego do prowadzenia jazdy ludzi (1-Bzie shaft (Jan Paweł shaft) – utilisation of kibble hoisting system for purpose of hoisting of the staff), Inżynieria Górnicza 1/2020 s. 10-18
- [24] Nowak J., Wowra D., Motyka M.: Naczynie specjalnego przeznaczenia (Special-purpose conveyance). prezentacja na International Mining Forum 2017, 28-30.06.2017, KWK Szczygłowice
- [25] Małkowski P., Kamiński P. Mobile working platform unit, Polish patent PL236729B1, 08.02.2021
- [26] Fac Frank Abels Consult & Tech: Working platform, especially for working platforms or scaffolding, German patent DE29908954U1, 21.05.1999
- [27] Braud M.C.: Working platform in height, French patent FR2830557B1, 10.10.2001
- [28] Rijnders L.: Extendable working platform, particularly for a personnel lift, International patent WO2006052131A1, 15.11.2004