

Information Technology of Optimized Agro-biological State Management of Agricultural Lands

¹ V. Snytyuk, ²O. Brovarets

¹*Department of Intellectual and Information Systems
Taras Shevchenko Kyiv National University*

²*Department of Informational, Technical and Natural Sciences
Kyiv Cooperative Institute of Business and Law*

Received: May 11, 2019, accepted June 20, 2019

Abstract. Available techniques for dealing with uncertainties in the agro-industrial complex and their use for describing and assessing the adequacy of the decisions taken are incomplete, and often ineffective, as they usually do not take into account the combination of "field-machine-technological material", which prevents acceptance effective solutions for managing agro-biological potential of agricultural land and, as a consequence, obtaining the maximum economic efficiency of agricultural production. Reliable estimation of variables of agricultural production parameters using the "field-machine-technological material" model makes it possible to provide optimal control of available technical equipment (machinery, sowing machines, etc.), agro-biological (humus content, presence of nutrients, micro-and macro elements, etc. in soil or plant) and technological resources for making adequate decisions and managing agro-biological potential of agricultural lands, which will provide the necessary economic efficiency.

The task is achieved by ensuring the proper quality of the implementation of technological operations that are an integral indicator of economic efficiency and allow providing the necessary economic efficiency through optimal and efficient management of technical means for optimal action on the agro-biological potential of the field and the use of available technological resources. Such control is possible with the use of information and technical systems of local operational monitoring, which are located on machine-tractor units and provide effective control of technological operations by acting on the executive bodies of agricultural machines on the basis of data characterizing the agro-biological state of the soil environment.

Information and technical systems of local operational monitoring of the agro-biological state of agricultural lands are used in the following cases:

- before performing a technological operation,
- simultaneously with the implementation of the technological operation (sowing, fertilizer application, etc.),
- during the growing season and after harvesting.

This opens new prospects for organic farming using such "smart" agricultural machines.

Keywords: soil, samples, size, variability, uncertainty, adequacy, operational monitoring, information and technical system.

FORMULATION OF THE PROBLEM

Existing methods of controlling the agro-biological state of the soil environment do not take into account the variability of the values of their parameters over the area of agricultural land [1-25, 30]. In order to realize the technology of differentiated introduction of technological material, a simplified method of uniform division the field surface at the equal squares (preferably in the area of 5-15 ha) is used, for further diagnostics and control of the agro-biological state of the field using such differentiation. On the one hand, such a division is due to the convenience and simplicity of the method, on the other - there is a lack of reliable field data and, accordingly, a tool for splitting the field according to other criteria based on the source data. According to this method, to a conditionally equal square in the field may fall areas with fundamentally different parameters, the average value of which does not reflect the real values of parameters of this plot. The method of uniform division at the equal squares of the surface of the field does not take into account the specifics of the field and the heterogeneity zones, as a result of which there is a low reliability of the data obtained using such a method, and, accordingly, the possibility of using such data for the qualitative management of technological processes using the technology of differentiated introduction of technological material on the basis of operational data on the agro-biological condition of agricultural lands.

In some cases, the values of the soil environment parameters will be understated, and some will be overestimated within one square. Differentiated control of the norm of introducing technological material within the given square is carried out precisely on the basis of the average value of this parameter. Therefore, such a way to implement a differentiated introduction of technological material will be ineffective.

Under these conditions, there is a need to find a more effective way for operational monitoring of the agro-biological state of agricultural land.

The development and use of a fundamentally new

class of agricultural machinery - information and technical systems for operational monitoring of agricultural lands becomes of relevance.

A new class of machinery for agricultural production is used to obtain quick and reliable data on the agro-biological state of the soil environment - information and technical systems of local operational monitoring of agro-biological state of agricultural lands, in particular, by measuring the conductive properties of the soil environment. The conductive properties of the soil environment is a complex indicator of its agro-biological state, which takes into account the hardness, humidity, nutrient content in the soil, the saturation of the bases, the capacity of the cation exchange, and others like that.

High moisture content, salts and nutrients in the soil contribute to increasing the electrical conductivity of the soil environment within one field, recorded by the information technology system. Such information makes it possible to isolate the zones of variability of the soil environment and, in the future, to manage the agro-biological state of agricultural lands, taking into account heterogeneity zones.

ANALYSIS OF RECENT RESEARCHES AND PUBLICATIONS

The structure of the soil varies greatly in many agricultural fields. Physical properties of the soil, such as the soil structure, have a direct effect on water capacity, cation exchange capacity, yield, etc. Nutrients contained in soils are used by the plant, and their content in the soil decreases. The generally accepted characterization of nutrient content in soils is the content of nitrogen, the presence of which in soil largely determines the yield. Cartography of soil electrical conductivity is widely used as an effective means of mapping the soil structure and other soil properties [5].

A quick description of the variability of agricultural land is an important component for zonal control methods [6-16].

At present, the task of developing modern technologies of crop production, which helps to increase the competitiveness of agro-industrial production becomes a special urgency, it will ensure the food security of the country, its integration into world agricultural production, creation of scientific and technical division for a wide range of innovations in various sectors of agriculture.

Integrated systems of automatic control of the execution of technological processes [1-10] are the most promising and should ensure the creation of technologies with qualitatively new economic, social and environmental indicators. A great importance takes the level of integration with the information and technical systems used in agricultural production, which makes it possible to significantly improve the quality of the solution to the problem of managing the technological processes of agro-industrial production, where intensive development of advanced technologies is expected.

In order to solve the problem of ensuring the proper quality of the implementation of technological operations in crop production, a prognostic-compensating technology of changing standards for the introduction of technological material, based on monitoring data on the condition of agricultural lands, is called.

Modern methods and means of soil properties registration. It is obvious that for the proper organization of environmental quality management, the organization of an effective monitoring system is absolutely essential. In order to assess the state of the environment it is important to obtain objective operational information about the critical factors of anthropogenic action, the actual and future state of the biosphere. There is a problem of the organization of special systems of observation, control and assessment of the state of the environment (monitoring) both in places of intensive anthropogenic impact, and globally [3]. An important place at the present stage is registration of conductive soil characteristics.

Electrical conductivity is the property of the material to transmit (conduct) electric current, measured in Siemens per meter (S / m) or milliSiemens per meter (mS / m). The conductivity of the soil can also be expressed in decySiemens (dS / m). MilliSiemens per meter (mS / m) is a standard unit for measuring the electrical conductivity of the soil. By Siemens we measure electrical conductivity of materials. The advantage of a standard unit of measurement is that it gives accurate quantitative data. The visual assessment of the soil makes it easy to detect color differences, but does not give quantitative meaning and explanation of the essence of the color differences. Electrical conductivity maps of the soil indicate the value in mS / m, which allows you to learn and treat areas of similar electrical conductivity in the same way. As numerous laboratory-field studies have shown, there is a correlation between the parameters of electrical conductivity and the content of nutrients in the soil at certain values of its moisture and hardness due to granulometric composition of soil.

Electromagnetic characteristics of the soil combine many of the properties of the soil, which affect the yield of crops. These include soil moisture, granulometric composition of soil, cation exchange capacity (CEC), salinity, the content of exchange cations of calcium (Ca) and magnesium (Mg), etc. The electromagnetic characteristics of the soil do not allow the direct measurement of the nutrient content, but show the variability of important characteristics such as soil structure and the content of exchange cations. This variation is too important to ignore it and should be taken into account during sampling (Fig. 1) [17].

Soil conductivity maps provide an opportunity to get cartograms:

- variable norms of the introduction of technological material (seeds and mineral fertilizers) based on the expected yield of each individual plot, calculated on the basis of the electrical conductivity;
- variable norms of the seed rate based on the depth of

the upper (arable) layer of soil;

- variable norms of application of herbicide into the soil based on data on organic matter, soil structure and electrical conductivity;
- variable norms of the introduction of lime based on data on the agro-biological state of the soil environment in accordance with the levels of electrical conductivity.

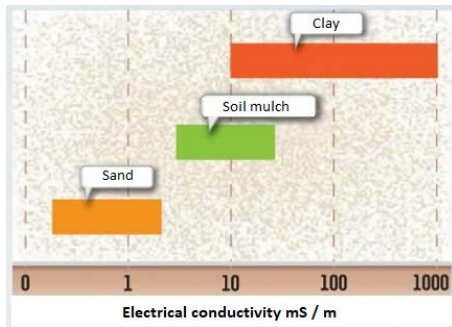

Fig. 1. Electrical conductivity of soil [17]

The most common instrument for monitoring the agro-biological state of the soil environment, by measuring the conductivity characteristics of the soil environment, is mapping the soil with the EC Veris 3100 device. It is connected to an off-road vehicle equipped with an on-board computer with parallel driving technology, a GPS receiver (Fig. 2) and a trailer unit with discs (located in disks electrodes). When carrying out measurements, the unit moves in the field with submerged discs to a depth of 2-5 cm, one pair of isolated electrodes enters the electric current into the ground; other electrodes measure the current, which varies depending on the resistance of the soil [4].

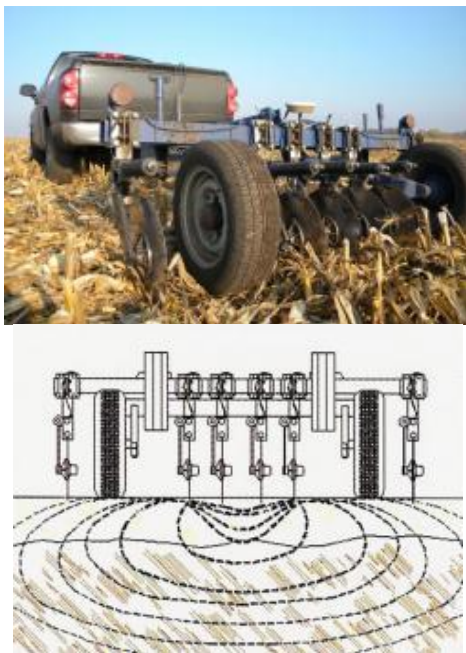

Fig. 2. EC Veris 3100 device

The Veris trailer unit moves along the field, one pair of isolated electrodes enters the electric current into the ground, and the other pair measures the voltage drop, which will be different - for example, the clay conducts current better than silt or sand. Measurements of electrical conductivity are combined with GPS data and are clearly displayed as a map. The Veris 3100 uses two electrical conductivity rays to map two depths of soil (0-30.5 cm and 0-91.5 cm) at the same time.

Veris 3100 forms two sets of maps - a map of the surface layer (30.5 cm) and a map of going deep to the root zone (91.5 cm). The top layer map is often used to select sampling points, and a deeper map to determine the fertilizer application rate (especially nitrogen) [5].

The purpose of this study is to increase the efficiency of agricultural production and decisions made by mathematical modeling of the functional structure of the implementation of technological operations in crop production.

MATERIALS AND METHODS

The scientific concept of the prognostic - compensating technology of changing norms for the introduction of technological material is based on obtaining information about the condition of agricultural lands (soil and vegetation state), on the basis of which, using specially developed mathematical algorithms, data processing is carried out for decision making on the implementation of the technology of nature management in the production of agricultural products. The prognostic-compensating technology of changing standards for the introduction of technological material includes the following main areas of activity: monitoring of factors affecting the state of the soil environment; assessment of the actual and forecast of the future state of the soil environment.

Thus, the necessary efficiency of production of crops and basic technological processes in crop production (Fig. 3) is ensured at the expense of the integrated information and technical provision of the system and monitoring of the state of agricultural lands, which makes it possible to ensure the proper quality of the implementation of technological operations in crop production through the operational management of technological processes in crop production.

For realization of this technology a model of the implementation of prognostic-compensating technology of changing norms for the introduction of technological material (Figure 4) has been developed. This technology, taking into account the specific nature of the soil environment, allows you to select a strategy for managing the agro-biological state of agricultural lands, aimed at: production of organic crop production, reduction of specific energy costs, obtaining maximum profit, obtaining maximum yields, etc. (Figure 4).

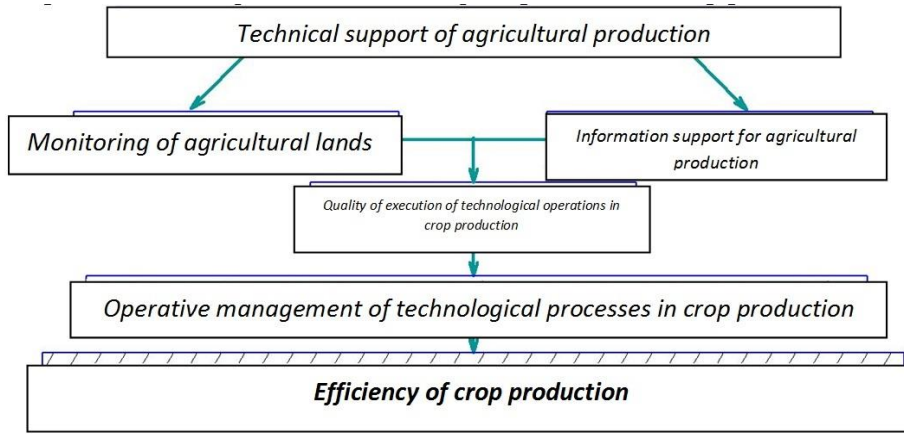

Fig. 3. The process of ensuring the proper quality of the implementation of the technological operation

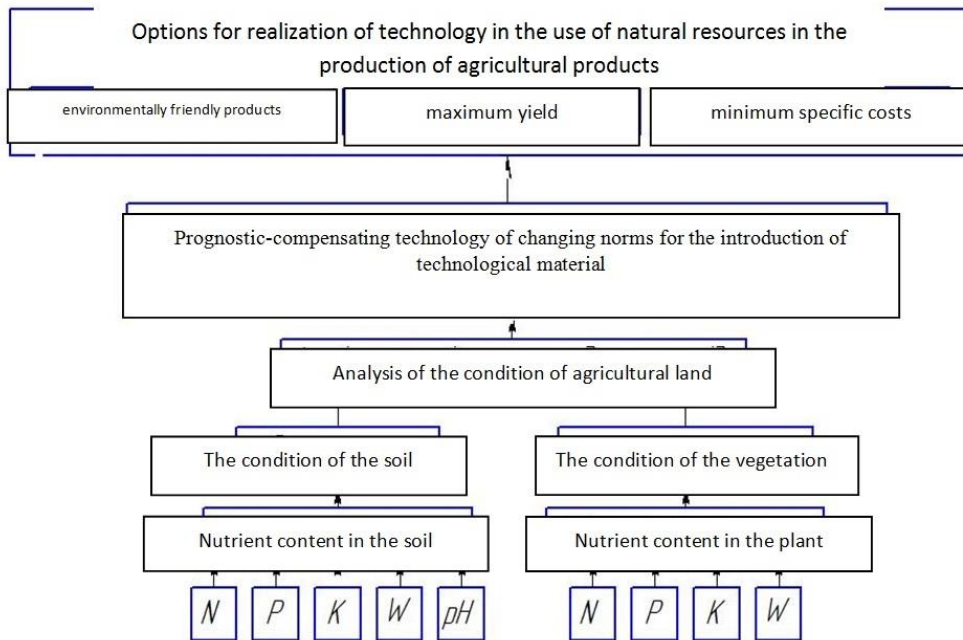

Fig. 4. Model of realization of prognostic - compensating technology of variable norms of introduction of technological material with the use of information and technical support for monitoring the state of agricultural lands

Information and technical systems of the local operational monitoring of the condition of agricultural lands provide an opportunity to achieve the appropriate quality control of the implementation of technological operations using modern information and technical mechatronic and robotic control systems associated with sensors for quality control of technological operations, which in the current context of their development have been called Smart Machines or Smart Machinery [1-15].

Such "smart" machines with operational monitoring sensors will be useful at all stages of agricultural production: basic cultivation, sowing (planting), growing crops during the growing season and harvesting. This allows to ensure the proper quality of the implementation of technological operations while optimizing the costs of their production. "Smart" machines "adapt" to the agro-biological state of the soil environment based on information from sensors on the agro-biological state of the soil environment [13-15].

It is worth noting that the importance and feasibility of using a technical system depends on the type of technological operation, the area of cultivation. So

expediency of using these machine-tractor aggregates is especially high at the stage of sowing (planting), since this technological operation is actually the "foundation" of the future harvest. However, when applying these aggregates, there is a need to develop a mathematical model of their ultimate speed of action, which takes into account the position of the sensors, the distance from their placement to the executive operating bodies, servo drives. Such a model will enable, based on the data on the type of sensors, the principle of their work, to form requirements for executive operations bodies (servo drives) to manage the quality of the implementation of a technological operation, which will allow implementation of the specified algorithm.

Modern technology of differentiated introduction of technological material with the use of technical systems for operational monitoring of agricultural lands gives an opportunity to provide "communication" of machines with agro-biological fields. Differentiated introduction of technological material (seeds, fertilizers, etc.) is important in terms of ensuring the maximum yield of crops.

The signal from the working bodies of the information and technical system of the local operational monitoring of the state of agricultural lands $F_{TSM}(t)$ becomes an analog-digital signal of the control unit of the technical system of operational monitoring of the state of agricultural lands $U^{ADA}(t)$. Then, after amplification, this signal $U_{USB/RS232}(t)$ is transmitted to the main module of the technical system of operational monitoring of the state of agricultural land. For the visualization of the results of the technological operations, the display of the information and technical system of the local operational monitoring of the state of agricultural lands $U_{RS232}(t)$ is used.

The main module of the technical system of operational monitoring of the condition of agricultural lands sends a signal $U_{V_RS232}(t)$ to the driver of the management of the information and technical system of the local operational monitoring of the state of agricultural lands. From the control driver there is a signal $U_{RS232}^{EM}(t)$ to the executive mechanism of the operational system of the technical monitoring system, which through mechanical communication $F_{AM}^{EB}(t)$ provides an effect on the working body of the agricultural machine that performs the technological operation.

$$U_{\alpha}^{\beta}(t) = U(t_{\beta} - t_{\alpha}) = \int_{t_{\alpha}}^{t_{\beta}} \left[F_{TSM}(t) + U^{ADA}(t) + U_{USB/RS232}^{ADA-MM}(t) + U^{ED-MM}(t) + U_{RS232}^{MM-CD}(t) + U_{RS232}^{MM-MD}(t) + U^{MD-EM}(t) + U^{EM}(t) + F_{AM}^{EB}(t) + F_{AM}^Q(t) + F_S^Q(t) + U^{FB}(t) \right] dt \leq \mu(t_{\alpha}). \quad (1)$$

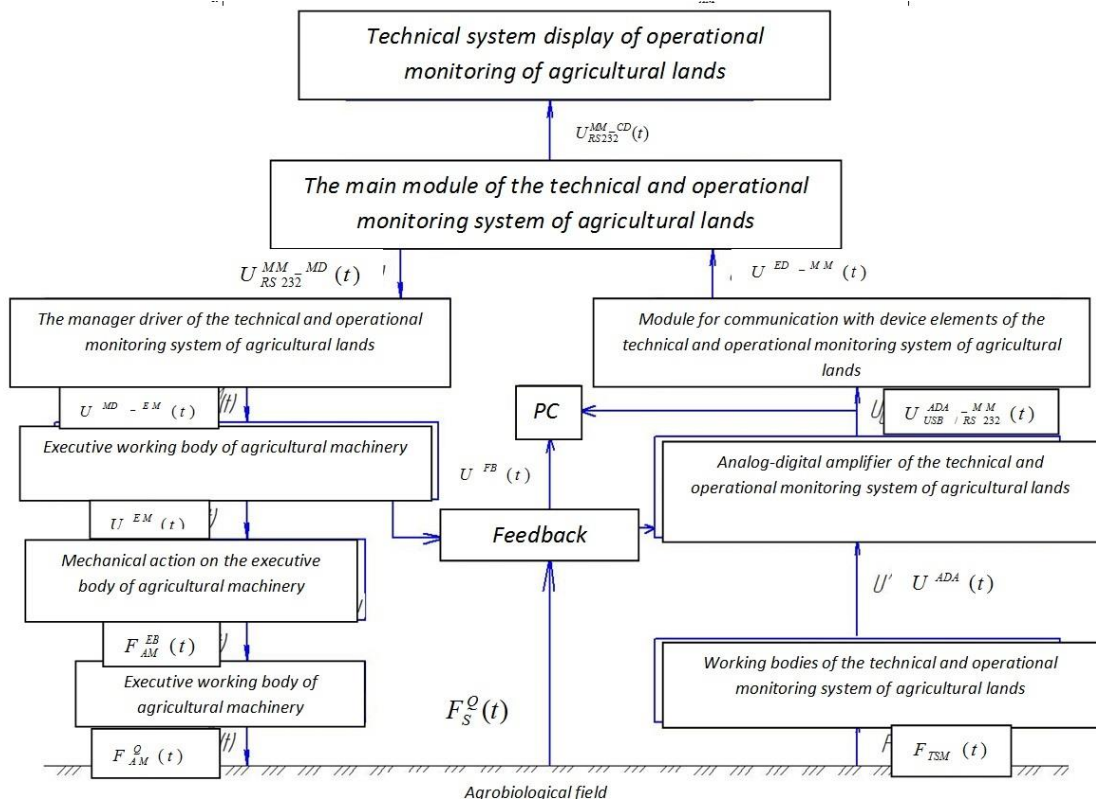

Fig. 5. Block diagram of the implementation of the optimal quality control of a technological operation based on the information and technical system of local operational monitoring data of the state of agricultural lands

The function of optimal control is as follows:

$$U_{OC}(t) = F_{TSM}(t) + U^{ADA}(t) + U_{USB/RS232}^{ADA-MM}(t) + U^{ED-MM}(t) + U_{RS232}^{MM-CD}(t) + U_{RS232}^{MM-MD}(t) + U^{MD-EM}(t) + U^{EM}(t) + F_{AM}^{EB}(t) + F_{AM}^Q(t) + F_S^Q(t) + U^{FB}(t). \quad (2)$$

Where:

$F_{TSM}(t)$ is a function that describes the functioning of the information and technical system of the local

operational monitoring of the condition of agricultural lands in the course of a technological operation;

$U^{ADA}(t)$ is a function that describes the output signal obtained from the working electrodes of the information and technical system of the local operational monitoring of the state of agricultural lands to the analog-digital converter of the amplifier using shielded wires;

$U_{USB/RS232}^{ADA-MM}(t)$ is a function that describes the output signal obtained from the analog-to-digital

converter of the technical system of operational monitoring of the state of agricultural lands and sends a signal to the communication module from the information and technical system of the local operational monitoring of the state of agricultural lands using a port *RS 232* or a personal computer with the help of the port *USB*;

$U^{ED-MM}(t)$ is a function that describes the connection of the elements of the device with the main module of the technical system of operational monitoring of the state of agricultural lands;

$U_{RS232}^{MM-CD}(t)$ is a function that describes the signal received from the main module to the control display of the information and technical system of local operational monitoring of the state of agricultural lands;

$U_{RS232}^{MM-MD}(t)$ is a function that describes the signal received from the main module to the manager driver of the information and technical system of the local operational monitoring of the state of agricultural lands;

$U^{MD-EM}(t)$ is a function that describes the output signal received from the manager driver to the executive bodies of the information and technical system of the local operational monitoring of the state of agricultural lands;

$U^{EM}(t)$ is function of changing the voltage of control of the executive mechanism of the technical system of operational monitoring (in this case, the electric motor or servo drive);

$F_{AM}^{EB}(t)$ is a function that describes the management of the executive bodies of agricultural machinery performing a technological operation (chain transmissions, variator and other mechanical parts);

$F_{AM}^O(t)$ is a function that describes the mechanical action of executive bodies of an agricultural machine on the quality of the technological process;

$F_S^O(t)$ is a function that describes information from a quality performance sensor for a technological operation placed on an agricultural machine with operational quality control, depending on the technical systems of operational monitoring;

$U^{FB}(t)$ is a function that describes the feedback from the parameters and operating modes of executive machinery of agricultural machines and is synchronized with the data of an analog-digital amplifier of the technical system of operational monitoring of the state of agricultural lands $U_{USB/RS232}^{ADA-MM}(t)$ and transmitted to the main module;

PC is a personal computer that receives information from a function $U_{USB/RS232}^{ADA-MM}(t)$ that describes the output signal received from the analog-digital amplifier of the technical system converter of the operational monitoring of the state of agricultural land using the *USB*-port.

The device for determining the conductive properties of the soil environment is used: before the execution of the technological operation, simultaneously with the implementation of the technological operation (sowing, application of mineral fertilizers, etc.); during the growing season and after harvesting. This opens new prospects for organic farming using such "smart" agricultural machines.

Figs. 6, 7 - show the general view of the information and technical system of local operational monitoring of agricultural lands (top view) [29], in Fig. 8 - general view of the information and technical system of local operational monitoring of the state of agricultural lands (side view).

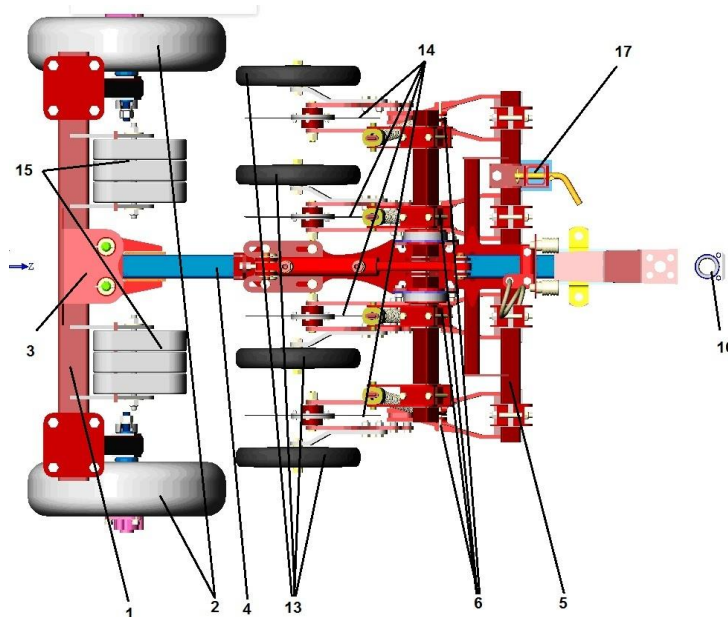

Fig. 6. General view of the technical system of operational monitoring of the state of the soil environment (top view)

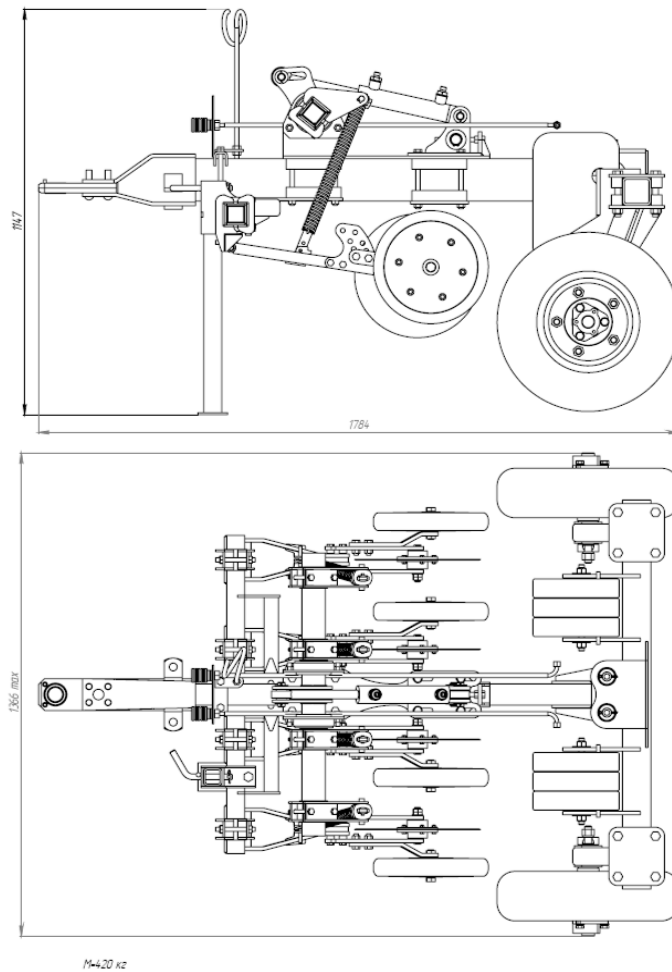

Fig. 7. Scheme of the technical system of operational monitoring of the soil environment

Such a technological solution will enable to provide optimum control of the norm of seeding of technological material (seeds, fertilizers, etc.), taking into account the agro-biological state of the soil environment.

The information and technical system of operational monitoring of the soil environment (fig.8.) consists of the support wheels 1, II-shaped frame 2, fastening 3, longitudinal frame 4, transverse frame 5, hinges 6, levers 7, vertical springs 8, bracket 9, a rotary shaft 10, a hydraulic cylinder 11, a mount bracket 12, gage wheels 13, working electrodes 14, a ballast 15, a tow 16 and a stand 17.

The information and technical system of local operational monitoring of the condition of agricultural lands works as follows: the movement of the information and technical system of local operational monitoring of agricultural lands is carried out using a vehicle with the support wheels 1, on which the II-shaped frame 2 is placed, to which, with the help of a fastening 3 the longitudinal frame 4 is attached. To the longitudinal frame 4, a transverse frame 5 is attached, to which, through the hinges 6, the levers 7 and the vertical springs 8, the gage wheels 13 are attached with working electrodes 14. Adjustment of the depth of the working electrodes 14 occurs with the help of gage wheels 13, and with the help of vertical springs 8, which are fixed to the rotary shaft 10, the hydraulic cylinder 11 and the mount

bracket 12, the working electrodes are pressed to the surface of the field and copying their inequalities. The implementation of the lifting / lowering mechanism of the working electrodes 14 occurs using a bracket 9 to which a hydraulic cylinder 11 is attached, which rotates the shaft 10 through the mounting bracket 12 (Fig. 9).

In both the theory and the practice of data analysis, in the vast majority of cases structural and parametric dependency identification is necessary:

$$Y = F_1(X_1, X_2, \dots, X_n) \quad (3)$$

where Y is the endogenous variable, X_n is exogenous factors or indicators influencing Y , $i = \overline{1, n}$. In order to perform structural and parametric identification (3) (to execute a model specification) - means to set the form of dependence (or to determine the class of dependencies to which the unknown will belong). Parametric identification is the calculation of the values of the dependency parameters (3). Of course, structural identification is preceded by a parametric one. As a rule, structural identification can be carried out repeatedly and the number of attempts depends on the experience of the analyst or on the power of a set of models given algorithmically. Parametric identification is realized by using a specific method tightly tied to a definite pattern of the model.

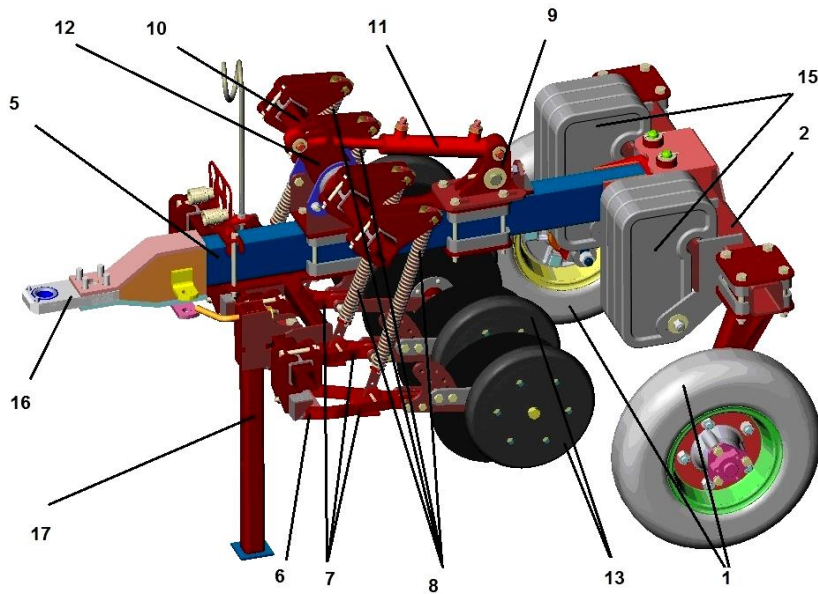

Fig. 8. General view of the technical system of operational monitoring of the state of the soil environment (side view)



Fig. 9. Functioning of the device for determining the conductive properties of the soil environment on different types of agricultural background

The source data for constructing the model (3) are data tables of the object-property type, where the rows correspond to objects, observations or experiments, and the columns are exogenous factors. The data table may contain a small number of entries $k \leq n$ or the number of entries is quite significant, $k \geq n$. Both, in the first and in the second case, it is necessary to perform

additional actions on the data so that they can be used to construct an adequate model (1). Consider the first case. If there is an assumption that the model (3) is a linear multifactorial regression, then the power of the output data must be increased to a minimum $n + 1$. As a rule, this is done by applying elementary arithmetic operations to existing lines. If such a model has a direct-connected neural network, then on such a set of data it can be taught, but the accuracy of learning leaves much to be desired because of the scarcity of filling the learning space and, as a result, the small predictability of the prediction of the resulting characteristic. You can increase accuracy by applying arithmetic operations as described above. In addition to these two approaches, it is rational to apply the group method of data handling (GMDH) [1]. The method works on samples of low power, its disadvantage is the need to implement a relatively complex algorithm for converting functional dependences to a "canonical" type (with minimal functional attachments and reduced coefficients).

What problems accompany the processing of powerful data samples? First, if the initial data is measured or obtained with errors and this fact takes place for many X_i , the values of the characteristics Y will be shifted, which will not allow for an acceptable, accurate parametric identification of the characteristic Y . On the other hand, since for the construction of the model as a multiple linear regression the determinant of the matrix of exogenous factors is used, then there is a high probability that at least two linear lines or rows with significant values of the correlation coefficient ≈ 1 are present in the tables. Then, to calculate the value of the regression parameters, you need to divide by a number ≈ 0 , which leads to overflow of the bit computer grid. If the model is a neural network, then a large amount of data can lead to over-training and biased prediction. The GMDH method at application shows the same problems as the linear

multiple regression, since they should be based on the least squares method (LSM).

How to improve the accuracy of the identification? First, you need to remove lines - "emissions". To determine such lines it is enough to find an average value

$$\bar{x} = \left(\frac{1}{k} \sum_{i=1}^k x_{i1}, \frac{1}{k} \sum_{i=1}^k x_{i2}, \dots, \frac{1}{k} \sum_{i=1}^k x_{in} \right). \text{ If } d = d(\bar{x}, x^j) > D,$$

where d is the distance between the rows, x^j is the j -th row, D is fixed, predetermined by the researcher value, then x^j is row is an "emission". The traditional way to handle the "emission" is to extract it from the data table. As a rule, this method is effective for a large amount of data. If the power of a plurality of data is small and the logic of the process of obtaining an "emission" indicates the peculiarities of a particular process, then such an "emission" should be left, somehow assimilating it.

Second, exogenous factors may be dependent, although the very name "exogenous" itself already implies independence. Dependent factors make it impossible to construct a model in the form of linear multiple regression, since it distorts its adequate interpretation. In order to get rid of this phenomenon, they conduct multicollinearity testing on a variety of factors, then conduct multicollinearity testing of each factor with a set of others and at the end of the test subject to each pair of factors. If two factors correlate with each other, then one of them is removed. One that correlates with other factors more. If necessary, the procedure is repeated. This procedure is significant when using GMDH and does not play a special role in the training of neural networks.

Third, there may be gaps in the data table caused by various reasons. At the discretion of the researcher, the corresponding lines can be deleted if they do not constitute a "critical mass" for constructing the models and their extraction will not lead to the loss of valuable information. Known ways to recover the gaps are filling in the average value in the column, constructing the regression and filling the calculated values in a line, applying methods using the complete matrix, regression equation and correlation coefficient. One of the author's works [27] proposes the combined use of artificial neural networks and evolutionary optimization methods, and for the restoration of missed values both among endogenous characteristics and among endogenous factors. Unlike others, the accuracy of the recovery remains acceptable even with 20% of data gaps.

Let us consider the problem of maximizing the average expected yield of agricultural crops by adjusting agro-biological parameters using the information and technical system of local operational monitoring of the agro-biological state of agricultural lands. The efficiency of solving this task depends on three components: agro-biological parameters, agricultural machines and technological material (Fig. 10).

It is obvious that the first component, which is the determining factor for the yield of agricultural crops, is the agro-biological parameters of the field. To a large extent, such parameters are subject to correction and our

task is to determine the extent to which each parameter is affected by increasing or decreasing its value. Without limitation of generality, we consider that the conductivity of the soil can be measured at any point of the field with the required discreteness. It is known that agro-biological parameters include the following parameters, which are conventionally divided by significance into three levels:

Level 1 (general soil indicators):

W (humidity), pH (acidity), Org (content of organic matter), Em (electrical conductivity).

Level 2 (macro elements):

N (nitrogen), P (phosphorus), K (potassium).

Level 3 (micro elements):

Ca (calcium), Mg (magnesium), S (sulfur), Cu (copper), Zn (zinc), Mn (manganese), Co (cobalt), Br (bromine), Md (molybdenum).

All of these elements influence the yield of crops in one way or another. By degree of influence, they are conditionally divided into three levels:

Level 1: W (humidity), pH (acidity), Org (content of organic matter), Em (electrical conductivity).

Level 2: N (nitrogen), P (phosphorus), K (potassium).

Level 3: Ca (calcium), Mg (magnesium), S (sulfur), Cu (copper), Zn (zinc), Mn (manganese), Co (cobalt), Br (bromine), Md (molybdenum).

In order to be able to write production rules to determine the optimal (acceptable) values W , pH , Org , Em , N , P , K , Ca , Mg , S , Cu , Zn , Mn , Co , Br , Md you must get a dependence:

$$Em = F(W, pH, Org, N, P, K, Ca, Mg, S, Cu, Zn, Co, Br, Md), \quad (4)$$

where Em is an electrical conductivity of the soil environment, where the cultivation of crops takes place, W , pH , Org , N , P , K , Ca , Mg , S , Cu , Zn , Co , Br , Md are the concentrations of elements in a square meter of soil.

The initial data is a table (Table 1) with measurement data at different points in the field or in fields with similar agro-biological indicators.

Work with the data of the Table 1 is carried out in accordance with the procedures outlined above. But in order to estimate the changes in the value of the agro-biological parameters of the soil environment, it is necessary to solve: according to the electrical conductivity, set the value W , pH , Org , N , P , K , Ca , Mg , S , Cu , Zn , Co , Br , Md it means to find:

$$\begin{aligned} K &= f(Em) \\ W &= a(Em), pH = b(Em), Org = c(Em), \\ N &= d(Em), P = e(Em), K = f(Em), \\ Ca &= g(Em), Mg = h(Em), S = i(Em), \\ Cu &= j(Em), Zn = k(Em), Co = l(Em), \\ Br &= m(Em), Md = n(Em) \end{aligned} \quad (5)$$

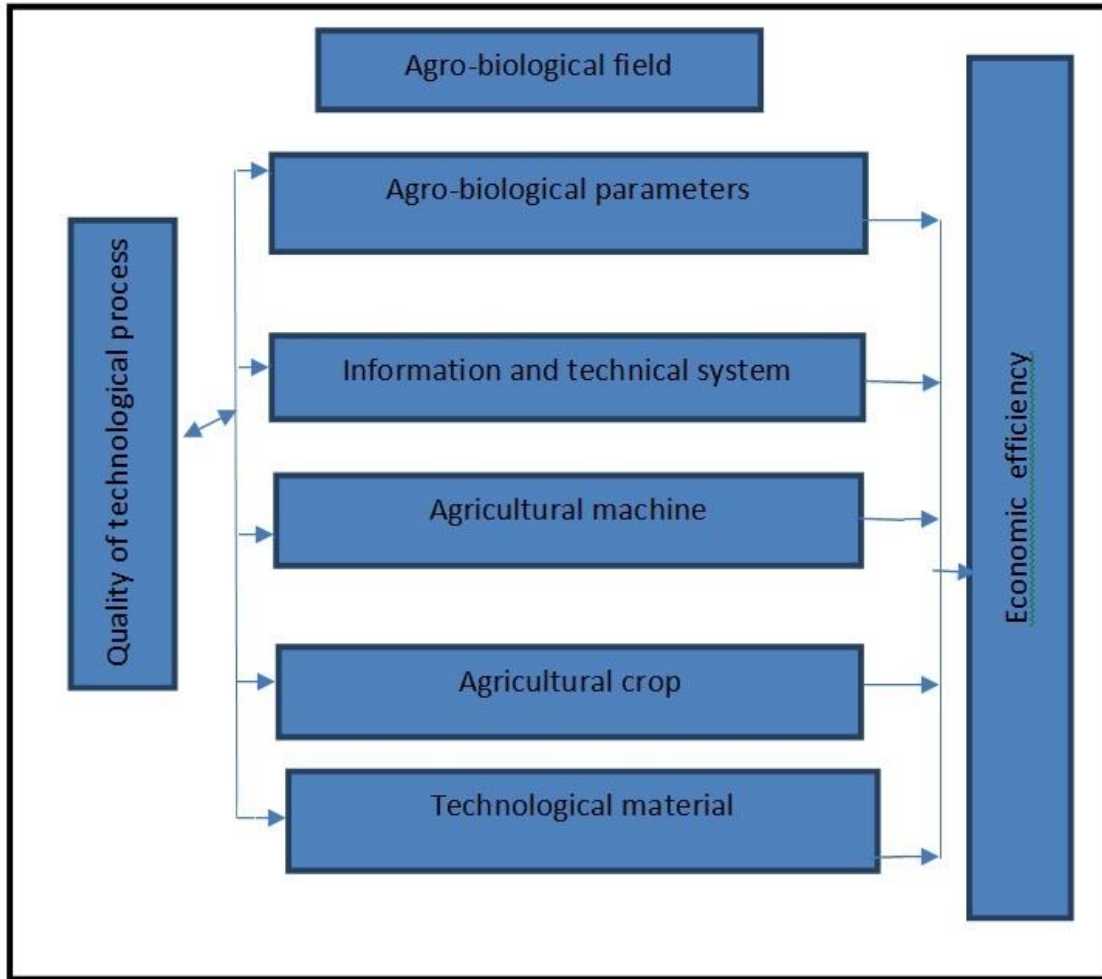

Fig.10. Components of task solving this efficiency

where $a(Em)$, $b(Em)$, $c(Em)$, $e(Em)$, $f(Em)$, $g(Em)$, $h(Em)$, $i(Em)$, $j(Em)$, $k(Em)$, $l(Em)$, $m(Em)$, $n(Em)$ are some functions that describe the dependence of parameters on the value of electrical conductivity. In the general case, it is impossible to do this, since solutions exist for an infinite number, and the solution found will not necessarily be final. Therefore, we propose to use a neural network of counter propagation [28]. Its feature is that the input and output after training must coincide, that is, we have that $Z = V(Z)$ or $(X, Y) = V(X, Y)$, or in our case

$$(W, pH, Org, N, P, K, Ca, Mg, S, Cu, Zn, Co, Br, Md, Em) = V(W, pH, Org, N, P, K, Ca, Mg, S, Cu, Zn, Co, Br, Md, Em) \quad (6)$$

After training the network and submitting to its input only one value Ep_j of four ($W_j, pH_j, Org_j, N_j, P_j, K_j, Ca_j, Mg_j, S_j, Cu_j, Zn_j, Co_j, Br_j, Md_j$) at the output we will get all fourteen values, where the first three will be the very sought. It is such a combination that will correspond to the value Ep_j . In order not to get values beyond the limits of consideration, it is advisable to analyze the results prior to their use, or to provide one or more

parameters on the network input / output that will reflect the balance criterion between the a priori four values of agro-biological parameters. Such a method will allow us to find the values of concentration $W, pH, Org, N, P, K, Ca, Mg, S, Cu, Zn, Co, Br, Md$, due to the values of electrical conductivity Em .

Finding the appropriate values $W, pH, Org, N, P, K, Ca, Mg, S, Cu, Zn, Co, Br, Md$ is not an end in itself. We also need to determine at what values of these parameters the yield U will be maximum, with minimum values of economic efficiency. This requires a table (Table 2) with retrospective data. Having identified the dependency:

$$U = W(W, pH, Org, N, P, K, Ca, Mg, S, Cu, Zn, Co, Br, Md), \quad (7)$$

here U is a yield, we need to solve the occurrence problem.

$$\begin{aligned} & \arg \max \perp (W, pH, Org, N, P, K, Ca, Mg, \\ & S, Cu, Zn, Co, Br, Md)U = \\ & = \arg \max \perp (W, pH, Org, N, P, K, Ca, Mg, \\ & S, Cu, Zn, Co, Br, Md) \\ & \left[\begin{array}{l} W(W, pH, Org, N, P, K, Ca, Mg, \\ S, Cu, Zn, Co, Br, Md) \end{array} \right] \end{aligned} \quad (8)$$

Its solution is $K_{max}, W_{max}, pH_{max}, Org_{max}, N_{max}, P_{max}, K_{max}, Ca_{max}, Mg_{max}, S_{max}, Cu_{max}, Zn_{max}, Co_{max}, Br_{max}, Md_{max}$

and values $W_t, pH_t, Org_t, N_t, P_t, K_t, Ca_t, Mg_t, S_t, Cu_t, Zn_t, Co_t, Br_t, Md_t$ in a certain part of field, will allow us to make a change in the concentration on the values in accordance with the species of plants $\delta_W, \delta_{pH}, \delta_{Org}, \delta_N, \delta_P, \delta_K, \delta_{Ca}, \delta_{Mg}, \delta_S, \delta_{Cu}, \delta_{Zn}, \delta_{Co}, \delta_{Br}, \delta_{Md}$, that is

$$\begin{aligned} \delta_k &= k_{max} + k_t, \delta_W = W_{max} + W_t, \\ \delta_{pH} &= pH_{max} + pH_t, \delta_{Org} = Org_{max} + Org_t, \\ \delta_N &= N_{max} + N_t, \delta_P = P_{max} + P_t, \\ \delta_K &= K_{max} + K_t, \delta_{Ca} = Ca_{max} + Ca_t, \\ \delta_k &= Mg_{max} + Mg_t, \delta_S = S_{max} + S_t, \\ \delta_{Cu} &= Cu_{max} + Cu_t, \delta_{Zn} = Zn_{max} + Zn_t, \\ \delta_{Co} &= Co_{max} + Co_t, \delta_{Br} = Br_{max} + Br_t, \\ \delta_{Md} &= Md_{max} + Md_t \end{aligned} \quad (9)$$

If values $W_t > W_{max}, pH_t > pH_{max}, Org_t > Org_{max}, N_t > N_{max}, P_t > P_{max}, K_t > K_{max}, Ca_t > Ca_{max}, Mg_t > Mg_{max}, S_t > S_{max}, Cu_t > Cu_{max}, Zn_t > Zn_{max}, Mn_t > Mn_{max}, Co_t > Co_{max}, Br_t > Br_{max}, Md_t > Md_{max}, K_t > K_{max}$ or $Ca_t > Ca_{max}$ or $Mg_t > Mg_{max}$, then the value of the concentration of the corresponding element is not necessary to be adjusted.

TABLE I. OUTPUT DATA FOR FINDING THE CONCENTRATIONS OF ELEMENTS

K	Ca		Ep
K_{11}	Ca_{11}	Mg_{11}	Ep_1
K_{21}	Ca_{21}	Mg_{21}	Ep_2
...
K_{n1}	Ca_{n1}	Mg_{n1}	Ep_n

TABLE 2. OUTPUT DATA FOR FINDING THE YIELD

K	Ca		U
K_{11}	Ca_{11}	Mg_{11}	U_1
K_{21}	Ca_{21}	Mg_{21}	U_2
...
K_{n1}	Ca_{n1}	Mg_{n1}	U_n

CONCLUSION

The result of using the proposed methodology to assess the adequacy of the decisions taken and their economic efficiency by mathematical modeling of the functional structure of the implementation of technological operations in crop production on the basis of agro-biological data of agricultural lands is the increase in profits by 20-30% due to optimization of the seeding standard of the technological material, taking into account the agro-biological state of agricultural lands.

RERERENCES

- Hertz A. Chad and John D. Hibbard. 1993. A Preliminary Assessment of the Economics of Variable Rate Technology for Applying Phosphorus and Potassium in Corn Production. In: Farm Economics iss. 14, Department of Agricultural Economics, University of Illinois, Champaign-Urbana. 218-231.
- Medvedev V.V. 2007. Soil heterogeneity and precision farming. Part I. Introduction to the problem. Kharkov. 296.
- Ivanov Yu.P, Sinyakov A.N., Filatov I.V. 1984. . Integration of information and measuring devices LA. 207 p.
- Druzhba-Nova. Available at <http://druzhba-nova.com/ru/index.html>.
- Kbo-agro. Available at <http://kbo-agro.com.ua>.
- Geonics Limited. Available at www.geonics.com.
- Veristech Available at <http://www.veristech.com>.
- Patent No. 66982 dated January 25, 2012, bullet. No. 2, IPC B62D 01/00.
- Vadyunina A.F. 1937. To the assessment of electrical conductivity as a method for determining soil moisture. Soil Science. No. 3. :391-404.
- Wilcox G.G. 1947. Determination of electrical conductivity of soil solutions. Soil Science. v. 63. 107 p.
- Ewart G.Y., Baver L.D. 1950. Salinity Effects on soil moisture electrical resistance relationships. Soil Scienc. Soc. Amer. v. 15: 56-63.
- Vorobev N.I. 1955. To the question of conductometric determination of soil and soil salinity. Soil Science. №4. - p. 103.
- Rhoades J.D. Schifgaarde J. Van. 1967. An electrical conductivity probe for determining soil salinity. Soil Scien. Soc. Amer. J. № 5: 647-651.
- Kopikova L.P. 1979. Experience in the use of electrical conductivity for the preparation of detailed soil and soil maps. Bulletin of the VIUA. No. 43: 21-23.
- GOST 26423-85. Soils. Methods for the determination of electrical conductivity, pH and dense residue of the aqueous extract. p.7.
- Pansu M. Gautheyrou J. 2006. Handbook of soil analysis. Mineralogical, organic and inorganic methods. Springer-Verlag Berlin Heidelberg. 993 p.
- Agrotechnology. Available at <http://agrotechnology.com/tochnoe-zemledelie/ideologi/o-chem-rasskazyvaet-udelnaya-elektroprovodnost-pochvy>.
- Gukov Ya.S. Linnik N.K., Mironenko V.G. 2001. Automated system of locally dosed application of fertilizers, ameliorants and plant protection products. In: Proceedings of the 2nd MNPK on the problems of differential application of fertilizers in the coordinate farming system. Ryazan: 48-50.

19. **Brovarets O. 2002.** From the Straightforward to the Global Smart Agriculture. Engineering and Technology of Agroindustrial Complex. No. 10 (85): 28-30.
20. **Adamchuk V.V., Moiseenko V.K., Kravchuk V.I., Voytyuk D.G. 2002.** Technique for future agriculture. In: Mechanization and electrification of agriculture. Glevakha: NSC "IMESG". Ed. 86: 20-32.
21. Modern trends in the development of agricultural machinery designs. Editors V.I. Kravchuk, M.I. Grytshyshina, S.M. Koval – Kyiv, Agrarian Science, 2004. 398 p.
22. **Ormadzhi K.S. 1991.** Quality control of field work. M.: Rosagropromizdat. 191.
23. **Pontryagin L.S., Boltyansky V.G., Gamkrelidze R.V., Mishchenko E.F. 1983.** Mathematical theory of optimal processes. M.: "Science. 392.
24. Burachek V.G. Zheleznyak O.O., Zatserkovny V.I. 2011. Geoinformation analysis of spatial data. Nizhyn: Aspect-Polygraph Publishing Ltd. 440.
25. **Maslo I.P.** Mironenko V.G. 1999. Automated system of locally-doped fertilizer and chemical plant protection products. UAAN: Development-production. Kyiv, Agrarian Science: 348-349.
26. **Ivakhnenko A.G., Yurachkovsky Yu.P. 1987.** Modeling of complex systems by experimental data. Moscow, Radio and communication. 120.
27. **Snytyuk V.Ye. 2005.** Evolutionary simulation of the process of recovery of missing values in data tables In: Proceedings VII intern. sci. pract. conf. "System Analysis and Information Technologies". Kyiv: NTUU of Ukraine "KPI", 157.
28. **Wasserman F. 1992** Neurocomputer engineering: theory and practice - Moscow, Mir. 240.
29. **Brovarets O. 2019.** Method of calculation of specific electrical conductivity of agro-biological soil environment by stationary contact method of operating electrodes of information and technical system of local operating monitoring. Econtechmod. Vol 8, no 1: 3-10.
30. **Brovarets O., Chovnyk Yu. 2017.** Technical – economic models of business management in the processes of agricultural production. Econtechmod. Vol 6, no 3: 61-70.