

A STUDY ON FIBRE-REINFORCED CONCRETE ELEMENTS PROPERTIES BASED ON THE CASE OF HABITAT MODULES IN THE UNDERWATER SILLS

Marzena Kurpińska

Beata Grzyl

Adam Kristowski

Gdańsk University of Technology, Poland

ABSTRACT

Hydrotechnical constructions are mostly objects functioning in extreme conditions and requiring a custom-made construction project. In the case of using prefabricated elements, it is required to develop production, transport, assembly, conservation and repair technology. Concerning the problem of concrete cracks, modern repair systems allow positive effects to be achieved in many cases of concrete elements repair. In this work an attempt has been made to assess the properties of concrete, situated in the Baltic Sea environment, in which traditional rebar was partly replaced by dispersed fibre-phase. Fibre-reinforced concrete belongs to the group of composite materials. The presence of fibres helps to increase the tensile strength, flexural strength and resilience and also prevents the appearance of cracks. In the given paper we will also discuss basic parameters of steel and polymer fibres and the influence of both types of fibres on the maturing and hardened concrete. In this work special attention has been paid to the advantages of polypropylene and polymer fibres with regard to commonly-known steel fibres. The use of synthetic fibres will be advantageous in constructions where the reduction of shrinkage cracks and high resilience are essential. On top of that, the use of synthetic fibres is highly recommended when constructing objects that will be exposed to the impact of an aggressive environment. Undoubtedly, polymer fibres are resistant to the majority of corrosive environments. Fibre-reinforced concretes are a frequently implemented construction solution. The possibility of concrete modification allows the emergence of new construction materials with improved physical-mechanical properties, under the condition of being applied relevantly.

Keywords: hydrotechnical constructions; fibre-concrete; mechanical concrete; strength; X-ray tomography

INTRODUCTION

The variety of the types and forms of Polish seashores requires the implementation of varied methods for their protection, beginning with artificial nourishment up to building hydrotechnical constructions of different kinds. The actions taken with the aim of shore protection to some extent alter the natural sea currents system, modifying the shore directly or indirectly and, in addition, bring alterations to the coastal zone's bottom morphology [1–2]. These alterations influence the configuration, character and continuity of habitats, and are a threat to the biocenosis inhabiting them [3]. This is a matter of major importance, especially in protected zones, in which

the main object of protection are habitats, i.e. in the habitat protection area Natura 2000. The methods used for protection of the Polish Baltic shores are the following:

- Artificial nourishment of the shore – supplementing losses of coast-building material by means of sand taken from other areas, and coast shaping with the purpose of breaking storm waves. This method is used either permanently or temporarily in the case of coastal erosion. The disadvantage of this method is the destruction of the bottom flora and fauna habitat in the areas of both nourishment supply sources and nourishment proper, and also at the boundary between the land and the sea, in the area of nourishment by means of sand.

- Seawalls – constructions situated parallel to the coastline, protecting the lower part of the dune slope, cliff or artificial dyke from erosion. They can also prevent landslides occurring on the steep slopes of dunes and cliffs. Seawall construction, however, often goes together with eluviation on either side of the wall, material eluviation from the outer part of the wall, or local bottom erosion at the wall as a result of strong outward currents in the waves [4], which negatively influences the condition of the bottom flora and fauna habitats.
- Groynes – hydrotechnical constructions, situated perpendicular to the coastline, accumulating and maintaining the width and the height of a beach at which slope waves of all sizes should be broken. These constructions are being used in areas with significant sediment movement along the shore.
- Underwater sills – hydrotechnical constructions situated on the bottom parallel to the shore and at a certain distance from it with the aim of wave energy dispersion by selective forcing of the breakage of the highest waves and creation of favourable conditions for sediment accumulation in the exposed area. This method helps to avoid undesirable underwater phenomena caused by breakwater structures. It also enables better water rotation in the exposed area (Figs. 1 a, b).



Fig. 1. Examples of the habitats for sea organisms in underwater sills

CASE STUDY

The aim of the following case study was the analysis of the selection of concrete components and the influence of those components on the durability of underwater concrete. It is common knowledge that the improvement of a concrete structure does not guarantee the durability of the complete construction. The factors which influence that durability are as follows: following construction procedures, following the rules of concrete production technology, correct transportation and underwater casting procedures. The consequences of construction failures and technological mistakes in the case of underwater concrete are particularly disastrous and their correction is either extremely expensive or simply impossible. Therefore, in the case of such constructions, special control rules and regulations must be implemented and they must embrace all the elements of the technological process. The objects of the analysis were prefabricated concrete elements – habitat modules meant

for the construction of an artificial reef. The elements were placed alongside the coastline at different depths. The water surface over the main element lid was 1.2–2.0 m.

PROJECT

The habitat module has to carry out two major functions: it has to constitute a reproduction habitat for plants and animals and to absorb wave energy, blocking bedload flowing from the beach. A habitat module in the shape of a reinforced concrete circular plate with a bottom inner diameter of 2 m was designed, with a slot of 1.0 m in the lid. Sea current from the waves flows through the side slots, and some of this current is directed upwards. The water flowing through the upper slot must cause a pressure difference between the top and the bottom of the element, which must lead to element stabilisation at the bottom. Some of the wave energy flows through the side slots, reducing the inner pressure and preventing the element from rotation. The porous surface of the element enables adhesion of benthos. It is assumed that the concrete pH will remain within the range of 8–8.5, for the modules to be inhabited by both animals and plants. In Baltic Sea water, the pH fluctuates between 7.77 and 8.61 and depends on the water temperature. The height of the habitat module depends on local underwater conditions. Several versions of modules were designed. The module inner diameter is 2 m, with outer height 1.5–2.5 m, outer diameter 2.3–2.44 m, wall thickness 0.15–0.23 m. The element volume constituted 1.8–2.5 m³ and the element mass 4.98–5.25 t (Fig. 2).

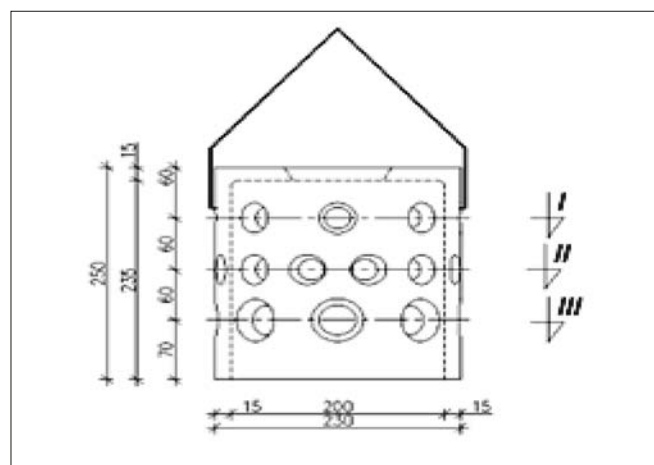

Fig. 2. Habitat module scheme

MATERIALS

According to the project, the following parameters of concrete and its mechanical properties were defined: exposure class XS2 (elements permanently immersed in the seawater), concrete class C30/37, concrete pH 8–8.5, waterproofness W8 according to PN-B_06250: 1988. The assumption has been made that production of the prefabricated elements used low-alkaline cement CEM I 42.5N HSR NA. The cement properties are presented in Table 1.

Tab. 1. Cement properties

Cement, type	Setting start time, [min]	Setting end time, [min]	Compressive strength [MPa]				Blaine fineness [cm ² /g]	Loss of roasting [%]	Water demand [%]	
			2 days		28 days					
CEM I 42.5N HSR NA	155	195	30.2		57.3		3504	3.4	27.5	
	Compound [%]									
	SiO ₂	Al ₂ O ₃	Fe ₂ O ₃	CaO	MgO	SO ₃	Na ₂ O _{eq}	K ₂ O	TiO ₂	Cl ⁽⁻⁾
	20.9	3.7	3.7	65.6	0.8	2.5	0.52	0.64	0.25	0.038
	Mineralogical compound [%]									
	Na ₂ O _{eq}		C ₃ S		C ₂ S		C ₃ A		C ₄ AF	
0.7		63.1		7.6		6.1		8.9		

It is assumed that the minimum exposure class must meet the same requirements as for XS2, and therefore, according to EN 206-1 the water/cement ratio must be $w/c \leq 0.45$, and minimum cement content must be 320 kg/m³. In the case of using traditional rebar, the rebar cover should be 5 cm thick. In this project it is defined that the maximum thickness of the ice layer on top of the water above the element will reach up to 0.4 m. We assume that the element will not undergo freezing and defreezing cycles.

After considering the conditions in which concrete construction XS2 will be working, and the EN 206-1 requirements, the concrete consistency was designed in class C35/45, consistency S2/S3, exposure class XS2, XC4, XF4, XA3, XS3, XD3. The physical properties of the aggregates are presented in Table 2.

In the project it was defined that the minimum concrete class will be C30/37 with the addition of polymer fibres (polyethylene and polypropylene mix), which can partly replace traditional rebar. The characteristics of the fibres required are: tensile strength $f_{ctm} > 380$ MPa, Young's modulus $E > 3.8$ GPa. The quantity of the fibres required is 1–3 kg/m³ of concrete. The fibres must be added to the concrete mix 30 min. before filling the form.

Generally, fibres used for concrete production can be divided into two groups: (1) shrinkage-resistant fibers which do not produce a reinforcement effect, and (2) fibres that partly replace traditional rebar. Fibre-reinforced concrete is a composite material with a cement matrix composed of cement grout, mortar or concrete with short-cut, dispersed steel, glass, carbon or plastic fibres [5–6]. It differs from ordinary concrete in having the ability of elastic deformations, so it is a very interesting material for varied applications. It is commonly used for prefabricated elements. However, for the production of typical concrete elements, traditional

rebar is more and more often being replaced by dispersed fibre reinforcement. Additional protection of the reinforced concrete surface by impregnation can significantly reduce the process of gas and liquid permeation [7–8].

Shrinkage-resistant fibres, added to a ready-mixed concrete, can play the role of a rebar, decreasing elastic shrinkage and limiting shrinkage cracks in the hardened concrete [9]. The length of these fibres ranges from 6 to 12 mm (Fig. 3). The addition of polypropylene fibres eliminates the need to use expensive and often ineffective steel-mesh shrinkage-resistant rebar. It can be applied for sprayed concrete, screed or grout. The fibres are characterised by shrinkage resistance $f_{ctm} < 370$ MPa and Young's modulus $E < 3.7$ GPa. The quantity of the fibres used in this case ranges from 0.6 to 1.5 kg/m³ of concrete. The fibre content prevents natural shrinkage cracks during setting and the initial period of hardening (about 24h), when the Young's modulus is low and the shrinkage stress exceeds its strength.



Fig. 3. Polypropylene shrinkage-resistant fibres

Tab. 2. Main particulars of the barge model

Fraction	Water absorption WA ₂₄ %	Volume density ρ_d [Mg/m ³]	Dried grain density ρ_{rd} [Mg/m ³]	Saturated grain density ρ_{ssd} [Mg/m ³]	Porosity P%	Crumble indicator X _r %	pH after 24 h	Bulk density in loose state ρ_b [Mg/m ³]
2/8	0.4	2.69	2.63	2.66	1.60	6.0	7.9	1.54
8/16	0.35	2.70	2.64	2.67	1.50	8.2	8.0	1.52

Steel fibres constitute a group of fibres intended for concrete reinforcement. They can occur as: straight or deformed elements of cold-drawn steel rod; straight or deformed fibres cut from a steel sheet; fibres produced as a result of an alloy; machined from cold-drawn steel rod or rolled from steel blocks. The length of the fibres usually ranges from 12 to 60 mm, with diameter up to 1 mm (Fig. 4).

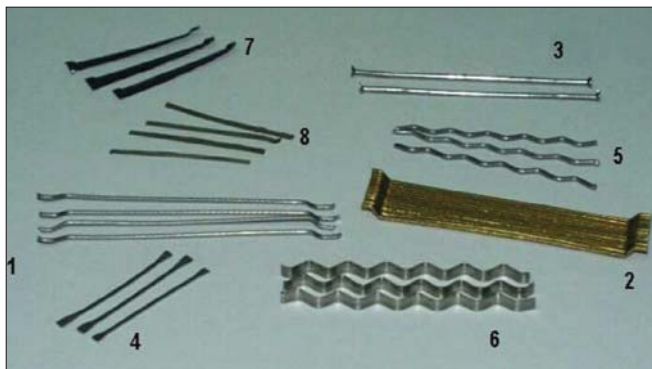

Fig. 4. Steel fibres for concrete (3, 8 – straight smooth, 1, 2, 7 – with racks on both ends, 4 – paddle-shaped, 5, 6 – wavy, 8 – straight. 2 – glued fibres)

Fig. 5 shows examples of constructional polymer fibres. Fibres of this type are resistant to water and aggressive environments.



Fig. 5. Polymer fibres for concrete reinforcement

Table 3 presents the mechanical properties of steel and polymer fibres. It appears that the concrete reinforcement effectiveness with 2 kg (11825 m) of 38 mm-long polymer fibres is much higher than with 20 kg (4000 m) of 50 mm-long steel fibres with the diameter of 1 mm.

The matrix of fibre-reinforced concrete itself is a brittle material, but the deformability limit of the dispersed fibres is significantly higher than the deformability of the matrix itself. As compared to high-strength composites, the percentage of dispersed fibre reinforcement is approximately 1–2% by volume. Even a relatively low content of the composite material enables significant modification of the concrete's properties. The apparent density of the cement grout ranges between 2000 and 2250 kg/m³, the Young's modulus is 10–30 GPa and the tensile strength is 3–6 GPa. The addition of fibres significantly changes its performance according to the characteristics of the fibre type used. Fibres can be dosed in different configurations and intermediate solutions (Fig. 6).

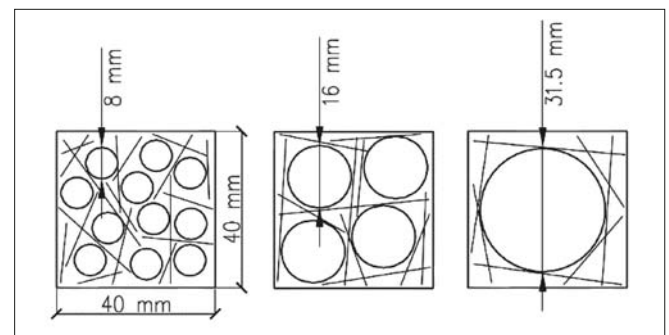

Fig. 6. Effect of fibre distribution according to size of aggregate

PRODUCTION

The elements were produced from concrete, the content of which is given in Table 4. The self-compacting concrete mix was modified with the chemical admixtures, providing liquid consistency. When placed directly into the forms, the mix did not require vibration.

Tab. 3. Physical and mechanical properties

Parameter	Fibre type					
	Steel				Polymer	
Density [kg/m ³]	7840				900-950	
Elasticity modulus [GPa]	200				6.5-7.5	
Tensile strength f_{ctm} [MPa]	500-2000				500-750	
Length [mm]	50	50	65	65	54	38
Diameter [mm]	0.6	1.0	0.75	1.0	0.45	0.45
Slenderness [l/d]	83	50	80	60	120	84
Quantity [pcs/kg]	8900	3200	4600	2700	110 000	156 000
Summary length [mb/kg]	445	160	276	162	5940	5928
Dosage [kg/m ³]	20				2	
Summary rebar length [m]	11125	4000	6900	4050	11880	11825

Tab. 4. Concrete ingredients

Ingredients	[kg/m ³]
CEM I 42,5N HSR NA	350-400
Water	144-150
Quartz sand 0/2 mm	550-650
Crushed Granodiorite 2/8 mm	350-450
Crushed Granodiorite 8/16 mm	650-750
Superplasticizer	0.9-1.2% cc
Plasticizer	0.7-0.9% cc
Air admixture	0.1-0.3% cc
Polypropylene fibre 12mm length	1.0
w/c	< 0.45
Air content in readymix [%]	4.5-5.5
fcm2 [N/mm ²]	36.7
fcm28 [N/mm ²]	59.2
fcm56 [N/mm ²]	66.9

Fig. 7 presents the elements in the storage of the prefabrication plant. About 7 days after production had been accomplished, the elements were transported to the construction site.



Fig. 7. The elements of the habitats in storage

After the extreme storms that took place in the Baltic Sea in 2016-2018, some of the elements were damaged. To define the reason for this damage it was necessary to perform concrete tests. Figs. 8 a, b show the elements placed on the bottom of the Baltic Sea.

METHODS OF TESTING

The objects tested were two damaged habitat elements set in the water at the bottom of the Baltic Sea for about 18 months. The aim of testing was to determine the concrete properties after the rather short period of concrete exploitation of the prefabricated element. Two damaged prefabricated elements (Figs. 9 a, b) were extracted to the sea shore. Drilling locations were selected and test specimens were taken.

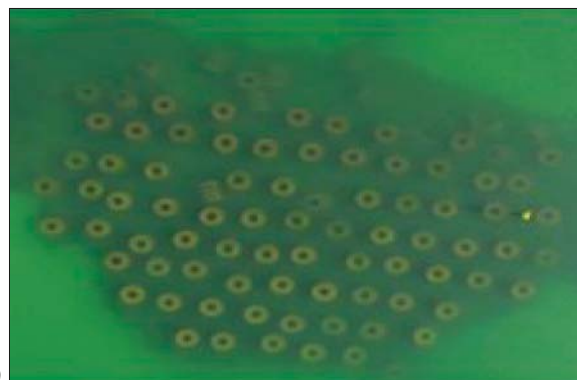
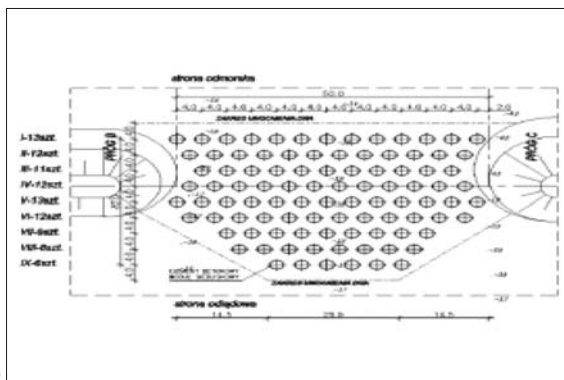

Fig. 8. Scheme of element placement a) according to the project ; b) at the Baltic Sea bottom



Fig. 9. Damaged elements under water

For test purposes, 24-cylinder specimens of 104 mm and 6-cylinder specimens of 144 mm were taken as core-drilled samples by cutting them out of the element with the use of a diamond blade cooled in water (Fig. 10).



Fig. 10. Concrete structure

After polishing the lower and upper surfaces of the specimens, the following was checked: surface flatness, straightness of the apex of the specimen and its perpendicularity (Figs. 11 and 12).



Fig. 11. Prefabricated surface



Fig. 12. Inhabited concrete element

The scope of testing:

1. A strength test was performed according to EN12504-1, EN 13971 and EN12390. The concrete class was defined in accordance with EN 206-1.
2. A waterproofness degree test was performed according to PN-88/B-06250. The degree of waterproofness was defined by means of defining a pressure indicator, which was calculated as the ratio of the height of the water gauge (m) to the thickness of the wall (m). The test was performed on cylindrical specimens of 144 mm and $h = 150$ mm. Before the test, the side surface of each specimen was covered with epoxide. The test was performed in a waterproofness testing device with regulated water pressure using clean water with a temperature of $18 \pm 2^\circ\text{C}$. The water pressure was increased by 0.2 MPa with the jump method every 24 hours, and the final pressure level of 0.8 MPa was maintained for 24 hours. In the course of testing, it was observed if there was any leakage on the side surface of the specimens. After the test had been completed, the specimens were broken with the aim of checking the depth of water penetration into the concrete.
3. A water absorption test was carried out on 5 specimens in accordance with the procedure described in PN-88/B-06250, which states that water absorption must not be higher than 5%. The specimens were put in a bath so that their bottoms did not touch the bottom of the bath (10 mm distance). The bath was gradually filled with water at a temperature of $18 \pm 2^\circ\text{C}$. On the first day, the water level was at half the height of the specimens. After another 24 hours, more water was added to a level 10 mm higher than the height of the specimens. This level was maintained until the end of the test. Every 24 hours the specimens were taken out of the water, their surface was dried and they were weighed (accuracy up to 0.2%). They were saturated with water as long as the next two weighing times showed a mass increase. Next, fully saturated specimens were placed in the dryer at a temperature of $105-110^\circ\text{C}$ and were dried till they obtained a steady mass. The mass water absorption was calculated according to the equation:

$$n_w = \frac{m_n - m_s}{m_s} \cdot 100\%$$

where n_w – mass water absorption of the specimen, m_s – specimen mass in dry state, m_n – specimen mass in water saturated state.

4. Chemical research was performed according to EN ISO 9963-1:2001, EN 1744-1:2000, and EN 1744-1:2000 concerning the concrete's pH definition, chloride content, sulphate content (given in SO_3) dissolvable in the water, and marking nitrate nitrogen by means of a colorimetric method with sodium salicylate.
5. Microscope tests were performed with a scanning electronic microscope (SEM) with the aim of defining the kind of cement and fibres used. The actual fibres dispersion in the fibre-reinforced concrete elements, as well as the actual fibres content can be checked on the basis of X-ray images or the elements crosscuts, analysed by means of stereological methods. The fibre dispersion layout is not

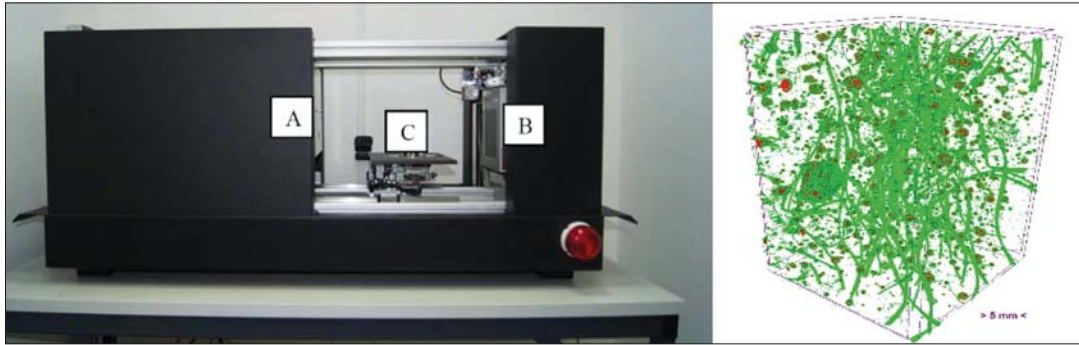

Fig. 13. a) Skyscan X-ray micro-tomograph: A - X-ray source, B- flat panel and C- precision object manipulator, b) X-ray - polymer fibre content test and polymer fibre dispersion test (example)

homogeneous. One innovative method of testing fibre-reinforced concrete is X-ray tomography (Fig. 13 a). In Gdansk University of Technology laboratory a test was done in which the degree of dispersion of polymer fibres in a cement matrix was designated by means of using X-ray micro-computed tomography. The high-energy table scanner SkyScan 1173 with a 130 keV microfocus X-ray source, flat panel sensor of large format (5 Mpx) with special protection by a lead-glass fibre-optic window for achieving a long lifetime under high energy X-ray was used. The scanner is additionally equipped with a precision object manipulator and integrated micro-positioning. It allows us to scan large and dense objects (Fig. 13 b). The X-ray source voltage of the micro-CT scanner was set to 130 keV, the current was 61 μ A and the exposure time was equal to 5000 ms. The pixel size of the micro-CT was 39.68 μ m. The X-ray projections were recorded with the rotation increment of 0.2° within 360°. To reduce the noise in the captures of the X-ray projections, the frame averaging option was set to 4 and the random movement option was 10. The scanning time was approximately 12 hours [10–11].

The tests were performed in Gdansk University of Technology, Civil and Environmental Engineering, Mechanics of Materials, Laboratory of Concrete Technology.

TESTS RESULTS

Strength tests were performed on 9-cylinder specimens of \varnothing 104 mm and h 100 mm by using the concrete compression testing machine Controls Advantest 9.

Compressive strength testing results:

quantity of specimens : n = 9

concrete volume density: 2380 [kg/m³]

minimum strength: $f_{m(n),is} = 53.7$ MPa

average strength: $f_{m(n),is} = 58.8$ MPa

characteristic strength for concrete class C35/45: $f_{ck} = 45$ MPa

Condition check: _____

condition I

$f_{m(n),is} \geq 0.85 (f_{ck} + 4)$

$58.8 \text{ MPa} \geq 0.85 \cdot (45 + 4) = 41.65 \text{ MPa}$

The condition is met.

According to EN 206-1:2003 Concrete Part 1. Requirements, Properties, Production and Compliance, the concrete meets the compressive strength requirements for class C35/45, whereas the class required in the project is C30/37.

In the course of the water permeation tests no leakage was observed in any of the specimens. The maximum depth of permeation under a water pressure of 0.8 MPa was 4.5 cm and the average depth of permeation was 3.7 cm. The concrete's degree of waterproofness was defined in accordance with PN-88/B-06250 W8.

The results of water absorption are:

Quantity of specimens: n = 5

Average specimen weight after soaking: 1828.6 g

Average specimen weight after drying: 1750.2 g

Average mass absorption: 4.5 % < 5%

Chemical tests of chloride ions (Cl⁻), sulphate ions (given in SO₃²⁻), nitrate ions (NO₃⁻) and pH content were performed in accordance with the standards given above. The content of chloride ions in the analysed specimens ranged from 0.020 to 0.022%. Sulphate content analysis (given in SO₃²⁻) did not show any excess content of those ions. 0.5% with regard to the concrete mass was defined as a borderline sulphates content. The results of the tests ranged from 0.009% to 0.012%. The given results are below the borderline mentioned above. The nitrate ions content (NO₃⁻) in the analysed specimens was at the marginal level (< 0.001%). The pH tests on the water extracts in the analysed specimens were performed by using the pH-meter WTW with the electrode SenTix42 type. The result was insignificantly above 10. The concrete structure showed an alkaline character without a carbonisation effect.

During the specimens check and microscope tests no traditional steel rebar was observed and no steel rods were found. Also, in the specimens taken from the element, no dispersed constructional fibres were found, increasing the flexural strength and resilience. During microscope tests, only 12 mm-long shrinkage-resistant fibres were found.

condition II

$f_{is,lowest} \geq 0.85 (f_{ck} - 4)$

$53.7 \text{ MPa} > 0.85 \cdot (45 - 4) = 34.85 \text{ MPa}$

The condition is met.

The characteristics of damage to the elements can be taken as proof that the reinforcement was not wrapping up. It is possible that instead of the construction fibre, shrinkage-resistant fibres were used.

CONCLUSIONS

On the basis of the tests, concrete class C35/45 was defined. Waterproofness tests confirmed that, according to PN-B/88-06250, the degree of waterproofness was W8. The concrete water absorption constituted 4.5%, whereas the maximum absorption according to the standard was up to 5%. Chemical tests showed that the concrete pH was higher than assumed (8–8.5) and constituted $\text{pH} > 10$ on the basis of the tests of water extracts taken from the specimens. Despite that, on the surface of the elements extracted from the water, plankton and phytoplankton were found. As a result of the testing, it can be stated that the concrete meets the requirements assumed in the project, concerning strength, water absorption and waterproofness. Microscope tests confirmed that clean concrete without additives was used, and the specimens check found no traditional rebar rods. During microscope tests no dispersed constructional fibres were found. However, 12 mm-polypropylene shrinkage-resistant fibres were present. The properties of the constructional fibres and those of the shrinkage-resistant fibres differ significantly and, therefore, they cannot replace one another.

SUMMARY

The example presented here of damage to prefabricated elements shows that high compression strength, low water absorption and high waterproofness are not sufficient parameters to ensure the concrete's durability and resilience. This concerns all types of constructional concrete placed underwater. It is, however, possible to modify the concrete by means of adding dispersed fibres, increasing both the flexural strength and resilience. The question of the choice of the appropriate type and amount of fibres and their influence on mechanical properties is being researched by many scientists [12–15]. A number of studies on fibre-reinforced concrete have been published, but a large number of issues have not yet been investigated. For instance, the amount of research into steel fibre-reinforced concrete is still significantly higher than into polymer concrete. It is well-known that the introduction of high-strength thin polymer fibres into the fragile matrix results in a new constructional material that is not comparable to concrete or steel-reinforced concrete. The presence of fibres changes the properties of the surrounding matrix. There are numerous benefits of using constructional fibres for concrete reinforcement. Among the most important are the 5 times higher flexural strength, increase of compression strength by 30% and tensile strength by 15%, more than 10 times higher resilience, increase of crack and wear resistance, decrease of shrinkage and creep by 30%, decrease of elasticity modulus

by 25%. In the analysed examples it would be recommended to use dispersed constructional fibres, which would increase the resilience of the concrete elements [16]. A proper content of fibres must be applied specifically to a given element with reference to the factors that influence its functioning. On the construction materials market, more and more additives are appearing that allow the modification of concrete properties. However, standards and detailed guidelines for designers are yet to be implemented. Therefore, a designer who wishes to use an innovative material has to be highly knowledgeable of its properties. Although the use of steel fibres significantly increases the mechanical parameters of concrete, exposure to moisture or chlorides may lead to corrosion and total sinking of fibres in the concrete. Consequently, the concrete surface will be damaged. It is recommended to use polymer fibres instead and either concrete surface impregnation or applying an epoxide layer [17].

REFERENCES

1. Semrau I. (1990): *Wpływ budowli hydrotechnicznych na brzeg morski*. Brzeg morski (1), Studia i Materiały Oceanologiczne, Nr 55, PAN Komitet Badań Morza, pp. 185-200.
2. Silvester R., Hsu J. R. C. (1997): *Coastal stabilization*, vol. 14, Advanced Series on Ocean Engineering, World Scientific, Singapore.
3. Martins G. M., Amaral A. F., Wallenstein F. M., Neto A. I. (2009): *Influence of a breakwater on nearby rocky intertidal community structure*. Marine Environmental Research, 67(4-5) 237-245.
4. Basiński T., Pruszek Z., Tarnowska M., Zeidler R. (1993): *Ochrona brzegów morskich*, Biblioteka Naukowa Hydrotechnika, No 17, IBW PAN, Gdańsk.
5. Mariak A., Kurpinska M. (2018): *The effect of macro polymer fibres length and content on the fibre reinforced concrete*. MATEC Web of Conferences. DOI:10.1051/mateconf/201821903004.
6. Kristowski A., Grzyl B., Kurpinska M., Pszczoła M. (2018): *The rigid and flexible road pavements in terms of life cycle costs*. Creative Construction Conference 2018. DOI:10.3311/CCC2018-030.
7. Pawelska-Mazur M., Kurpinska M. (2005): *Retrofitted VI bro-pressed pavement bricks and their impregnation in modern architecture*. Keep Concrete Attractive - Proceedings of the Fib Symposium 2005.
8. Li M., Li V. C. (2013): *Rheology, fiber dispersion, and robust properties of engineered cementitious composites*. Materials and Structures/Materiaux et Constructions, 46(3), 405–420.

9. Qiu J., Yang E. H. (2017): *Micromechanics-based investigation of fatigue deterioration of engineered cementitious composite (ECC)*. Cement and Concrete Research, 95, 65–74.
10. Luo H., Wu Y., Zhao A. (2017): *Hydrothermally synthesized porous materials from municipal solid waste incineration bottom ash and their interfacial interactions with chloroaromatic compounds*. Journal of Cleaner Production, 162, 411–419.
11. Skarżyński Ł., Suchorzewski J. (2018): *Mechanical and fracture properties of concrete reinforced with recycled and industrial steel fibers using Digital Image Correlation technique and X-ray micro computed tomography*. Constr. Build. Mat. DOI: 10.1016/j.conbuildmat.2018.06.182
12. Yoo D. Y., Banthia N. (2016): *Mechanical properties of ultra-high performance fiber-reinforced concrete. A review*. Cement and Concrete Composites, 73, 267–280.
13. Yoo D. Y., Banthia N., Yoon Y. S. (2016): *Predicting service deflection of ultra-high-performance fiber-reinforced concrete beams reinforced with GFRP bars*. Composites Part B: Engineering, 99, 381–397.
14. Yang J., Shin H., Yoo D. (2017): *Benefits of using amorphous metallic fibers in concrete pavement for long-term performance*. Archives of Civil and Mechanical Engineering, 17(4), 750–760.
15. Tabatabaieian M., Khaloo A., Joshaghani A., Hajibandeh E. (2017): *Experimental investigation on effects of hybrid fibers on rheological, mechanical, and durability properties of high strength SCC*. Construction and Building Materials, 147, 497–509.
16. Sideris K. K., Manita P., Chaniotakis E. (2009): *Performance of thermally damaged fiber-reinforced concretes*. Construction and Building Materials, 23, 1232–1239.
17. Kurpinska, M. (2011): *Properties of concrete impregnated using epoxy composition*. Roads and Bridges, 10(1-2), 59-80.

CONTACT WITH THE AUTHORS

Marzena Kurpińska

e-mail: marzena.kurpinska@pg.edu.pl

Gdańsk University of Technology
Narutowicza 11/12, 80-233 Gdańsk
POLAND

Beata Grzyl

e-mail: beata.grzyl@pg.edu.pl

Gdańsk University of Technology
Narutowicza 11/12, 80-233 Gdańsk
POLAND

Adam Kristowski

e-mail: adam.kristowski@pg.edu.pl

Gdańsk University of Technology
Narutowicza 11/12, 80-233 Gdańsk
POLAND