

**Marian Brzeziński**

marian.brzezinski@wat.edu.pl; NR ORCID:0000-0002-7123-7748

Military University of Technology, Faculty of Logistics, Institute of Logistics

# Military logistics versus civil logistics – similarities and differences

## *Logistyka wojskowa a logistyka cywilna – podobieństwa i różnice*

*The purpose of the paper is to carry out an identification analysis of military logistics and civil logistics as well as to determine similarities and differences. It characterises the nature of systemic approach in military logistics and civil logistics as well as analyses functional models of logistics systems of military organisations and industrial companies. It also presents the analysis of the features of logistics systems and a military organisation.*

*Key words: logistics system, military logistics, civil logistics, similarities and differences.*

*Celem artykułu jest analiza identyfikacyjna systemów logistyki wojskowej i logistyki cywilnej oraz określenie różnic i podobieństw. Scharakteryzowano istotę podejścia systemowego w logistyce wojskowej i logistyce cywilnej. Przeprowadzono analizę modeli funkcjonalnych systemów logistycznych organizacji wojskowych i przedsiębiorstw przemysłowych. Przedstawiono analizę cech systemów logistycznych przedsiębiorstwa i organizacji wojskowej.*

*Słowa kluczowe: system logistyczny, logistyka wojskowa, logistyka cywilna, podobieństwa i różnice.*

## 1. INTRODUCTION

The origin of logistics is undoubtedly military, which is underlined by almost all theoreticians studying this area. In the second half of the 20<sup>th</sup> century, civil logistics, upon the occurrence of objective conditions, has taken over and adapted some models used by the army, and then developed it in the economic theory and practice. It has also created its own logistics concepts and techniques, some of which have been successfully used in armed forces.

The division into military and civil logistics is symbolic and is related to the area of application. Military logistics is understood as its use in all kinds of military organisations, whereas civil logistics encompasses structures and its functioning in commercial organisations.

According to the author, even though logistics is a single concept, one can observe the artificial division into military and civil logistics, sometimes even treating them as separate areas. Military logistics and civil logistics have so far been developed separately to a certain extent, which causes that the idea of “civil” logistics usually presents indifference to logistics issues and relative indifference to the achievements of Polish and foreign military logistics.

It is reflected, for example, by the fact that university curricula in the field of logistics rarely encompass military logistics modules. Studies covering both civil logistics and military logistics are also scarce.

The purpose of the paper is to analyse the systems of military logistics and civil logistics as well as identify the differences and similarities of the logistics systems of military organisations and industrial companies.

## 2. SYSTEMIC APPROACH IN MILITARY LOGISTICS AND CIVIL LOGISTICS

Logistics, both in its civil and military incarnation, is understood ambiguously. There is also no generally adopted definition of logistics. Individual authors underline different elements in their definitions of logistics, referring both to the economic practice and the area of knowledge. Systemic approach is used both for military logistic and civil logistics. The systemic approach is a method of thinking and acting, encompassing principles and rights governing processes. It is characteristic for applied sciences like logistics, which does not have a uniform methodology – mainly the language, but, due to its multidisciplinary nature, having difficulty with explaining synthetic statements. The systemic approach is based on treating studies objects as open systems, that is, sets of elements connected in a way to form a new whole standing out from the environment [1,2].

Every organisation is a system and, whether a company or a state-owned entity, one can divide it into the OS operating subsystem and LS logistics system. The place and essence of the logistics subsystem in the system (of an organisation) is presented in picture 1.

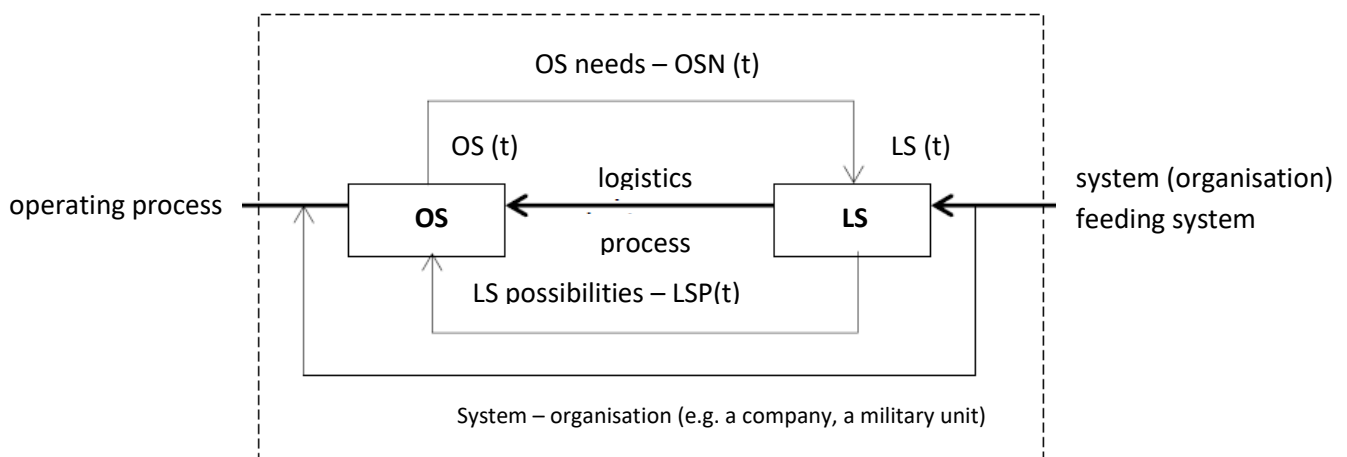

Figure 1. Place and function of the logistics subsystem in the system of an organisation.

An operating subsystem is guided by a basic process, which may involve, for example, the production of fixed property, army training or military action process. The functioning of an operating subsystem within its area of responsibility supports the logistics subsystem.

The OS operating subsystem, in order to fulfil its basic function, must have an adequate potential ( $P_o(t)$ ), which diminishes during the operation. Using up the potential of OS creates the need of replenishing it. Thus it generates certain  $OSN(t)$  needs that change with time in relation to the LS logistics subsystem, which, in turn, having particular  $LSP(t)$  possibilities, pursues the logistics process, regenerating the OS potential.

The LS logistics subsystem can be adjusted to the OS operating subsystem to a various extent. The adjustment of LS and OS subsystems can be determined with the use of  $\omega_D$  factor:

$$\omega_D = \frac{OSN(t)}{LSP(t)} \quad (1)$$

where:  $\omega_D$  – logistics to operating subsystem adjustment factor,  $O_{SN}(t)$  – the need of the operating subsystem in relation to the logistics subsystem;  $LSP(t)$  – possibilities of the logistics subsystem.

The adjustment factor may have the following values:

- $\omega_D = 1$  – full adjustment of LS to OS;
- $\omega_D < 1$  – excessive LS possibilities in relation to OS needs;
- $\omega_D > 1$  – excessive possibilities in relation to OS needs.

If  $\omega_D \neq 1$ , every such case will generate excessive costs of the system functioning. If  $\omega_D < 1$ , the logistics subsystem will be redundant, therefore its possibilities will be excessive in relation to the needs of the operating subsystem, which will result in high costs of the system functioning. At the same time the logistics subsystem will be flexible, which is desirable in the case of the fluctuations of the needs of the operating subsystem.

The logistics system is a concept that can often be found in publications. It is defined differently both in literature on the logistics of military and commercial organisations. Analysing the concepts of a logistics system of both military and commercial organisations, one can draw the following conclusions. The following elements can be identified in almost every definition: the purpose of the system, the elements of the system and system relations. Thus almost all of them meet the conditions of a classic concept of the system.

Usefulness is a significant feature of human actions and involves a conscious pursuit of specific goals and a belief that they can be achieved with the use of various methods. The fact of undertaking an action implies that they have consciously selected particular means

in order to achieve particular logistics goals. Due to the fact that they want to achieve these goals, they must represent certain value for them. The action takes place in a certain presence and is aimed at achieving certain logistics goals in the future. People do not know everything about the future, but they choose measures depending on the technological plan of the application of logistics processes in the presence and expect the achievement of the goals in the future. It is particularly important for military organisations under military action conditions, where it is very difficult to obtain precise, up-to-date, complete and proper information. People's activity within logistics system results from the scarceness of measures, as opposed to desirable logistics goals. Goals of logistics systems in commercial organisations and military organisations are different. The conditions for achieving them, both internal and external ones, are also diverse. Logistics operations can be performed within a certain range of conditions, from stable to chaotic ones. In commercial organisations, chaos will be related to the economic crisis, whereas in military ones – to military conditions. The operation of every logistics system is based on the achievement of set goals.

The goal of a logistics system is achieved on the basis of decisions (actions). A set of acceptable actions is identified as:

$$Q = \{q_i, I = 1, \overline{L}\} \quad (2)$$

where:  $q_i$  – acceptable functioning of the system.

Decisions made affect the result of the system's functioning.

The level of achievement of the set goal is assessed with the use of various analytical tools in the form of the so-called goal function. The most common goals include: effectiveness, efficacy, efficiency, minimum profit, minimum time, maximum capacity etc.

The function of a goal assigns to every final result of the system operation a specific value that characterises this result:

$$K = \{k_n, n = 1, N\} \quad (3)$$

where  $k_n$  – the result of the system operation.

If we assume that we can assign only one element of  $k_i \in K$  set to every element of set  $q_i \in Q$ , it means that a certain function  $f$  has been specified in set  $Q$  that assumes values from set  $K$ , that is:

$$f: Q \rightarrow K, k = f(q) \quad (4)$$

Function  $f(q)$  is called the function of the operation result. The aim is to find an optimum (extreme) operation  $q^* \in Q$ , where  $f(q^*)$  is optimum.

$$q^* \in Q, f(q^*) = \underset{q \in Q}{\text{extr}} f(q) \quad (5)$$

One should therefore choose from set  $Q$  a system operation strategy that that would generate an optimum final result. If there are at least two elements making an optimum result in set  $Q$ , additional criteria can be used in order to eliminate possible operations.

The operation can be: effective, but unfavourable; ineffective but favourable; effective and favourable (it is an example of effective operation); ineffective and unfavourable.

Elements of logistics systems may include: things, processes and events. Things are understood as any separated, relatively durable, material element of nature, where nature is understood broadly, including people and the products of their material activity. A process is defined as any sequence (streak, chain) of changes occurring in subsequent or overlapping moments, intentionally distinguished in some respect as a certain whole. An element is the smallest functional part of the logistics system. Further division of the elements of logistics systems lead to the loss of their function. Elements of which logistics systems of military organisations are built are the same as elements of commercial organisations, e.g. trucks, forklifts. Yet, logistics systems of military organisations include a number of elements that usually do not occur in civil logistics systems, e.g. field kitchens, missile reloading equipment, armoured recovery vehicles, operating theatres. Transfer relationships and connection relationships are distinguished between elements of the logistics system.

Relationships are: relationships and/or links (interactions, influence). Transfer relationships and connection relationships are distinguished between elements of the logistics system. Transfer relationships are related to fixed property and information circulating in the logistics system, and they determine the relationship between input and output. Moreover, important relationships in logistics systems include the relationships of subordination through

the system purpose as well as support relationships determining the order, so that it is known which subsystem (element) serves the subsystem (element) that has been singled out.

The number of relationships  $R$  in the function of the number of elements  $e$  can be determined based on the following relationship:

$$R = e \cdot (e - 1) \quad (6)$$

Transfer relationships are related to the flow of streams of fixed assets and information. Military and civil logistics systems include both feeding streams and waste streams. The direction, composition and intensity of the streams flow are different in the systems of military logistics and civil logistics.

Combining the elements in a specific way and arranging them by purpose, one can create systems, processes, chains or logistics networks that are also systems. Logistics systems of both military and commercial organisations are arranged hierarchically.

Logistics systems of military and commercial organisations, irrespective of their size, have boundaries that separate them from the environment. The boundaries of logistics systems are hard to define, they are blurred and the surrounding penetrates the system in many ways. The environment is a fragment of the reality that is not part of the logistics system, but affects its behaviour. It is a system made of elements linked by relationships, more complex than the logistics system, dynamic and less predictable. This influence is performed with the use of entries into and exits from the system. Entries cover all ways in which the environment influences the logistics system, and exits – the way the system influences the surroundings. Elements of the environment such as the economic system, the legal system, the market or the logistics infrastructure, which are also a ground on which military and civil logistics systems are integrated, have the greatest impact on the functioning of the logistics system.

### **3. THE ANALYSIS OF THE FUNCTIONAL MODEL OF THE LOGISTICS SYSTEM OF MILITARY ORGANISATIONS**

The logistics system of a military organisation can be defined as a set of management and executive bodies linked by information and supply relationships, designed to maintain the continuity of logistics processes carried out for its own and allied armies. The functional graphic model of the logistics system of a military organisation is presented in figure 2.

A logistics system of military organisations (LSMO) is a bridge between the national base system (NBS) and the operating system of a military organisation (OSMO). The logistics

system of a military organisation covers, from the functional point of view, all processes carried out in time and space between the national base systems and the operating system of a military organisation as well as steering, regulation and control systems. Steering and regulation takes place due to the fact that the adopted criteria of the effectiveness and efficacy of a given system are met.

The functional logistics system model is divided into the following subsystems: logistics management (LMS) and executive: material supply and service subsystems combined with the material evacuation process form material protection (MPS), technical fitness restoration (TFRS) and medical aid (MAS) subsystems, in which quality and quantity transformation feeding streams and waste streams of the operating system of a military organisation takes place. The space between the national base system and the operating system of a military organisation is covered in the time function by the transportation (TS), technical evacuation (TES) and medical evacuation (MES) subsystems, which make the streams flow. Moreover, in the feeding channel of the operating system of a military organisation, one can identify mainly streams of material resources and services  $S_M(t)$  and of repaired weaponry and military equipment  $S_{OT}(t)$  as well as cured injured and sick people  $S_W(t)$ . The two later streams have undergone qualitative transformation in TFRS and MAS. In the SOOP waste channel, there are streams such as: technical evacuation  $S_{ET}(t)$ , medical evacuation  $S_{EM}(t)$  and the evacuation of materials, packaging, cartridge cases, left and defective equipment – carried by vehicles or people etc. Moreover, there is information circulation in the form of streams of needs  $I_P(t)$ , tasks  $I_Z(t)$ , reports  $I_M(t)$  and cooperation  $I_W(t)$  in the logistics system steering subsystem.

The national base system includes mainly: resources, defence industry entities, repair establishments, hospitals etc., where production, warehousing, transport, medical, technical equipment repair, information and other processes are carried out. In the national base system, there are sources of streams feeding the operating system of military organisations and the outlets of the waste streams of the operating system of a military organisation.

The operating system of a military organisation divided into military formation, fire delivery and combat support subsystems carries out training, delivery and movement processes. In order to enable the above-mentioned processes to be carried out, the operating system of a military organisation generates specific logistics needs related to the national base. At the same time, during the implementation of training, delivery and movement processes, specific waste of the operating system of a military organisation are produced. System waste includes the material of the operation system that is not consumed in the

operation process. There is operating waste, which covers objects of the system operation that have not been used up, and exploitation waste – subjects of the system operation and intermediaries of the system operation. Subjects of the operation may include people or teams of people, whereas the objects of the operation cover mainly biological and technical objects. Waste coming from the operating system of a military organisation includes: medical loss, technical loss, unnecessary means of supply, packaging, cartridge cases, secondary raw materials etc.

#### 4. THE ANALYSIS OF THE FUNCTIONAL MODEL OF A LOGISTICS SYSTEM OF AN INDUSTRIAL COMPANY

The concept of a logistics system of a company is understood as: “... a set of management and executive bodies linked by relationships, intended for the processing of the delivery stream in line with customer requirements”.

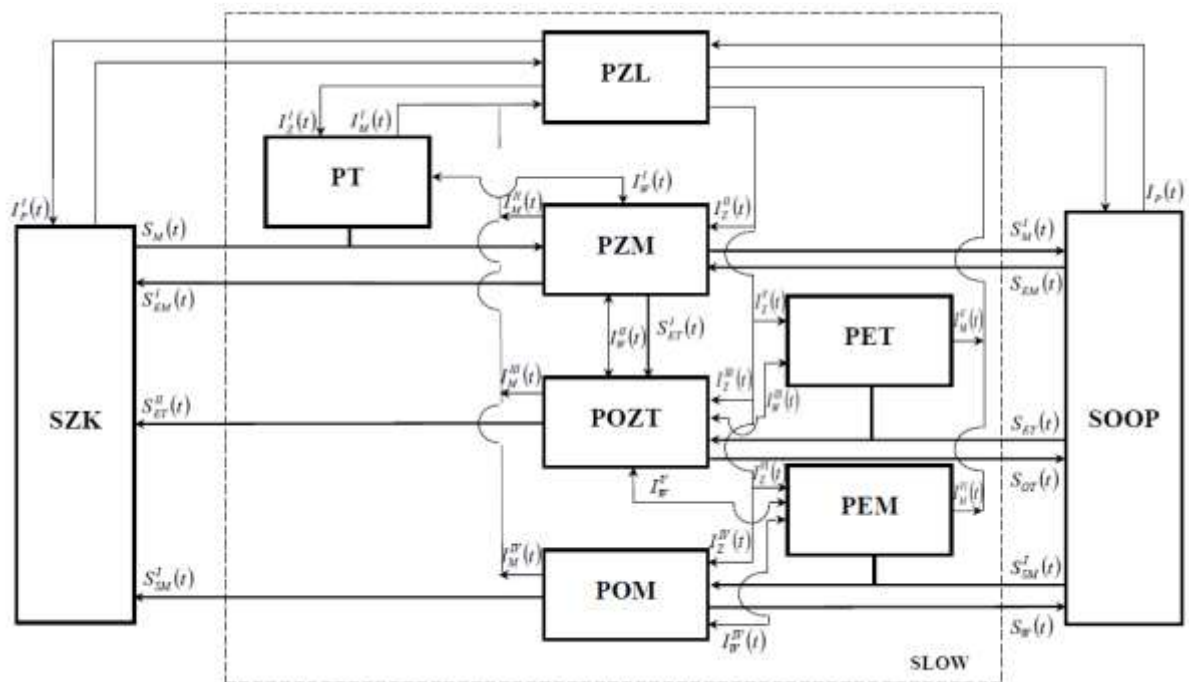

Figure 2. Functional graphic model of a logistics system of a military organisation

The model of the logistics system of a functional industrial company – figure 3 consists of the following subsystems: logistics management (LMS) and executive: supply logistics (SLS), production logistics (PLS), distribution logistics (DLS) and system waste logistics (SWLS), in which the qualitative and quantitative transformation of delivery streams and waste streams occurs. In the logistics system of an industrial company, we can identify



the following streams: company supply  $S_z(t)$ , production supply  $S_{zP}(t)$ , ready products  $S_{wG}(t)$ , sales  $S_s(t)$  and system waste  $S_{oz}(t)$ . Moreover, the management system is linked to information relationships with executive subsystems and the environment. One can distinguish mainly the following information streams: tasks for executive subsystems  $|I_{\frac{Z}{Z}}(t), I_{\frac{P}{Z}}(t), I_{\frac{D}{Z}}(t), I_{\frac{O}{Z}}(t)|$ , reports of executive subsystems  $|I_{\frac{Z}{M}}(t), I_{\frac{O}{Z}}(t), I_{\frac{P}{M}}(t), I_{\frac{D}{Z}}(t)|$ , cooperation  $|I_{\frac{I}{W}}(t), I_{\frac{II}{W}}(t), I_{\frac{III}{W}}(t), I_{\frac{IV}{W}}(t)|$  and the relationship with the environment: possibilities of the supply market  $I_{mZ}(t)$ , selling off possibilities  $I_{mZB}(t)$ , the company's needs related to supply  $I_{pZ}(t)$  and sales possibilities  $I_{pZB}(t)$ .

## 5. THE ANALYSIS OF THE FEATURES OF LOGISTICS SYSTEMS OF A COMPANY AND A MILITARY ORGANISATION

The differences and common features of the logistics of an industrial company and military organisation can be identified with the use of a systemic approach. It makes it possible to describe and compare diversified systems, that is, logistics systems of a military organisation and a company [3].

In order to determine differences and common features of the logistics systems of a military organisation and a company, the identification analysis method was used and a comparison was made in several aspects: goals, system structure, processes, management structures, operation conditions, assessment criteria. A list of the characteristic features of the logistics system of a company or a military organisation is presented in 0.

The logistics system of a particular commercial organisation, which is both a company and, to a great extent, a military organisation, largely depends on the type of the core activity. The purpose of a company's activity is to gain profit obtained as a result of the sale of developed products or/and services. Military organisations are also a kind of a company that carries on training activity in peacetime, whose purpose is to "produce" the capacity and readiness of the army to act in peacetime or to support peace. In peacetime, apart from the training activity, military organisations carry out business operations aimed at maintaining the army and ensuring their training. Most business tasks are also performed by the logistics division of military organisations.

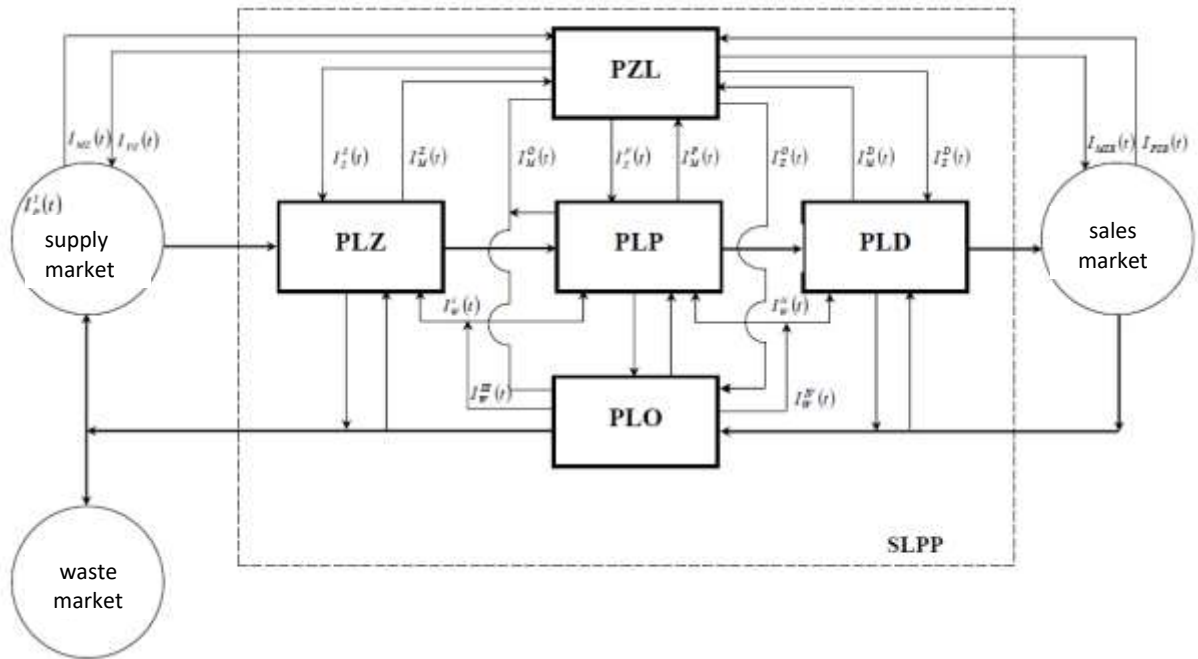

Figure 3. A functional graphic model of the logistics system of an industrial company.

Table 1. A list of characteristic features of the logistics systems of a company or a military organisation

Logistics system of an industrial company	Logistics system of a military organisation
<b>Purpose</b>	
Satisfying the needs of recipients in the company and customers in the market.	In peacetime: maintaining and ensuring the army training process and securing efforts to support peace.  In wartime: logistics support of military actions.
<b>Logistics system structure</b>	
Logistics subsystems: supply, production, distribution, system waste, management.	Logistics subsystems: material, technical, transport and army movement, medical, army infrastructure, management and command.
<b>Logistics processes</b>	
transport,	

warehousing, reloading, packing and labelling, technical equipment operation, energy supply, waste management, management.	
	medical support, exploitation of local resources and spoils of war, securing the needs of prisoners of war, burying those killed in action and deceased soldiers.
<b>Stock management</b>	
Minimising the stock level	Necessity of maintaining war stock
<b>Selection of suppliers</b>	
Unlimited selection possibilities	Limited selection possibilities
<b>Organisational structures</b>	
diverse and unique, diverse situation of the logistics manager, various procedures, principles and documents.	unified, common, hierarchical, identical situation of the logistics manager, standard procedures, principles and documents.
<b>Operation conditions</b>	
Usually stable, apart from critical situations	Often very difficult under wartime conditions
<b>Main system assessment criteria</b>	
In the peacetime:	
effectiveness	
In the wartime:	
effectiveness	efficacy

Source: M. Brzeziński, *Systemy w logistyce*, WAT, Warsaw 2007, p. 135-136

As in the case of the logistics of armed forces, its purpose is to create the usefulness of the place and time. Logistics ensure the usefulness of place by moving goods to places where there is still demand for them. The usefulness of time, on the other hand, is created by

logistics through the maintenance of appropriate stock level and distribution of goods. The purposes of logistics systems in a company and in military organisations are different.

The purpose of a logistics system is to satisfy the needs of the production process and services as well as customer service in the markets.

The purpose of the operation of a logistics system of military organisations is different in peacetime and in wartime. In peacetime, the fundamental purpose of the logistics system is to maintain and secure the army training process and to secure efforts to support of peace, and in wartime – logistics support for military action.

Logistics systems of a company and of armed forces differ in structure. In the logistics system of a company, the following subsystems usually occur: supply, production, waste management distribution and returns. In the logistics system of commercial organisations, on the other hand, there are material, technical, transport, medical and military infrastructure subsystems.

Processes applied as part of logistics systems of military organisations and of a company coincide partially. They include transport, warehousing, reloading, packing, goods labelling and other processes, such as medical support for the army, exploitation of the resources of the local spoils of war, satisfying the livelihood needs of prisoners of war or burying those killed in action and deceased soldiers.

The functioning of logistics systems of military organisations and companies differ also in particular areas of performed tasks. Fundamental differences are mainly related to stock management and selection of suppliers.

Stock management is a very important problem both for companies and for military organisations. Stock not only occupies certain space, but there is also capital frozen in them. Companies and military organisations differ in their approach to stock management. The basic rule of stock management in a company is minimization. Military organisations gather and maintain current stock and war stock. As regards current stock, there are certain possibilities of streamlining their level. War stock, on the other hand, must be absolutely maintained at a particular level and range.

Companies have practically unlimited possibilities of selecting suppliers. The following criteria are usually taken into account: location of the supplier, reliability of supplies, timeliness of supplies, quality of material, price and extra services offered by the supplier. There are certain limitations in the selection of suppliers for military organisations. In the case of typical military goods, the number of purchase sources is limited. They are chosen not only based on military and economic factors, but also on political ones, most of

which are independent of armed forces. Military organisations have greater possibilities of purchasing consumer goods. Such purchase is subject to the provisions of the Public Procurement Act irrespective of the type of goods.

Logistics management structures occur on every organisational level of armed forces. They are characterised by uniformity and strict vertical connection. They are regulated by standard procedures, principles and documents. Hierarchical situation of post holders of the logistics division at every organisational level is also uniform. Logistics structures are not common in companies. If logistics structures do occur, considerable differences may occur between them, mainly depending on the type of business operations of a company. The hierarchical situation of the manager as a person responsible for logistics processes is also greatly different.

The differences between conditions in which both systems operate are also noteworthy. The conditions in which a logistics system of armed forces operate during actions to support peace or military actions are very difficult. In such cases, the logistics system of a military organisation usually works remotely from its country of origin, often under the influence of the enemy. The logistics system of a company works in normal conditions, and the instability of its operation can be caused by the dynamics of changes in the environment (stability – chaos).

There are also differences in the criteria of the assessment of the logistics systems of a company and military organisations. The logistics systems of a company and military organisations functioning in peacetime can be assessed with the criterion of the cost-effectiveness ratio. It is based on the minimisation of costs, maintaining the desired level of customer care, no matter if it is an individual customer, another company, a soldier or a particular military structure. Other criteria are used for the logistic assessment of military organisations during the war. In this case, it is assessed with the use of the criterion of effectiveness and reliability of the logistics support of the army's needs.

The identified differences and common features of the logistics systems of a company and military organisations does not exhaust the entire set. However, they are crucial and show the specificity of each logistics system, resulting mainly from the difference between the purposes of operating systems of organisations.

## **5. CONCLUSION**

The study of military logistics and civil logistics was carried out with the use of systemic approach. It made it possible to describe and compare diverse logistics systems of military organisations and commercial organisations, using consistent terminology and comprehensively taking into account various relationships in the description of the studied logistics systems, and to identify the differences and similarities that have so far been less recognizable. The studies have been carried out with the use of praxeological models. Models of logistics systems are presented in the form of descriptions and graphically. They are used to analyse the logistics systems of military organisations and industrial companies. It has been found that the greatest differences include the purposes and structures of the logistics systems of military organisations and industrial companies. Similarities, on the other hand, have been identified in some processes that are the same in both the military logistics and the civil logistics.

#### **BIBLIOGRAPHY:**

Brzeziński M. (ed.), Modelowanie systemów i procesów logistycznych w aspekcie technologii podwójnego zastosowania, WAT, Warsaw 2018.

Brzeziński M. Systemy w logistyce, WAT, Warsaw 2007.

Brzeziński M., Inżynieria systemów logistycznych, WAT, Warsaw 2015.

Kłodawski M., Modelowanie procesów magazynowych w zastosowaniu do oceny wydajności i bezpieczeństwa pracy w magazynach, , Oficyna Wydawnicza Politechniki Warszawskiej, Warszawa 2018.

Lewczuk K., Modelowanie procesów w systemach magazynowych w zastosowaniu do oceny niezawodności i efektywności ich funkcjonowania, Oficyna Wydawnicza Politechniki Warszawskiej, Warszawa 2016 r.

Świdorski A., Józwiak A., Jachimowski R. (2018). Operational quality measures of vehicles applied for the transport services evaluation using artificial neural networks. *Eksploat-acja i Niezawodnosc – Maintenance and Reliability* 2018; 20 (2):2920299

Wasiak M., Jacyna M., Lewczuk K., Szczepański E., The method for evaluation of efficiency of the concept of centrally managed distribution in cities. *Transport*, 2017, 32(4): 348–357

Waśniewski T., Monitorowanie zasobów logistycznych z wykorzystaniem inteligentnych metek RFID w oparciu o sieć bezprzewodową. Zarządzanie w przedsiębiorstwie, XIV Międzynarodowa Konferencja Naukowo-Techniczna, Wyd. WIPMiFS Politechniki Częstochowskiej, Częstochowa 2006.

Waśniewski T., Śledzenie zasobów logistycznych w oparciu o technologię RFID z wykorzystaniem sieci bezprzewodowej. 1st INTERNATIONAL CONFERENCE OF LOGISTICS INTLOG 2006, Czasopismo Logistyka nr 5/2006, 1CD .

Waśniewski T.R., Ślaski P., Modelowanie procesu automatycznego rozpoznawania i identyfikowania pojazdów w oparciu o technologię RFID. Gospodarka Materiałowa & Logistyka nr 5 CD, Warszawa 2018.

Żak J., Jacyna-Gołda I, Wasiak M., Effectiveness evaluation criteria of the functioning of the national transport system and its impact on the environment. Simulation model to support designing a sustainable national transport system. 2014.

Żak J., Modelowanie procesów transportowych metodą sieci faz. Oficyna Wydawnicza Politechniki Warszawskiej, Transport 99, Warszawa 2013.

Żak J., Parametryzacja elementów procesu transportowego. Logistyka 4/2011.

Żak J., Wybrane aspekty dynamiki procesu transportowego. Oficyna Wydawnicza Politechniki Warszawskiej, Transport z 97, Warszawa 2013.