

EXPERIMENTAL STUDIES OF A MOVEABLE WALL TO A SHOCK WAVE

Aleksander Górniak, Andrzej Kaźmierczak

Wroclaw University of Technology
Department of Motor Vehicles and Combustion Engines
Braci Gierymskich 164 Street, 51-640 Wroclaw
tel.: +4871347 79 26, fax +4871 347 79 18
e-mail: aleksander.gorniak@pwr.wroc.pl, andrzej.kazmierczak@pwr.wroc.pl

Abstract

This paper explains the experiment conducted in order to reveal the response of a movable wall on a shock wave generated by ignition of a pyrotechnic gas generator dedicated for the automotive industry. This same kind of a pyrotechnic gas generator was used in each test. The test station consists on a pyrotechnic actuator in which the movable wall is expressed as a piston. The pyrotechnic actuator was specially design for such type of an investigation. Its design allows withstanding numerous tests without affecting the accuracy, and it is prepared to pressure measurement in three locations on the cylinder. However, here only the pressures measured in the vicinity of a cylinder bottom are under deliberation. This paper focusses on a shape of the piston influence on its movement characteristics (i.e. stroke velocity and acceleration). The experiment has shown that there is an influence of the shape of the movable wall on its movement characteristic. Furthermore, the experiment explained here constitutes a comparison of a piston velocity and acceleration with a flat and concave front surface. The dynamic pressure measurement have proven that the reflected shock wave increases its speed affecting the piston movement.

Keywords: pedestrian protection, pyrotechnic actuators, shock wave

1. Introduction

Pyrotechnic actuators are widely used in automotive industry due to the fact that such a construction provides very short time of reaction. Furthermore, pyrotechnic actuators are able to produce large amount of energy not requiring much space to store. Mostly such a devices are used in pyrotechnic seat belts pretensioners, in pop-up hood system for pedestrian protection, systems that open doors of crashed vehicles in order to provide easier access to the injured occupants etc. The pyrotechnic actuators differs from each other mainly with size ranging from micro actuators for aerospace industry to the actuators whose cylinder have 20 cm diameter. Such constructions are used for instance to emergency gates close/open [1] [1] or like it is pointed out in publication referred under [2] for an emergency landing scenario for the space shuttle. This particular actuator has length of 33 cm with piston fully deployed.

The piston of the pyrotechnic actuator is trusted forward upon the ignition of the pyrotechnic charge. This pyrotechnic charge produces a large amount of gases as combustion products in the time of milliseconds. The ignition of the charge therefore generates a wave, which acts on the piston forcing it to advance forward. The shock wave in terms of pyrotechnics is defined as a pressure wave of high intensity characterised by a very rapid initial increase in pressure followed by a slow falling off [3]. This wave is reflected by the piston, and then reflected back again by the bottom of the cylinder. This process (i.e. number of the reflection) depends on the wave velocity, and therefore energy. The repeatable reflection causes weakening of the reflected shock wave while the compression waves still propagates forward. Ultimately, both of the waves will coalesce and form a new shock wave in front of the wall [4]. It has been found that the actuator operation and acoustics timescales are very

similar (in the order of approximately $0 \mu\text{s}$). This suggests that wave interaction may influence the performance of the device [2]. The shape of a shock wave has an influence on the speed with which it travels. Generally, the detonation of a charge is dependent on the detonation wave velocity, the radius of a charge, and the shape of a wave front [5]. Thus, it is possible to influence the performance of the device with appropriate forming the shape of the shock wave. Most of actuators design, however, constitutes a piston with flat surface as well as flat death bottom centre. Very often, the pyrotechnic gas generator is located on side of the cylinder; in consequence, the flow is directed from the cylinder with smaller diameter into the main, larger chamber. Such a solutions significantly mitigates the energy of a pyrotechnic gas generator, hence some potential is lost. This may cause of longer time required for the piston full deployment or necessity of employing gas generator with greater power [6].

2. Shock wave reflection phenomenon

The numerical investigation of shock wave properties reflected from the cylindrical reflector has been performed by Henshaw et al. [9]. What was investigated was the shock wave with various Mach number reflected from the circular reflector. The shock wave was divided in to the weak and strong wave. It appeared that only the strong shock wave (i.e. shock wave propagating with relatively high Mach number) are influenced by shape of the reflector. In case of weak shock wave, this relationship is rather not important. The reflected shock wave generates so-called shock-shocks at location being dependant on the shock wave Mach number and the curvature of the reflector. The shock-shocks arises as a consequence of shock wave reflection from the concave wall towards the centre of the chamber and arise from discontinuities in the shock front [8]. In other words, the shock-shocks is a 3D equivalent of the 2D triple points. It has been found that the Mach number can be significantly increased at the point of shock-shocks occurrence. The increase can be significant enough for the weak wave to be considered as a strong one. Similar behaviour has been observed by Johansson et al. [8]. They had investigated the possibility to form a specific shape of the shock wave enclosed in the confine polygonal space. This investigation has proven that the shock wave can be formed in the way to resemble shape of the reflector. In this investigation, polygonal shape of a shock wave was obtained with corresponding location of the shock – shocks. Hence, the energy of the shock wave is changed with accordance to the shape of the reflector. Moreover, Gui et al. [9] investigated the shock wave reflection from the planar and cylindrical wall of a shock tube. It appears that the shock wave reflected from a planar surface has lower velocity comparing with the shock wave reflected from the concave wall. This suggests that the wave reflected from concave surface is capable of maintaining during longer period of time, hence to perform the work (i.e. piston movement) [6].

3. The test station

The experiment consisted on a shock wave impact on a movable wall (in this case a piston) determination. The experiment required several repetition of the tests in order to accurately prove occurring relationships. For this purpose, an actuator capable of withstanding multiple testes not affecting the accuracy was designed (see Fig. 1).

The design of this actuator enables installation of a piston with variety of shapes. Here it is done by the employment of piston inserts with flat (Fig 2. a) and concave (Fig. 2 b) surface. Those inserts were fixed with the piston and the piston rod by a pin, which was designated to be a weakest link in the system. When the velocity of a piston was great enough to damage the actuator, the pin was be cut-off significantly disconnecting the piston from the piston rod reducing the momentum. This is done in order to prevent damage of the test station, and therefore ensure reliability of the test.

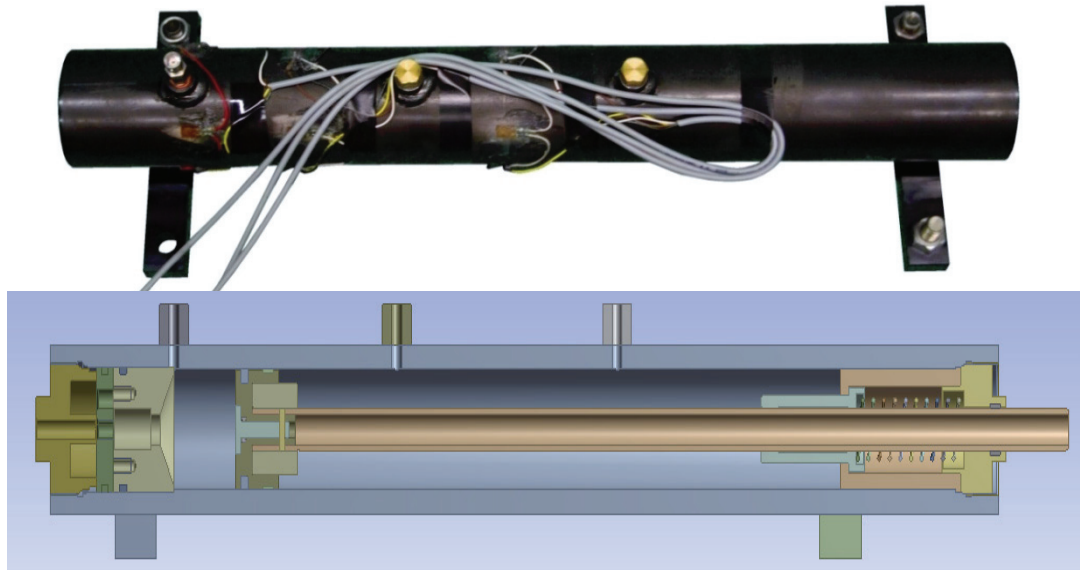

Fig. 1. The pyrotechnic actuator used for the tests

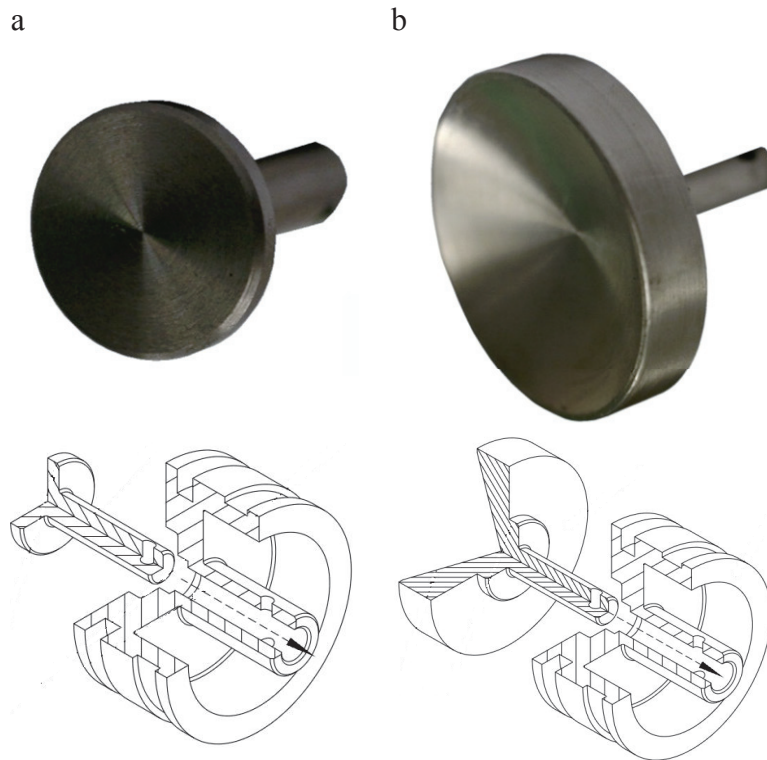

Fig. 2. The piston inserts and their installation; a – flat surface, b – concave surface

The experiment assumed measurement of pressure existing within the chamber between the cylinder bottom and the piston. Here the pressure was measured by means of a quartz pressure sensor (KISTLER 601H) dedicated mainly for the ballistic purposes [11]. The seating for the pressure sensor is shown in Fig. 3. Taking into consideration the fact that a shock waves reflecting from a cylindrical surface increases their speed in the extant allowing a weak wave to become a strong one [12], [13] the sensor is set to measure dynamic pressure. This will cause the measurement of a first pressure wave that will be detected by the sensor. All tests were performed with the utilisation of a gas generator this same kind, however different velocities of a reflected shock wave causes different pressure readings.

In order to ensure constant initial volume (before the ignition of a pyrotechnic charge) the piston was moved for some distance forward in the case of the test with concave piston surface. The mass of the insert – piston – piston rod system was kept constant by installation additional of a member witch compensates the difference of masses in two pistons embodiments. The piston velocities were elaborated basing on records captured by a Phantom v12 high-speed camera and with the aid of TEMA Automotive software.

The experiment assumes three repetition of the test with a piston equipped with each of the inserts. Furthermore, the results of those tests are confronted with each other.

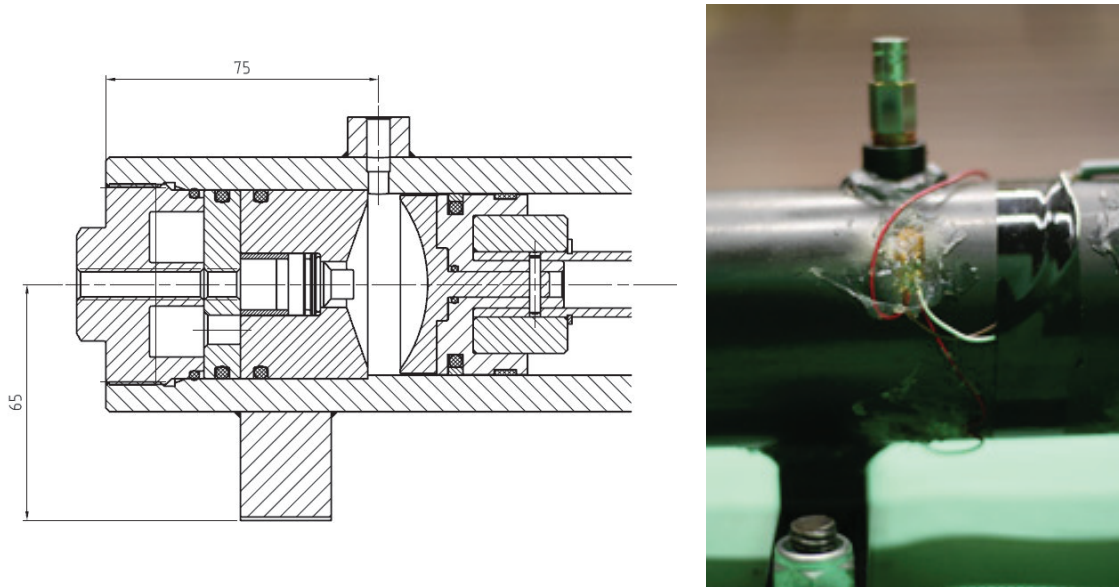

Fig. 3. Seating for the pressure sensor; (dimensions in millimetres)

4. Results and discussion

The results of the experiment satisfies the expectations assumed basing on the literature knowledge. It appears that installation of the concave piston surface does affect the actuators performance. The difference is in both velocities as well as in the case of measured dynamic pressure. Tab. 1 shows the comparison of maximal velocity as well as time and a distance after which the maximal velocity was obtained along with the maximal pressure within a combustion chamber of the pyrotechnic actuator. It appears that the dynamic pressure in case of the concave piston surface is greater for about 40 bars comparing with the flat piston surface. This would indicate a significant increase of the reflected shock from the concave piston. Moreover, it appears that the concave piston traveling with speed greater for about 2 m/s.

Tab. 1. Results of three repetitions of the tests of a piston with different shape

Test repetitions	Flat piston surface				Concave piston surface			
	T, ms	L, m	V, m/s	P _{max} , bar	T, ms	L, m	V, m/s	P _{max} , bar
1	8.7	0.140	22.46	105.59	8.3	0.161	24.30	153.97
2	8.3	0.143	22.64	108.16	9.0	0.176	24.40	145.71
3	7.9	0.130	21.37	110.34	8.3	0.160	24.37	147.66
Average value	8.3	0.138	22.16	107.36	8.5	0.166	24.35	148.08

Taking charts representing an average piston velocity with respect to the swept distance shown in Fig. 4 it appears that the concave piston surface exhibits different movement characteristics. In case of concave piston surface (Fig. 4 b) the velocity gradient is steeper than in the case of a test of a pyrotechnic actuator with a flat piston surface (Fig. 4 a). This suggests greater acceleration. Furthermore, the concave piston reveals the tendency to an earlier start comparing with the other embodiment of the piston. However, it should be mentioned that the slow motion record analysis revealed a significant vibration of the piston rod when the concave piston surface was under investigation. This vibration was noted in every of three repetition of the tests. Such a behaviour was not observed during tests of a pyrotechnic actuator equipped in a piston with flat surface.

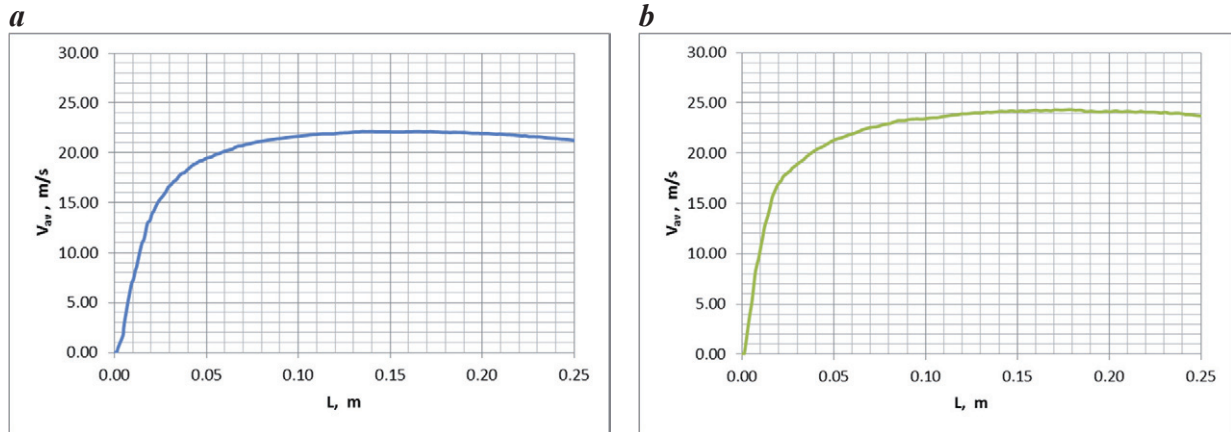

Fig. 4. Piston average velocity; a – flat piston surface, b – concave piston surface

Average acceleration of the piston in two embodiments is shown in Fig. 5. Considering the tests of the actuator equipped with a flat piston surface (Fig. 5 a) it is visible that the acceleration is much lower than in the case of the second piston embodiment (Fig. 5 b). Moreover, the difference of great importance can be observed on those two charts (i.e. Fig. 5). Namely, except for the difference value of the acceleration, there is a difference in the gradient approaching to zero acceleration. In the case of flat piston surface (Fig. 5 a) the line representing the acceleration approaches zero with a slope under some inclination, while the concave piston surface exhibits opposite tendency. Here, (i.e. Fig 5 b) the acceleration maintains on constant, close to maximum for greater piston stroke distance, and then rapidly decreases. Interestingly in both cases, the acceleration assimilates to each other after reaching 2000 m/s^2 and vanishes after approximately this same stroke distance (i.e. in the range of 0.1-0.15 m).

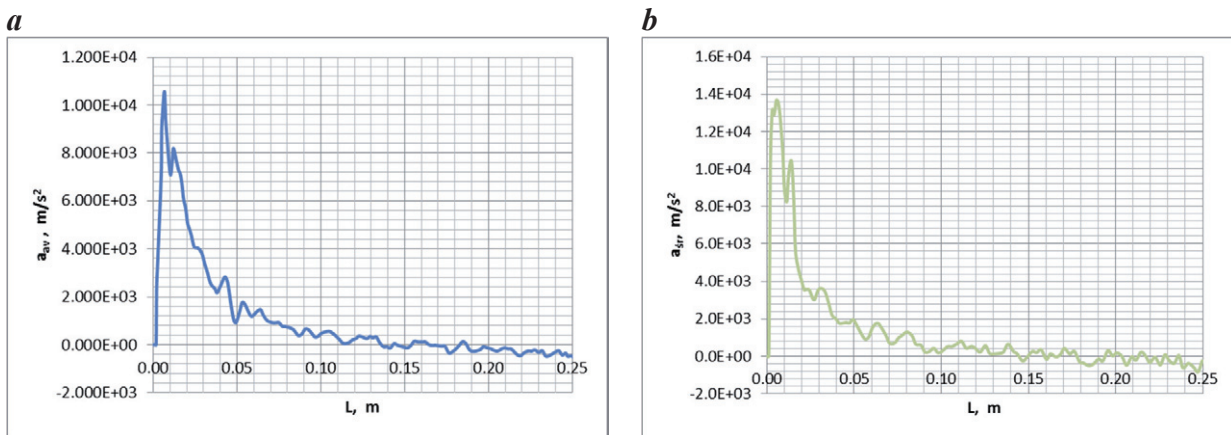

Fig. 5. Piston average acceleration; a– flat piston surface, b – concave piston surface

Dynamic pressures measured by the sensor located above a chamber between the bottom of the cylinder and a piston (see Fig. 3) exhibits significant differences as well. It appears that in case of the flat piston surface (Fig. 5 column a) the dynamic pressure is greater comparing to the test of a concave piston (Fig. 5 column b). The tendency is visible in every repetition of a particular test. This proves reliability of the tests. In every case this same time of a pyrotechnic gas generator was used, hence the overall pressure generated by it is assumed to be constant. However, as it was already mentioned the pressure sensor measures a dynamic pressure, also dependant on the wave velocity. Hence, the difference in pressure indicates anticipated (basing on theoretical knowledge [12], [13]) increase of wave velocity. This in turn, combine with a shock wave focusing phenomenon affect the piston movement characteristics [5], [9]. In case of a confined cylinder with a movable wall a reflected shock from a piston surface propagates backwards becoming an incident shock wave on a cylinder bottom located on the opposite side [4]. The investigation conducted here suggests that this phenomenon is repeated multiple times. Hence, the shock wave reflected from a concave reflector traveling with greater velocity and later being reflected from the cylinder bottom back again impinges a concaves piston with greater energy. This provokes more rapid piston start and velocity.

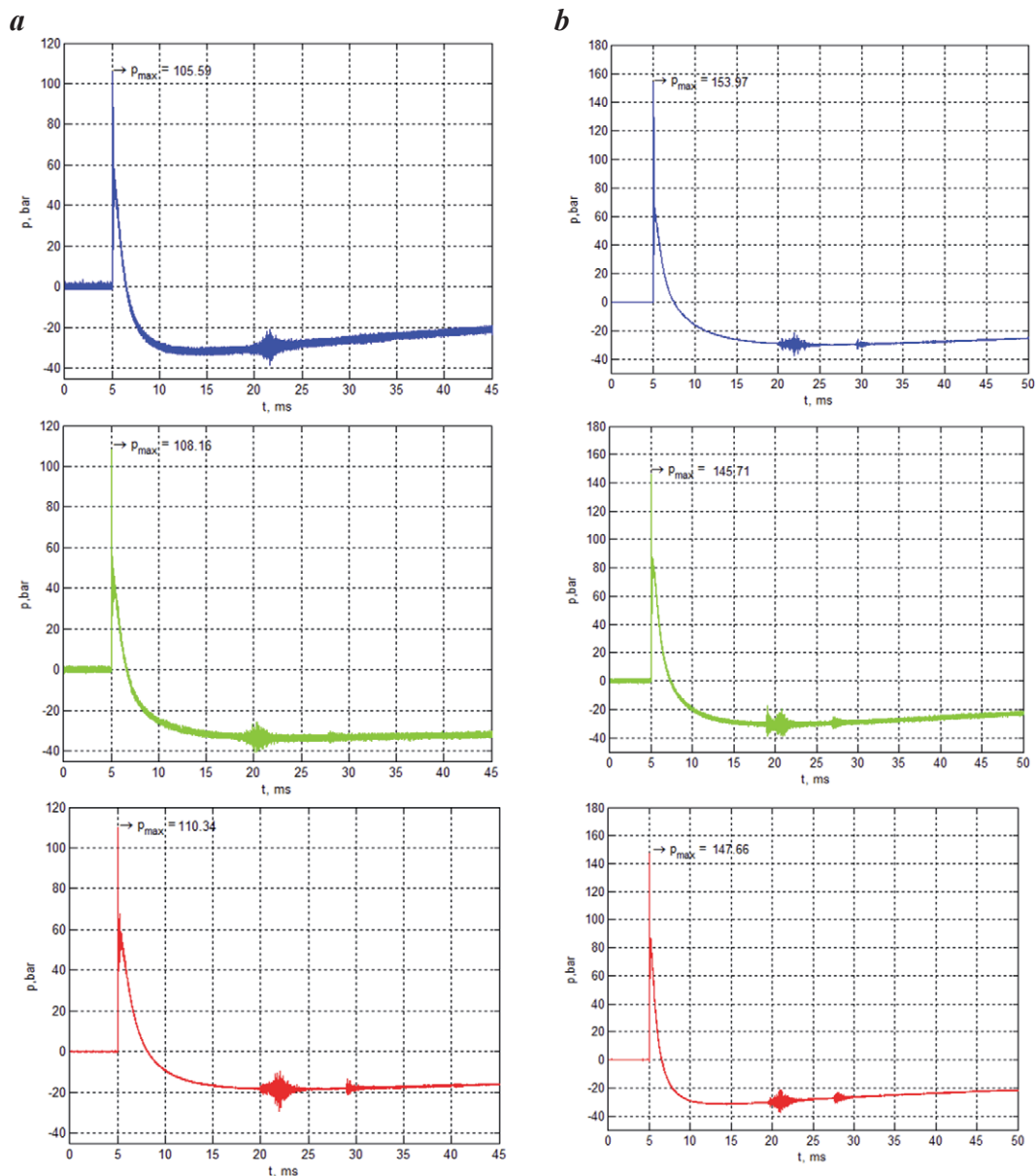

Fig. 6. Dynamic pressure within a pyrotechnic actuator chamber; a – flat piston surface. b – concave piston surface

5. Conclusion

The goal of the deliberation performed here was to investigate the relationship between the geometry of a pyrotechnic actuator and its characteristics (in this case the velocity and acceleration of the piston). It has been experimentally proven that the appropriate shaping of an actuator interior can influence its stroke characteristics. This can lead to cost reduction due to smaller portion of the explosive required for obtaining a defined velocity, or alteration of the piston velocity without changing a pyrotechnic charge. The experiment described here was conducted with only two shapes of the piston surface. However, taking into consideration the significant difference of piston stroke characteristics, further research concerning a global optimization of an actuator interior appears to be justified. The results of three repetition of each test are burthened with relatively small error, which suggest reliabilities of the tests. This was further proven by Cochran's criterion.

References

- [1] Kcrjytoff, V., *Analysis and design of a pyrotechnic powered self-stopping actuator*, January 10, PhD Dissertation University of California/Livermore, 1975.
- [2] Lee, H. S., *Unsteady gas dynamics effects in pyrotechnic actuators*, Journal of spacecraft and Rockets, Vol. 41, No 5, pp. 877-886, 2004.
- [3] Fordham, S., *High explosives and propellants*, Pergamum Press Ltd., second edition, 1980.
- [4] Nabulsi, S. M., Page, N. W., *Response of a movable walls to a shock wave*, 11th Australian Fluid mechanics Conference, University of Tasmania, pp. 35-38, Hobart, Australia 14-18 December 1992.
- [5] Gushanov, A. R., *Dependence of the Shape of a Detonation Wave Front on the Detonation Wave Velocity upon Detonation of a Cylindrical Charge*, Combustion, Explosion, and Shock Waves, Vol. 37, No. 1, pp. 113-118, 2001.
- [6] Górnjak, A., Kaźmierczak, A., Krakowian, K., Włostowski, R., Błasiński, T., *The numerical simulation of the pyrotechnic actuator for the active bumper*, Journal of KONES Powertrain and Transport, Vol. 19, No. 126, 2012.
- [7] Henshaw, W. D., Smyth, N. F., Schwendeman, D. W., *Numerical shock propagation using geometrical shock dynamics*, J. Fluid Mech., Vol. 171, pp. 516-545, 1986.
- [8] Johansson, B., Apazidis, N., Lesser, M. B., *On shock waves in a confined reflector*, Wear 233-235, pp. 79-85, 1999.
- [9] Gui, M., Fan, B., Dong, G., Ye, J., *Interaction of a reflected shock from a concave wall with a flame distorted by an incident shock*, Shock Waves, 18, pp. 487-494, 2009.
- [10] Lee, J. H. S., *The detonation phenomenon*, Cambridge University Press, 2008.
- [11] Kistler Quartz High-Pressure Sensor Type 601A, 601H.
- [12] Ben-Dor, G., *Shock-Wave Reflection Phenomena*, Springer Verlag, New York, N.Y., U.S.A. 1991.
- [13] Vasil'ev, A. A., Vasil'ev, V. A., *Diffraction of waves in combustible mixtures*, Journal of Engineering Physics and Thermophysics, Vol. 83, No. 6, pp. 1178-1196, 2010.

