

**POSTĘPY W INŻYNIERII MECHANICZNEJ
DEVELOPMENTS IN MECHANICAL ENGINEERING**

1(1)/2013, 19-28

Czasopismo naukowo-techniczne Scientific Journal

Kazimierz DZIERŻEK¹

**MODULAR DIGITAL SYSTEM OF CONTROL AND POSITION
MEASUREMENT**

Summary: The article presents a modular digital system of the control and position measurement. It shows the structure of modules with photoelectric and capacitive linear encoders, and a universal solution for the control and position measurement.

Keywords: position measurement, photoelectric linear encoders

1. INTRODUCTION

Continuous and precise position measurement has always posed several problems. At present more and more often electronic measuring devices are used to measure the position. A traditional vernier caliper is often substituted by an electronic caliper, which, in spite of being five times more expensive, is more precise and convenient to use. A traditional micrometer is squeezed out by an electronic micrometer. A number of other electronic devices slowly substitute traditional ones. The development of computer technology and electronics leads to the creation of new devices, for example, a three-point inside micrometer. Electronic linear encoders of different kind and precision (even in one machine tool) squeeze out optical position reading. Because of this there is a necessity to create a new position reading device which could read signals sent by various measuring devices. One of the solutions to this problem is designing a device of the modular structure, which is presented in this article.

2. THE MODULAR STRUCTURE OF THE DIGITAL SYSTEM OF THE POSITION MEASUREMENT

A wide range, precision, and the dynamics of the position measurement impose the construction of modular digital devices. The suggested modular solution for the digital position measurement enables:

- measure the position using the capacitive linear encoders,
- measure the position using the optoelectronic linear encoders,
- measure the position and the angle using rotary encoders,
- control devices characterised by up to 64 digital inputs and up to 64 digital outputs.

¹ *Dr inż. Kazimierz Dzierżek, Białystok Technical University, Faculty of Mech. Eng., Department of Automatics and Robotics, Wiejska 45c, 15 - 351 Białystok; Poland*

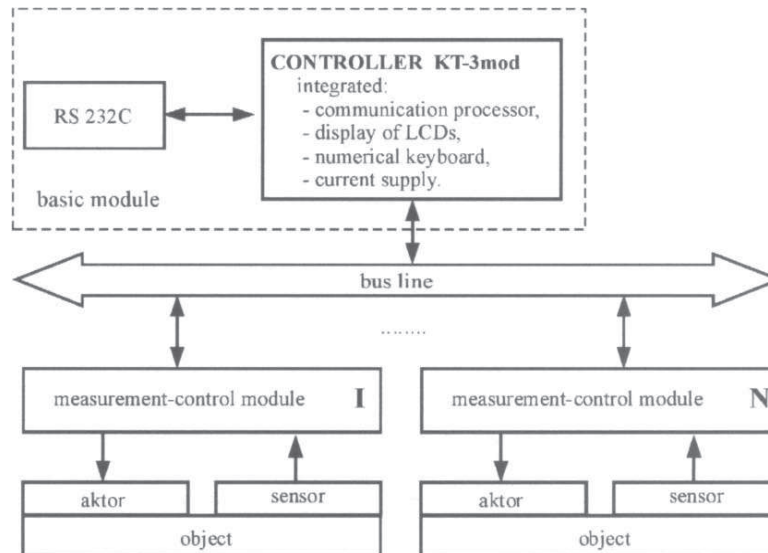

Fig. 1. Block diagram of the digital system of the position measurement
 Rys. 1. Schemat blokowy cyfrowego układu do pomiarów położenia

The block diagram of the digital system of the position measurement divided into modules is shown in Figure 1. The system consists of one basic module and some (if needed) measurement-control modules.

2.1. The structure of the basic module

The basic module consists of:

- a communication processor,
- a display of LEDs,
- a numerical keyboard,
- current supply.

Figure 2 shows an electronic diagram of the basic module. The display is to send information to the operator about the position of the device. It consists of the displays of LEDs because in industrial conditions they are more visible than LCDs. The numerical keyboard is used to type in the information to the measurement-control block via the communication processor. The information, shown as a series of numbers, appears on the display. The keyboard consists of 19-25 keys and a decoder. The decoder sends, via a series transmission, the digital information to the communication processor.

Modular digital system of control and position measurement

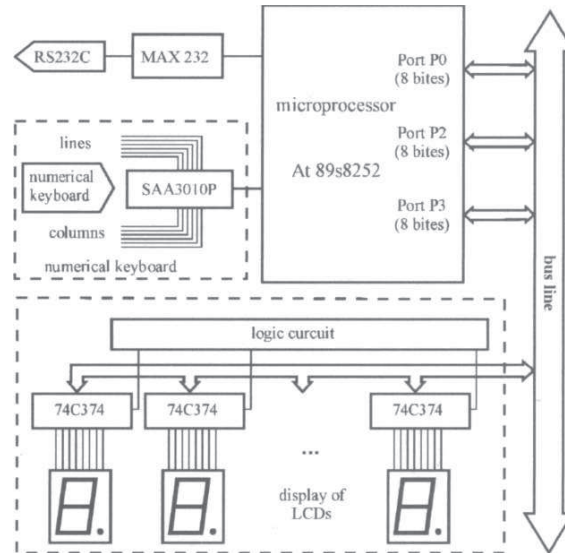

Fig. 2. Simplified electronic diagram of basic module
Rys. 2. Uproszczony schemat elektroniczny modulu podstawowego

2.2. The structure of the measurement module with capacitive linear encoders

A simplified electronic diagram of the measurement-control module equipped with an "opto" cable and capacitive linear encoders of the "popular" type is presented in Figure 3.

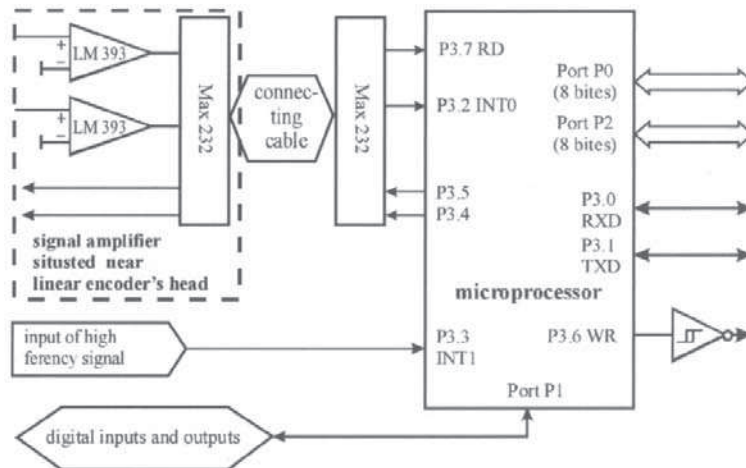

Fig. 3. Simplified electronic diagram of measurement-control module with attached capacitive linear encoder

Rys. 3. Uproszczony schemat elektroniczny modulu pomiarowo-kontrolnego z liniowym enkoderem pojemnościowym

Processor AT 89c51 used in this module performs the following functions:

- it puts the linear encoder into a fast mode (45 transmissions per second),
- it receives the message from the linear encoder about the device's position,
- it converts the information into a decimal system,
- it sends the information to the display,
- it receives and exercises commands from the numerical keyboard,
- it compares the current position of the device with the set position,
- it sends the commands to the executive block (it controls the engine's operation),
- it controls the operation of the linear encoders.

2.3. The structure of the measurement module with optoelectronic linear encoders

Figure 4 shows a simplified electronic diagram of the measurement-control module with the attached optoelectronic linear encoders.

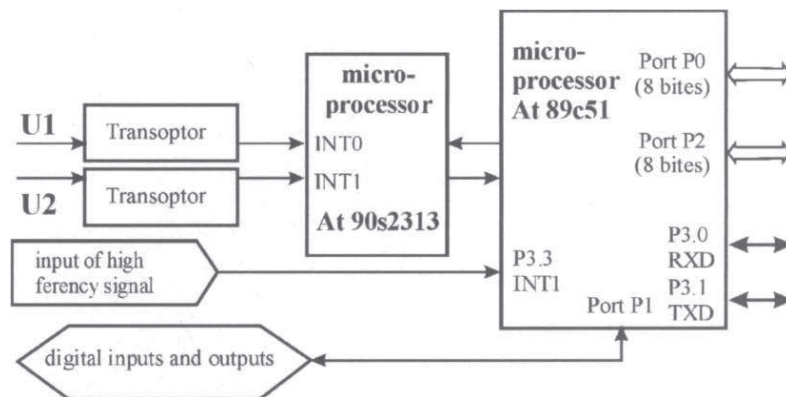

Fig. 4. Simplified electronic diagram of measurement-control module with attached optoelectronic linear encoder

Rys. 4. Uproszczony schemat elektroniczny modułu pomiarowo-kontrolnego z liniowym enkoderem optoelektronicznym

In the measurement-control module two processors are used. Processor AT 90s2313 performs the following tasks:

- it receives U1 and U2 measuring signals indicating the device's position from the linear encoder,
- it sends the information about the device's position to the second processor,
- it controls the operation of the measuring linear encoder.

Processor AT 89c51 performs the following tasks:

- it receives the information from the linear encoder about the position of the first processor's device,
- it converts the information into a digital system,
- it receives and exercises the commands from the numerical keyboard,
- it compares the current position of the device with the position that is to be taken,
- it sends the commands to the executive block (it controls the engine's operation),
- it controls the operation of the first processor.

Microprocessor 90s2313 is only supposed to count U1 and U2 impulses going from the measuring linear encoder. The processor functions like a down-up counter. The counted value is sent at certain intervals of time to the second processor. Processor 89c51 counts the received value, converts it into a decimal system and then, sends it to the display.

2.4. The structure of the measurement module with rotary encoders

The measurement-control module co-operating with the rotary encoders is almost identical to the module shown in Figure 5. The only difference is the processor's software. In processor 89c51 the values received from the first processor are counted and displayed as the angle's value or, after being multiplied by the lead of the screw thread, as the linear position value.

2.5. The structure of the control module with digital input and output

Figure 5 presents the simplified electronic diagram of the digital input and output module. The module consists of 64 digital inputs and 64 digital outputs, and, additionally, two inputs of high frequency signals, two counter inputs and eight direct inputs-outputs.

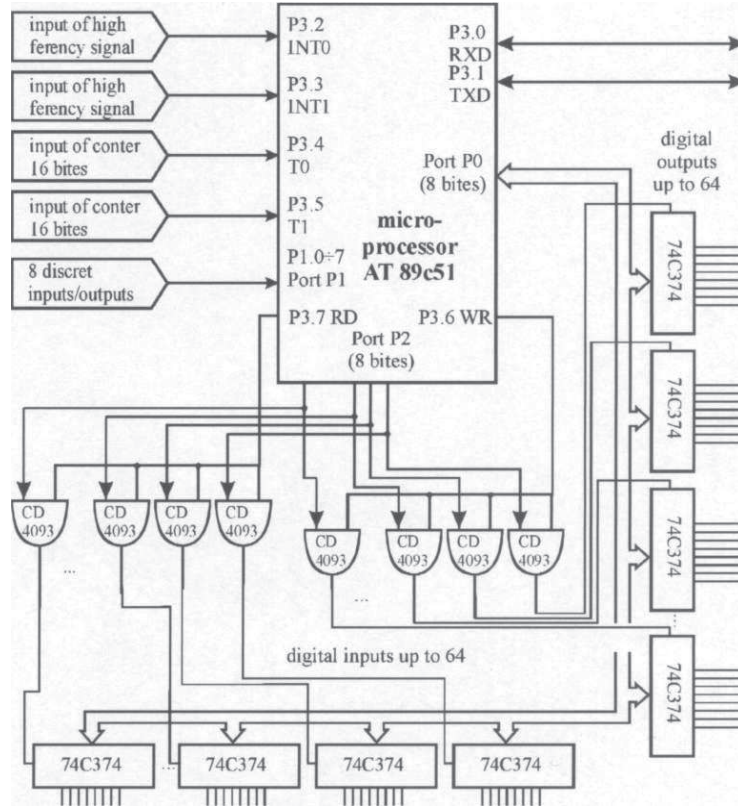

Fig. 5. Simplified electronic diagram of digital input and output module

Rys. 5. Uproszczony schemat elektroniczny modulu z cyfrowym wejściem i wyjściem

3. PARAMETERS OF THE DIGITAL SYSTEM OF THE POSITION MEASUREMENT

The digital system of the position measurement can consist of up to six modules, and there can be only four measurement-control modules among them. The measuring range of the controller is restricted to the digits on the display and ranges from -1999.999 mm to 9999.999 mm. Figure 6 shows an exemplary triaxial digital system of the position measurement.

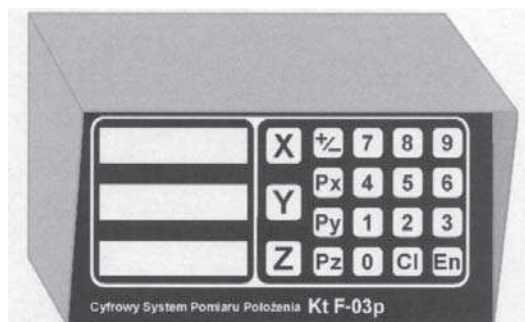

Fig. 6. Tri-axial digital system of position measurements
Rys. 6. Trzyosiowy cyfrowy układ do pomiarów położenia

The keys below perform the following functions:

- X , Y , Z (ZI) – they reset and pre-set the measurement, +/- – it indicates the sign change,
- Px , Py , Pz – they change the counting direction, Cl – it cleans the typed-in measurement,
- En – it confirms the measurement, 0-9 – they are used as numerical keys.

CONCLUSION

Digital systems of the position measurement are usually used in the modernisation of mechanical machine tools. The application of this system increases the precision of the details and shortens the time of the detail construction even by 30%. The expenses of the machine tool modernisation pay off within a year.

REFERENCES

- [1] DZIERŻEK K.: Increasing the accuracy of the digital system of the position measurement through extrapolation. 5th International Carpathian Control Conference. Vol.1, Zakopane, May 25-28, 2004. Polish Academy of Science, Kraków 2004.
- [2] SIEMIENIAKO F., DZIERŻEK K., SZCZEBIOT R., GAWRYSIAK M.: Wybrane mechatroniczne układy pomiarowe i wykonawcze. Rozprawy Naukowe Politechniki Białostockiej nr 61. Białystok 1999.
- [3] STARECKI T.: Mikrokontrolery jednocukładowe rodziny 51, Nozomi, Warszawa 1996.
- [4] Atmel Corporation, Mikrocontroller Data Book, October 2002.
- [5] Karty katalogowe firmy KATECH.

MODUŁOWY CYFROWY UKŁAD STEROWANIA I POMIARU POŁOŻENIA

Streszczenie: W artykule przedstawiono modułowy cyfrowy system sterowania i pomiaru położenia. Przedstawiono struktury modułów z fotoelektrycznym i pojemnościowym liniowym enkoderem, a także uniwersalne rozwiązanie sterowania i pomiaru położenia.

Słowa kluczowe: pomiar położenia, fotoelektryczny enkoder liniowy