

EXPERIENCE IN RENEWAL BWEs BUCKET AT MÁTRAJ ERŐMŰ SA OPEN PIT

RENOWACJA CZERPAKÓW WIELONACZYNIOWYCH KOPAREK KOŁOWYCH W KOPALNI MÁTRAJ ERŐMŰ SA

Ladányi Gábor, Zoltán Virág - University of Miskolc, Department of Geotechnical Equipment, Hungary

The Department of Geotechnical Equipment is involved since two decades in research and development of teeth, buckets and other active parts of different kinds of mining excavators. The actual study is devoted to reveal new difficulties arising when excavating in the sandstone as overburden rock, mainly regarding the buckets of bucket wheel excavators. As a consequence of the increased cutting forces, the buckets suffer deformations. In case of the change of cutting geometry, as a result of renewal (strengthening) of buckets, the winning becomes no-optimal and there will be more breakdowns. The investigations made and reported in the actual paper led to provide guidelines for a better renewal method of buckets.

Keywords: bucket wheel excavator, bucket, examination, deformation, patterns

Department of Geotechnical Equipment od dwóch dekad zajmuje się badaniami i rozwojem zębów, czerpaków oraz innych aktywnych elementów różnych maszyn podstawowych. Aktualne badania służą rozwiązaniu problemów związanych z pracą koparek wielonaczyniowych kołowych w nadkładzie zawierającym piaskowce. W wyniku pracy w takim środowisku, a co za tym idzie, zwiększonych sił skrawania, czerpaki koparek ulegają odkształceniom. Zmiana geometrii procesu cięcia skały, która jest rezultatem renowacji czerpaków prowadzi do nieoptymalnego urabiania skutkującej zwiększoną ilością awarii. Przeprowadzone badania, przedstawione w niniejszym artykule, doprowadziły do opracowania wytycznych nowej, lepszej metody renowacji czerpaków.

Słowa kluczowe: koparka wielonaczyniowa, wysięgnik, wibracje, przyśpieszeniometer, tensometr

FOREWORD

At the Mátraerő Erőmű Zrt. open pit lignite mine, the overburden removal is made using bucket wheel excavators (Fig. 1). The efficient excavation imposes difficult tasks, among other elements of excavating system, on the buckets, which during operation are the first to be in contact with the rock to be excavated. Their main tasks are to loosening the rock from overburden and transform it in proper state to be conveyed.

In order to reduce the specific energy consumption at the

lowest possible level, which implies also reduction of excavating costs, it is absolutely necessary to maintain the operating condition of the bucket at maximal possible efficiency. That means also, that the time between two renewals must be as long as possible. One of ways to realize this outcome if the shape, construction of the bucket is compliant, optimally adapted to the excavator's operating technology. In this respect, the specialists from Mátraerő Erőmű Zrt. have designed and developed new buckets in the past years (Fig. 2), [1], which improvement



Fig. 1. SRs2000 Bucket Wheel Excavator
Rys. 1. Koparka SRs 2000

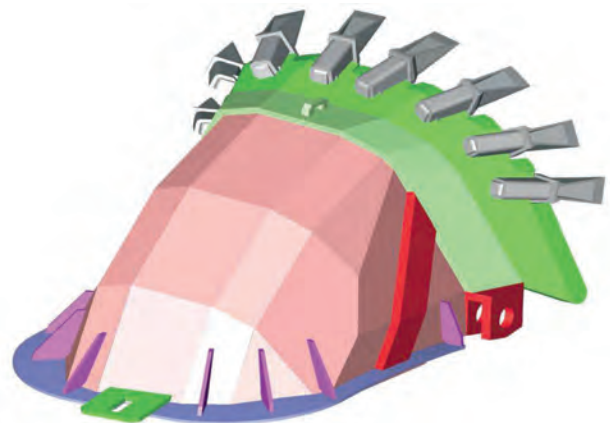

Fig. 2. 3D model of the new bucket
Rys. 2. Trójwymiarowy model nowego czerpaka

necessity has been observed also in other countries [2].

The operating experience with these new buckets was favourable. That means that in constant productivity, the energy consumption has been reduced and the amount of excavated rock until allowable wear of teeth has increased. But, the same buckets after renewal has not exposed such favourable parameters as it has been experienced with new ones. The operating responsible specialists were confronted with the question: what is the difference between the state of renewed and the new buckets? In order to find out an answer to this question, the staff of the Department of Geotechnical Equipment from Miskolc University has performed a series of examination measurements on a set of renewed buckets.



Fig. 3. The deficiency of the relative position of the tooth on cutting blade at the renewed buckets

Rys. 3. Błędna pozycja zęba na ostrzu tnącym po renowacji czerpaka

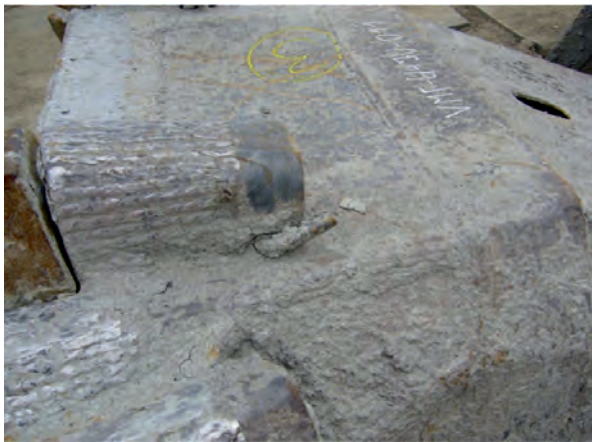

Fig. 4. Wrong positioning of the tooth adapters on the renewed buckets

Rys. 4. Złe ustawienie opraw zębów na czerpakach po renowacji



Fig. 6. Renewed cutting blade with adapters

Rys. 6. Odnowione ostrze tnące z oprawami

The task has two components:

The comparison between the state of new and renewed buckets, based on measurements, indicating the observed differences causes.

Design of a manufacturing supporting pattern for the renewal process. The result of using such a pattern is the reduction of angle errors when mounting the teeth.

The actual paper deals only with the results obtained relative to the first point of the task.

THE AFTER OPERATION STATE OF THE BUCKETS

Before the measurements we made visual observations regarding the renewed buckets, which led to the following observations:

A general deficiency, – present at ~95% of teeth – the tooth is located in the teeth support (adapter) in such a manner that it is not fitted on the cutting blade of the bucket (Fig. 3).

The main load carrying element of the bucket is the cutting blade together with the tooth support. Since analysing the case of opened cutting buckets, it is obvious that even this kind of bucket is capable to support the nominal loads. For this reason during the design process, we considered as a preliminary condition that a part of the cutting forces acting on the tooth to be transferred to the cutting blade. If this condition is not fulfilled, i.e. the tooth is not supported by the cutting blade, the tooth adapter, by its welded joint to the blade is enforced to transfer all the forces acting on the tooth towards the cutting blade.



Fig. 7. Failure of teeth

Rys. 7. Uszkodzenie zębów

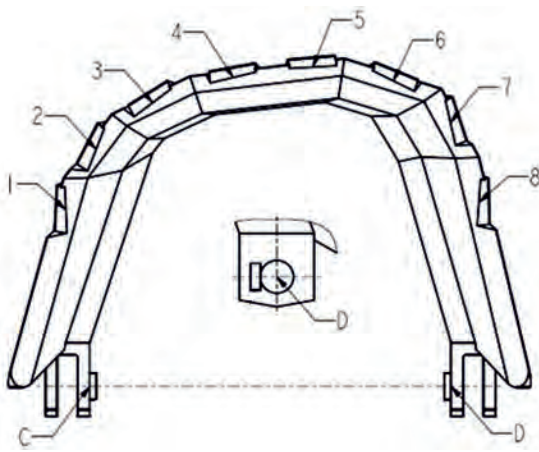

Fig. 8. Measure points of blade geometry verification
Rys. 8. Punkty pomiarowe geometrii ostrza

The welded joint is only partially capable of doing this. It is dimensioned in such a manner, that if the forces acting on the tooth exceed the nominal value, it is better to fail the welded joint and in this manner protecting from the damage of the bucket. Or, in the working environment in which the analysed BWE and buckets operate, due to the hard sandstone inclusions, it is very frequent the case in which the cutting forces exceed more times the nominal value.

Previously performed tests in order to find out the values of cutting forces, on samples collected at Visonta and Bükkábrány mines, [3] indicated that the ratio of cutting forces in clay to cutting forces in sandstone is about 1:14, which means that peak forces may increase with more than 1 order of magnitude.

The tooth adapters are not well positioned (located) in many cases. The incorrect setting of tooth adapters in the positions near to the connecting edges of the cutting blade can be observed even visually without any measuring device. In the figures 4-5 we can easily observe the wrong distance between two adapters located in the vicinity of the connecting edge between front plate and lateral plate of cutting blade.

The intervals between adapters of the cutting blade, during renewal are burdened with weld, so they lose the “cutting edge” character, as it can be seen in figure 6. It is recommended that, during renewal to maintain the initially – prescribed in the design- chamfered edge.

Also we have had suspicions about the constant character of the teeth’s material. The experience revealed that after different

renewal cycles, teeth made from different quality of material were mounted on buckets. The figure 7 illustrates the evidence of such a situation. We can see on the same bucket bent teeth together with broken ones. That indicates that the quality of teeth’s material varies in a very large range.

EXAMINATION MEASUREMENTS

In most of cases the deformations of the blade, which affect the overall structure of the bucket’s body, can be observed visually, without measurement. If we look to the bucket from teeth side, we can observe that the polygonal shape of the blade is modified in respect with the designed one. This fact is obviously demonstrated by the results of our measurements.

In this respect, the examination measurements were focused on the verification of the bucket’s and connected parts. This task has been performed by measuring the diagonal point to point distances between the numbered points as in figure 8 (from point C to 2...8 and from point D to 7...1). Accordingly, we measured for each bucket 14 distances, which is an overall amount of 238 measurements on 17 buckets, which is enough to have a statistical population. The measured distances selected for verification of the shape (geometry) modifications are connected to the cutting blade, because it is the main load carrying element of the bucket. Any distortion on its shape is responsible for any modification on excavation capability of the bucket.

In selecting measurement points and distances we considered those which are accessible and usable even in case of worn buckets. That is the reason for which we selected the points as in figure 8, and the diagonal distances between each bucket connecting pin centre (C and D) and the centre points of teeth lips supporting cavities on the blade. For reasons of comparison possibility, we calculated the relative deviation of each measured value related to the average. The corresponding data were drawn out for each bucket, as an example the diagram for the bucket no. 14 is presented in figure 9.

As it can be seen, the average value of the relative deformations (red line with value above) is not very high, being under 2%. But if we analyse individual values, we find greater deviations, as the D3 value on figure 9 is 92.8% of the average value, so the deviation is 7.2%, the highest among 14 records of 17 buckets.

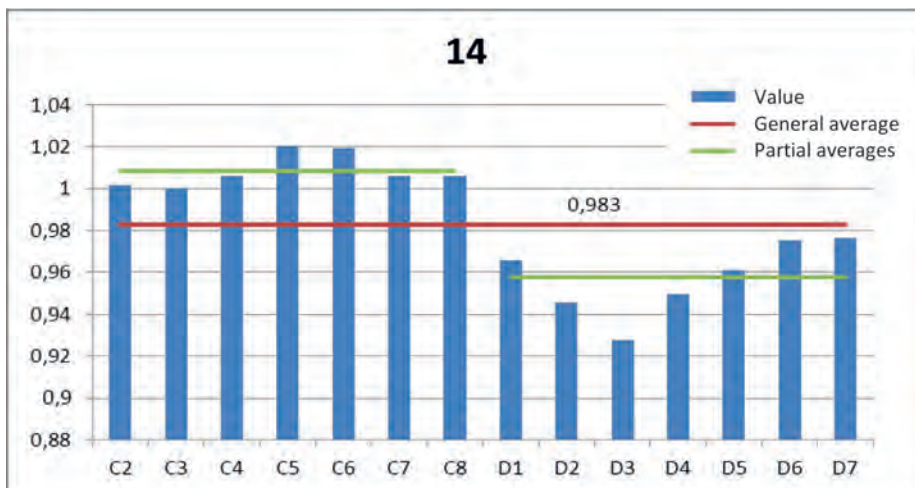

Fig. 9. Relative deviations diagram for the bucket no. 14
Rys. 9. Wykres względnych odchyień dla czerpaka nr 14

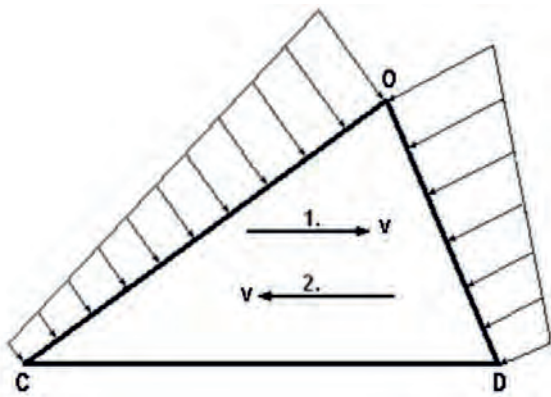

Fig. 10. Simplified triangular shape model of the bucket
Rys. 10. Uproszczony, trójkątny model czerpaka

The extent of the present paper does not allow to present the diagrams of each of 17 bucket, but analysing them together it is evident that distances from C are above the average, and those from D are located below the average, which is better illustrated by the location of corresponding partial averages marked on diagrams with green lines above each group of measured distances. 71% of buckets were deformed in such of manner that C values increased while D values decreased. By our opinion, this is due to the general overload during excavation and the intrinsic characteristic of asymmetrical shape of the bucket.

In the figure 10, we modelled the bucket with a triangular shape frame, taking into account the load carrying aspect. The

asymmetric character has been represented by the non-equilateral shape of the triangle. The figure illustrates that in case of slewing direction marked with 2 the structure exposes a lower rigidity than in case of opposed slewing direction, marked with 1. In this last case, it can be seen that the CO element is able to support the resultant forces acting on DO element. In the opposite case the DO capability to balance the forces acting on CO segment is lower than previous. So, in case of overload, the structure is more exposed to be deformed in case of 2 slewing direction.

This assumption is confirmed by the fact that in reality the DO segment is more frequently damaged (bending, failure, rupture). When slewing in direction 2, the bucket avoid the increased load, by deformation, the rigid support in case of slewing in direction 1 the DO side is more exposed to failure.

CONCLUSION

The performed measurements and analyses have demonstrated clearly that the renewed buckets which are currently used have a different geometry relative to the initial one, obtained by manufacturing. The first cause of this is the increased cutting resistance of sandstone containing rock. As result, the buckets suffer such a deformation, which the remediation requires an improved procedure, being necessary the use of a pattern in the renewal process.

Literature

- [1] Ladányi G., Sümegi I., Virág Z.: *Meríték- és bontófogfejlesztések első fázisának eredményei a Mátrai Erőmű ZRt. bányáiban üzemelő merítéklétrás kotróknál*, 43. Bányagépészeti és Bányavillamossági Konferencia kiadványa, 135-148. o., Balatonyörök, 2010. szeptember 30-október 1
- [2] Kovács J., András J., Nan M. S., Tomus O. B., András E.: *Elméleti, laboratóriumi és üzemi kutatások eredményei a délromániai lignit gépesített jövesztése esetében*, XVIII. Bányászati, Kohászati és Földtani Konferencia kiadványa, 67-71. o., ISSN 1842-9440, Brassó, Románia, 2016. április 7-10
- [3] Ladányi G., Sümegi I., Virág Z.: *Laboratóriumi kőzetforgácsolási vizsgálatok a Visontai Déli bányatüzemből származó kőzetmintákon*, XXXIX. Bányagépészeti és Bányavillamossági Konferencia kiadványa, 137-149. o., Balatonyörök, 2006. september 28-29



Architectural details of Wrocław

foto. RS-K