

The effect of additional foil wraps on the tightness of the packaging of bales

Andrzej A. Stepniewski, Janusz Nowak

Faculty of Production Engineering, University of Life Sciences in Lublin, Poland
e-mail: andrzej.stepniewski@up.lublin.pl; janusz.nowak@up.lublin.pl

Received: January 23, 2018; Accepted: February 09, 2018

Abstract. The work analyzed the effect of additional wraps on the number of layers and thus the tightness of the material under protection. It was assumed that all the overlaps of each two consecutive wraps are the same, and each additional wrap causes the same increase of all the tabs. The mechanical properties of the film and its dimensions were taken into account. We have written our own simulation program that allows us to calculate the percentage of a given number of film layers on the side of the bale and the visualization of the distribution of layers in its cross-section. Calculation examples have been provided. Conclusions and suggestions resulting from the obtained simulation results have been formulated.

Key words: baled silage, cylindrical bale, stretch film, tightness, mathematical model, simulation model.

INTRODUCTION

Protection of the rolled material for silage consists in mechanical wrapping of singles bales with a flexible film. The wrapping machine should provide a wrapping that meets the requirements of the tightness with the assumed number of layers of film on the entire outer surface, with the lowest possible use of the film.

For wrapping, we use films with the thickness of approx. 25 μm and the width of 0.5 m or 0.75 m and the stretch ratio in the range of 50% to 70%. The following layers are overlapped with the 50% or 75% overlap of the film width [10, 18]. The use of 6 layers to a greater extent ensures the required tightness of the protection [13, 16, 17], however, four layers of the film are usually sufficient [14, 15]. Four layers are obtained when the bale during the wrapping makes 1 turn against its own axis using a 50% overlap or 0.5 turn using the 75% overlap. Impact on the tightness has the degree of the stretch of the film, which has its limitations due to the possibility of microcracks [4, 5, 11, 19]. Despite the tight protection and a high degree of compaction [7], the validity of the silage is determined by the storage time [8].

Due to the fact that the quotient of the length of the wrapped bale circumference and the width of the film reduced by the length of the overlap is rarely an integer, one additional wrapping is applied, which increases the length of the last overlap above the assumed values.

The diameters of the bale as well as the width of the film have dimensions that are within a certain tolerance and, therefore, the number of layers may be smaller than the assumed one [1, 2]. Assuming the cover of the bale with four layers and a 50% overlap, narrow belts can be formed along three layers and, in an unfavorable case, along two layers. Similarly, when using a 75% overlap, three-layer belts can be created, as shown in Fig. 1.

To prevent this, you can apply an even increase of all the overlaps by separating the excess created by the additional wrap. The improvement of tightness depending on the increased width of mutual overlapping of adjacent belts is confirmed by experimental tests [3, 6, 22]. Even distribution of layers also has an impact on reducing film consumption, which is confirmed by the results of a few theoretical and experimental studies [9, 12, 20, 21, 23].

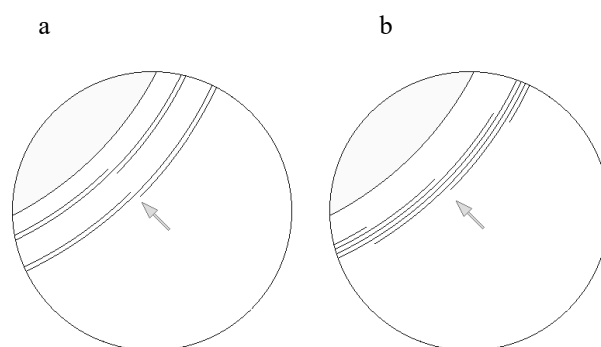

Fig. 1. The unfavorable arrangement of the film layers; a – overlap 50%, b – overlap 75%

In this paper, a wrapping was proposed, in which a small reduction in the width of the film would not reduce the number of layers and thus the deterioration of the tightness. For this purpose, mathematical relations were derived, on the basis of which the authors' own simulation program was developed to determine the

percentage share of the number of layers on the perimeter of the bale with even distribution of all layers. The program makes it possible to visualize the distribution of layers in the cross-section of the bale. The effect of increasing the additional wrappings on the percentage of the number of layers on the circumference that has a direct impact on the tightness of the wrapping was determined. Variations in the length and width of the film after stretching have been taken into account. The influence of the inclination of the film strips on the forming and the influence of deformation of the bale caused by the pressure of the film was not taken into account.

THEORETICAL MODEL

The width of the film after stretching b_{fr} is determined by the relationship [21]:

$$b_{fr} = b_f(1 - \nu_f \varepsilon_{lf}), \quad (1)$$

where:

b_f – width of non-stretched film,

ε_{lf} – deformation of the film (quotient of elongation and initial length),

ν_f – Poisson's coefficient of the film.

The number of wrappings i_o (the rotation of the arm with a roll of film or table with a bale in an axis perpendicular to the axis of the bale) is determined by the dependence [21]:

$$i_o = \frac{\pi D_b n_b}{b_{fr}(1 - k_f)}, \quad (2)$$

where:

D_b – bale diameter,

k_f – dimensionless relative coefficient determining the dimension of the overlap (width of contact of adjacent film strips), $0 < k_f < 1$ (at 50% overlap, $k_f = 0.5$ and $k_f = 0.75$ at 75% overlap),

n_b – number of turns of the bale with respect to its axis, on which the number of layers is dependent (when wrapped with 4 layers $n_b = 1$ rotation at the 50% overlap and $n_b = 0.5$ rotation at the 75% overlap).

Calculated number of wraps i_o is very rarely an integer, so the last overlap z_o will be usually less than the required specified $k_f b_{fr}$:

$$z_o = b_{fr} \left[(1 - k_f)(i_o - [i_o]) + k_f \right], \quad (3)$$

where $[i_o]$ – the largest integer not greater than i_o .

Then, the number of wrappings i_{oc} has to be increased:

$$i_{oc} = [i_o] + i_{od}, \quad (4)$$

where i_{od} – number of additional wrappings (with classic wrapping $i_{od} = 1$).

After the correction, the actual value of the last overlap is calculated z_{or} :

$$z_{or} = b_{fr} - \pi D_b n_b + [(i_{oc} - 1)(b_{fr} - z)], \quad (5)$$

which now will always be greater than the required $k_f b_{fr}$.

Assuming that all the overlaps are to be the same, their values are increased from the excess obtained and their value is determined by the dependence:

$$z = \frac{z_{or} - k_f b_{fr}}{i_{oc}} + k_f b_{fr}, \quad (6)$$

so the new value of the coefficient k_f :

$$k_f = \frac{z}{b_{fr}}. \quad (7)$$

The new value of the coefficient k_f will always be higher than the one assumed at the beginning and its value will increase as the i_{oc} increases.

The surface of the used film for the wrapper is determined by the relationship:

$$S_f = \frac{2i_{oc} b_f (D_b + H_b)}{\varepsilon_{lf} + 1}, \quad (8)$$

where: H_b – height (width) of the bale.

To investigate the geometry of the layers on the wrapped bale and to calculate the percentage of number of layers on the perimeter of the bale, a procedure was developed in which the following values are calculated:

The arc measure of the α_f angle based on an arc equal to the width of the stretched film:

$$\alpha_f = \frac{2b_{fr}}{D_b}. \quad (9)$$

The arc measure of the angle α_z based on an arc equal to the width of the overlap:

$$\alpha_z = \frac{2k_f b_{fr}}{D_b}. \quad (10)$$

Angular beginning $\alpha_{p1,i}$ and end $\alpha_{k1,i}$ of the i arc equal in length to the stretched film:

$$\alpha_{p1,i} = (i-1)(\alpha_f - \alpha_z), \quad (11)$$

$$\alpha_{k1,i} = i(\alpha_f - \alpha_z) + \alpha_z, \quad (12)$$

Angular beginning $\alpha_{p2,i}$ and end $\alpha_{k2,i}$ of the i arc equal in length to the stretched film on the opposite side:

$$\alpha_{p2,i} = (i-1)(\alpha_f - \alpha_z) + \pi, \quad (13)$$

$$\alpha_{k2,i} = i(\alpha_f - \alpha_z) + \alpha_z + \pi, \quad i = 1 \dots i_{oc}. \quad (14)$$

If the value of 2π of the calculated angles is exceeded according to the relationship (11) - (14), the value of 2π is subtracted. The calculated values according to the dependence (9) - (14) are marked in Fig. 2, which shows the variant of the wrapping: $b_f = 0.75$ m, $n_b = 0.5$, $i_{oc} = 16$, $i_d = 3$, $k_f > 0.5$.

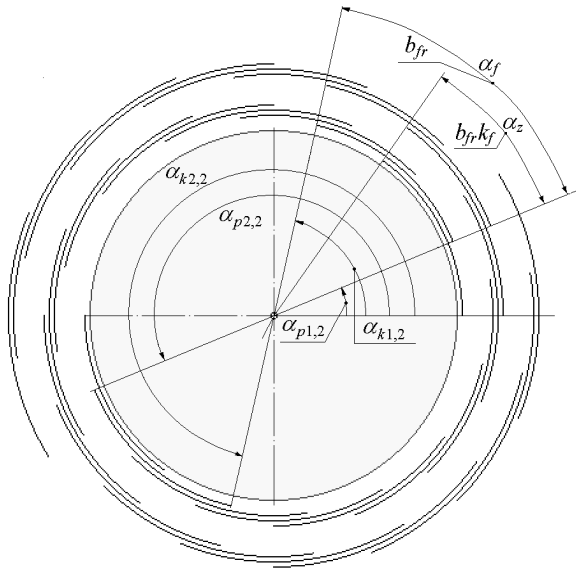

Fig. 2. Geometry of the distribution of film strips in the cross-section with an even distribution of the overlaps

In the interval $(0, 2\pi)$ angular ranges $\alpha_{n,k}$ are computed with the same number of n layers according to the formula:

$$\alpha_{n,k} = \sum_{i=1}^{i=i_{oc}} [(\alpha_{p1,i} - \alpha_{k1,i}) + (\alpha_{p2,i} - \alpha_{k2,i})], \quad (15)$$

where: $\alpha_{n,k}$ is the angle range on which n layers are counted, k is the next number of the angle range with the same number of layers.

Angular ranges in which n layers are located are the sum of angular ranges with the same number of layers:

$$\alpha_n = \sum_{k=1}^{k=k_{max}} \alpha_{n,k} \quad n = n_{min} \dots n_{max}. \quad (16)$$

The percentage of P_n of the specified number n of layers on the circumference of the bale is calculated as:

$$P_n = \frac{\alpha_n}{\pi} 50\%. \quad (17)$$

NUMERICAL EXAMPLES

Typical bale dimensions were adopted, diameter $D_b = 1.2$ m, bale height $H_b = 1.2$ m and it was assumed that the bale was to be secured with at least four film layers. Poisson's coefficient of the film was assumed as $\nu_f = 0.34$, unit elongation $\epsilon_{if} = 0.7$. It was assumed that all overlaps are the same and each additional wrap increases all overlaps.

In order to investigate the effect of additional wrapper on the number of layers, calculations were made for two widths of film b_f , for which two values of overlaps were used:

$k_f \geq 0.5$ and $k_f \geq 0.75$. Variants of wrappings are marked with the letters A1, A2, B1, B2, for which the following values have been adopted:

- A1: $b_f = 0.5$ m, $n_b = 1$ rotation, $k_f \geq 0.5$,
- A2: $b_f = 0.5$ m, $n_b = 0.5$ rotation, $k_f \geq 0.75$,
- B1: $b_f = 0.75$ m, $n_b = 1$ rotation, $k_f \geq 0.5$,
- B2: $b_f = 0.75$ m, $n_b = 0.5$ rotation, $k_f \geq 0.75$.

For such values, according to the dependences (1) and (2), for variants A1 and A2, $b_{fr} = 0.38$ m, $i_o = 19.84$ and for variants B1 and B2 $b_{fr} = 0.57$ m, $i_o = 13.23$. Other sizes are given in Table 1.

Table 1. Numerical values of calculated quantities for two typical film widths and two methods of wrapping with increasing number of wrappings

Factor	Unit	Numerical value A1 $k_f > 0.50$ ($b_{fr} = 0.38$ m, $i_o = 19.84$)										
i_{oc}/i_{od}		20/1	21/2	22/3	23/4	24/5	25/6	26/7	27/8	28/9	29/10	30/11
z	cm	19.15	20.05	20.86	21.61	22.29	22.92	23.50	24.04	24.54	25.00	25.44
k_f		0.504	0.528	0.549	0.569	0.587	0.603	0.618	0.633	0.646	0.658	0.669
S_f	m ²	28.24	29.65	31.06	32.47	33.88	35.29	36.71	38.12	39.53	40.94	42.35
P_4	%	98.39	76.61	78.22	36.30	58.04	0	37.90	0	17.75	0	0
P_5	%	0	23.36	0	63.66	0	95.98	0	55.64	0	15.34	0
P_6	%	1.61	0	21.76	0	41.91	4.01	62.05	44.31	82.22	84.64	97.59
P_7	%	0	0	0	0	0	0	0	0	0	0	0
P_8	%	0	0	0	0	0	0	0	0	0	0	2.40

Factor	Unit	Numerical value A2 $k_f > 0.75$ ($b_{fr} = 0.38$ m, $i_o = 19.84$)										
i_{oc}/i_{od}		20/1	21/2	22/3	23/4	24/5	25/6	26/7	27/8	28/9	29/10	30/11
z	cm	28.58	29.03	29.43	29.81	30.15	30.46	30.75	31.02	31.27	31.50	31.72
k_f		0.752	0.764	0.775	0.784	0.793	0.802	0.809	0.816	0.823	0.829	0.835
S_f	m ²	28.24	29.65	31.06	32.47	33.88	35.29	36.71	38.12	39.53	40.94	42.35
P_4	%	96.79	76.61	56.44	36.30	16.15	0	0	0	0	0	0
P_5	%	3.21	23.36	43.52	63.66	83.83	95.98	75.80	55.64	35.50	15.34	0
P_6	%	0	0	0	0	0	4.01	24.17	44.31	64.45	84.64	95.19
P_7	%	0	0	0	0	0	0	0	0	0	0	4.81
P_8	%	0	0	0	0	0	0	0	0	0	0	0

Factor	Unit	Numerical value B1 $k_f > 0.50$ ($b_{fr} = 0.57$ m, $i_o = 13.23$)										
i_{oc}/i_{od}		14/1	15/2	16/3	17/4	18/5	19/6	20/7	21/8	22/9	23/10	24/11
z	cm	30.07	31.87	33.44	34.83	36.06	37.16	38.15	39.05	39.87	40.61	41.30
k_f		0.528	0.559	0.587	0.611	0.633	0.652	0.669	0.685	0.699	0.712	0.724
S_f	m ²	29.65	31.76	33.88	36.00	38.12	40.24	42.35	44.47	46.59	48.71	50.82
P_4	%	88.30	46.37	58.04	0	27.82	0	0	0	0	0	0
P_5	%	0	53.58	0	85.89	0	25.42	0	0	0	0	0
P_6	%	11.69	0	41.91	14.09	72.14	74.55	97.59	64.89	67.31	4.45	37.10
P_7	%	0	0	0	0	0	0	0	35.06	0	95.54	0
P_8	%	0	0	0	0	0	0	2.41	0	32.65	0	62.85

Factor	Unit	Numerical value B2 $k_f > 0.75$ ($b_{fr} = 0.57$ m, $i_o = 13.23$)										
i_{oc}/i_{od}		14/1	15/2	16/3	17/4	18/5	19/6	20/7	21/8	22/9	23/10	24/11
z	cm	43.54	44.44	45.22	45.92	46.53	47.08	47.58	48.03	48.44	48.81	49.15
k_f		0.764	0.780	0.793	0.805	0.816	0.826	0.834	0.843	0.850	0.856	0.862
S_f	m ²	29.65	31.76	33.88	36.00	38.12	40.24	42.35	44.47	46.59	48.71	50.82
P_4	%	76.60	46.37	16.14	0	0	0	0	0	0	0	0
P_5	%	23.38	53.58	83.84	85.89	55.62	25.42	0	0	0	0	0
P_6	%	0	0	0	14.09	44.33	74.55	95.17	64.89	34.69	4.45	0
P_7	%	0	0	0	0	0	4.82	35.06	65.26	95.54	74.19	0
P_8	%	0	0	0	0	0	0	0	0	0	0	25.78

The bold font indicates values according to variants A2 and B2, which are respectively the same in variants A1 and B1.

DISCUSSION OF THE RESULTS

With even distribution of all the overlaps and the use of one additional (necessary) winding, the required four layers and partially five (variants A2, B2) and even six (variants A1, B1) are obtained, the larger width of the film affects the increase of the layers above four (5 layers: 0 and 3.21% - variants A1 and A2 as well as 0 and 23.38% - variants B1, B2, 6 layers 11.69% - option B1). For variants A1 and A2 and variants B1 and B2, the proportion of layers and film consumption are the same when the number of wrappings is odd.

With the application of $k_f > 0.75$ and 6 additional wrappings for variant A2 and only four additional wrappings for variant B2, the coating is provided with five and six layers, with the proportion of more layers increasing with the number of wrappings.

Five layers and the same percentages are obtained for variants A1 and A2 using six additional wraps and for B1 and B2 using four additional wraps. The consumption of film in both cases is similar. In the case of variants A1 and B1, a further increase in the number of wraps may result in a deterioration of the tightness, as a result of the re-emergence of areas on the circumference with four layers. For variant B1 the case occurs with five additional wrappings and for variant A1 it occurs twice, for seven and nine additional wraps. This is quite a surprising result confirming the importance of the geometry of the layering, as shown in Figure 3.

CONCLUSIONS

Based on the conducted simulation tests, the following conclusions can be made:

1. A more reliable protection is obtained using a wider film and the factor $k_f > 0.75$. The consumption of the film is similar (variants A2 and B2).
2. At the cost of additional four wraps (only three over necessary) and an additional consumption of 6.35 m^2 , in the case of variant B2, five layers of protection can be obtained.
3. Variant B2 with additional four wrappings seems to be the most advantageous of the four considered in this paper. In addition, in variant B2, the wrapping time is the shortest.
4. Due to the evenly distributed overlaps, the minimum reduction in the width of the film, e.g. due to a higher tensile force or in the case of sliding of the bale during rotation, will not affect the number of layers required.
5. The use of the proposed method of wrapping requires software control of the bale rotation drives motion and wrapping apparatus (or table).

REFERENCES

1. **Baldasano J.M., Gassó S., Pérez C. 2003.** Environmental performance review and cost analysis of MSW landfilling by baling-wrapping technology versus conventional system. *Waste Management* 23 (2003): 795–806. (doi:10.1016/S0956-053X(03)00087-4).
2. **Balsari P. 1990.** La tecnica della fasciatura delle rotoballe per l'insilamento del foraggio. *L'Informatore Agrario*, 22: 33-47, (BN-87/9195-13).
3. **Bisaglia C., Tabacco E., Borreani G. 2011.** The use of plastic film instead netting when tying round bales for wrapped baled silage. *Biosystems Engineering*,

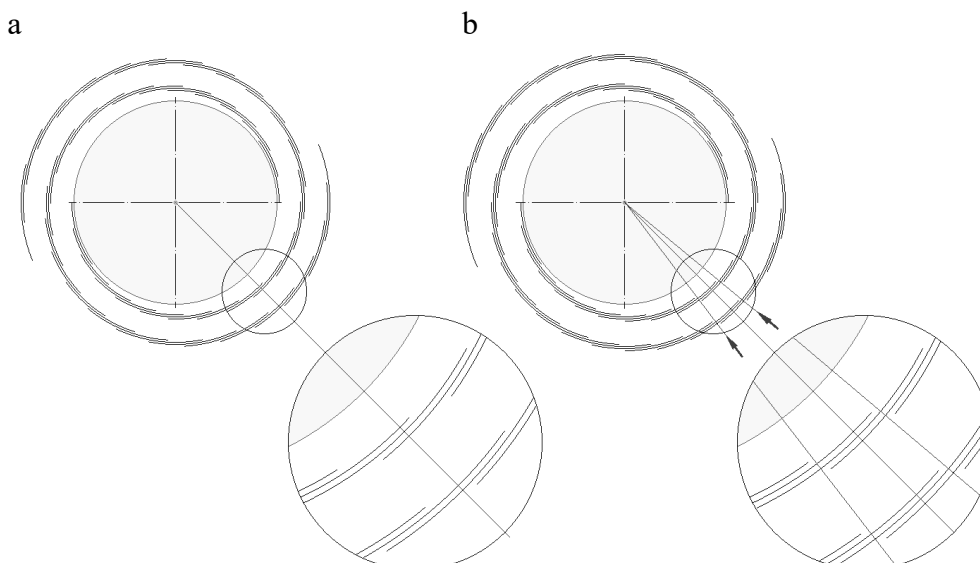

Fig. 3. Geometry of the arrangement of the film strips for variant A1; a - $i_{oc} = 25$, b - $i_{oc} = 28$

- 108(1): 1-8, (doi:10.1016/j.biosystems_eng.2010.10.003).
4. **Borreani G., Bisaglia C., Tabacco E. 2007.** Effects of new - concept wrapping system of alfalfa round-bale silage. *Transactions of the ASABE*, 50(3): 781-787, (doi: 10.13031/2013.23132).
 5. **Borreani G., Tabacco E. 2008.** New oxygen barrier stretch film enhances quality of alfalfa wrapped silage. *Agronomy Journal*, 100(4): 942-948, (doi:10.2134/agronj2007.0258).
 6. **Brüning D., Gerlach K., Weiß K., Südekum K.-H. 2017.** Effect of compaction, delayed sealing and aerobic exposure on forage choice and short-term intake of maize silage by goats. *Grass Forage Sci.*, 1-14. doi: 10.1111/gfs.12345.
 7. **Coblentz W.K., Coffey K.P., Chow E.A. 2016.** Storage characteristics, nutritive value, and fermentation characteristics of alfalfa packaged in large-round bales and wrapped in stretch film after extended time delays. *J. Dairy Sci.*, Vol. 99, No. 5, 3497-3511.
 8. **Demaldé R. 1996.** Fasciatura delle rotoballe per l'insilamento dei foraggi. *Macchine e Motori Agricoli*, 5: 16-22.
 9. **Gaillard F. 1990.** L'ensilage en balles rondes sous film étirable. *Fourrages* (1990) 123: 289-304.
 10. **Hersom M., Kunkle W.E. 2014.** Harvesting, storing, and feeding forages as round bale silage. University of Florida IFAS Extension. EDIS.
 11. **Ivanovs S., Gach S., Skonieczny I., Adamovičs A. 2013.** Impact of the parameters of round and square haylage bales on the consumption of the sealing film for individual and in-line wrapping. *Agronomy Research*, 11(1): 53-60.
 12. **Keles G., O'Kiely P., Lenehan J. J., Forristal P.D. 2009.** Conservation characteristics of baled grass silages differing in duration of wilting, bale density and number of layers of plastic stretch-film. *Irish Journal of Agricultural and Food Research* 48: 21-34.
 13. **Lingvall P. 1995.** *The Balewrapping Handbook. Trioplast. Smålandsstenar. Sweden.*
 14. **Lingvall, P. 1993.** Provning av försträckarnas egenskaper på fyra olika inplastare med marknadens inplastare 1993. *Statens maskinprovningar, meddelande 3368, grupp 39. Uppsala.*
 15. **McEniry J., Forristal P.D., O'Kiely P. 2011a.** Factors influencing the conservation characteristics of baled and precision-chop grass silages. *Irish Journal of Agricultural and Food Research* 50: 175-188.
 16. **McEniry J., Forristal P.D., O'Kiely P. 2011b.** Gas composition of baled grass silage as influenced by the amount, stretch, colour and type of plastic stretch-film used to wrap the bale, and by the frequency of bale handling. *Grass and Forage Science*, 6(2): 277-289. (doi: 10.1111/j.1365-2494.2011.00788.x).
 17. **Nowak J. 1997.** *Analysis and evaluation of the round bale silage production.* Lublin: AR Publishing House (in Polish).
 18. **Savoie P., Jofriet J.C. 2003.** Silage storage, In: D.R. Buxton et al. (ed.). *Silage science and technology.* Agron. Monogr. 42: 405-467. ASA, CSSA, and SSSA, Madison, WI.
 19. **Shinners K.J., Huenink B.M., Muck R.E., Albrecht K.A. 2009.** Storage characteristics of large round and square alfalfa bales: low-moisture wrapped bales. *Transactions of the ASABE*, 52(2): 401-407, (ISSN 0001-2351).
 20. **Stankiewicz A., Stępniewski A., Nowak J. 2016.** On the mathematical modelling and optimization of foil consumption for cylindrical bale wrapping. *ECONTECHMOD*, Vol. 05, No. 3, 101-110.
 21. **Stępniewski A., Nowak J., Stankiewicz A. 2016.** Analytical model of foil consumption for cylindrical bale wrapping. *ECONTECHMOD*. Vol. 5, No. 2, 78-82.
 22. **Tabacco E., Bisaglia C., Revello-Chion A., Borreani G. 2013.** Assessing the effect of securing bales with either polyethylene film or netting on the fermentation profiles, fungal load, and plastic consumption in baled silage of grass-legume mixtures. *Applied Engineering in Agriculture*, 29(5): 795-804, (doi: 10.13031/aea.29.10076).
 23. **Zdobytsky A. 2015.** Mathematical modeling and research results of the strainedly state of polymer tape in the sealing tape rolls. *ECONTECHMOD*. Vol. 4, No. 4, 49-54.