

A conceptual flotation circuit for fine coal processing based on combination of the tree analysis and kinetic data

Mohammad Ranjbar, Mehdi Bazmandeh

Academic Centre for Education, Culture and Research (ACECR), Kerman, Iran

Corresponding author: m_ranjbar@uk.ac.ir (M. Ranjbar)

Abstract: In this research study, we focus on the tree test results as well as the first-order kinetic model to evaluate flotation test data to propose a conceptual design of a flotation circuit for a specific coal sample. Results from the tree test showed it was possible to achieve a product with ash content less than 10% with 8% as combustible recovery and indicated for this coal sample, to obtain low ash – low recovery condition. Kinetic test results showed some of the streams had the same constant, so it could combine streams with similar rates according to configuration aspects. The proposed circuit includes stages (1- rougher, 2- rougher -scavenger, 3- cleaner, 4- cleaner -scavenger, and 5-recleaner) and recleaner concentrate indicated as the final product and rougher -scavenger tailings and cleaner - scavenger tailings also indicated as a final tailing. It is worth noting the proposed circuit is a conceptual design, so the validation of data on a larger scale for the obtainment of the optimized circuit is crucial.

Keywords: kinetic rate constant, tree analysis, conceptual design, flotation, coal

1. Introduction

Flotation is a complex physico-chemical process that is based on the surface chemistry of mineral particles (Ahmed and Jameson, 1989; Bakker et al., 2010; Castro et al., 2013; Bournival et al., 2017a; Li et al., 2018). Complete separation of valuables from the gangue in a single pass is seldom possible. Hence, to achieve effective separation, industries use multi-stage circuits with recycle streams. The performance of these circuits is impacted by both the configuration of the network and the physical and chemical nature of the pulp environments maintained at the flotation cells, and both classes of factors should be considered in circuit design (Hodouin and Flament, 1991; Ketata and Rockwell, 2001; Wills and Napier-Munn, 2006; Ikumapayi and Rao, 2015; Rulyov et al., 2018; Farrokhpai et al., 2020). Tree analysis, widely used to evaluate the grade-recovery-boundary by generating a grade- recovery-curve, is used in evaluating froth flotation circuit separation efficiency (Pratten et al., 1989). This procedure involved repeated branching of the flotation stages and independently generating products from each branch. An initial rougher stage is conducted at a relatively low reagent dosage and the resulting concentrate and tailings are subjected to successive cleaner and scavenger flotation stages with an addition of reagents at each step. This procedure is continued until the final products contain less than 2% of the initial feed mass or until the desired flotation level is reached. Currently, three- or four-step tree analysis has been claimed to be the ultimate test of the grade-recovery-boundary (Ucurum and Bayat, 2007; Chaves and Ruiz, 2009).

Kinetic models are often used in mineral processing, especially flotation process, to describe unit operations which have a strong time dependency (Ahmed and Jameson 1989). Among flotation models, the most acceptable one is the kinetic model which uses the first-order reaction equation. It is based on rules of mass transport from one phase to another. The flotation rate is equal to the rate of change of concentration of floatable material in the cell:

$$-\frac{dC}{dt} = kC \quad (1)$$

where C is the concentration of mass at time t, k is the transport rate or reaction rate and t is the processing time.

Circuit configurations for new cases are usually adopted from those in existing circuits that process similar ores, and these designs are often lacking in quantitative justification (Lynch et al., 1981; Yingling, 1993; Gupta et al., 2007).

Kinetic data are the most acceptable and important to design and optimization of separation circuit in mineral industry such as flotation. Flotation kinetic tests provide set of useful data and information about system to evaluate existing circuits and getting new idea to propose optimal circuit configuration for specific ore. On the other hands, tree analysis results also are very useful to evaluate circuit performance and establishment the future plan of grade – recovery curve. Although, these methods are very popular to investigation the rate behaviour of system and also prediction of circuit performance, there are weak references related to comprehensive description of the combination of kinetic and tree analysis data for circuit design and configuration in coal industry. In theory, the tree procedure should provide the best separation since both the tailings and concentrate are refloats numerous times to ensure that all of the material is properly fractionated according to grade. On the other hand, kinetic test shows the behavior of particles to flotation according to rate phenomena. We use both of the tests to propose a conceptual flotation circuit with mixing of results of them. So, this research focus on the role of kinetic and tree analysis data and depending models to basic design, configuration and study of performance of proposed coal flotation circuit in a batch mode.

2. Materials and methods

2.1. Materials

A coal sample obtained from Tabas coal area, Iran, was used in this research. The sample was screened to pass 500 μm . The particle size distribution of the coal sample is given in Fig. 1 as well as proximate analysis for coal sample shown in Table 1.

Table 1. Proximate analysis for coal sample

Moisture content (wt. %)	Volatile matter (wt. %)	Fixed carbon (wt. %)	Ash content (%)	Sulfur (%)
5.62	30.32	29.25	35.6	1.3

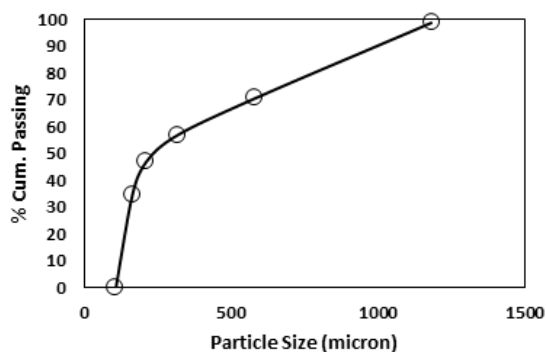

Fig. 1. Particle size distribution of the coal sample

2.2. Flotation tests

In the flotation experiments, gasoil and methyl isobutyl carbinol (MIBC) were used as the collector and frother, respectively. The flotation water used in the experiments was tap water. The flotation tests were divided into two separate stages: 1- Tree analysis and 2- Kinetic tests. It should be said that kinetic study was subprocess tests of tree analysis. The tree analysis procedures were conducted using a 2.5-liter laboratory Denver flotation cell. The collector and frother added prior to and during each experiment respectively. The tree test was performed according to the procedure suggested by Pratten et al. (1989). A four-level tree test has been chosen in this research. After initial flotation test, the resultant tailings were successively refloats with further collector addition to recover any floatable particles that may not have reported to the concentrate. This process was continued until it was estimated that refloatation

of the successive tailings fraction resulted in an individual concentrate with a mass less than 2% of the initial feed sample mass. The concentrate fractions resulting from these successive tailings flotations were then each refloated as many times as necessary until further flotation did not result in additional removal of mineral matter or the concentrate sample to be floated was estimated to be less than 2% of the initial feed mass. After completion of each stage of tree experiment, the kinetic tests were conducted for each product. Kinetic tests were done as following procedure: 300 gr of dry coal and water were added to the cell. The cell was agitated for one minute and then reagents were added, and the pulp was allowed to condition for an additional three minutes. Air was added at the appropriate flowrate and the froth was removed and collected during the following time intervals: 0-30s (product 1); 30-60s (product 2); 60-120s (product 3); 120-180 (product 4) and 180-300s (product 5). All products were filtered, dried and weighed. The ash content of the final products of tree analysis and the combustible recovery of the flotation were obtained. The combustible recovery was calculated from Eq. (2):

$$\text{Combustible recovery (\%)} = \frac{W_C(100-A_C)}{W_F(100-A_F)} \times 100 \quad (2)$$

where WC is the weight of the concentrate, WF is the weight of the feed, AC is the ash content of the concentrate by weight, and AF is the ash content of the feed by weight. The nodal tree tests that used in this research illustrated in Fig. 2.

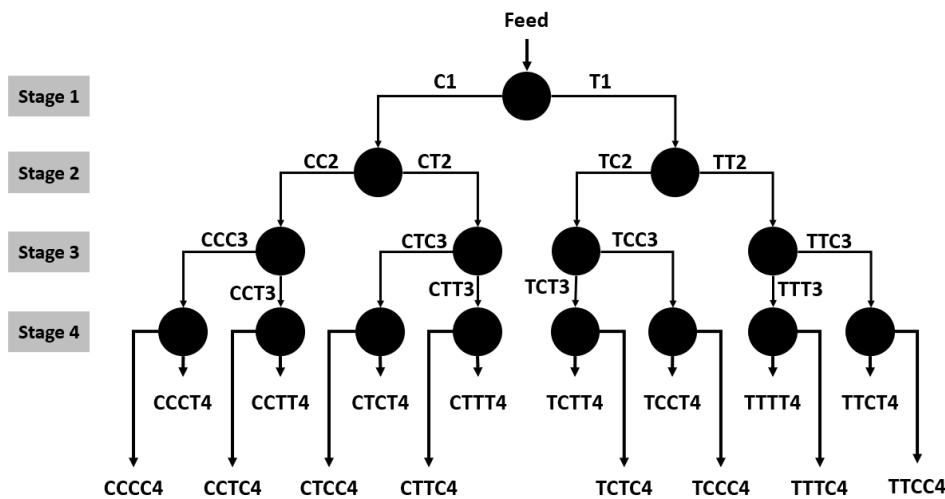

Fig. 2. Nodal representation of tree analysis tests and streams labels (kinetic experiments were conducted for any product of tree analysis stages)

3. Results and discussion

3.1. Tree analysis results

Fig. 3. Indicates the results of tree analysis related to the coal sample. As can be seen from this figure, it is possible to achieve product with ash content less than 10% with 8% as combustible recovery. The results of metallurgical accounting for the nodal flowsheet (indicated in Fig. 2) given in the Table 2. Accordingly, at the level 4, the ash content of final tailings was about 72%.

It should be noted that a proper tree analysis requires separating the sample into fractions containing less than 2% of the original sample weight. For these coal samples, a five-level tree or possibly a six-level tree would be required.

3.2. Kinetic rate constant profile

The cumulative combustible recovery at 30, 60, 120, 180 and 300s was fitted to the first-order kinetic model using the Solver window in Excel software. The flotation rate constant (k_i) was also calculated using the software. Fig. 4 shows the schematic representation of kinetic rate constants related to all streams according to Fig. 2. As can be seen from this figure, high values of rate constant related to concentrate of any stage. This figure also shows the rate constant grouping based on kinetic test results. It should be noted that the lowest rate related to tailing streams (TT2, TTT3, TTTT4) and scavenging

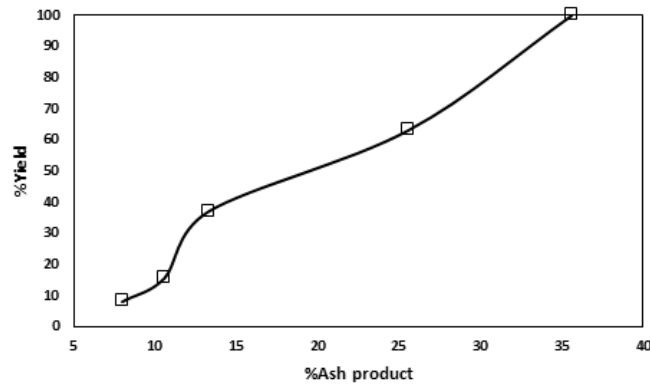

Fig. 3. Separation performance from the tree analysis (labeled according to Fig. 2)

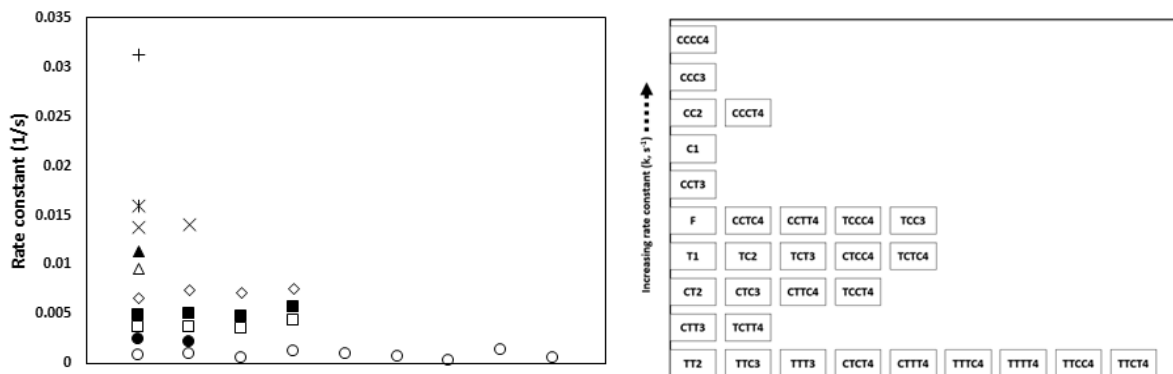

Fig. 4. Kinetic rate constants of any streams according to Fig. 2. (Up: rate values and down: schematic representation with labels)

process of tailings (TTC3, TTTC4, TTCC4, TTCT4, CTCT4, TTTC4) and also bigger ones are about concentrate from rougher (C1), cleaner (CC2) and recleaner (CCC3, CCCC4) circuit. The reason for this may relate to the difference in floatability of the feed used in the rougher and cleaner flotation tests. A large number of difficult-to-float particles were rejected to the tailings in the rougher flotation, and the floatability of the feed in the cleaner flotation was better than that in the rougher flotation since the feed in the rougher flotation was raw coal.

3.3. Circuit configuration

As mentioned earlier, circuit configurations for new cases are usually adopted from those in existing circuits that process similar ores. A proposed circuit is concentrate stream from stage i has been transferred to feed stream of stage $(i+1)$ and tailings from any stage has been collected as final tailings. But, according to results achieved from earlier section, it can be said that some of streams could be recycled to improvement circuit performance based on similarity in rate constant and techno-economical perspective. According to Fig. 4, those streams have similar rate constant can be mix to transfer to another stage. Fig. 5 shows the streams grouping based on approximate similarity of rate constant. As it clear, streams such as C1, CCC3 and CCCC4 were unique in rate value. Due to the fact that to avoid the circuit complexity as well as achievement higher level of overall circuit yield, it can be removed 3th cleaner stage. On the other hand, if the circuit includes only one stage of cleaner unit, the concentrate recovery tends to 15.6% with 33% of yield so, recleaner stage requires to produce low ash coal. Since rate value of CCTC4 was same as CCTT4, it could be said that the stream CCT3 without any further separation process could recycle to the fresh feed. The rate constants of streams TT2, TTC3, TTT3, TTTT4, TTTC4, TTCT4, TTCC4, CTCT4 and CTTT4 had similar values. A reason for this can be there weren't floatable particles compared with the earlier stages so, the rate values were similar and very low. Therefore, it doesn't need to scavenger stage for TT2 stream and it is known as final tailings. It is interesting to said that the rate values of T1 and TC2 were close similar and streams TCC3 and

TCCC4 also approximate same as fresh feed. Therefore, TC2 stream can recycle to the rougher circuit feed. On the left-hand side of circuit, streams CT2, CTC3, CTTC4 were similar and CTCC4 was same as TC2. For achievement of operating conditions and limitations in engineering aspects of flowsheet design, CTC3 could recycle to the feed and also CTT3 recycle to final tailings.

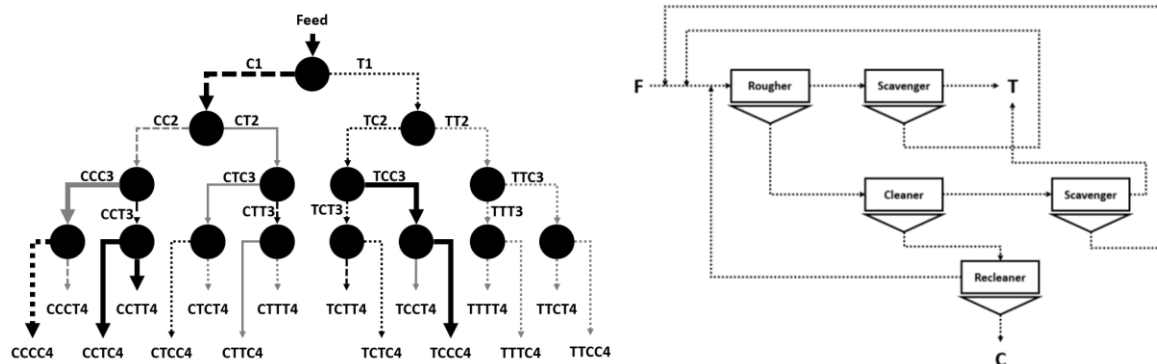

Fig. 5. Streams grouping based of approximate similarity of rate constant (up) and proposed flotation circuit based on kinetic data and engineering aspect of circuit design (down)

4. Conclusions

In this investigation, conceptual design of coal flotation circuit based on kinetic data and tree analysis was presented. Results from the tree test shown it was possible to achieve product with ash content less than 10% with 8% as combustible recovery and also it indicated for this coal sample, to obtained low ash – low recovery condition, a five-level tree or possibly a six-level tree would be required. Kinetic test results used to decide about streams arrangement and circuit configuration to obtained a conceptual flotation circuit as a benchmark of future researches and development. Kinetic analysis of streams indicated some of them had similar rate value, so proposed circuit established based on recycling flows according to engineering aspects and kinetic rate constant similarity. The circuit includes 5 stages (1-rougher, 2- rougher -scavenger, 3- cleaner, 4- cleaner -scavenger and 5- recleaner) and recleaner concentrate indicated as final product and rougher -scavenger tailings and cleaner -scavenger tailings also indicated as a final tailing. It is worth noting this proposed circuit is a conceptual design, so validation of data in larger scale to obtainment of optimized circuit is crucial. Analysing of proposed circuit to perform in the pilot scale of flotation plant and process optimization are future works.

Acknowledgements

We would like to thank the Mineral Processing Laboratory technicians for their assistance in performing the tests required to implement the program.

References

- AHMED, N., JAMESON, G. J. 1989. *Flotation Kinetics*. Mineral Processing and Extractive Metallurgy Review 5(1-4), 77-99.
- BAKKER, C., MEYER, C., DEGLON, D. 2010. *The development of a cavern model for mechanical flotation cells*. Minerals Engineering 23(11-13), 968-972.
- CASTRO, S., MIRANDA, C., TOLEDO, P., LASKOWSKI, J. 2013. *Effect of frothers on bubble coalescence and foaming in electrolyte solutions and seawater*. International Journal of Mineral Processing 124, 8-14.
- BOURNIVAL, G., ATA, S., JAMESON, G. J. 2017. *Bubble and froth stabilizing agents in froth flotation*. Mineral Processing and Extractive Metallurgy Review 38(6), 366-387.
- LI, C., ZHEN, K., HAO, Y., ZHANG, H. 2018. *Effect of dissolved gases in natural water on the flotation behaviour of coal*. Fuel 233, 604-609.
- HODOUIN, D., FLAMENT, F., 1991. *Influence of data collection and conditioning strategies on the significance of performance indices in mineral processing plants*. Proceedings of the International Symposium on Evaluation and Optimization of Metallurgical Performance SME=AIME

- KETATA, C., ROCKWELL, M. C. 2001. *Stochastic evaluation of sampling errors in mineral processing streams*. CIM bulletin 94(1056), 88-91.
- WILLS, BARRY A., NAPIER-MUNN, T., 2006. *Mineral Processing Technology*. Amsterdam: Elsevier, 71-74.
- IKUMAPAYI, F., K. H. RAO. 2015. *Recycling process water in complex sulfide ore flotation: Effect of calcium and sulfate on sulfide minerals recovery*. Mineral Processing and Extractive Metallurgy Review 36(1), 45-64.
- RULYOV, N., T. NESSIPBAY, T. DULATBEK, S. LARISSA, K. ZHAMIKHAN. 2018. *Effect of microbubbles as flotation carriers on fine sulphide ore beneficiation*. Mineral Processing and Extractive Metallurgy Transactions of Institution of Mining and Metallurgy. Section C 127(3), 133-39.
- FARROKHPAY, S., L. FILIPPOV, D. FORNASIERO. 2020. *Flotation of fine particles: A review*. Mineral Processing and Extractive Metallurgy Review, 1-11.
- UÇURUM, M., BAYAT, O. 2007. *Effects of operating variables on modified flotation parameters in the mineral separation*. Separation and Purification Technology 55(2), 173-181.
- CHAVES, A. P., RUIZ, A. S. 2009. *Considerations on the kinetics of froth flotation of ultrafine coal contained in tailings*. International Journal of Coal Preparation and Utilization 29(6), 289-297.
- YINGLING, J. C. 1993. *Parameter and configuration optimization of flotation circuits, part I. A review of Prior work*. International Journal of Mineral Processing 38(1-2), 21-40.
- LYNCH, A. J., JOHNSON, N. W., MANLAPIG, E. V., THORNE, C. G., 1981. *Mineral and coal flotation circuits: Their simulation and control*. Amsterdam, Elsevier.
- GUPTA, A. K., BANERJEE, P. K., DUTTA, A., MISHRA, A. (2007). *Recovery of clean coal fines through a combination of gravity concentrator and flotation processes*. Mineral Processing and Extractive Metallurgy Review 28(4), 299-319.
- PRATTEN, S.J., BENSLY, C.N., NICOL, S.K. 1989. *An evaluation of the flotation response of coals*. International Journal of Mineral Processing 27(3-4), 243-262.