

KRZYSZTOF KRAUZE  
KRZYSZTOF KOTWICA

## Innovative mining machinery solutions developed at Department of Mining, Dressing, and Transport Machines, AGH University of Science and Technology

*The exploitation of mineral resources with underground mining methods is becoming more and more difficult due to the mining and geological conditions in which these resources are present. This is related to the depth of retention and thickness of the exploited deposits (seams), more cohesive and durable rocks, and climatic conditions. The excavation of access and preparatory roadways as well as exploitation under such conditions require specially designed and manufactured machines. In recent years in the Department of Mining, Dressing, and Transport Machine at AGH University of Science and Technology in Krakow, a number of innovative solutions of machines and devices have been developed that can be used to work under difficult mining and geological conditions. This article presents selected solutions of these machines and devices – a mining head for a roadheader with asymmetrical disc tools with a complex motion trajectory, a temporary, mechanized, and walking roadway support, a unique longwall complex with a single-cutting head shearer used for thin coal seam exploitation, and an innovative mining and hauling system for mechanical shaft drilling using a shaft shearer.*

Key words: *innovative solutions, mining machines, hard rock mining, performance, safety*

### 1. INTRODUCTION

---

The mining and geological conditions under which the mineral raw materials exploited by underground methods are covered are becoming more and more difficult in Poland. This is related to the greater depths of their retention, climatic conditions, and harder and harder rocks. This means that the currently used technologies of opening-out and excavating minerals are increasingly unreliable or do not allow us to achieve satisfactory performance. In order to meet this problem, the Department of Mining, Dressing, and Transport Machines has been working for many years on developing machines and devices that will be able to work efficiently under difficult mining conditions.

First, a number of unique research stands have been developed and completed, on which research

on the use of new mining tools and techniques for the mining of compact rocks have been conducted. These are, among others, a laboratory standstands for rock mining using single tools (Fig. 1a), rock mining using disc tools (Fig. 1b), and rock mining with milling screw heads (Fig. 1c).

The results of the tests carried out on these stands (shown in Figure 2) have allowed for the development of new tools and cutting heads that can be used while mining hard and very compact rocks. The most promising direction is the use of mini symmetrical and asymmetrical disk tools in the rock mining process and the so-called undercutting technique. This technique allows us to reduce the energy consumption of the mining process and increase the granulation of the output as compared to the technique of milling or static crushing.

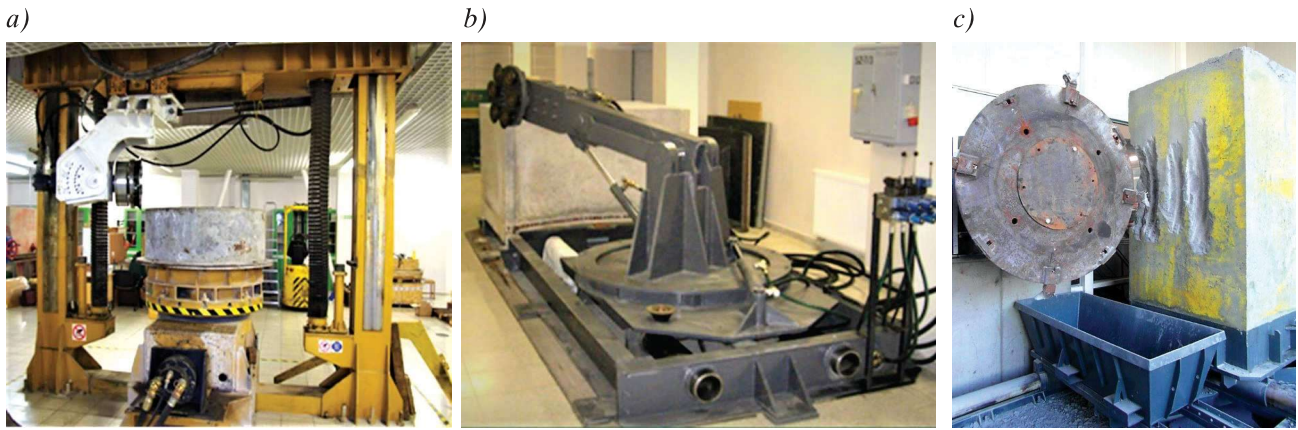

Fig. 1. Laboratory stands for testing rock mining: a) with single tools; b) with disk tools; c) with screw milling heads

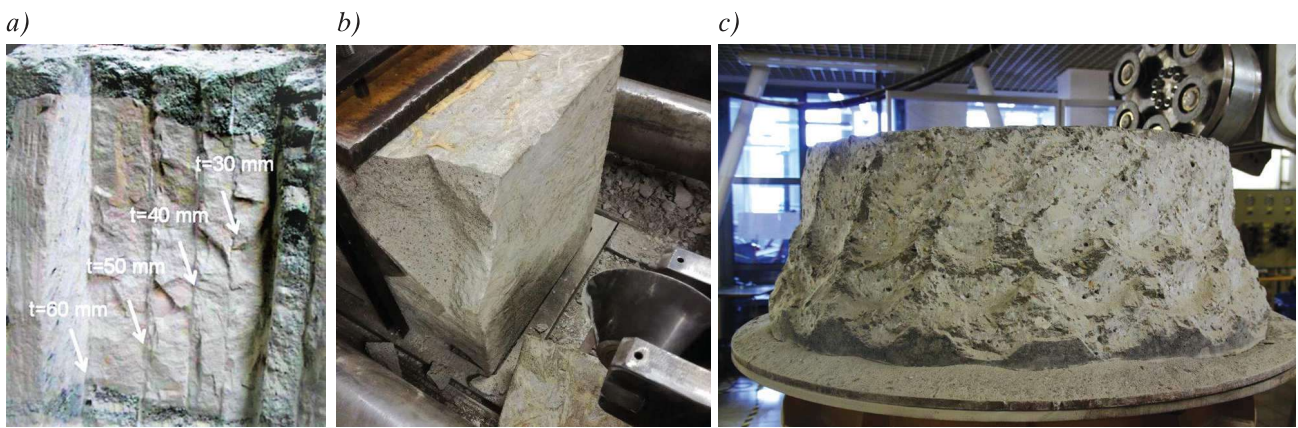

Fig. 2. Results of tests of rock mining using: a) single plate with disk tools with simple trajectory; b) single disk tool; c) single plate with disk tools with complex trajectory

However, using the experience gained during the implementation of the research work in the mining industry, it was also proposed to develop atypical and innovative machine solutions that can be used in the exploitation of low coal seams, opening-out heading and tunnel drilling, and shaft drilling. The results of this work conducted at the Department of Mining, Dressing, and Transport Machines are presented in this article.

## 2. INNOVATIVE SOLUTION OF MINING HEAD FOR ROADHEADERS

In Polish underground mining, plenty of dog headings are drilled with mechanical methods using arm roadheaders equipped with milling units. The cutting tools applied on the units (rotary tangent bits) are under unfavorable mining and geological conditions or improper work conditions and are, thus, affected by an accelerated wear process. This influences

the speed and cost of drilling such excavations. In the Department of Mining, Dressing, and Transport Machines at AGH University of Science and Technology in Krakow, asymmetrical mini disc tools for use on the mining heads of roadheaders have been proposed. Asymmetrical disc tools are applied in the technique of mechanical mining not only as crushing devices but also as chipping ones. The principle of the incision technique is the mining of a rock by cutting it off towards a free space.

A disc tool affects the rock tangentially to the surface of the mined body (similarly to a cutting tool); however, the difference is that it uses a disc rolling movement, which efficiently eliminates sliding friction in favor of rolling friction. Application of disc tools in this way lowers energy consumption and pressure force, which allows for constructing a mining machine with respectively lower energy parameters and lower requirement concerning stability as compared to classical crushing discs operating perpendicularly towards the surface of the mined body [1–3].

On the basis of an analysis of the world technique condition and results of our own tests of rock mining with asymmetrical disk tools, a new conception was elaborated featuring a unit in which the motion of the tools will be forced, causing the mining of a rock body with tools along a complex trajectory. This allows for the crossing of mining lines of individual disc tools and facilitates the mining of compact rocks through breaking off rock furrows. It decreases the energy consumption of the process. In this case, disc tools were mounted on separate plates that are able to rotate on the mining unit casing and are propelled independently from it.

The project and model of the new solution of a mining head with disc tools of a complex trajectory were performed in cooperation with the REMAG company (currently FAMUR Ltd.) – the leading Polish producer of roadheaders. It was planned to

work out and adapt the new head solution for the KR 150 medium roadheader manufactured by REMAG. On the basis of an analysis of the milling heads used on the miner, it was assumed that the length of the new solution should not exceed 1750 mm, with a diameter of less than 859 mm and weighing less than 5 tons. The elaborated initial model of the head was comprised of mounting three plates with disc tools on its body. The casing body will have the ability of independent rotation as related to plates with disc tools. The kinematic capabilities of the new head solution are presented in Figure 4 [1, 3].

On the basis of the elaborated model, a technical design and prototype of the head were developed for mounting on the KR 150 miner and the initial field tests in REMAG Ltd. These tests were carried out on a large-size concrete block of a uniaxial compressive strength of about 80 MPa. The best effects of the work

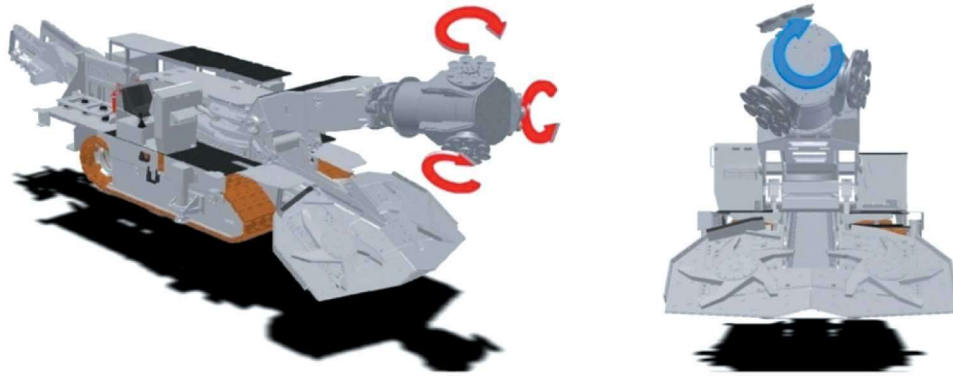

Fig. 3. Kinematic capabilities of new head solution mounted on roadheader KR 150 [3]

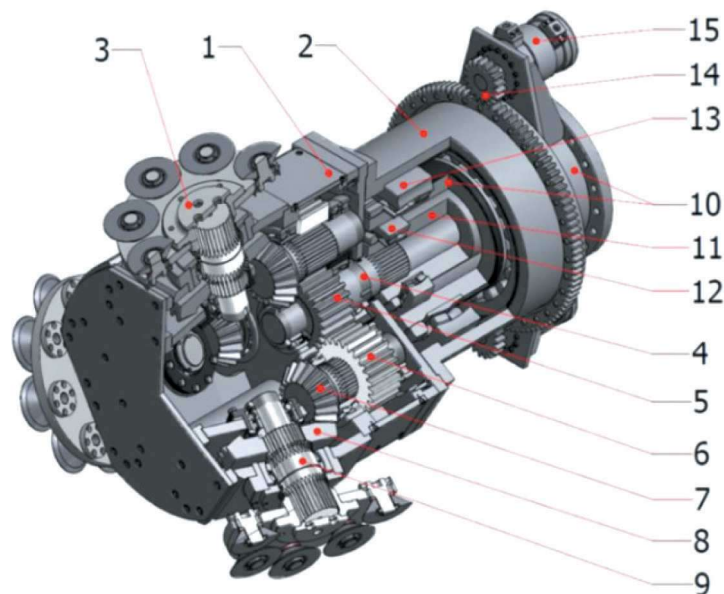

Fig. 4. Model of new head solution with disc tool of complex trajectory [3]: 1 – main gear, 2 – auxiliary gear, 3 – disc plate, 4 – input shaft, 5 – central gear wheel, 6 – orbital gear wheel, 7 – pinion, 8 – face gear, 9 – output shaft, 10 – support, 11 – connector, 12 and 13 – bearings, 14 – body gear, 15 – hydraulic engine



– the large graining of the winning, low engine load, and limited vibrations – were obtained for the head body rotations of ca 20 rpm at a plates rotation value of ca 60 rpm, with the head body rotating in a counter-clockwise direction and the plates with the disc tools rotating in a clockwise direction.

No considerable symptoms of disc tool wear were noticed for these working parameters. A view of the obtained winning and a typical surface of the mined block (intersection of the cutting lines) is shown in Figure 5.

An increase in the rotations of the plates with disc tools increased the dustiness, and at maximal rotation, sparking even occurred at the contact of the tools with the rock. Whereas, a change of the direction of the head body or the plates with disc tools rotating in the opposite direction had a highly negative influence on the engine load as well as excess wear on the disc tools and plates themselves.

The wear of the plates with disk tools is eliminated by modifying the design of these plates. Instead of flat

and round plates, plates in the shape of flowers were built, with external elements tilted at an angle of about  $-15^\circ$ . A view of such a modified plate is shown in Figure 6a. In subsequent tests, no wear was found in the plates. For the next tests, another plate and a universal disc tool holder were designed to allow the disc tool to be mounted in at least three positions by twisting it on a plane passing through the plate's axis. The version with an interchangeable monoblock for three disk tool settings in relation to the disk (at  $-5^\circ$ ,  $45^\circ$ , and  $90^\circ$  angles in relation to the plate axis) was adopted as the most advantageous. Figure 6b shows a plate view with monoblocks in a version that allows for mounting disk tools perpendicular to the axis of the disk; i.e., at an angle of  $90^\circ$ .

The tests performed for the disk tools mounted at angles of  $-5^\circ$ ,  $45^\circ$ , and  $90^\circ$  with respect to the plate axis have shown that setting the tools at an angle other than  $-5^\circ$  to  $-15^\circ$  results in serious damage in a very short time in the form of chipping and breaking the edges of the tools. Therefore, in the next tests,

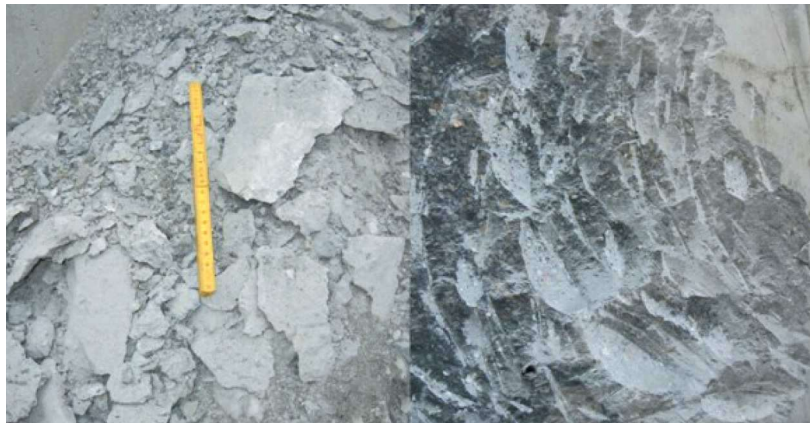

Fig. 5. View of winning and surface of mined rock block obtained for most favorable set of direction and revolution number of head body and plates with tools [2]

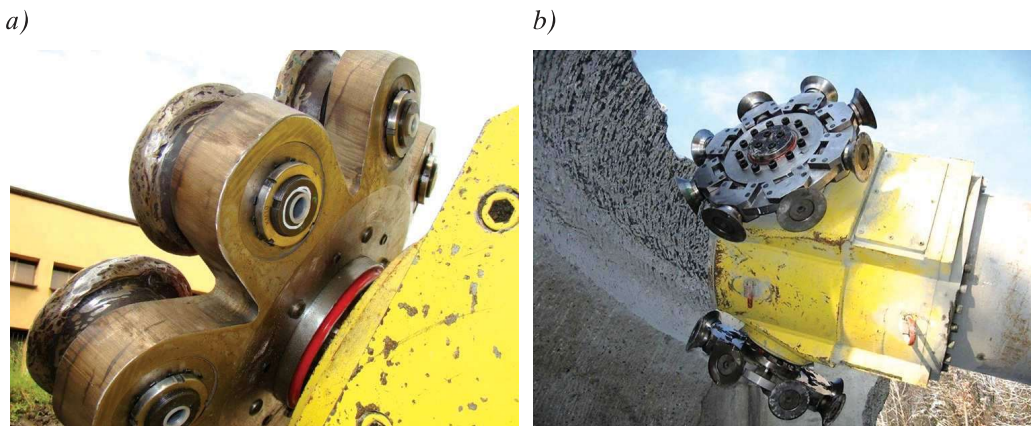

Fig. 6. View of: a) modified solution of plate with disk tools mounted at  $-5^\circ$  angle; b) new universal solution of plate with disk tools mounted in interchangeable holders at  $90^\circ$  angle [2]

the disc tools were mounted only in the holders at an angle of  $-5^\circ$ . Attempts to install tools armed on the perimeter with sintered carbide inserts instead of smooth disk tools was also unsuccessful. In addition, after a very short period of operation, these tools were seriously damaged – a large number of carbide inserts were broken off. The views after the attempts of the disk tools mounted at an angle of  $90^\circ$  and the disk tools armed with sintered carbide inserts are shown in Figure 7 (and are compared to smooth discs mounted at an angle of  $-5^\circ$ ).

The new mining head solution has been adapted for mounting on the produced by FAMUR S.A. FR 250 roadheader arm (Fig. 8), which has greater power and is heavier. The conducted concrete block mining tests showed that this roadheader is more suitable for using the disc mining head than the KR 150 roadheader. The mining head worked in a much more stable fashion.

The proposed solution of the mining head with asymmetrical disk tools with the complex trajectory of motion showed its usefulness during the mining of hard rocks; it can be used as an alternative to the milling heads of the roadheaders. In order to obtain the best working parameters of the mining head (large grain size of the output, low load of the drive motors, and limited vibrations), it is also necessary to choose the right direction and rotary speed value of the mining head body and plates with the disk tools. However, it is purposeful to carry out further tests to develop the technology of its operation during the excavation of galleries and tunnels.

On the basis of the results of the conducted field tests, it was also found that the method of their setting in relation to the discs axis and the material from which they were made are very important for the efficiency of the mining and durability of the disc tools.

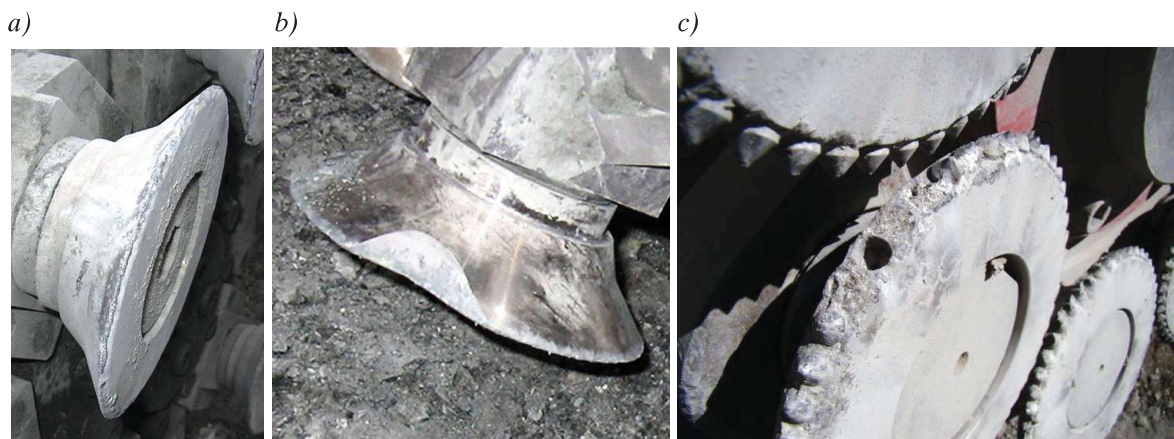

Fig. 7. View of wear of disk tools after mining tests: a) mounted under  $-5^\circ$  angle; b) mounted under  $90^\circ$  angle; c) armored with carbide inserts [2]



Fig. 8. View of mining head with disc tools mounted on type FR 250 roadheader during field tests



The most favorable is to set them so that the axis of rotation of these tools is inclined at an angle within a range of  $-5^\circ$  to  $-15^\circ$  relative to the axis of plate rotation. It is also suggested to include an automatic arm control system to ensure smooth movement of the mining head in a future solution.

### 3. TEMPORARY, WALKING, MECHANIZED MINE ROADWAY SUPPORT

In the process of gallery drilling, regardless of the drill method used (drilling and blasting material firing or mechanical mining), one of the longer-lasting operations is the assembly of a gallery lining. It often absorbs up to 40% of the total time spent for gallery drilling. Reducing the time of this operation is possible, for example, by using mechanized work platforms, allowing for the assembly of large lining elements outside the gallery face and transporting them to the face after finishing the mining process. In the Department of Mining, Dressing, and Transport Machines, it was decided to return to the ideas implemented in the 1980s; i.e., a mechanized temporary roadway support. This allows the machines to work under a roof secured by such a support; in parallel, behind this support the process of assembly the final lining is carried out. The temporary linings used at that time did not have great possibilities to adapt to the variable geometric parameters of the gallery; also, their cyclical extending and sliding negatively influenced the condition of the gallery roof [4].

In the Department of Mining, Dressing, and Transport Machines, it was assumed that the support would be adapted for cooperation with both drilling machines – the roadheader and the machines used in the traditional explosive method. In addition, it will be able to increase its length by adding modular segments up to 16 m, and an LP-type arc steel lining will be mounted behind it. Another difference will be the offloading of the floor elements of the support during the movement as well as moving the support in contact with the roof. Based on the above assumptions, a preliminary concept of a temporary mechanized walking support has been developed. It was designed as a modular construction with the possibility of adding or subtracting individual segments [4, 5]. A view of a support set consisting of six segments is shown in Figure 9.

The support consists of two marginal sets (1) and four identical inside sets (2). In the lower straight-lined segment, the arcs are equipped with shift cylinders having a stroke of  $300 \text{ mm}^3$ , whereas the nominal support dimension is obtained for a shift cylinder advance of 150 mm (the remaining 150 mm is considered to be a reserve). The individual segments are joined together via four feed cylinders (4). Because of the operational mode, the marginal shift cylinders are two-side acting, and the others are one-side acting. In addition, the arcs are joined together with pipe-type guides (5) assuring their stability during the drawing-off phase. Moreover, a considerable part of the support set is covered with a special shield, which is designed in such a manner that it protects the heading against rock waste, plays the role of

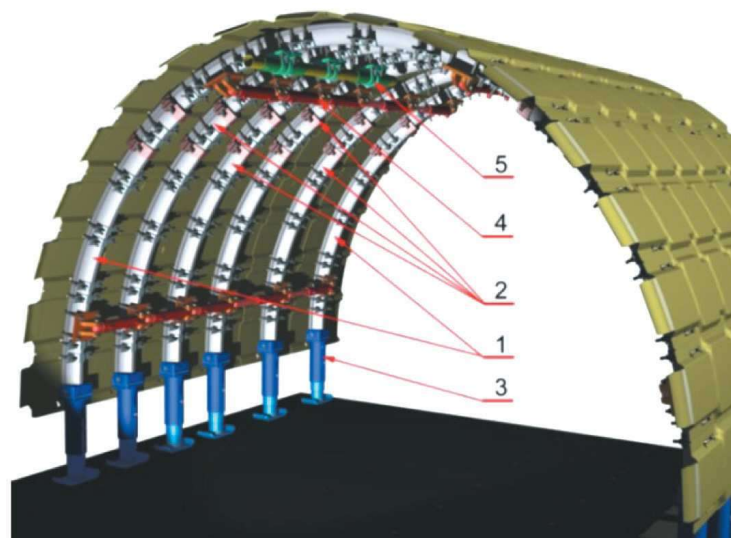

Fig. 9. Model of mechanized temporary roadway support [9]: 1 – marginal sets, 2 – inside sets, 3 – shift cylinders, 4 – feed cylinders, 5 – pipe-type guides

a guiding element, and allows for sheet metal plates and other equipment to be mounted on the arcs. In the case of the presented solution, the mechanized temporary support is adapted for driving the roadways of cross-sections tailored to the support of LP 9 and LP 10 (depending on the type of applied arcs). Just one set relative advance of the other amounts to 280 mm; this results from the assumed feed cylinder strokes. The scale (i.e., the distance between the individual segments during machine operation with an advanced shift cylinder) amounts to 900 mm [5].

After installing the support set to the length determined by the type of roadheader or mining and loading machine, it is possible to start the work cycle. As the face of the gallery advances, individual segments of the support are robbed (offloaded) by sliding the hydraulic actuators placed in the support feet (starting from the gallery face and moved forward by means of actuators). After moving the individual segment, it is spread again; then, the sequential moving of the remaining support segments to the last one is carried out. Due to the ratio of the mining web to the stroke of the feed hydraulic actuator, it is assumed to control two or three arc sets in one cycle. For the proper implementation of this operation, it was necessary to develop and execute a control system for individual segments of support.

On the basis of the developed project at the Hydromel Factory, a prototype of a six-element temporary mechanized roadway support with a power supply and control system was made (Fig. 10). During the

workplace tests, the support correctly performed all of the assumed activities. The further part of the trials was carried out in the Janina Coal Mine in Libiąż, Poland underground conditions. These tests also showed no major problems during the operation of the new temporary support. Only the hydraulic power and control system should be modified in terms of its automation; currently, the control is carried out manually.

As mentioned above, the temporary support is adapted for cooperation with the roadheaders and machines used in the explosive method. In both cases, these machines work under the protection of a temporary support – the length of which can be as much as 16 meters. Figure 11 shows the model of cooperation of the temporary mechanized support enclosure with a roadheader. All machines and basic devices of the roadway complex (1 to 5) are located under the support, successively moving forward as the gallery face is being drilled. Behind the support, the LP (8) final steel arc lining is installed. You can use ready-made solutions of work platforms with manipulators (6, 7). The Department of Mining, Dressing, and Transport Machines has developed its own concept of such a platform with a manipulator (Fig. 12), moving on a rail suspended under a previously made LP steel arc lining. The platform is equipped with a hydraulic manipulator, the construction of which allows for both lifting the lining elements from the floor as well as their movement and assembly into the ready arches of the lining [6].

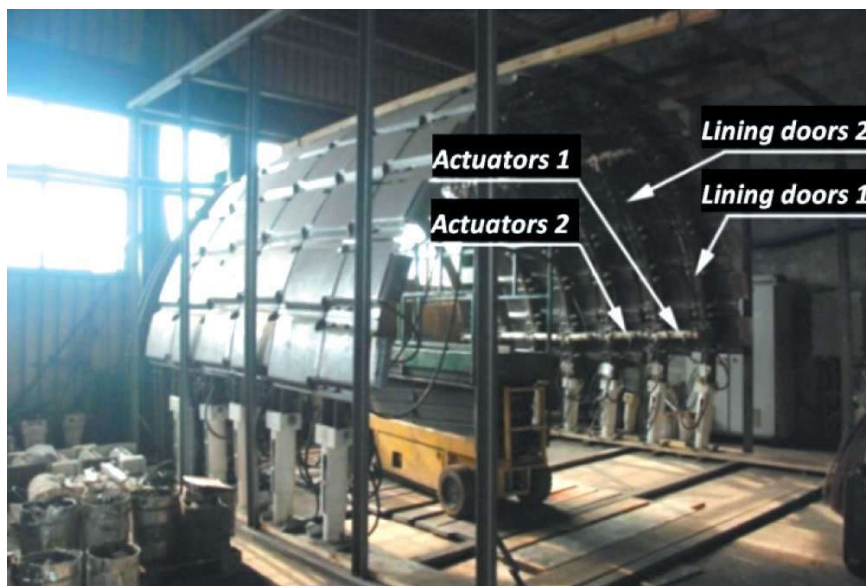

Fig. 10. View of mechanized temporary roadway support before field tests

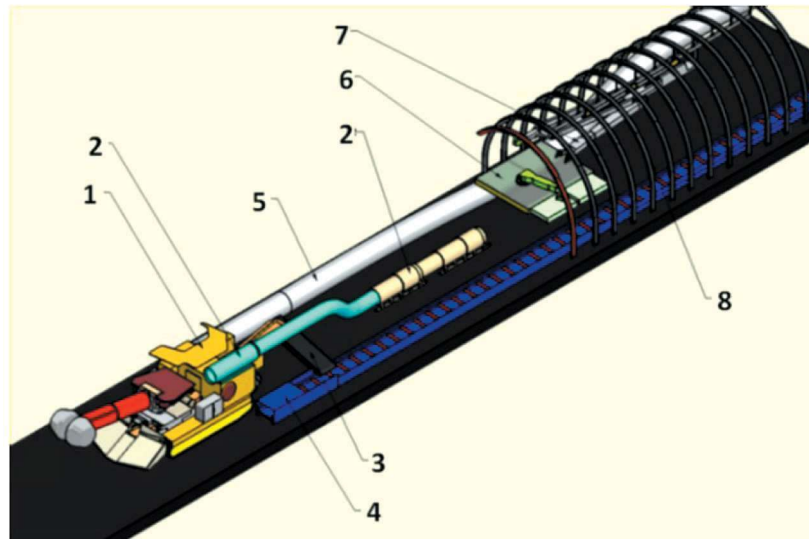

Fig. 11. Model of collaboration of mechanized temporary roadway support with roadheader: 1 – roadheader, 2 – dust precipitator, 3 – bridge conveyor, 4 – chain conveyor, 5 – ventilation pipe, 6 – working platform, 7 – manipulator, 8 – steel arc lining LP

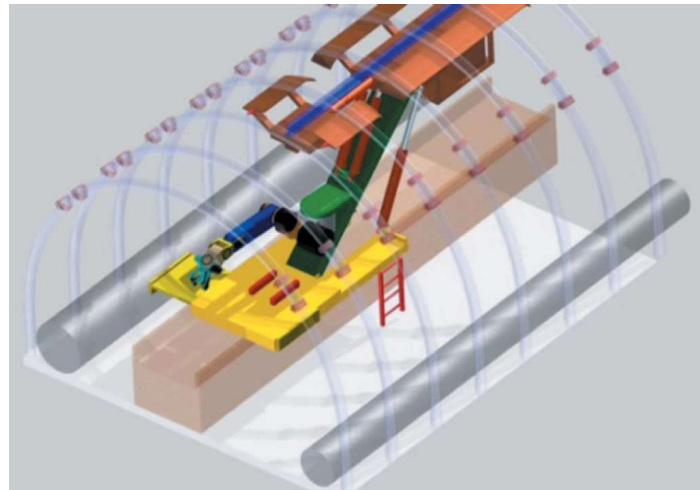

Fig. 12. Concept of working platform with manipulator for final assembly of steel arc lining LP [6]

#### 4. LONGWALL COMPLEX WITH SINGLE-CUTTING HEAD SHEARER USED FOR THIN COAL SEAM EXPLOITATION

In Poland, underground mine coal covered in thin coal seams constitutes a significant part of the resources, and the low heights of the seams cause a number of limitations affecting the efficiency of coal mining. Currently, coal plows are used for exploiting these thin seams. On the other hand, longwall shearers are considerably less effective when used in thin seams, and the efficiencies are sometimes even several times lower. This is connected with the difficult loading of winning. In the Department of Mining, Dressing, and

Transport Machines, a new solution for a mining machine intended for coal mining in low walls with only one mining head has been developed. The thin-seam shearer fulfills the following requirements that differ from those used so far: separation of the milling process from the loading process, the use of a chain feed system, and the possibility of starting a new cut without the necessity of slotting.

In the scheme in Figure 13, the locations of the individual components of the longwall complex are shown: the mechanized longwall system is equipped with a single cutting head (1), a face armored conveyor (2), a stage loader (4), and a mechanized longwall support (3). The location of the face armored conveyor



drives (6) and the drive units of the shearer advance (5) decides the location of the driver chain, which is located at the goaf side. The orientation of the shearer advance drives (5) (perpendicular or parallel) is arbitrary [7, 8].

A concept of the single cutting head shearer is shown in Figure 14. The shearer consists of the body (2), a centrally mounted single cutting head (1), and two overhead loaders (3, 4). The loader (3) is in the active position, whereas the loader (4) is in the standby position. The shearer is pulled on conveyor troughs (5) with use of the chain (6). The chain (7) is a passive branch for a given velocity.

The diameter of such a shearer is matched to the coal seam thickness, and the selected cutting head has no screw plates. Normally realized by the screw plates, the loading function is now realized by the loaders. Separation of the loading process from the cutting process is one of the major advantages of the presented solution. During longwall shearer operation, its kinematic parameters can be increased without risks related to the problems of loading material onto a conveyor, which was the major factor limiting the output increase. The loading of the winning

onto the conveyor is executed by the loader (which is assembled after the direction change), whereas the second loader is set into operational position.

The shearer moves traditionally along the conveyor; however, the chain advance system (which is realized via drive units located in the roadways) is applied. Such a solution allows for a considerable decrease in the shearer's overall dimensions, as the drive units are removed from the shearer body. Moreover, in the case of a break down, the shearer can be pulled away into the roadway, which eliminates the necessity of entering the longwall (i.e., repairs executed in limited space).

The determined geometrical and kinematic parameters of the single cutting head longwall shearer, face armored conveyor, and longwall mechanized support allowed for the development of the preliminary project of the longwall complex in question (as well as its 3D in model the program Autodesk Inventor) (Fig. 15). The longwall shearer system consists of a single cutting head shearer (1), a face armored conveyor (2), a mechanized section of the longwall support (3), and a stage loader. At both ends of the longwall conveyor, its drive (5) and drive (6) of the shearer are mounted.

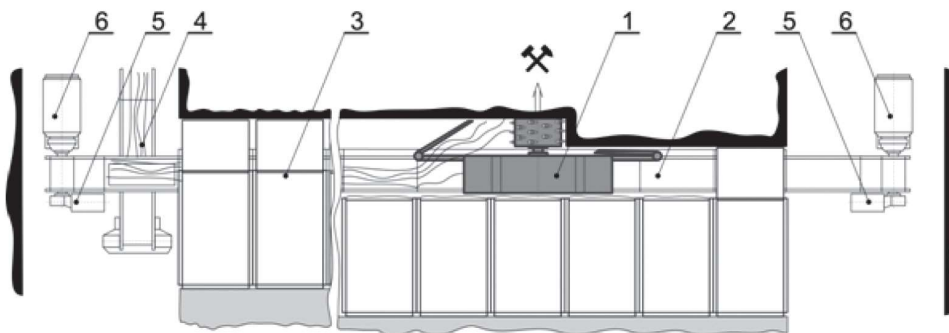

Fig. 13. Scheme of mechanized longwall system equipped with single cutting head shearer [7]

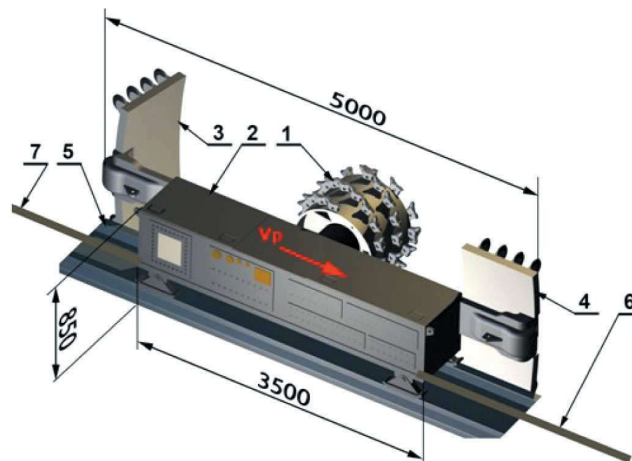

Fig. 14. Concept of single cutting head longwall shearer [7]

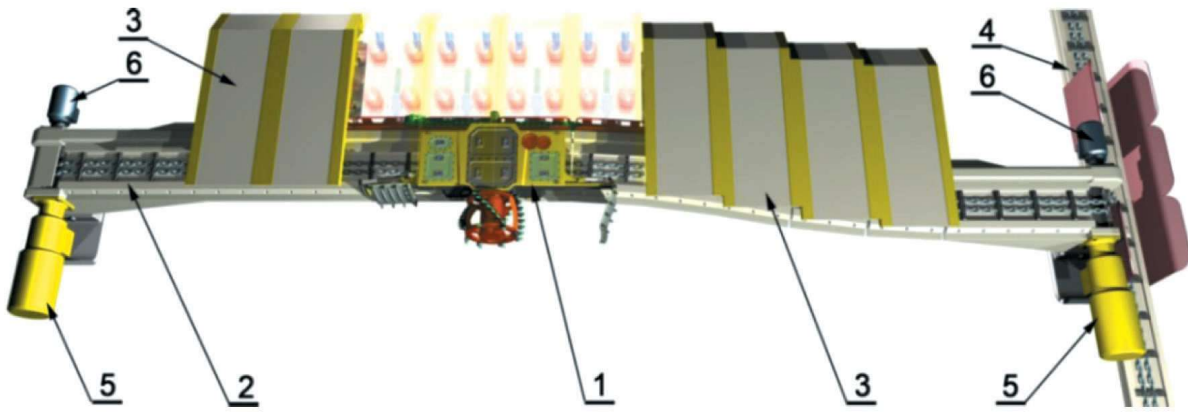

Fig. 15. Model of mechanized longwall system equipped with single cutting head shearer [5]

The shearer body is designed in such a manner that there is enough space for a  $2 \times 120$  kW drive unit for the cutting head (according to actual solution reviews) together with a planetary gear, safety devices, a lubrication system, and a water cooling system. Besides the driving devices, a hydraulic system powered from the cutting head drive as well as automation, control, and diagnostic systems are provided. The hydraulic system assures a change in the loader's position and is also used for a shearer shifting along the slippers. The size of the individual elements was selected taking into account the shape and size of the actually used subassemblies of the longwall shearers and coal plows.

The designed system of the thin coal seams exploitation equipped with a single cutting head shearer is designed for two-way mining operation technology. A lack of a slotting phase and full web mining on the whole longwall length are major characteristic features of the technology in question. Cutting head replacement in the case of a seam thickness change is possible, and the control system of machine operation is operated via corrective servo motors.

## 5. INNOVATIVE MINING AND HAULING SYSTEM FOR SHAFT SHEARER

Shaft drilling technology in Poland is based primarily on the blasting method; however in the LGOM district, it is also made with a special technology that uses mechanical rock mining with strengths up to 35 MPa. In this case, the mining machine used in the KDS-2 shaft shearer is the KWB-6 longwall

shearer arm adapted for this purpose (equipped with one milling worm organ mounted with radial picks). The prevalent mining and geological conditions in the drilled shafts enforce the use of freezing the rock mass. The KDS-2 shaft shearer is adapted to cooperate with various types of equipment installed in the shaft face (and with a grab loader in particular). The process of shaft drilling consists of mining the bottom of the shaft using a milling worm organ and loading the output with a grab loader. The properties of the excavated rock mass and the technology of the organ's operation (vertical axis of its rotation – Fig. 16) make it difficult to cut the bottom of the shaft due to its sticking. Therefore, breaks are required to clean the mining head body as well as output the loading during the operation of the shearer [9].

Taking this under consideration, the Department of Mining Machines proposed the concept of a new generation of a shaft complex that will carry out the following processes in parallel. Mining is implemented as a continuous process by the milling mining head attached to the working platform in a way that allows for mining the entire bottom of the shaft. The loading and output haulage are carried out continuously by the scooping (plowshare loader) and a set of belt and bucket conveyors. Temporary supporting of the side walls with steel panels is realised at the same time using integrated hydraulic cylinders. This complex is designed for shaft drilling with a diameter of 8.5–9.5 m. The developed concept utilizes the construction proposed by ITG KOMAG (the spreading system and arm of the mining head). The shaft complex model developed on the basis of this concept is shown in Figure 17 [10].



Fig. 16. View of suspension boom of mining head drive system together with head and mining cutter in KDS-2 shaft shearer [9]

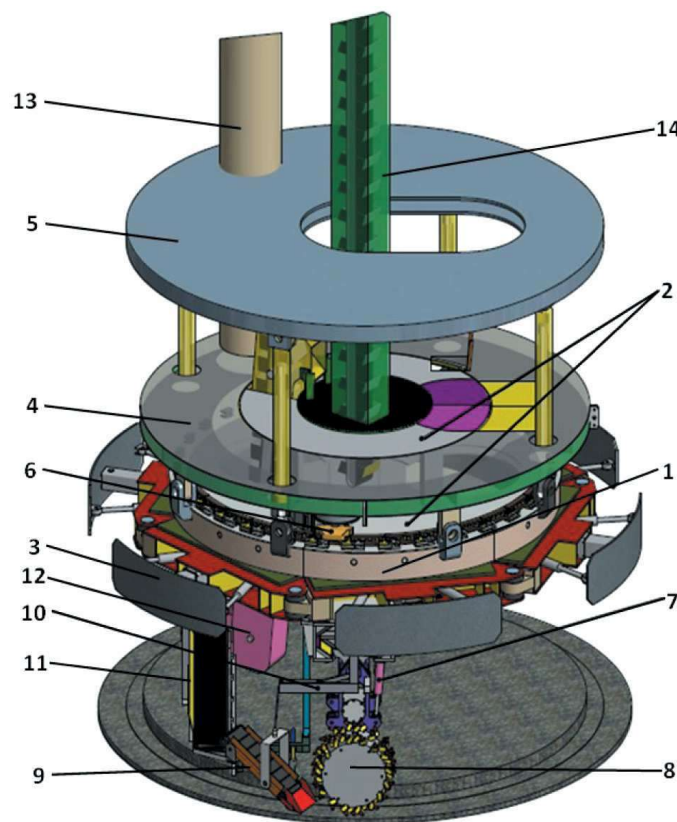

Fig. 17. Model of developed shaft complex [10]: 1 – working platform, 2 – rotary ring, 3 – expanding system, 4 – fixed working platform, 5 – permanent working platform, 6 – drive of working platform rotation, 7 – actuators for arm lifting, 8 – milling mining head, 9 – short belt conveyor, 10 – actuators for short belt conveyor lifting, 11 – linear belt conveyor, 12 – overflow and short bucket conveyor, 13 – ventilation pipe-line, 14 – long bucket conveyor

An innovative solution for a shaft shearer is a mining and loading unit (Fig. 18). The mining unit includes a longwall shearer arm with a mining head, two arm lift cylinders, and a lifting system of a short conveyor with a mining head arm. The shearer arm is an adapted arm of the longwall shearer with a milling mining head driven by a 250-kW motor. The mining head slotting takes place by means of two cylinders

placed on one side of the arm. When slotting, the platform rotating ring rotates at the working speed.

During the rotation of the platform rotating ring, the mining head makes cuts with a rectangular cross-section and width equal to the web of the mining head and the height equal to the depth of the mining. After one cut, the mining head is lifted; then, the platform rotary ring returns to the starting position.



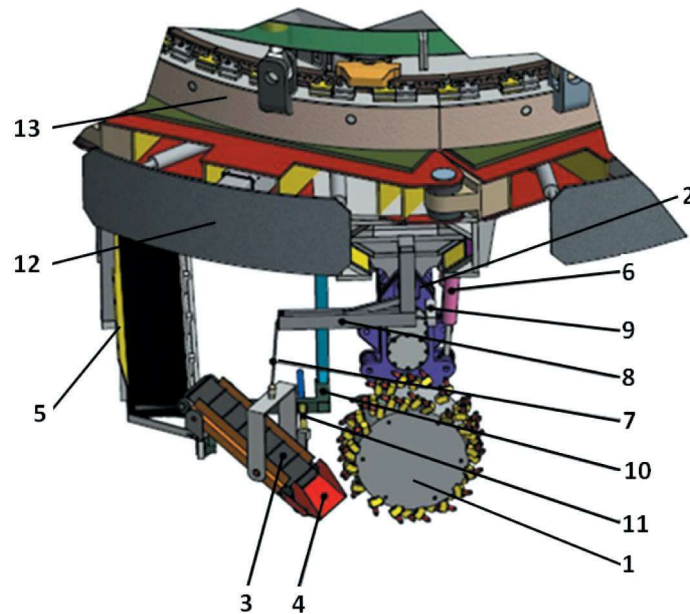

Fig. 18. Model of innovative mining and loading device developed for shaft complex [10]: 1 – milling mining head, 2 – arm, 3 – short belt conveyor, 4 – scraper, 5 – linear belt conveyor, 6 – actuators for arm lifting, 7 – steel rope, 8 – actuators for short belt conveyor lifting, 9 – rope fixing, 10 – conveyor moving system, 11 – conveyor rotation actuator, 12 – expanding system, 13 – rotary ring

It is necessary to slot the mining head in the new section; i.e., in a new position, towards the axis of the shaft, with the value of the mining head web. During the slotting for subsequent cuts, the mining head moves along the linear guide in the direction of the shaft axis simultaneously with the rotation of the ring, which results in the spiral movement of the body until it reaches the position in the new cutting. The execu-

tion of subsequent cuts takes place in the same way until the whole shaft bottom layer is mined (Fig. 19). During the phase of slotting and normal mining, the short belt conveyor moves behind the mining head and hauls the output to the horizontal (linear) belt conveyor [11].

The conveyor set is the last “link” of the closed operation of the shaft shearer. Through the scraper

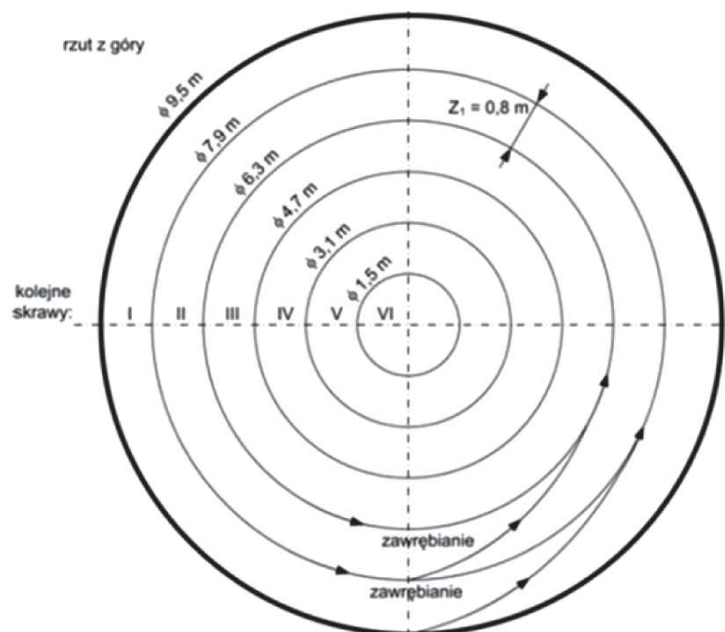

Fig. 19. Diagram of technology of making subsequent cuts of bottom of shaft [11]

and short belt conveyor, the output from the mining head is loaded onto the horizontal belt conveyor and then moved to the dumping unit. From the dumping unit, the output is removed by a short bucket conveyor and transported to the output bunker. From the output bunker, the bucket conveyor hauls the output outside the working platform to a height set by the user. The short conveyor is lifted by means of a steel cable connected through a lifting system between the shearer's arm and a short conveyor belt. An actuator has also been introduced to allow the short belt conveyor to straighten (relative to the horizontal conveyor) during the passage of the mining head arm to the center of the shaft.

At the same time, the presented shaft complex carries out the process of mining, loading, and hauling the output from the bottom of the shaft. The cutting width of the mining head was set at 0.8 m (with an acceptable value of 1.0 m). According to the adopted assumptions, the mining takes place by means of the milling mining head with the horizontal axis. Before starting the mining, the working platform with the shearer is set at such a distance from the bottom of the shaft so that the organ can make a web at a depth of 0.3 m (maximum – 0.35 m). The slotting takes place by means of the pivoting arm of the mining head. When lowering the work platform, the long bucket conveyor is also lowered. After establishing and spreading the working platform, the slotting phase takes place. During the slotting, the platform rotary ring performs a rotational movement with the working speed. During the rotation of the platform rotating ring the milling mining head makes a toroidal shape with a rectangular cross-section of the width equal to the width of the mining head. After making one cut, the organ is lifted, and the platform rotary ring returns to the starting position. Then, it is necessary to slot the mining head in the new cut; i.e., in a new position towards the axis of the shaft by the value of the mining head web (as shown in Figure 19). During the phase of the excavation and normal mining, the plowshare loader moves behind the mining head and loads the output to the conveyor assembly. The long bucket conveyor haulage the output outside the working platform to the required height resulting from the equipment used in the shaft complex. After making the full shaft bottom layer, the organ returns to the initial position, and the next cut is made with a 0.3 meter depth by leaving the platform with the shearer.

The presented shaft shearer differs from the complexes available on the market as well as those known from the literature. It is characterized by a modular structure with wide modification possibilities, which translates into many variants adapted to different working conditions, needs, and requirements of the user and coexisting in the excavation of the machines and devices.

## 6. SUMMARY

The machine and equipment solutions presented in this article are the result of research carried out at the Department of Mining, Dressing, and Transport Machines. They are innovative solutions that are not currently encountered in Polish mining. Some of them have already been successfully subjected to field testing, while the remaining solutions are currently at the stage of preliminary project preparation (with the implementation of prototypes on this basis). It can be forecasted that, in the near future, several of the solutions presented in the article may be successfully used in Polish underground mining.

## References

- [1] Kotwica K., Gospodarczyk P., Stopka G., Kalukiewicz A.: *The designing process and stand tests of a new solution of a mining head with disc tools of complex motion trajectory for compact rocks mining*, "Quarterly Mechanics and Control" 2010, 29, 3: 119–129.
- [2] Kotwica K., Gospodarczyk P., Stopka G., Puchała B., Słowiński A.: *Wyniki prób poligonowych głowicy urabiającej nowej generacji z narzędziami dyskowymi o złożonej trajektorii ruchu*, "Przegląd Górniczy" 2011: 11: 31–36.
- [3] Kotwica K., Gospodarczyk P., Stopka G.: *A new generation mining head with head with disc tool of complex trajectory*, "Archives of Mining Sciences" 2013, 58, 4: 985–1006.
- [4] Kotwica K., Krauze K., Wydro T.: *Zastosowanie tymczasowej obudowy zmechanizowanej w procesie drążenia wyrobisk korytarzowych*, "Zeszyty Naukowe Politechniki Śląskiej" 2007, 1765, 280: 311–325.
- [5] Krauze K., Bołoz Ł., Wydro T.: *Prototype of temporary mechanized mine roadway support of the dog headings. Theory and technique of coal mining and disaster prevention in deep mines*, in: *Proceedings of international mining conference, Anhui University of Science and Technology, China*, 2014: 538–545.
- [6] Krauze K., Bołoz Ł., Wydro T.: *Urządzenie do montażu lukowej obudowy podatnej w podziemnych wyrobiskach korytarzowych*, Opis zgłoszeniowy wynalazku, PL 412667 A1, "Biuletyn Urzędu Patentowego", 2016: 33.
- [7] Bołoz Ł.: *Unique project of single-cutting head longwall shearer used for thin coal seams exploitation*, "Archives of Mining Sciences" 2013, 58, 4: 1057–1070.

- [8] Krauze K., Bołoz Ł.: *Model jednoorganowego frezującego kombajnu ścianowego*, "Napędy i Sterowanie" 2010, 12: 120–123.
- [9] Kotwica K., Krauze K., Bołoz Ł., Twardak E.: *Wpływ warunków górniczo-geologicznych w drążonym szybie na prace organu urabiającego kombajnu szybowego*, in: III Międzynarodowa Konferencja: *Problemy bezpieczeństwa w budowie i eksploatacji maszyn i urządzeń górnictwa podziemnego*, Wydawnictwo ART. 21, Katowice–Łędziny 2010: 134–146.
- [10] Krauze K., Bołoz Ł., Wydro T., Mucha K.: *Kompleks szybowy nowej generacji*, in: *Mechanizacja, automatyzacja i robotyzacja w górnictwie. T. 2: Problemy eksploatacji i zarządzania w górnictwie podziemnym i odkrywkowym*, red. K. Krauze CBiDGP Łędziny–Kraków 2017: 103–112.
- [11] Krauze K., Bołoz Ł., Wydro T.: *Zmechanizowany frezujący kompleks szybowy*, IV Polski Kongres Górniczy, Kraków 2017: 105–106.

*KRZYSZTOF KRAUZE, prof.  
KRZYSZTOF KOTWICA, prof.  
Department of Mining, Dressing  
and Transport Machines  
Faculty of Mechanical Engineering and Robotics  
AGH University of Science and Technology  
al. Mickiewicza 30, 30-059 Krakow, Poland  
{krauze, kotwica}@agh.edu.pl*