

Analysis of the efficiency of wood pellet production in 2018-2022, on the example of a small capacity company located in southern Poland

ROBERT DURAJ¹, SŁAWOMIR KRZOSEK²

¹ Faculty of Wood Technology, Warsaw University of Life Sciences - SGGW

² Department of Mechanical Processing of Wood, Institute of Wood Science and Furniture, Warsaw University of Life Sciences - SGGW

Abstract: *Analysis of the efficiency of wood pellet production in 2018-2022, on the example of a small capacity company located in southern Poland.* This paper is devoted to analyzing the efficiency of wood pellet production in 2018-2022, on the example of a small production facility located in the southern part of Poland. The first part includes definitions of key terms, i.e. answers to the questions of what a pellet is, what it is used for and what is the main idea of biomass pelletization. In addition to clarifying the most relevant terms, the section also indicates the current importance of the form of fuel under discussion and predictions for its future. The next section presents a description of the pellet production line and production efficiency data. The conclusion, in turn, presents the results of the above analyses, and also indicates the most important problems in the biomass market, which - especially in the last two years - have significantly affected the production market and, consequently, the level of sales.

Keywords: pellets, biomass, efficiency

INTRODUCTION

The changes taking place in the modern world - both those associated with increasing environmental pollution resulting from greenhouse gas emissions and the emerging need for environmentally friendly measures, as well as those resulting from the economic turmoil of recent years (the crisis resulting from the disruption of the supply chain after the Covid-19 pandemic and from the price increase caused by Russia's invasion of Ukraine) - require the search for alternative energy sources. One answer to this demand is certainly the possibility of using biomass, especially one of its forms, pellets. However, the theoretical consideration of the above-mentioned alternative energy sources should begin with definitions of key terms such as biomass and pellet. The former term refers to the biodegradable fraction of products, wastes and residues from agricultural production (including substances of plant and animal origin), forestry and related industries, including fishing and aquaculture, as well as biogases and the biodegradable fraction of industrial and municipal waste [<https://eur-lex.europa.eu>].

Based on the source of origin, the following types of biomass can be distinguished:

- phytomass (plant biomass),
- zoomass (biomass of animals),
- biomass of microorganisms (e.g. plankton).

By state of aggregation we distinguish:

- solid biomass - mainly products of plant origin, including wood and the waste obtained from its processing, or energy obtained from municipal, industrial, organic waste and so-called energy crops grown specifically for this purpose (including common reed, Sakhalin knotweed, Pennsylvania sida and Jerusalem artichoke),

- liquid biomass - mainly biofuels resulting from the chemical processes to which plants are subjected (e.g., corn or rapeseed, alcohols produced from plants) and acting primarily as additives to standard fuels,
- gaseous biomass - decomposition products of organic waste, i.e. biogases consisting primarily of carbon dioxide and methane, used for heat and electricity production, among other purposes [<https://domzogradem.eu/>].

Biomass contains energy that can be utilized for human needs, which is stored in it in the form of solar energy. This utilization involves the burning of biomass or the combustion of its decomposition products, resulting in heat, which in turn can be converted into other types of energy (such as electricity). Several important advantages of biomass can be pointed out. These are primarily:

- the fact that its combustion is more beneficial to the environment than the combustion of fossil fuels due to its lower content of harmful elements (mainly sulfur) than, for example, in coal.
- the relatively constant and homogeneous spatial distribution, reducing transport costs, for example,
- theoretically more favorable balance of carbon dioxide in relation to fossil fuels (part of it is absorbed in photosynthesis) [<https://biznesalert.pl/>].

Biomass is widely used for heating and cooking, and after appropriate conversion - also for the production of electricity in thermal power plants. It is becoming increasingly popular in Poland not only because of the advantages indicated earlier, but also because of legal regulations in the European Union requiring affiliated countries to use it as fuel. The biomass used is produced in Europe, but its insufficient supply makes it necessary to import it from outside the European Union, e.g. from Africa or Asia, which, however, nullifies the assumed pro-environmental benefits (reduced emissions). In recent years, this tendency has further intensified, especially since a large part of the energy source in question was imported from Russia, and after the outbreak of the war this was curtailed. The increasing cost of biomass is also a result of the shortage [<https://biznesalert.pl/>].

Pellet is a solid fuel in the form of pellets in the shape of rolls usually 6-8mm in diameter and up to 30mm in length. Pellet production is carried out by pressing sawdust under high pressure in front of suitable dies. The resulting pellet should have a bulk density in the range of 600-750kg/m³, in addition, it should not have a higher moisture content than 10%. The term pellet comes from the English language (pellets; in Poland, the names pellets, pellets are also used) and means pellets of various shapes, which are made from biomass. It is not a type of fuel, but a form of it (animal feed, animal bedding, fertilizer for horticulture, as well as coal fuels are also offered in this form). Hence, when talking about pellets to be used as fuel for a low-power energy system, it is necessary to provide additional information, e.g. wood pellets, straw pellets, and so on. This most common type of it (fuel) is in the form of cylinders with a diameter not exceeding 25 mm [Cichy].

The aforementioned fuel pellets are made from plant biomass - woody (most often wood of forest trees - chips, shavings, sawdust, wood from special energy crops, bark, waste wood from wood production and processing plants) or (less often) herbaceous (nut shells, sunflower or straw from various cereals). The crushed and dried so-called lignocellulosic particles are subjected to a series of technological operations, the most important of which is the process of densification (pressing) carried out in suitable pelleting installations, i.e. granulators [Cichy]. Wood pellets are the most popular biomass fuel on the market for powering low-power installations, which is due to such properties as: low content of minerals denoted as ash, relatively high calorific value (at the level of inferior coal grades), low content of structural elements (sulfur, nitrogen, chlorine), low content of toxic trace elements (arsenic, cadmium, chromium, copper, nickel, lead, zinc and mercury) [Quiet]. It is mainly used in individual

heating (heating of homes, factories, public buildings) and in district heating (in suitable boiler plants). It is also used in animal husbandry (for example, bedding in horse stables and poultry houses, as well as for pets such as chinchillas and rabbits).

The raw material for the production of wood pellets is wood biomass such as wood chips, shavings, sawdust, wood from special energy crops, bark, waste wood from manufacturing and wood processing plants. Pellets are also produced from nut shells, sunflower seeds and straw [Placko - Wozinska]. The wood that is the main raw material for pellet production is chipped and is about 1 mm thick and up to 3-4 mm long. Unlike particleboard production, specially prepared chips are not required here, but the presence of mineral and metal admixtures is not allowed in the raw material. Depending on the type of this raw material, pellets have different colors of finished pellets and are divided into:

- black (from wood having bark and from wood affected by rot),
- gray (from unbarked wood, pellets have inclusions from bark),
- light (from high quality debarked wood) [<https://technomaszbud.pl/tajemnice-produkcji-pelletu-od-a-do-z-jak-produkowac-pellet>].

The quality of pellet bonding also depends on the raw materials. The natural binder in the pressing process here is the lignin contained in the wood, but it should be remembered that its content in each species varies. Therefore, the more lignin in the wood, the higher the quality of the pellet.

The next important technological factor is the hardness of the wood. The harder it is, the greater the wear and tear on the cutting tools, die and rolls of the pelletizer [<https://technomaszbud.pl/>]. Pellets are an energy source covered by the ENplus certification system in Europe, which determines, for example, what additives can be introduced into the production of the biomass in question or how it is to be packaged. All this is aimed at improving the quality of the fuel, reducing emissions or improving production efficiency.

Additives allowed in pellet production are:

starch,

corn flour,

potato flour,

vegetable oil,

lignin derived from processed or unaltered agricultural products or unmodified economy and forest products.

Keeping a list of additives used and having their specifications is the responsibility of the manufacturer. Additives are allowed in the volume of a maximum of 2% of the total weight of the pellets, whereby:

additives added during the production process = 1.8 in %.

additives added after production (e.g., coating oils) = 0.2 in % [<https://magazynbiomasa.pl/>].

The basic technical parameters of pellets are also specified, such as moisture content (its optimal value is 6-9%) or bulk density (optimal is 650 kg/ m³). In turn, the required dimensions of the pellets are diameter Ø 6 mm ± 1 mm or Ø 8 mm ± 1 mm, and length of 3.15 ≤ X ≤ 40mm (1% above 40mm is allowed) [<https://magazynbiomasa.pl/>].

Biomass pelleting is becoming increasingly popular, and the main reason for this popularity is the fact that pellets (especially wood pellets) represent a convenient for users, relatively cheap and environmentally friendly fuel (its advantages are described in more detail a few pages below). Production of the energy source in question is constantly growing. For example, in 2018 in Europe it was recorded an increase of 9.2%, to more than 20 million tons, in 2021 European Union countries consumed 23.1 million tons, and in 2022 it was expected to

consume 24.3 million tons. However, the introduction of EU regulations related to environmental protection and health and safety rules, as well as the energy crisis caused by the war in Ukraine, have brought problems for producers, which primarily involve a significant increase in costs. The entrepreneurs themselves describe these problems as follows:

The reasons for the plight of the Polish pellet market are to be found in the rising costs of companies. Since the beginning of the year, plants have been subject to a power fee (about 10% of the cost of el. energy), the price of electricity has risen (about 30%) and much more. Less than a year ago, in August 2020, I bought stretch film at the price of PLN 5.20, and today it costs PLN 11, so it has become 100% more expensive. Plastic bags - by about 30-40%. The cost of buying sawdust - I don't think I'm exaggerating when I say that it has increased by about 50 or even 60%. On top of that there are labor costs [Klimczak]. The market is at a delicate moment, as its development depends on environmental political decisions, and Polish and EU energy policies are not entirely consistent. EU funds and other climate changes, sudden price increases and inflation in recent months due to COVID-19, as well as public hopes and expectations play an important role [Klimczak]. Both statements are from June 2021, so they do not yet take into account another cause of the crisis, the war in Ukraine. This one paradoxically affected the market in two ways - on the one hand, it contributed in the aforementioned increase in costs, and on the other, it intensified the demand for pellets.

However, the above-mentioned reasons for halting the growth of pelletized biomass production will not change the overall trends and popularity of the energy source in question. It is therefore necessary to take a closer look at the reasons why pellets are so valued by both industrial consumers and individual users. Several such fundamental reasons can be identified:

- the opportunity to use what was previously considered often unnecessary waste - especially in the wood industry, whose representatives increasingly choose to use sawdust, shavings, wood chips or branches to produce pellets. Its sale provides additional income, and use in their own heating plants - additional savings [Placko - Wozinska],
- the fact that the production of the energy source in question does not require special preparation of the raw material, but only chipping the wood into pieces of max. 5-6 mm in size and drying it under appropriate conditions [Placko - Wozinska]. According to the Jagiellonian Institute's expert on supply chains and co-author of the report "Biomass from sustainable sources - a strategic option in the challenge of Poland's decarbonization": (...) the benefits of using large-scale, sustainable biomass in Poland's energy transition stem from the fact that it can be converted to this fuel very quickly. Most existing plants can be quickly adapted to operate on biomass, which also preserves many jobs [„Biomasa w ciepłownictwie i energetyce” 2022],
- pro-environmental measures, including those aimed at reducing carbon dioxide emissions, with which the decarbonization of the Polish power sector is linked. Poland is the third among EU countries in terms of the level of greenhouse gas emissions (in 2017: 80 MtCO_{2e}, or more than 800 g CO_{2e} for every euro of GDP). One of the most important topics for the economy is therefore to take the optimal path of decarbonization. According to the report "Sustainably sourced biomass - a strategic option in Poland's decarbonization challenge," prepared by the US Industrial Pellet Association (USIPA) together with the Jagiellonian Institute, a direction that can facilitate an effective transition away from coal use in power

and heating is to build an energy mix based on biomass, among other things. Such a transformation at the same time can become an opportunity for: investment, new jobs, lowering generation costs, reducing energy and heat prices, reducing emissions or improving the environment [<https://magazynbiomasa.pl/>]. The environmental friendliness of pellets is also evidenced by the already mentioned low content of structural elements (sulfur, nitrogen, chlorine) and low content of toxic trace elements (arsenic, cadmium, chromium, copper, nickel, lead, zinc and mercury),

- the peculiar versatility and flexibility of biomass fuel, which is emphasized by the aforementioned expert Maciej Mierzwiński: The "flexibility" of this fuel is also an important issue. We can freely regulate the amount of energy produced from it and respond to the real needs arising in the system [<https://magazynbiomasa.pl/>].
- the fact that pellets are a convenient fuel for users and relatively inexpensive. Its cost-effectiveness is due to several factors already pointed out in this paper, such as: the possibility of using the entirety of a given raw material, including its waste, the relatively inexpensive and easy installation of appropriate production equipment, the convenience of the fact that the components needed for production are "on site", which reduces, for example, transportation costs, or the relatively easy packability of the resulting product,
- the comfort of the individual user resulting from the fact that only a small amount of ash and negligible amounts of carbon dioxide are produced during the combustion process, that it does not contain harmful substances and does not emit unpleasant odors, and that pellet stoves are fully automated and easy to operate,
- relatively high calorific value (at the level of inferior grades of coal), which can reach the limits of 4.6-5 kWh/kg and 16-20 MJ/kg, which is not much lower than those of the so-called eco-pea (this one remains at about 22-24 MJ/kg). The calorific value of 2 kg of this biomass is equal to that of 1 liter of fuel oil. This means high efficiency, which should contribute to greater domestic savings [<https://captainpellet.pl/>].

Another important (if not the most important) advantage of pellets until recently was their relatively low cost. Although still - in theoretical terms - this cost is an advantage of using the energy source in question, it should be added that in recent years - mainly as a result of market destabilization caused by Russia's invasion of Ukraine and high inflation - there has been a destabilization of the market, resulting in a sharp increase in biomass prices. Toscana Pellet CEO Andrzej Kostyk explains this phenomenon as follows: "The situation in eastern Europe, the global increase in energy commodity prices, general market uncertainty and inflation prompted a large group of producers to take advantage of this period and raise prices to abstract levels in weekly cycles. As a result, this artificially screwed up demand, which in turn was the cause of a temporary shortage of goods on the market. Fear of the unknown caused wholesalers to fill warehouses and retailers to buy beyond their needs in a panic. The culmination of this hyperbolic growth came in mid-November, which meant saturation beyond measure, and this, along with the warm winter, resulted in a drastic reduction in demand" [<https://magazynbiomasa.pl/>].

Poland as a pellet producer is compared with Belgium, Finland and Hungary in terms of production volume. In 2017-2018, for example, Poland's pellet production increased by 18%, where production growth in Europe was recorded at 10%. The largest pellet producers are Germany, Russia, Sweden, Latvia and France. The individual figures are well shown in Figure 1.

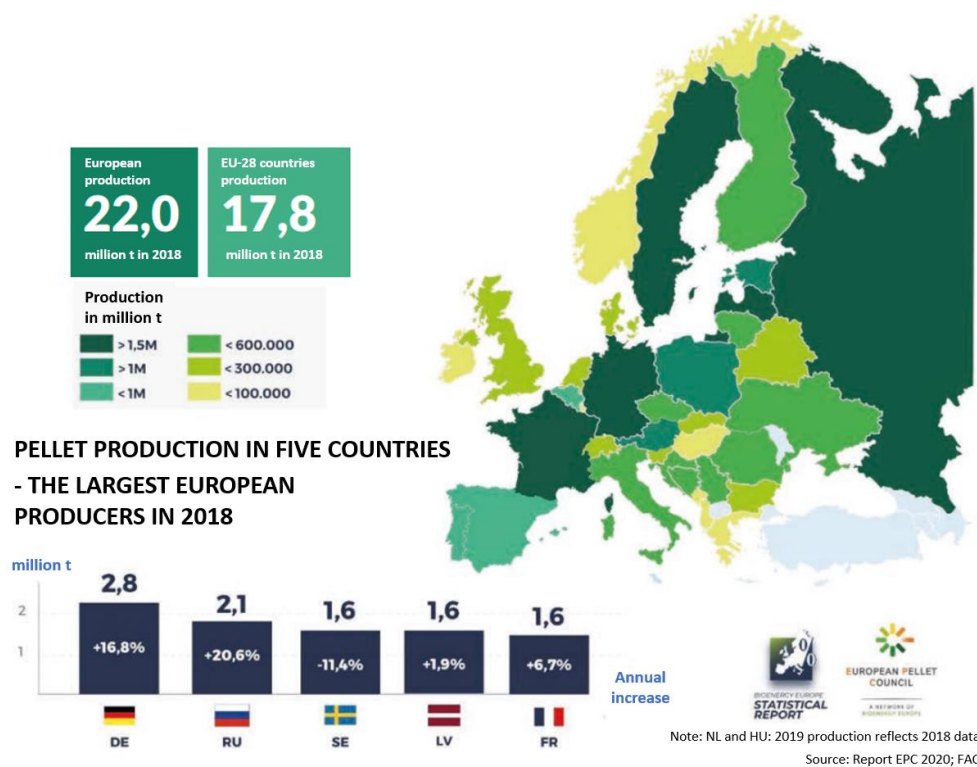

Source: <https://magazynebiomasa.pl/pellet-drzewny-w-polsce-to-pierwszy-taki-raport-na-rynku/>

Figure 1. Wood pellet production in Europe in 2019

Figure 1 also shows the increase in production in 2019 compared to 2018, with Germany seeing a 16.8% increase in production, Russia a 20.6% increase and again Sweden an 11.4% decrease in production, in addition Latvia increased its pellet production by 1.9% and France by 6.7%. Putting together Poland's production growth of 18%, Poland performs very well and achieves production of 1 million tons per year. Global production over the same period increased by 12%, with non-EU countries and South America posting large production increases of 37% and 21%, respectively.

Pellet production and properties

The wood pellet market in Poland has gradually changed over the course of each year. In 2018, when the company started production, it quickly became apparent that pellets were plentiful in the area (in the Żywiec region), so that prices were quite low, and the raw material itself held a steady price. In the following years, the situation began to change: in fact, the demand for pellets grew steadily, and more and more customers set up corresponding boilers. By the end of 2019, the company no longer had a problem selling the commodity in question. However, the following year in late autumn and winter pellets were already in short supply. The next year looked very similar. In 2022, when the global energy problem appeared, the prices of all fuels began to skyrocket very quickly. It is worth tracing the reasons for the phenomenon indicated above. Everything had already started to change in 2021, when wood prices increased by about 60% compared to the previous year, and in the following year they still skyrocketed up to about 100% compared to 2020. Such large increases in the price of wood raw material were reflected in all sortiments, including wood waste, i.e. sawdust, chips,

woodchips (biomass). This happened because some companies producing, for example, wood-based panels, instead of using expensive assortments (S2A) for their products, used more and more of the cheaper raw material, which is precisely sawdust, shavings or wood chips. Due to the growing demand for biomass, prices for this group of raw materials have skyrocketed. The production of wood pellets is mainly based on the raw material of the smallest fraction, the most common being sawdust and wood chips. Wood chips are produced when cutting both dry and wet wood, but in practice the wood is cut after drying the raw material beforehand, so that the waste in the form of chips is dry. These chips after cutting dry wood are practically ready for pellet production, so such pellet production does not require drying, and this significantly reduces the cost of production and there is no need to purchase an expensive biomass drying line. The second fine material used in pellet production is sawdust. They are mainly formed when wood is cut with circular, band and gang saws. Much of it is produced in sawmills when sawing wet wood on vertical frame sawmills or circular saws. Sawdust is thus fine and does not require additional grinding, which consumes a lot of energy. The raw material, on the other hand, is wet, so it requires an additional drying process, which raises production costs. A line for producing pellets from dry wood chips is shown in the figure below (Fig. 2):

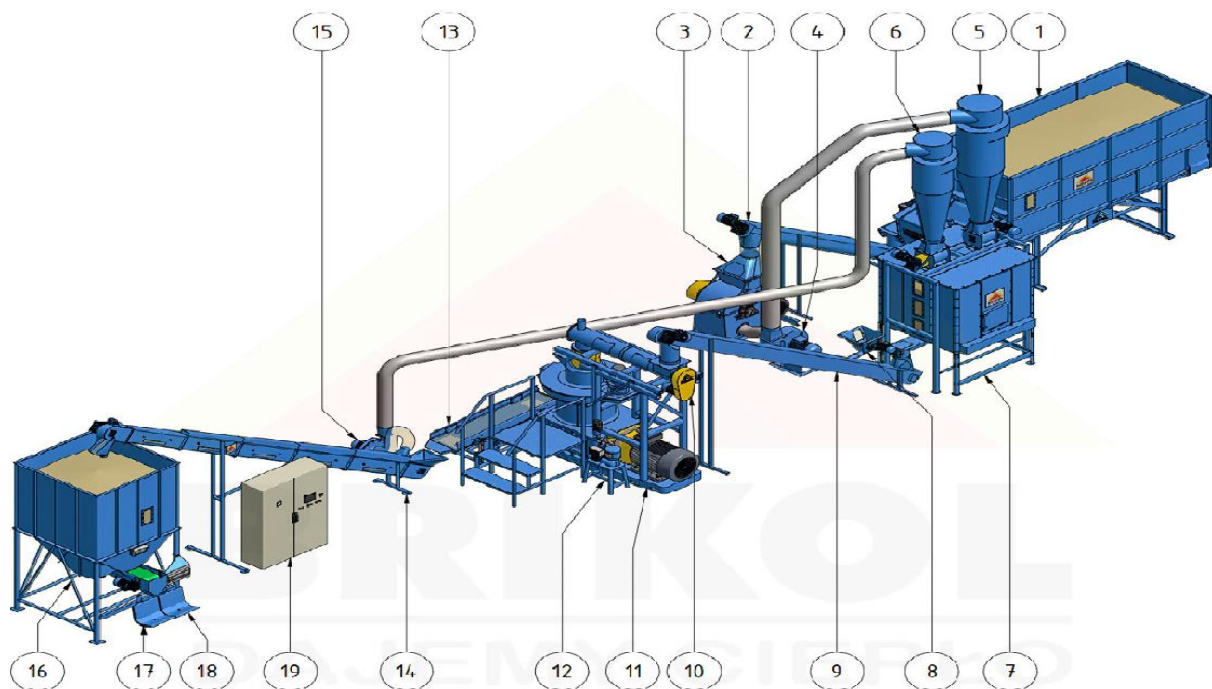

Source: <https://brikol.pl/konfigurator-linii>

Figure 2: Dry biomass pellet production line. Description of individual devices in the line: 1. Charging hopper. 2. Auger feeder. 3. flail mill. 4. Fan. 5. Cyclone. 6. Separation cyclone. 7. Dust extraction. 8. Binder dispenser. 9. Blade feeder. 10. Conditioner. 11. Granulator. 12. water dispenser. 13. Pellet sifter. 14. Conveyor feeder. 15. Extraction fan. 16. Finished product tank with cooling. 17. Packaging system. 18. Sealing machine. 19. Control cabinet.

In this variant of the line, the purchase of 1 ton of dry wood chips produces about 1 ton of pellets. There may be a slight difference in weight, as the granulator in continuous operation reaches a temperature of about 90°C, so some of the moisture from the sawdust will evaporate

during pelleting. Dry sawdust has a moisture content of about 4-15%, and the resulting pellets should have up to 10% moisture content, so depending on the input moisture content of the sawdust, water dosage is selected to make up for the loss due to evaporation during pelleting.

Analyzing the pelleting process, it can be seen that no glue of any kind is added during pellet production. This is not environmentally friendly, and besides, in the process of burning pellets in boilers, compounds can be formed that will reduce the life of the boiler. By definition, pellets should be an ecological fuel, so any synthetic additives are not advisable. When producing it, natural binders should therefore be used. An example of such a binder is the lignin contained in the wood shavings themselves, which is a natural glue that plasticizes under the influence of moisture and temperature. In addition, the natural binders used can be flour additives, bran (wheat, rye, barley), oats and corn. Such additives facilitate the production process, but should not be used in more than 1-2%, as they reduce the calorific value of the pellets. During production, the chips in the codifier are heated and mixed with moisture. The next step is to give the pellets the right diameter and length. For such a diameter is responsible for the die, which has the appropriate holes (usually 6 or 8 mm) and the previously prepared raw material is pressed into them.

An example of a wet biomass pellet production line is shown in Figure 3.

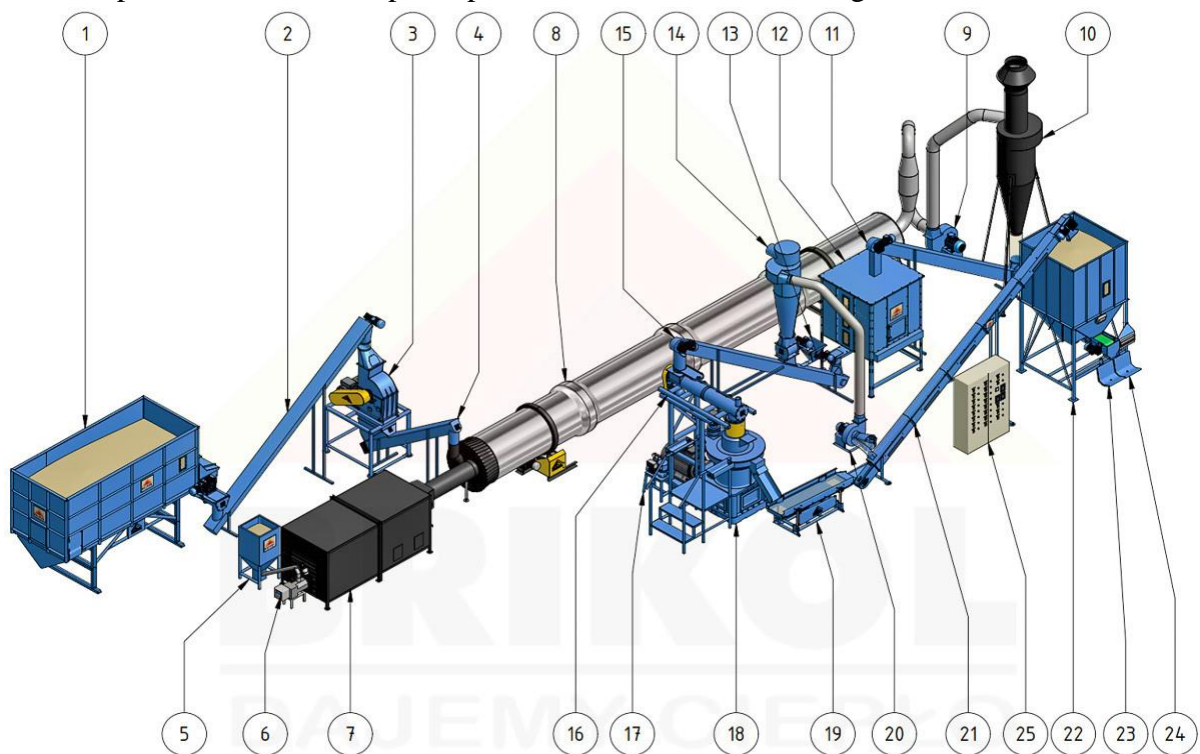



Source: <https://brikol.pl/konfigurator-linii>

Figure 3: Wet biomass pellet production line. Description of individual equipment in the line: 1.Feed hopper. 2.Screw feeder. 3.Beater mill. 4.Screw feeder. 5.Pellet hopper. 6.Dryer furnace. 7. heat buffer. 8. Drum dryer. 9. fan. 10. Cyclone. 11.Screw feeder. 12.Buffer tank. 13.Binder dispenser. 14.Separation cyclone. 15.Paddle feeder. 16.Conditioner. 17.Water dispenser. 18. granulator. 19. Pellet sifter. 20. Extraction fan. 21. Conveying and cooling feeder. 22. Finished pellet tank with Cooling. 23. Packaging system. 24. Sealing machine. 25. Control cabinet.

In turn, a cutter is responsible for the length of the pellets, which is set so that the pellets are 15-25mm long. After the pellet is pressed through the die, it has the right shape, and by acting with high pressure it acquires a high temperature. The next stage is the cooling of the pellets, in which the raw material hardens, and as the temperature drops, some of the moisture is taken away, so that it ultimately has less moisture. Speaking of the properties of pellets, it should be noted that there are now standards that define the standards of their quality and are certified: ENplus® and DINplus (the logo always and only appears with a number). Each such certified pellet has a corresponding marking or logo on the bag.

Basic information on the two certificates in question, i.e. their purpose, scope and origin, is provided in Table 1.

Table 1. Types of pellet certificates

Sign		
Standard	ENplus (klass: A1, A2, B) Quality requirements acc. to: EN ISO 17225-2	DINplus (klass A1) Quality requirements acc. to: EN ISO 17225-2
Destiny	ENplus – intended for wood pellets for heating purposes	DINplus – intended for wood pellets for central heating boilers
Introduction	Valid from: 2010 year	Valid from 2002 year
Owner	Mark owner: European Pellet Council (EPC)	Mark owner DIN CERTCO GmbH

Source: <http://polskaradapelletu.org/o-peliecie/>

Undoubtedly, a great influence on the quality of pellets is the wood raw material used in production. All types of this raw material can be used in accordance with ISO 17225-2, and the range is defined in the sheet standard EN ISO 17225-1. The exact parameters and data for each quality class of pellets are shown below (Table 2.). Wood pellets for commercial and domestic use according to ENplus® standard have 3 quality classes:

- property class A1 - is the highest quality pellet for use in boilers and stoves heating households. The combustion of a pellet in this class is characterized by low ash and nitrogen formation and high combustion parameters,
- Property class A2 - includes pellets for use in larger installations, among other things, due to the higher amount of ash and nitrogen formed,
- Property class B - pellets of this class can be produced from chemically untreated usable wood, as long as they do not contain heavy metals and organochlorine compounds in amounts greater than the values in typical original material or greater than the values typical for the country of origin [<http://polskaradapelletu.org>].

Table 2. Exact quality parameters for individual pellet quality classes

PARAMETER	UNIT	ENPLUS A1	ENPLUS A2	EN B	DINPLUS
Diameter	[mm]	6 or 8 ± 1	6 or 8 ± 1	6 or 8 ± 1	6 or 8 ± 1
Length	[mm]	3,15 ≤ L ≤ 4*	3,15 ≤ L ≤ 4*	3,15 ≤ L ≤ 4*	3,15 ≤ L ≤ 4*
Density	[kg/m ³]	600 ≤ density ≤ 750	600 ≤ density ≤ 750	600 ≤ density ≤ 750	600 ≤ density ≤ 750
Calorific value	[%]	≥ 16.5	≥ 16.5	≥ 16.5	≥ 18
Humidity	[%]	≤ 10	≤ 10	≤ 10	≤ 10
Dust and sifting	[%]	≤ 1 loose pellets (≤ 0,5 bags to 30kg)	≤ 1 loose pellets (≤ 0,5 bags to 30kg)	≤ 1 loose pellets (≤ 0,5 bags to 30kg)	≤ 1 big bags and collective packaging (≤ 0,5 bags to 20kg)
Mechanical strength	[%]	≥ 98	≥ 97,5	≥ 97,5	≥ 97,5
Ash content	[%]	≤ 0,7	≤ 1,2	≤ 2,0	≤ 0,7
Ash melting point	[°c]	≥ 1200	≥ 1200	≥ 1100	≥ 1200
Calorific value	[KWh/kg]	≥ 4,6	≥ 4,6	≥ 4,6	≥ 16,5 Mj/kg ≥ 4,6 kwh/kg
Value of additives	[%]	≤ 2	≤ 2	≤ 2	≤ 2

Source: <http://polskaradapelletu.org/o-pellicie/>

MATERIAL AND METHOD

In order to calculate how profitable the production of pellets is, it is necessary to know all unit costs of given materials, electricity. It is also necessary to calculate what the production costs are for making 1 ton of pellets. To calculate the profit from production, it is also necessary to know the amount for which the pellets were sold. I obtained all the cost values for the different years covered by the analysis as well as the selling price from a friendly company, which is a small producer based in the Żywiec region. This makes it possible to calculate how profit developed in each year. Tab. 3 shows the unit costs.

Table 3. List of unit values of production costs.

Costs/year	2018	2019	2020	2021	2022
Chips	20zł/m ³	20zł/m ³	20zł/m ³	20zł/m ³	50zł/m ³
Man-hour	18zł/1h	20zł/1h	21zł/1h	23zł/1h	27zł/1h
Electricity	540zł/1MWh	540zł/1MWh	560zł/1MWh	850zł/1MWh	1200zł/1MWh
Diesel	3.65zł/1l	3.96zł/1l	4.20zł/1l	4.50zł/1l	6.60zł/1l
Gas	43zł/bottle	60zł/bottle	65zł/bottle	80zł/bottle	80zł/bottle
Bran	650zł/ton	650zł/ton	600zł/ton	700zł/ton	700zł/ton
Pallets	20zł/pcs	20zł/pcs	20zł/pcs	20zł/pcs	50zł/pcs
Pelletbags	31gr/pcs	31gr/pcs	31gr/pcs	48gr/pcs	55gr/pcs
Other	40zł/ton	42zł/ton	42zł/ton	44zł/ton	50zł/ton

Other costs include the following:

- New dies, grinding of used ones
- New rollers, milling of used ones
- Grease for lubricating rollers, main shaft and all bearings in the line
- Oil for gearboxes
- Operation of the car
- Forklift operation
- Stretch film for packing the finished product

We calculate the individual costs of chips, man-hours, diesel, electricity and pellet bags from the formula:

$$K = A * B$$

Where:

K = cost

A = value of a given cost

B = quantity of a given cost

List of individual cost quantities.

- to produce 1 ton of pellets requires 13.5 m³ of chips
- production time for 1 ton of pellets is a total of 8h (with 4h employee on the line and 4h driver delivering chips)
- the line during production consumes about 18KW of electricity for 1 hour of production
- for the delivery of 1 ton of raw material, diesel fuel consumption was 8l
- 67 bags are needed to pack pellets
- the forklift burned an average of 1 cylinder of gas per 10 tons of pellets produced (it was used to transport pellets from the production hall to the warehouse and then loading on the truck).
- Consumption of bran is at the level of 20kg per 1 ton of pellets.
- finished pellets packed in bags were stacked on a pallet with 67 bags.

The calculated total costs per 1 ton of pellets are shown in the table below (Tab. 4).

Table 4. List of costs per ton of pellets.

Costs/year	2018	2019	2020	2021	2022
Chips	270zł	270zł	270zł	270zł	67zł
Man-hour	144zł	160zł	168zł	184zł	216zł
Electricity	39zł	39zł	40zł	61zł	86zł
Diesel	29zł	32zł	34zł	36zł	53zł
Gas	4zł	6zł	7zł	8zł	8zł
Bran	13zł	13zł	12zł	14zł	14zł
Pallets	20zł	20zł	20zł	20zł	50zł
Pelletbags	21zł	21zł	21zł	32zł	37zł
Other	40zł	42zł	42zł	44zł	50zł
Total	580zł	603zł	614zł	669zł	1189zł
Costincrease	0%	↑3,97%	↑5,86%	↑15,34%	↑105%

To calculate the production profit, I obtained the average price at which the company sold pellets (Tab. 5).

Table 5. List of pellet sales price by year.

Material/year	2018	2019	2020	2021	2022
pellets	650zł	680zł	700zł	770zł	1650zł
Priceincrease	0%	↑4,62%	↑7,69%	↑18,46%	↑153,85%

To calculate the profit, I used the following formula:

$$Z = (S - K) * I$$

Where:

Z- profit

S- average selling price of 1 ton of pellets

K- cost per 1 ton of pellets

I- quantity of pellets produced in a year

RESULTS AND DISCUSSION

Assuming production of 500 tons of finished pellets, profits in each year were (Tab. 6):

Table 6. List of profits from pellet production.

Profit/year	2018	2019	2020	2021	2022
Profit	35 000zł	38 500zł	43 000zł	50 500zł	233 000zł
Profit growth	0%	↑10%	↑22,86%	↑44,29%	↑565,71%

In the presented Table 6, you can see the increase in profit in subsequent years. When the company started pellet production in 2018 it was a profit of 35t, but 4 years later the profit was already 233t. The company in each of the individual years kept the production at the same level, i.e. 500t of finished pellets per year. However, the market demand for pellets grew steadily, so the price of pellets gradually increased. In addition, in 2022, by the global energy problem, prices went up sharply. The price of pellets at the end of 2022 reached as much as PLN 3,000 per ton, this is a very large increase in price compared to the previous year, where it was about PLN 1,200. There was a severe shortage of pellets on the market and customers needed pellets for home heating. In practice, it looked like the company did not take large orders for pellets, and sold the pellets it produced to retail customers in smaller quantities so that everyone would have something to heat with.

CONCLUSIONS

Analyzing the results, one can observe a continuous increase in production costs between 2018 and 2022. In 2019, the cost increase was 3.97%, in 2020 it was already up to 5.86%, in the following year it was 15.34% and the largest increase in production costs occurred in 2022, where it was as high as 105% compared to 2018. Such large increases in costs led to a continuous increase in the price of pellets. In 2019, the increase in the price of pellets was 4.62%, in 2020 the price increased by 7.69%, the following year by 18.46% and in 2022 the price increase reached as much as 153.85% compared to 2018. Comparing costs with the selling price and the amount of pellet production, it is possible to calculate the profit in each year. In 2019 the profit increase was 10%, in 2020 the profit increased by 22.86%, in the following year it was an increase to a value of 44.29% and in 2022 the price increase compared to 2018 was as high as 565.71%. In 2022, profit growth was very high, mainly caused by the lack of pellets on the market.

SUMMARY

Pellets are therefore a very important form of fuel in the energy market, and especially in the market for materials used for heating in domestic installations. This type of biomass undoubtedly represents an ecological and convenient source of energy, a source that is also produced through a relatively easy production process. According to the EU Biofuels 2018 report prepared by the European Commission, we are ranked fifth among pellet-producing

countries in Europe. The annual scope of this production is about 900,000 thousand tons in our country[<http://polskaradapelletu.org>].

It is worth adding that the increase in prices, and the consequent collapse in the market for the sale of the raw material in question, was caused not only by nervous reactions of consumers, but also by the fact that the strategic suppliers of raw material for pellet production, namely Ukraine, Belarus and Russia, stopped supplying it to Western Europe (as a result of the war), and these countries were responsible for the production of about 3.5 million tons of pellets in 2021, which accounted for 30% of total imports. For comparison, in 2019 in Europe, Germany was the largest pellet producer with production of 2.8million tons per year, the next large pellet producer is Russia with 2.1 million tons per year. Sweden is next, with production of 1.6 million tons per year, and France, which produces a similar amount of pellets to Sweden.

This does not change the fact that pellets are a reasonable and effective alternative to other energy sources for the future. The use of this type of biomass makes it possible to effectively combat the phenomena of high carbon dioxide emissions and smog, which affect all Poles. It also allows full use of raw materials - for it is worth adding that producers can make use of more than just waste materials such as wood - even the ash that remains from the combustion of pellets can be used as a fertilizer to fertilize the soil.

REFERENCES

1. CICHY W. J., *Sieć Badawcza Łukasiewicz – Instytut Technologii Drewna, Poznań*, Pellet drzewny – nowoczesny nośnik czystej energii, dostępne w Internecie: <https://magazynbiomasa.pl/pellet-drzewny-nowoczesny-nosnik-czystej-energii-odnawialnej/>
2. <https://magazynbiomasa.pl/ceny-pelletu-czyli-o-kosztownej-lekcji-dla-calej-branzy/>
3. <https://domzogrodem.eu/biomasa.html>
4. <https://biznesalert.pl/pie-tygodnik-gospodarczy-europa-biomasa/>
5. *Kilka słów o kaloryczności pelletu*, dostępne w Internecie: <https://captainpellet.pl/slow-kilka-o-kalorycznosci-pelletu/>
6. *Pellet od A do Z. Wszystko, co musisz wiedzieć, w pigułce*, dostępne w Internecie: <https://magazynbiomasa.pl/pellet-od-a-do-z-wszystko-co-musisz-wiedziec-w-pigulce/>
7. KLIMCZAK B.: *Produkcja pelletu drzewnego wraca do korzeni*, dostępne w Internecie: <https://magazynbiomasa.pl/produkcja-pelletu-drzewnego-wraca-do-korzeni-sprawdz/>
8. PLACKO – WOZIŃSKA K.: *Surowiec stanowi o jakości produktu*, [w:] „Biomasa. Magazyn dla profesjonalistów”, 2022, nr 8, s. 30-32.
9. Opracowanie redakcyjne na podstawie ww. raportu: *Cel – (nie tylko) dekarbonizacja polskiej energetyki*, [w:] „Biomasa w ciepłownictwie i energetyce”, 2022, nr 1, s. 24. <https://magazynbiomasa.pl/dekarbonizacja-polskiej-energetyki-to-nie-jest-jedyny-cel/>
10. *O peliecie*, dostępne w Internecie: <http://polskaradapelletu.org/o-peliecie/>
11. *Tajemnice produkcji pelletu od A do Z. Jak produkować pellet*, dostępne w Internecie: <https://technomaszbud.pl/tajemnice-produkcji-pelletu-od-a-do-z-jak-produkowac-pellet>
12. *Rozporządzenie Komisji (UE) nr 651/2014 z dnia 17 czerwca 2014 r. uznające niektóre rodzaje pomocy za zgodne z rynkiem wewnętrznym w zastosowaniu art. 107 i*

108 Traktatu.(CELEX: 32014R0651). <https://eur-lex.europa.eu/legal-content/PL/TXT/PDF/?uri=CELEX:32014R0651&from=CS>

13. <https://magazynbiomasa.pl/pellet-drzewny-w-polsce-to-pierwszy-taki-raport-na-ryнку/>
14. <https://brikol.pl/konfigurator-linii>
15. <http://polskaradapelletu.org/o-pellicie/>

Streszczenie: *Analiza efektywności produkcji peletu drzewnego w latach 2018 – 2022 na przykładzie małego zakładu produkcyjnego położonego w południowej Polsce.* Artykuł jest poświęcony analizie efektywności produkcji peletu drzewnego na przykładzie małego zakładu produkcyjnego zlokalizowanego w południowej Polsce. W pierwszej części artykułu wyjaśniono czym jest pelet, jak i z czego może produkowany. Szerzej zaprezentowano wymagania stawiane peletowi z drewna oraz technologii jego produkcji. Jest to obecnie ważny rodzaj ekologicznego paliwa z dobrymi perspektywami na przyszłość. W konkluzji przedstawiono rezultaty analizy efektywności produkcji peletu drzewnego w kilku ostatnich latach na przykładzie małej firmy oraz najważniejsze problemy rynku biomasy, z uwzględnieniem zmian kosztów produkcji i wielkości sprzedaży.

Corresponding Author:

Sławomir Krzosek
Department of Mechanical Processing of Wood,
Institute of Wood Science and Furniture,
Warsaw University of Life Sciences – SGGW, Poland
159 Nowoursynowska Street
02- 787 Warszawa, Poland
Slawomir_krzosek@sggw.edu .pl