

## On the efficient use of a low temperature heat source by the organic Rankine cycle

DARIUSZ MIKIELEWICZ<sup>1,2\*</sup>  
JAROSŁAW MIKIELEWICZ<sup>2</sup>

<sup>1</sup> The Szewalski Institute of Fluid-Flow Machinery, Polish Academy of Sciences, Fiszerza 14, 80-231 Gdańsk, Poland

<sup>2</sup> Gdańsk University of Technology, Faculty of Mechanical Engineering, Narutowicza 11/12, 80-233 Gdańsk, Poland

**Abstract** The evaporation temperature is regarded as one of the major parameters influencing the organic Rankine cycle (ORC) efficiency. Majority of contributions in literature for ORC cycle analyses treat the heat source as if it had an infinite heat capacity. Such analyses are not valuable as the resulting temperature drops of the heat source needs to be small. That leads to the fact that the heat source is not well explored and in the case of waste heat utilization it can prove the poor economics of the ORC. In the present study cooperation of the ORC cycle with the heat source available as a single phase or phase changing fluids is considered. The analytical heat balance models have been developed, which enable in a simple way calculation of heating fluid temperature variation as well as the ratio of flow rates of heating and working fluids in ORC cycle. The developed analytical expressions enable also calculation of the outlet temperature of the heating fluid.

**Keywords:** Organic Rankine Cycle; Heat supply; Energy efficiency

### Nomenclature

$c_p$  – specific heat  
 $h$  – enthalpy

---

\*Corresponding Author. E-mail: Dariusz.Mikielewicz@pg.gda.pl

$LMTD$	–	logarithmic mean temperature difference
$\dot{m}$	–	mass flowrate
$p$	–	pressure
$T$	–	temperature
$\Delta T_{min}$	–	pinch point temperature difference

### Subscripts

$w$	–	heating fluid
$vl$	–	vapour-liquid
1, 2...	–	states in ORC

## 1 Introduction

Considerable quantities of low-temperature thermal energy are available from natural sources (solar, geothermal, biomass) and industrial processes in the form of waste heat (power plants, chemical plants, etc.). Conversion of such energy into mechanical energy and subsequently to electricity is considered nowadays as a challenge and presents great opportunities. One of the branches of methods which can be used to achieve such conversion include implementation of the vapor Clausius-Rankine cycle with organic substance as working fluid, the so called organic Rankine cycle (ORC).

The heat source providing thermal energy to the organic Rankine cycle may usually be in the form of hot exhaust gas or hot liquid flows. In some cases we may have at our disposal a phase changing fluid which comes for example from the technological or geothermal vapor, which is condensing whilst supplying heat to the ORC evaporator, Mikielwicz (2011) [1]. The characteristic feature of the single phase fluid heat source is that its temperature decreases when heat is extracted. In case where there is a small difference between the heat source temperature and the ORC working fluid there can arise some kind of difficulty in heating and evaporating of the working fluid. During such process the requirement for existence of the minimum temperature difference between heating fluid and working fluid, the so called ‘pinch temperature’ restricts the reduction of the available heat source temperature to the demanded level, contributing to the ineffective use of the heat source. That minimum temperature difference between the two media is usually assumed as 5 K. The attempt to utilize the heat source to the full extent, revealed in the significant reduction of its temperature, leads to lower evaporation temperatures of the working fluid in the ORC system, thus contributing to substantial reduction of thermal efficiency of ORC. The evaporation temperature is regarded as one of the major pa-

rameters influencing the ORC cycle efficiency. Majority of contributions in literature for ORC cycle analyses treat the heat source as if it had an infinite heat capacity. Such analyses are not valuable as the resulting temperature drops of the heat source need to be small. That leads to the fact that the heat source is not well exploited and in the case of waste heat utilization it can prove the poor economics of the ORC.

In the present study cooperation of the ORC cycle with the heat source available as a single phase or phase changing fluids is considered. The analytical models have been developed, which enable in a simple way calculation of heating fluid temperature variation as well as the ratio of flow rates of heating and working fluids in ORC cycle. The developed analytical expressions enable also calculation of the outlet temperature of the heating fluid.

## 2 Calculation of heat source temperature drop in organic Rankine cycle

The simple organic Rankine cycle is considered, consisting namely of the evaporator, turbine, condenser and circulation pump, Fig. 1. In case of so called 'dry' fluid, i.e., a fluid featuring a positive slope of the vapor saturation line in temperature – entropy diagram, the internal regeneration of the ORC cycle could also be considered, Fig. 2. It is assumed that the working fluid is in the state of saturated liquid at the outlet of the condenser. Its pressure is then raised by the pump to reach evaporation pressure. Subsequently the working fluid is heated reaching evaporation temperature and then is totally evaporated to reach the vapour saturation state. Next, the hot saturated vapour expands in the turbine performing the useful work.

### 2.1 Heat supply to the ORC cycle by hot single phase fluid

The most common way of providing heat to the ORC installation is by means of the hot single-phase fluid. Such situation is schematically shown in Fig. 3. In the considered case it is required that throughout the entire heating process there is preserved the minimum temperature difference,  $\Delta T_{min}$ , between the source temperature and temperature of working fluid, i.e., the so called pinch point temperature difference.

In order to develop a relationship between the heat source temperature

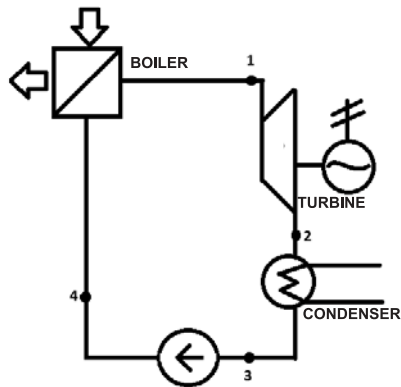

Figure 1. Schematic of the wet ORC cycle without regeneration.

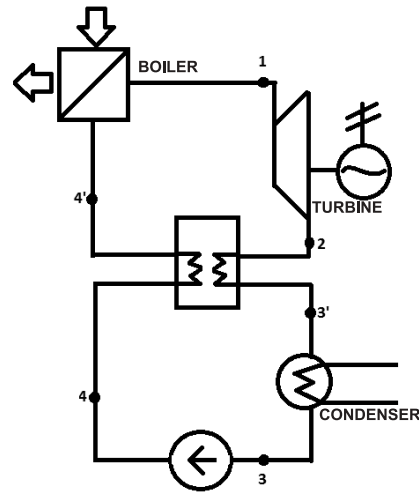

Figure 2. Schematic of the dry ORC cycle with regeneration.

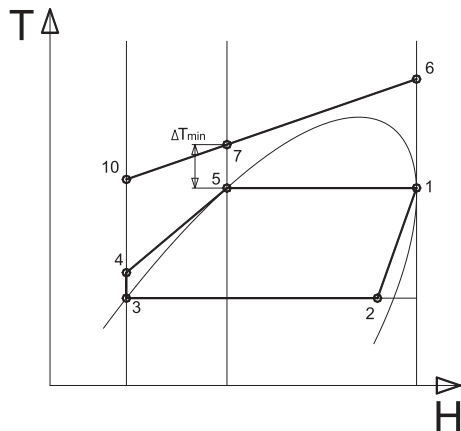

Figure 3. Schematic of heat supply to the ORC installation by means of the single phase fluid,  $H = mh$ .

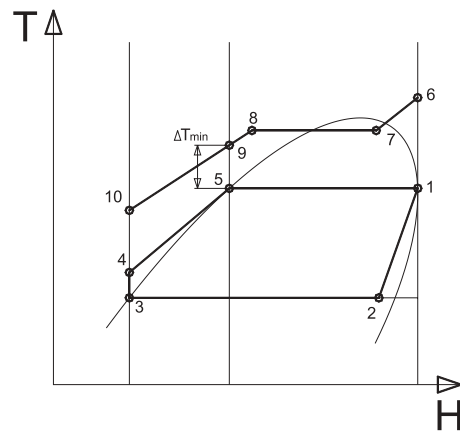

Figure 4. A schematic of heat supply to the ORC cycle by means of the fluid changing phase,  $H = mh$ .

change and the amount of heat supplied to the working fluid we apply the heat balance to the evaporator. In such case where temperature of the working fluid raises from the state 4 to state 1 due to the change of heat source temperature from state 6 to the final temperature of state 10, we

obtain

$$\dot{m}_{ORC}(h_1 - h_4) = \dot{m}_w(h_6 - h_{10}) . \quad (1)$$

The transition from enthalpy  $h_4$  to enthalpy  $h_1$  of the working fluid in ORC cycle consists first of the heating process of the ORC working fluid up to evaporation temperature  $T_1$  and then its subsequent evaporation, hence enthalpy  $h_1$  can be written as

$$h_1 = h_4 + C_{pORC}(T_1 - T_4) + h_{lv}(T_1) . \quad (2)$$

Similarly, enthalpy  $h_{10}$  can be written as

$$h_{10} = h_6 - C_{pw}(T_6 - T_{10}) . \quad (3)$$

In Eqs. (2) and (3) specific heat  $C_{pORC}$  is regarded as a mean value in the temperature range from  $T_4$  to  $T_1$ , whereas that for the heat source,  $C_{pw}$ , is a mean value in the temperature range from  $T_6$  to  $T_{10}$ . Such kind of approximation is sufficient in case of water or exhaust gases considered as heat sources.

Substitution of Eqs.(2) and (3) into (1) gives

$$\dot{m}_{ORC}[C_{pORC}(T_1 - T_4) + h_{lv}(T_1)] = \dot{m}_w C_{pw}(T_6 - T_{10}) . \quad (4)$$

In Eq. (4) unknown are two quantities, namely the temperature of heating fluid at outlet  $T_{10}$  and the ratio of mass flow rates  $\dot{m}_w/\dot{m}_{ORC}$ . The second equation is required to find these two unknowns. For that purpose the heat balance of the heating fluid from inlet conditions 6 to the pinch point 7 can be considered:

$$\dot{m}_w C_p(T_6 - T_7) = \dot{m}_{ORC} h_{lv}(T_1) . \quad (5)$$

Expression (5) enables determination of the flow rate ratio  $\dot{m}_w/\dot{m}_{ORC}$  as a function of evaporation temperature of working fluid in ORC installation. If we determine temperature difference  $T_6 - T_7$  from Eq. (5) and then subtract temperature  $T_1$  we can obtain temperature difference  $T_7 - T_1$  in the form:

$$\Delta T_{\min} = T_7 - T_1 = (T_6 - T_1) - \frac{h_{lv}(T_1)}{\frac{\dot{m}_w}{\dot{m}_{ORC}} C_p} . \quad (6)$$

The value of  $T_7 - T_1$  is, on the other hand, equal to the minimum temperature difference between two fluids at pinch point  $\Delta T_{\min}$ , the value which is assumed prior to commencement of calculations. Therefore the ratio of

flow rates  $\dot{m}_w/\dot{m}_{ORC}$  can be expressed as a function of the ‘pinch point’ temperature difference as follows:

$$\frac{\dot{m}_w}{\dot{m}_{ORC}} = \frac{h_{lv}(T_1)}{C_p[(T_6 - T_1) - \Delta T_{\min}]} . \quad (7)$$

The temperature to which the heating fluid can be cooled is calculated from the re-arrangement of Eq. (4) to the form

$$T_{10} = T_6 - \frac{\dot{m}_{ORC} [C_{pORC} (T_1 - T_4) + h_{lv}(T_1)]}{\dot{m}_w C_{pw}} . \quad (8)$$

At this stage the only outstanding issue in calculations is to properly assume the value of evaporation temperature and related to that the value of latent heat of evaporation,  $h_{lv}(T_1)$ . If the evaporation temperature is not correctly assumed the outlet heat source temperature will be too high, indicating poor utilization of the heat source. In such case the calculation procedure is iterative and requires selection of other values of evaporation temperature.

## 2.2 Heat supply to the ORC cycle by the phase changing fluid

A similar analysis can be carried out for the case of the heat source as a fluid changing its phase during the supply of heat to working fluid in ORC. A schematic of such process is has been presented in Fig. 4.

Generally the mean temperature drop, usually regarded as a logarithmic mean temperature difference (LMTD), of the heating fluid in the evaporator will consist of three components, namely that corresponding to desuperheating of heating steam down to saturation conditions,  $LMTD_1$ , its condensation,  $LMTD_2$  and subsequent subcooling,  $LMTD_3$ . That can be written as

$$LMTD = \frac{LMTD_1 + LMTD_2 + LMTD_3}{3} . \quad (9)$$

For the discussed case the overall heat balance of the evaporator is similar to the balance presented in Eq. (1), that is

$$\dot{m}_{ORC} (h_1 - h_4) = \dot{m}_w (h_6 - h_{10}) . \quad (10)$$

The second equation used in this analysis is the heat balance up to the location where the ‘pinch point’ occurs

$$\dot{m}_{ORC} (h_1 - h_5) = \dot{m}_w (h_6 - h_9) . \quad (11)$$

It ought to be remembered that similarly as in the previous case of heating the ORC installation by the single phase fluid the transition from enthalpy  $h_4$  to enthalpy  $h_1$  of the working fluid consists first of heating process of working fluid to evaporation temperature  $T_1$  followed by its subsequent evaporation. Hence enthalpy  $h_1$  can be written as in Eq. (2). Enthalpy  $h_{10}$ , resulting from the heat balance of heating fluid from its inlet temperature  $T_6$  to condensation temperature  $T_7$ , corresponding to pressure at temperature  $T_6$ , subsequent condensation of heating fluid to temperature  $T_8$  and its subcooling to  $T_{10}$  can be written as

$$h_{10} = h_6 - C_{pv}(T_6 - T_7) - h_{lv}(T_7) - C_{pl}(T_8 - T_{10}) . \quad (12)$$

Substitution of Eqs. (2) and (12) to (10) returns

$$\begin{aligned} \frac{\dot{m}_w}{\dot{m}_{ORC}} [C_{pv}(T_6 - T_7) + h_{lv}(T_7) + C_{pl}(T_8 - T_{10})] = \\ = [C_{pORC}(T_1 - T_4) + h_{lv}(T_1)] . \end{aligned} \quad (13)$$

In Eq. (13) unknown are the values of outlet temperature of heating medium  $T_{10}$  and the ratio of mass flow rates  $\dot{m}_w/\dot{m}_{ORC}$ . In order to obtain the second equation enabling determination of the two above quantities we write the heat balance equation for the heat balance from the node 6 to the pinch point, state 9

$$\frac{\dot{m}_w}{\dot{m}_{ORC}} [C_{pv}(T_6 - T_7) + h_{lv}(T_7) + C_{pl}(T_8 - T_9)] = h_{lv}(T_1) . \quad (14)$$

Equation (14) enables determination of the minimum temperature difference at pinch point

$$\Delta T_{\min} = T_9 - T_1 = (T_8 - T_1) - \frac{\frac{\dot{m}_w}{\dot{m}_{ORC}} [C_{pv}(T_6 - T_7) + h_{lv}(T_7)] - h_{lv}(T_1)}{\frac{\dot{m}_w}{\dot{m}_{ORC}} C_{pl}} . \quad (15)$$

On the other hand, if we regard the minimum temperature difference at pinch point as a parameter, then from Eqs. (16) we can determine the ratio  $\dot{m}_w/\dot{m}_{ORC}$ . That reads

$$\frac{\dot{m}_w}{\dot{m}_{ORC}} = \frac{1}{C_{pl}[\Delta T_{\min} - (T_8 - T_1)] + [C_{pv}(T_6 - T_7) + h_{lv}(T_7)] - h_{lv}(T_1)} . \quad (16)$$

Knowing that quantity enables determination of the outlet temperature of the heating fluid  $T_{10}$  in ORC installation from (13)

$$T_{10} = \frac{[C_{pv}(T_6 - T_7) + h_{lv}(T_7) + C_{pl}T_8] - [C_{pORC}(T_1 - T_4) + h_{lv}(T_1)] \left(\frac{\dot{m}_w}{\dot{m}_{ORC}}\right)^{-1}}{C_{pl}} \quad (17)$$

In the considered case it is assumed that the point at which there is the minimum temperature difference between the heating fluid and the ORC working fluid is found on the liquid line of the heating fluid (after its condensation).

### 3 Results

In order to show the performance of the described earlier mathematical model the calculations of temperature drop of the heat source provided in the form of the single phase fluid as well as the phase changing fluid are presented.

#### 3.1 ORC heating using low temperature single phase fluid

In the first case considered is the ORC case heated by the stream of hot water with inlet temperature  $T_6 = 90^\circ\text{C}$  and ethanol as working fluid. Properties of ethanol were taken from Refprop 9.0 [6].

Figure 5 shows the results of calculations of the ratio of the heating fluid flow rate to the flow rate of working fluid in ORC installation in function of temperature before turbine for the minimum pinch point temperature difference  $\Delta T_{min}$  treated as a parameter. It can be immediately seen from that figure that the ratio of the flow rate of heating fluid to the one in ORC installation, namely  $\dot{m}_w/\dot{m}_{ORC}$  is a function of  $\Delta T_{min}$  at the pinch point. In this case we can notice a very significant increase of the ratio  $\dot{m}_w/\dot{m}_{ORC}$  with increasing temperature before the turbine,  $T_1$ , as well as with increasing  $\Delta T_{min}$ . The rise of that ratio is very significant in both respect. For example, in order to obtain evaporation temperature in ORC equal to  $T_1 = 80^\circ\text{C}$  with  $\Delta T_{min} = 5$  K the ratio of the flow rate of water to the flow rate of ethanol must be equal to over forty. Even higher values of that ratio should be warranted when the values of  $\Delta T_{min} > 5$  K. Hence, in case of greater  $\Delta T_{min}$  much lower evaporation temperatures are feasible, but leading also to lower values of  $\dot{m}_w/\dot{m}_{ORC}$  ratio. If we consider for example



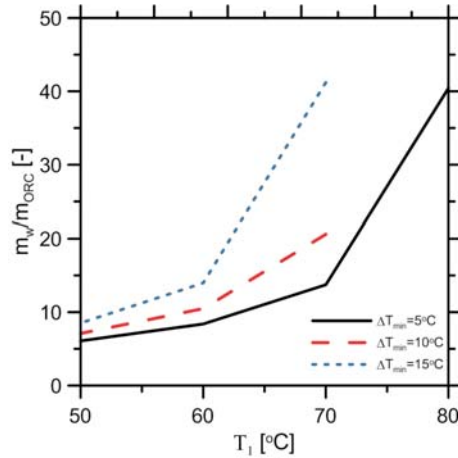

Figure 5. The ratio of mass flow rates  $\dot{m}_w/\dot{m}_{ORC}$  in function of temperature before the turbine for ethanol and inlet hot water temperature  $T_6 = 90^\circ\text{C}$ .

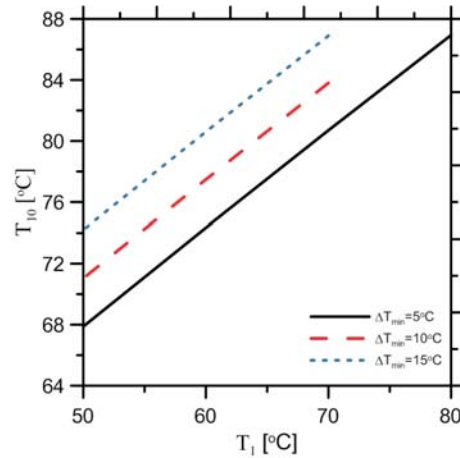

Figure 6. Outlet temperature  $T_{10}$  of hot water heating the ORC installation in function of temperature before the turbine for ethanol and inlet hot water temperature  $T_6 = 90^\circ\text{C}$ .

the evaporation temperature of  $70^\circ\text{C}$  then the smallest ratio  $\dot{m}_w/\dot{m}_{ORC}$  is obtained for the smallest value of  $\Delta T_{min} = 5\text{ K}$ . In that case the ratio of flowrates for  $\Delta T_{min} = 5\text{ K}$  is about ten, whereas for  $\Delta T_{min} = 15\text{ K}$  it is over forty, respectively. In Fig. 6 presented are the results of calculations of outlet temperature  $T_{10}$  of heating fluid in function of temperature before the turbine for different temperatures of evaporation of ethanol. The analysis of Figure 6 gives us the temperature limit to which we can cool down our heat source at a specified evaporation temperature. In the case of selecting the high evaporation temperature of ORC working fluid (say  $75^\circ\text{C}$ , as our heat source is assumed at inlet temperature of  $90^\circ\text{C}$ ) we can reduce the temperature of the heat source only by about 6 K if  $\Delta T_{min} = 5\text{ K}$ . If a higher value of pinch point temperature difference is assumed, say  $\Delta T_{min} = 10\text{ K}$ , then the heat source temperature can only be reduced by less than 2 K. That is regarded as the inefficient use of the available heat source. In case of exploring for example the waste heat from some industrial process that is unacceptable. Another drawback, which is apparent from recalling the data from Fig. 5, is that the  $\dot{m}_w/\dot{m}_{ORC}$  required for achieving this task (high evaporation temperature) is also excessively large. Maximum reduction of the heat source temperature that can be obtained is the one corresponding to the lowest evaporation pressure (temperature) in ORC, in our case, con-

sidered as that related to temperature  $50^{\circ}\text{C}$ . Assuming that the minimum temperature difference at the pinch point should not be less than 5 K we obtain the lowest attainable temperature of our heating medium equal to  $T_{10} = 67^{\circ}\text{C}$ . In case of higher  $\Delta T_{min}$  the outlet source temperatures will be higher, yielding  $71^{\circ}\text{C}$  at  $\Delta T_{min} = 10$  K and  $74^{\circ}\text{C}$  at  $\Delta T_{min} = 15$  K, respectively. At such low evaporation temperatures, on the other hand, the smallest values of thermal efficiency of ORC will be obtained. Hence we should notice that at high evaporation temperatures of ORC working fluid the source remains unexploited to a full potential, but thermal efficiencies of the cycle are higher, whereas satisfactory exploitation of the heat source leads to smaller thermal efficiencies of the cycle.

The presented method of fitting the heat source to the ORC cycle should convince the reader that the issue of the finite capacity of heat source is a very important aspect of the ORC installation design. Presented simple analytical model returns quickly and efficiently the extent to which the available heat source can be explored at assumed evaporation conditions in ORC and the assumed values of pinch point temperature difference. The model can be applied to any fluid combination and therefore should be a useful tool in quick scanning in preselection of working fluids for ORC cycle receiving heat from the limited source.

The calculations show that the value of evaporation temperature of the working fluid  $T_1$  is responsible for the ratio of the mass flow rates of heating fluid flow to ORC fluid as well as for the heating fluid outlet temperature  $T_{10}$ . That has also the bearing on exergy losses in the evaporator which are minimized in case of small temperature differences between the heat source and the working fluid. Such situation is present at small  $\Delta T_{min}$ .

### 3.2 Heat supply by phase changing fluid

In case of the heating fluid condensing whilst supplying heat to ORC the following values of parameters have been assumed. The inlet temperature of the heating fluid is  $T_6 = 228^{\circ}\text{C}$  and pressure  $p_6 = 252$  KPa, which corresponds to the typical parameters of the steam from numerous industrial processes. In the considered case the condensation temperature corresponds to pressure  $p_6$  and yields  $T_7 = T_6 = 127.7^{\circ}\text{C}$ . The ethanol has been considered as a working fluid. In Figs. 7 and 8 presented are the distributions of the ratio of flow rates of steam to working fluid in ORC installation (Fig. 7) and outlet temperature of heating medium  $T_{10}$  which can be attained by specified cooling conditions (Fig. 8). It can be noticed from the analysis of

Fig. 7 that the ratio of flow rate of steam to the flow rate of working fluid in ORC installation  $\dot{m}_w/\dot{m}_{ORC}$  is a function of temperature difference at pinch point. The ratio is decreasing with decreasing temperature  $T_1$ . The flow rate of heating fluid is not as large as in the case of supplying heat using the single phase medium. It amounts to about 33% of the amount of working fluid in ORC installation. It stems from the chart that the lower the  $\Delta T_{min}$  the lower is the required flow rate of heating medium. It also stems from the calculations that the higher is temperature before the turbine the less of heating fluid (condensing steam) is required to heat the working fluid in ORC installation. These conclusions are also confirmed by calculations presented in Fig. 8, where distributions of the heating fluid outlet temperatures are presented. At lower temperatures  $T_1$  the heat source features higher outlet temperatures.

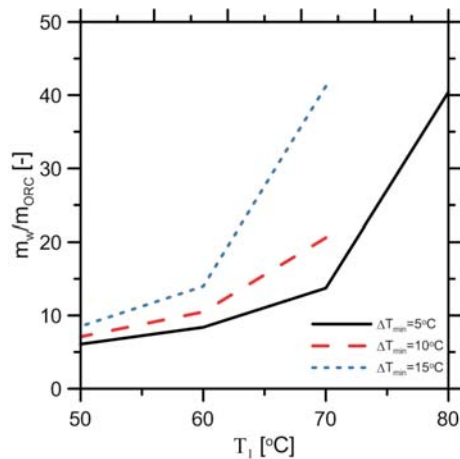

Figure 7. The ratio of mass flow rates  $\dot{m}_w/\dot{m}_{ORC}$  in function of temperature before turbine for different temperatures of evaporation of ethanol and inlet hot water temperature  $T_6 = 90^\circ\text{C}$ .

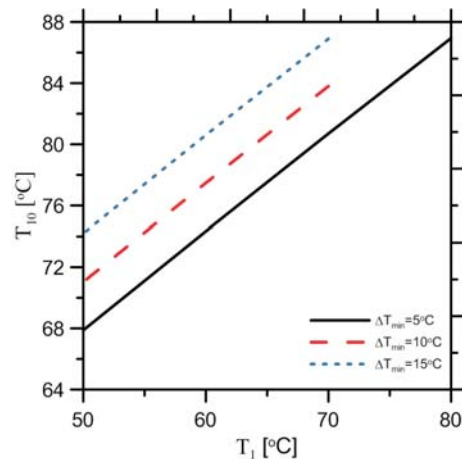

Figure 8. Outlet temperature  $T_{10}$  of hot water heating the ORC installation in function of temperature before turbine for different evaporation temperatures of ethanol and inlet hot water temperature  $T_6 = 90^\circ\text{C}$ .

## 4 Conclusions

In the paper presented have been two cases of supplying heat to ORC installation. First one is by using the single phase fluid and the other one by the phase changing fluid. Both cases have been modeled using the relevant

mathematical expressions of energy balance, which enable determination of the temperature of the heating fluid after its use, the ratio of flow rates of the heating fluid to the working fluid in ORC installation and finally the logarithmic mean temperature difference in the evaporator.

Presented calculations should convince the reader to the fact that the issue of variation of heat source temperature is a very important aspect of designing the ORC installation with external fluid supplying the system with heat. Presented simple relations enable to adjust the appropriate flow rates of the working fluid in ORC installation as well as of heating fluid to the required temperature drop of the heat source. On the basis of that model and incorporation of exergy analysis the thermodynamic criterion for appropriate selection of evaporation temperature and the amount of used fluids can be established. It stems from the accomplished calculations that by changing evaporation temperature of working fluid  $T_1$  we can change the ratio of flow rates  $\dot{m}_w/\dot{m}_{ORC}$  in ORC installation as well as the outlet temperature of heating fluid  $T_{10}$ .

In the case of heating the ORC installation by means of the fluid changing its phase the ratio of flow rates of heating fluid to the working fluid in ORC,  $\dot{m}_w/\dot{m}_{ORC}$ , is a function of temperature difference at pinch point, but with decreasing temperature  $T_1$  (temperature of working fluid vapor before the turbine) that effect is getting smaller. The flow rate of steam must not be in that case a large as in the case of single phase heating fluid. In this case it amounts to about 33% of that of the fluid in ORC installation. The smaller the  $\Delta T_{min}$  the smaller flow rate of heating medium to ORC is required.

**Acknowledgement** The results presented in this paper were obtained from research work cofinanced by the National Centre of Research and Development in the framework of Contract SP/E/1/67484/10 – Strategic Research Programme – Advanced technologies for obtaining energy: Development of a technology for highly efficient zero-emission coal-fired power units integrated with CO<sub>2</sub> capture.

*Received 2 August 2013*

## References

- [1] MIKIELEWICZ D., MIKIELEWICZ J.: *Utilisation of bleed steam heat to increase the upper heat source temperature in low-temperature ORC*. Arch. Thermodyn.

- 32**(2011), 3, 57–70.
- [2] LIU B-T, CHIEN K-H, WANG C-C.: *Effect of working fluids on organic Rankine cycle for waste heat recovery*. Energy **29**(2004), 1207–1217.
- [3] SALEH B., KOGLBAUER G., WENDLAND M., FISCHER J.: *Working fluids for low-temperature organic Rankine cycles*. Energy **32**(2007), 1210–1221.
- [4] LAKEW A.A., BOLLAND O.: *Working fluids for low-temperature heat Skurce*. Appl. Therm. Eng. **30**(2010), 1262–1268.
- [5] KHENNICH M., GALANIS N.: *Thermodynamic analysis and optimization of power cycles using a finite low-temperature heat source*. Int. J. Energ. Res. 2011, Res. DOI:10.1002/er.1839.
- [6] *Refprop 9.0*. National Institute of Standards, 2010.