

## **Illustration of the elliptical field in the screened flat 3-phase high current busduct**

Dariusz Kusiak

Czestochowa University of Technology

42-200 Częstochowa, Aleja Armii Krajowej 17, e-mail: dariuszkusiak@wp.pl

Zygmunt Piątek, Tomasz Szczegielniak

Czestochowa University of Technology

42-200 Częstochowa, ul. Brzeźnicka 60a, e-mail: zygmunt.piatek@interia.pl, szczegielniakt@interia.pl

The paper demonstrates the elliptical magnetic field in the flat 3-phase high current screened busduct in the context of the both the external and internal proximity effect. The modules and the amplitudes of the complex components of the magnetic field strength in the high-current busducts of this type are the functions of the two variables:  $r$  and  $\theta$  of the cylindrical coordinate system which subsequently provokes to the conclusion that the harmonic magnetic field in shielded high-current busducts is a rotating elliptical field. For the characterisation of complex vector values for this field, it is suggested that the length of the longer semi axis of an ellipse as showed at the end of the vector within one period should be used. The article presents the elliptic magnetic field in the screen, and the internal and external area of the screen of the flat 3-phase high current busduct.

### **1. Introduction**

The design and construction of busducts to take ever-increasing currents and voltages have resulted in the necessity for a precise description of electromagnetic effects, including the maximum magnetic field values [1-3].

One of the structural sources for the construction of high current busducts is provided in the shape of the so-called flat three-pole high current busduct (Fig. 1) [4].

The variable intensity values of magnetic fields emitted by such busducts are large, even in rated current conditions [5-6].

Component amplitudes of the magnetic field intensity are not generally identical, and furthermore these components have different starting phases, i.e.  $H_r(r, \theta) \neq H_\theta(r, \theta)$  and  $\varphi_r(r, \theta) \neq \varphi_\theta(r, \theta)$ . M. Krakowski presents in his work [7] a nonnegative value in the form of complex vector norms

$$\|\mathbf{H}(r, \theta)\| = \sqrt{\mathbf{H}(r, \theta) \cdot \mathbf{H}^*(r, \theta)} \quad (1)$$

Such a defined norm does not consider differing starting phases ( $\varphi_r(r, \theta) \neq \varphi_\theta(r, \theta)$ ) of magnetic field intensity components, thus it does not provide for the elliptical nature of this field [8].

a)

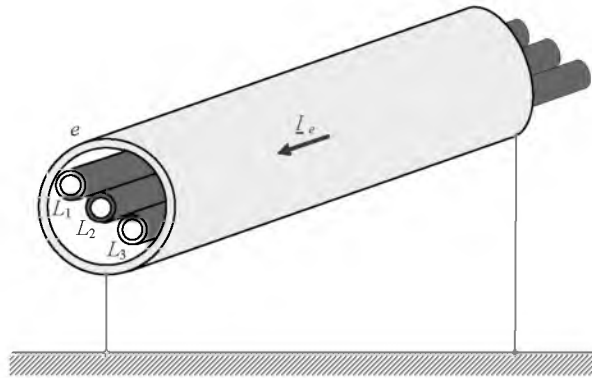

b)

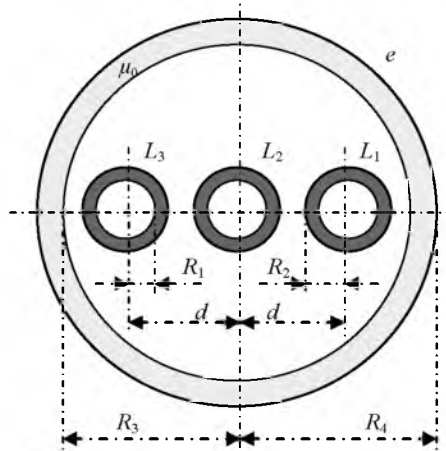

Fig. 1. 3-pole screened flat high current busduct: a) general view, b) cross section

Works [9-13] show that magnetic fields at point  $P(r, \theta)$  may be demonstrated as the superposition of two fields flowing in opposite directions. The sum of these fields is presented in the ellipse – Figure 2.

Works [15-18] and figure 2 indicate the semi axes of the elliptic magnetic field. The value of the longer semi axis takes the form

$$H_a(r, \theta) = \max_{t \in (0, T)} H(r, \theta, t) = H_1(r, \theta) + H_2(r, \theta) \quad (2)$$

whereas the shorter semi axis is expressed as

$$H_b(r, \theta) = \min_{t \in (0, T)} H(r, \theta, t) = |H_1(r, \theta) - H_2(r, \theta)| \quad (3)$$



Components vector  $\underline{H}_3^{\text{int}}(r, \Theta)$  are expressed with the formulas

$$\underline{H}_{r3}^{\text{int}}(r, \Theta) = -\frac{I_3}{2\pi} \sum_{n=1}^{\infty} \left[ \frac{1}{r} \left(\frac{d}{r}\right)^n - \frac{r^{n-1}}{R_3^n} \left(\frac{d}{R_3}\right)^n \frac{p_n}{d_n} \right] \sin n\Theta \quad (8)$$

and

$$\underline{H}_{\Theta 3}^{\text{int}}(r, \Theta) = \frac{I_3}{2\pi r} + \frac{I_3}{2\pi} \sum_{n=1}^{\infty} \left[ \frac{1}{r} \left(\frac{d}{r}\right)^n + \frac{r^{n-1}}{R_3^n} \left(\frac{d}{R_3}\right)^n \frac{p_n}{d_n} \right] \cos n\Theta \quad (8a)$$

The phase currents are symmetric

$$\underline{I}_2 = \exp[-j\frac{2}{3}\pi] \underline{I}_1 \quad \text{and} \quad \underline{I}_3 = \exp[j\frac{2}{3}\pi] \underline{I}_1 \quad (9)$$

The magnetic field components (4) can be compared with the following field

$$\underline{H}_0 = \frac{\underline{I}_1}{2\pi R_2},$$

and gain their relative forms. After that, we derive formulas for the relative components of the total magnetic field in the internal area of the screen ( $0 \leq r \leq R_3$  or  $0 \leq \xi \leq \beta$ ) of the 3-phase, 3-pole, flat, high-current busduct.

These components have the form [19]

$$\underline{h}_r^{\text{int}}(\xi, \Theta) = -\sum_{n=1}^{\infty} \left[ (-1)^n + \exp\left(j\frac{2}{3}\pi\right) \right] \left[ \frac{(\beta\lambda)^n}{\xi^{n+1}} - \left(\frac{\lambda}{\beta}\right)^n \frac{p_n}{d_n} \xi^{n-1} \right] \sin n\Theta \quad (10)$$

and

$$\underline{h}_{\Theta}^{\text{int}}(\xi, \Theta) = \sum_{n=1}^{\infty} \left[ (-1)^n + \exp\left(j\frac{2}{3}\pi\right) \right] \left[ \frac{(\beta\lambda)^n}{\xi^{n+1}} + \left(\frac{\lambda}{\beta}\right)^n \frac{p_n}{d_n} \xi^{n-1} \right] \cos n\Theta \quad (10a)$$

while  $0 \leq \xi \leq \beta$  and  $0 \leq \Theta \leq 2\pi$ . In the above formulas

$$\underline{p}_n = I_{n-1}(\sqrt{2j\alpha}) K_{n-1}(\sqrt{2j\alpha\beta}) - I_{n-1}(\sqrt{2j\alpha\beta}) K_{n-1}(\sqrt{2j\alpha}) \quad (10b)$$

and

$$\underline{d}_n = I_{n-1}(\sqrt{2j\alpha}) K_{n+1}(\sqrt{2j\alpha\beta}) - I_{n+1}(\sqrt{2j\alpha\beta}) K_{n-1}(\sqrt{2j\alpha}) \quad (10c)$$

where  $\alpha = kR_4$  for  $k = \sqrt{\frac{\omega\mu\gamma}{2}} = \frac{1}{\delta}$ ,  $\beta = \frac{R_3}{R_4}$  ( $0 \leq \beta \leq 1$ ),  $\lambda = \frac{d}{R_3}$  ( $0 \leq \lambda < 1$ )

and  $\xi = \frac{r}{R_4}$ .

The functions in the above formulas  $I_{n-1}(\sqrt{2j}\alpha)$ ,  $K_{n+1}(\sqrt{2j}\alpha\beta)$ ,  $I_{n+1}(\sqrt{2j}\alpha\beta)$  and  $K_{n-1}(\sqrt{2j}\alpha)$  are the modified Bessel functions of the first and second order, respectively i.e.:  $n-1$  and  $n+1$  [20].

The distribution of these components for the total magnetic field in the internal area of the screen of the flat three-phase high current busduct is illustrated in Figures 3 and 4.

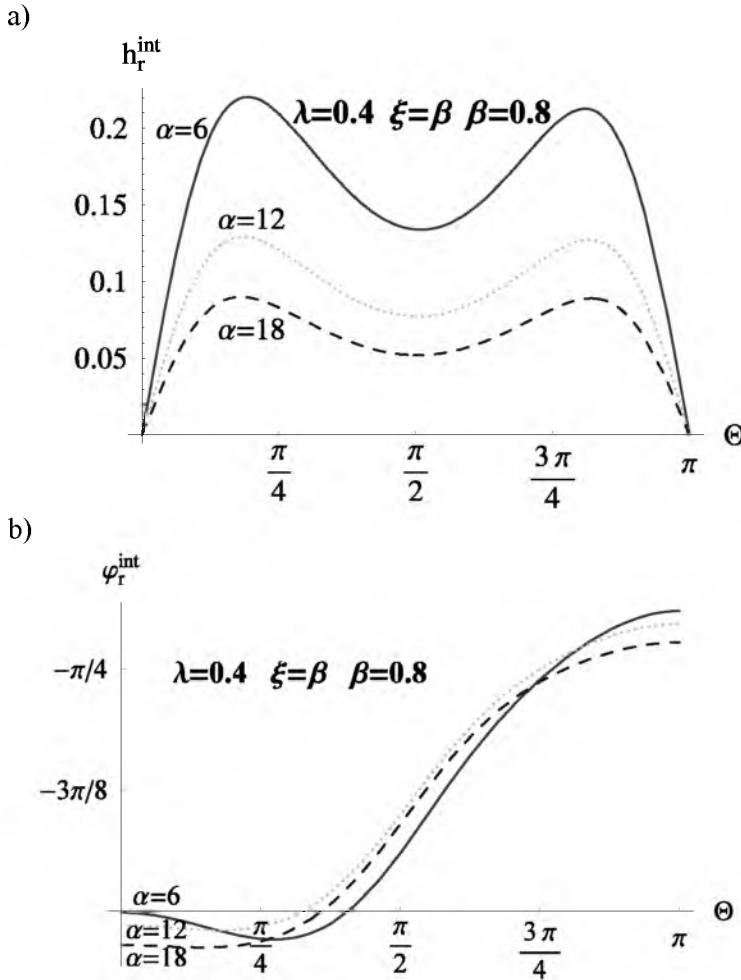

Fig. 3. The distribution of relative radial component values for the total magnetic field in the internal area of the screen of the flat three-phase high current busduct: a) the modulus, b) the argument

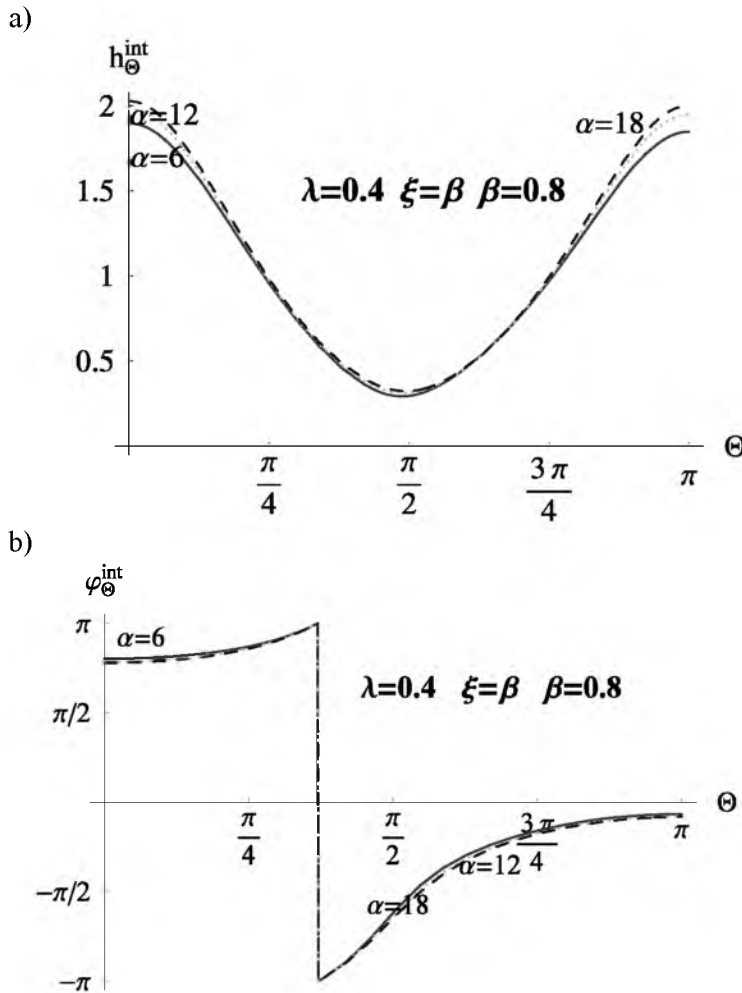

Fig. 4. The distribution of relative tangent component values for the total magnetic field in the internal area of the screen of the flat three-phase high current busduct:  
a) the modulus, b) the argument

The set of arguments for the radial and tangential field components vary considerably and therefore at each point measured in a magnetic field, the field is elliptic, which is characterised by lengths  $h_a(r, \Theta)$  and  $h_b(r, \Theta)$  of the ellipse semi axes [21] – Figure 5.

The highest value of the magnetic field intensity, and precisely the value of its module should be determined from the formula (2) – Figure 6.

The comparison of relative value  $h_a$  showed in formula (2) with value  $h = \|h\|$  indicated in formula (1) in the internal area of the screen with the determined value of angle  $\Theta$  for variable parameter  $\alpha$  is demonstrated in figure 7 [22].

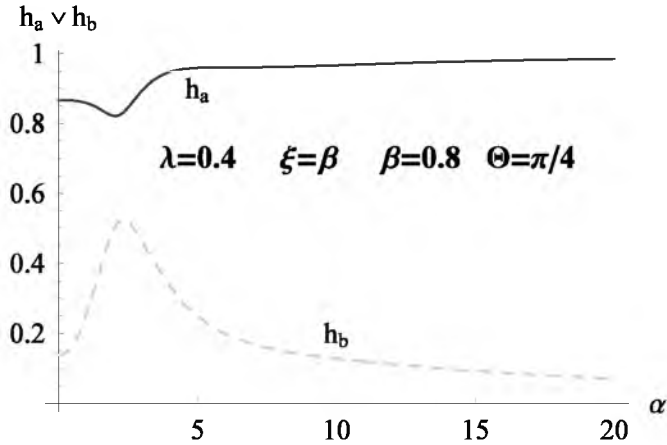

Fig. 5. The distribution of relative values of lengths ellipsis semi axes of the magnetic field in the internal area of the screen of the flat three-phase high current busduct

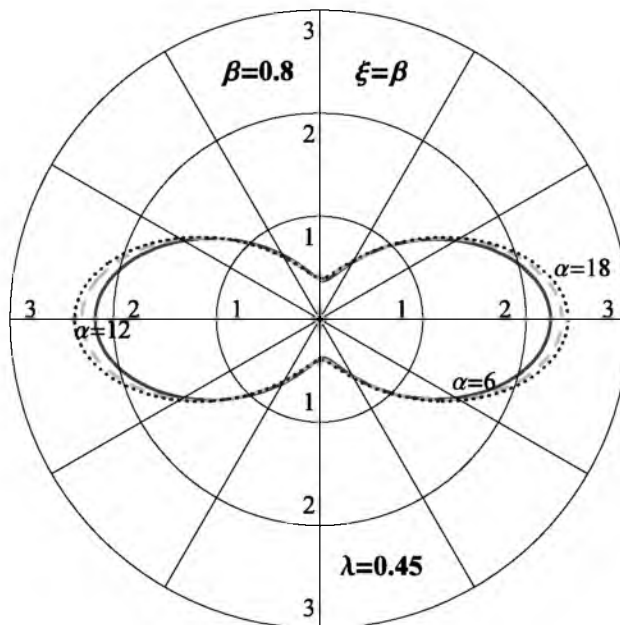

Fig. 6. The distribution of relative the total magnetic field modulus in the internal area of the screen of the flat three-phase high current busduct

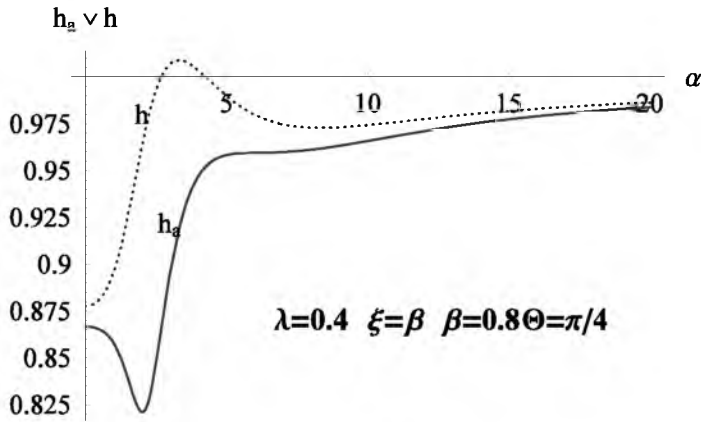

Fig. 7. The distribution of relative values  $h_a$  and  $h = \|h\|$  within the function of parameter  $\alpha$  in the internal area of the screen

### 3. Elliptical magnetic fields in the the screen of the flat 3-phase high current busduct

The magnetic field in the screen ( $R_3 \leq r \leq R_4$ ) is defined with the following formula [23]

$$\underline{H}_e(r, \Theta) = \underline{H}_{e1}(r, \Theta) + \underline{H}_{e2}(r, \Theta) + \underline{H}_{e3}(r, \Theta) \quad (11)$$

Formulas the relative components of the total magnetic field in the screen ( $R_3 \leq r \leq R_4$  or  $\beta \leq \xi \leq 1$ ) of the flat three-phase high current busduct are exhibited as

$$\underline{h}_{er}(\xi, \Theta) = \frac{2}{\sqrt{2j} \alpha \beta \xi} \frac{1}{\sum_{n=1}^{\infty} \left[ (-1)^n + \exp\left(j \frac{2}{3} \pi\right) \right]} n \underline{g}_n(\xi) \sin n\Theta \quad (12)$$

and

$$\underline{h}_{e\Theta}(\xi, \Theta) = \frac{2}{\sqrt{2j} \alpha \beta \xi} \frac{1}{\sum_{n=1}^{\infty} \left[ (-1)^n + \exp\left(j \frac{2}{3} \pi\right) \right]} \underline{f}_n(\xi) \cos n\Theta \quad (12a)$$

where

$$\underline{g}_n(\xi) = -\lambda^n \frac{K_{n-1}(\sqrt{2j} \alpha) I_n(\sqrt{2j} \alpha \xi) + I_{n-1}(\sqrt{2j} \alpha) K_n(\sqrt{2j} \alpha \xi)}{\underline{d}_n} \quad (12b)$$

and



$$\underline{f}_{-n}(\xi) = (\lambda)^n \frac{1}{\underline{d}_n} \left\{ K_{n-1}(\sqrt{2j}\alpha) \left[ n I_n(\sqrt{2j}\alpha\xi) - \sqrt{2j}\alpha\xi I_{n-1}(\sqrt{2j}\alpha\xi) \right] + \right. \\ \left. + I_{n-1}(\sqrt{2j}\alpha) \left[ n K_n(\sqrt{2j}\alpha\xi) + \sqrt{2j}\alpha K_{n-1}(\sqrt{2j}\alpha\xi) \right] \right\} \quad (12c)$$

The distribution of these components is illustrated in Figures 8 and 9.

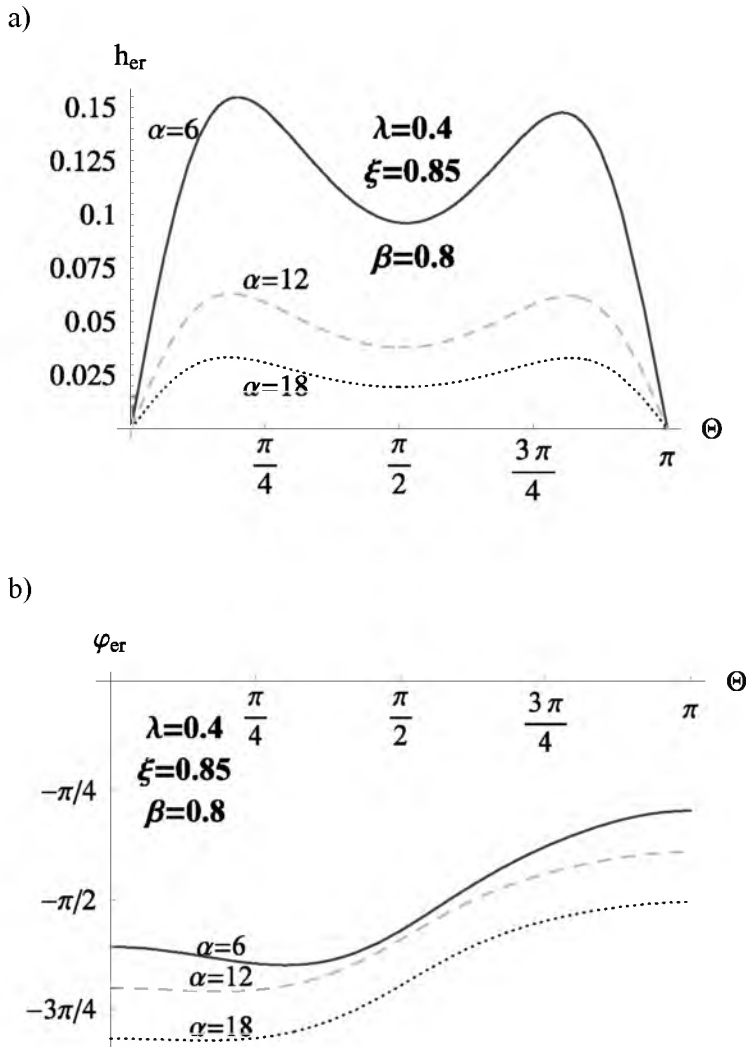

Fig. 8. The distribution of relative radial component values for the total magnetic field in the screen of the flat three-phase high current busduct: a) the modulus, b) the argument

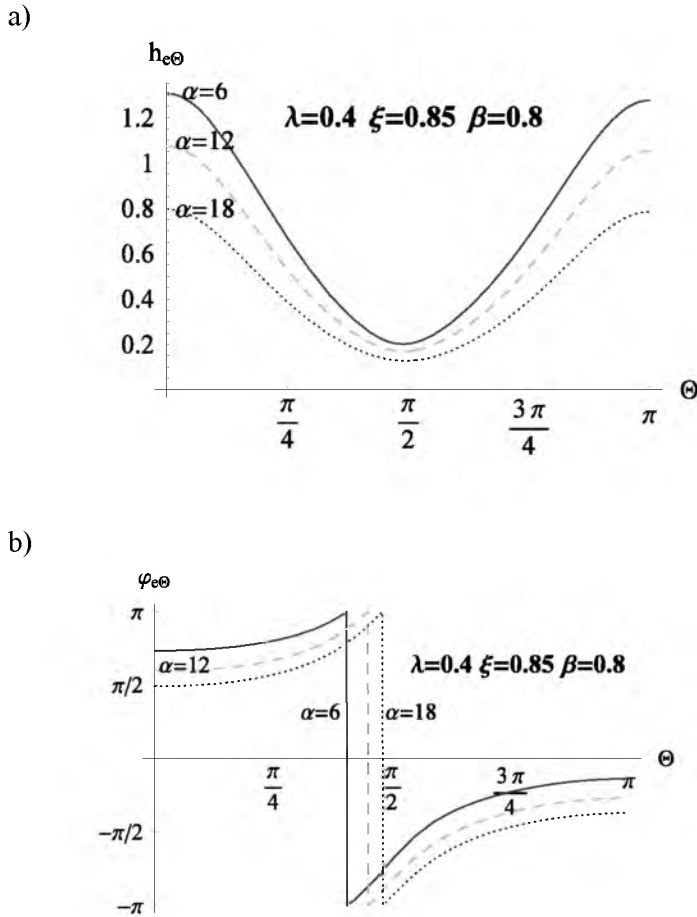

Fig. 9. The distribution of relative tangent component values for the total magnetic field in the screen of the flat three-phase high current busduct: a) the modulus, b) the argument

Component amplitudes of magnetic field intensity within the insulation are not identical, and furthermore have different starting phases, and therefore the magnetic field is an elliptical field, which is characterised by lengths  $h_a(r, \Theta)$  and  $h_b(r, \Theta)$  of the ellipsis semi axes – Figure 10.

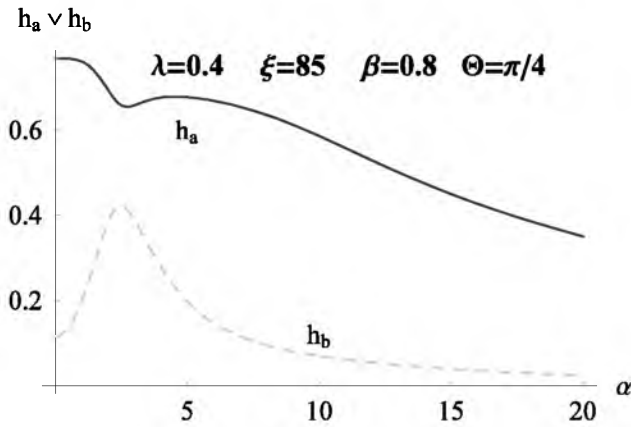

Fig. 10. The distribution of relative values of lengths  $h_a(r, \Theta)$  and  $h_b(r, \Theta)$  of the magnetic field ellipsis semi axes in the screen

We are most frequently interested in the maximum magnetic field intensity value – Figure 11.

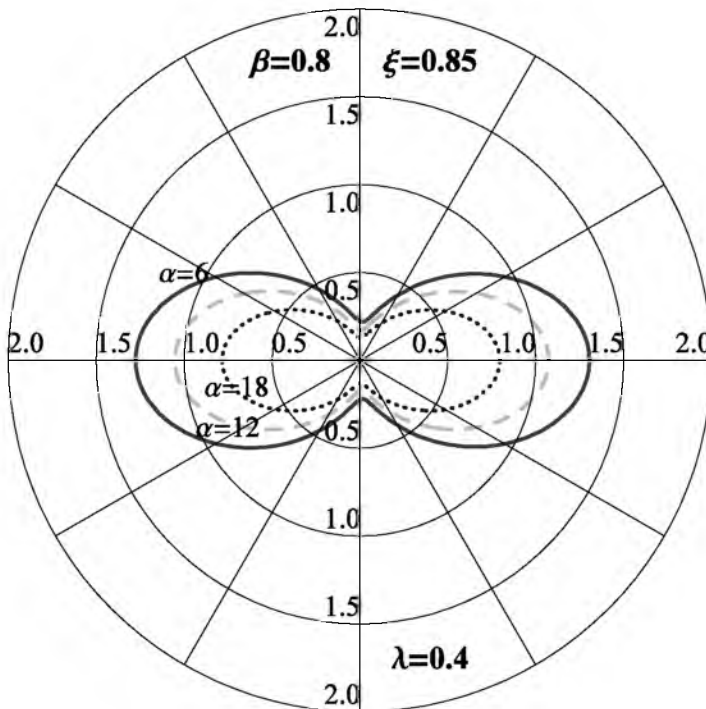

Fig. 11. The distribution of the relative modulus quantity of the total magnetic field in the screen of the flat three-phase high current busduct

The comparison of the relative value  $h_a$  with value  $h = \|h\|$  in the screen with the specified value of angle  $\Theta$  for variable parameter  $\alpha$  is presented in Figure 12.

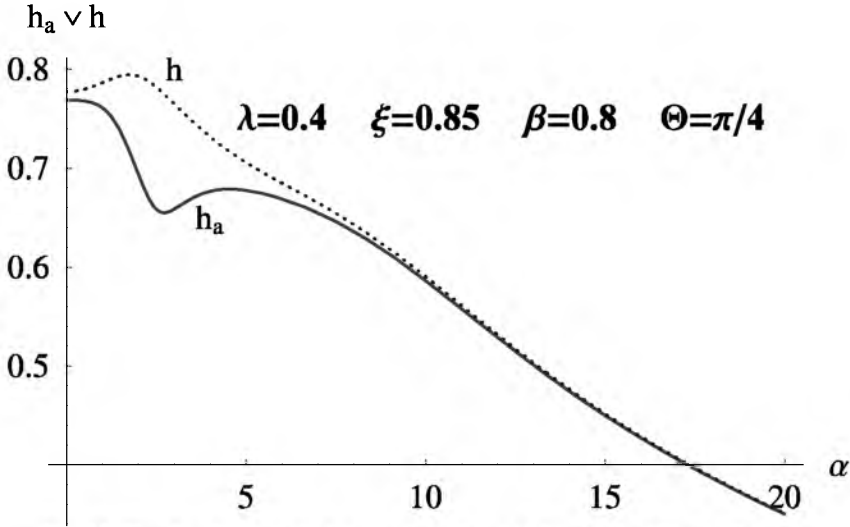

Fig. 12. The distribution of relative values  $h_a$  and  $h = \|h\|$  within the function of parameter  $\alpha$  in the screen

#### 4. Elliptical magnetic fields in the external area of the screen of the flat 3-phase high current busduct

The magnetic fields in the external area of the screen ( $r \geq R_4$ ) is defined with the following formula [24]

$$\underline{H}^{ext}(r, \Theta) = \underline{H}_1^{ext}(r, \Theta) + \underline{H}_2^{ext}(r, \Theta) + \underline{H}_3^{ext}(r, \Theta) \quad (13)$$

The relative component formulas of the total magnetic field in the external area of the screen ( $r \geq R_4$  or  $\xi \geq 1$ ) of the flat three-phase high current busduct are expressed as [24]

$$\underline{h}_r^{ext}(\xi, \Theta) = -\sum_{n=0}^{\infty} \left[ (-1)^n + \exp\left(j \frac{2}{3} \pi\right) \right] \frac{1}{\beta} \frac{s_n}{d_n} \frac{\lambda^n}{\xi^{n+1}} \sin n\Theta \quad (14)$$

and

$$\underline{h}_\Theta^{ext}(\xi, \Theta) = \sum_{n=1}^{\infty} \left[ (-1)^n + \exp\left(j \frac{2}{3} \pi\right) \right] \frac{1}{\beta} \frac{s_n}{d_n} \frac{\lambda^n}{\xi^{n+1}} \cos n\Theta \quad (14a)$$

The distribution of these components is illustrated in Figures 13 and 14.

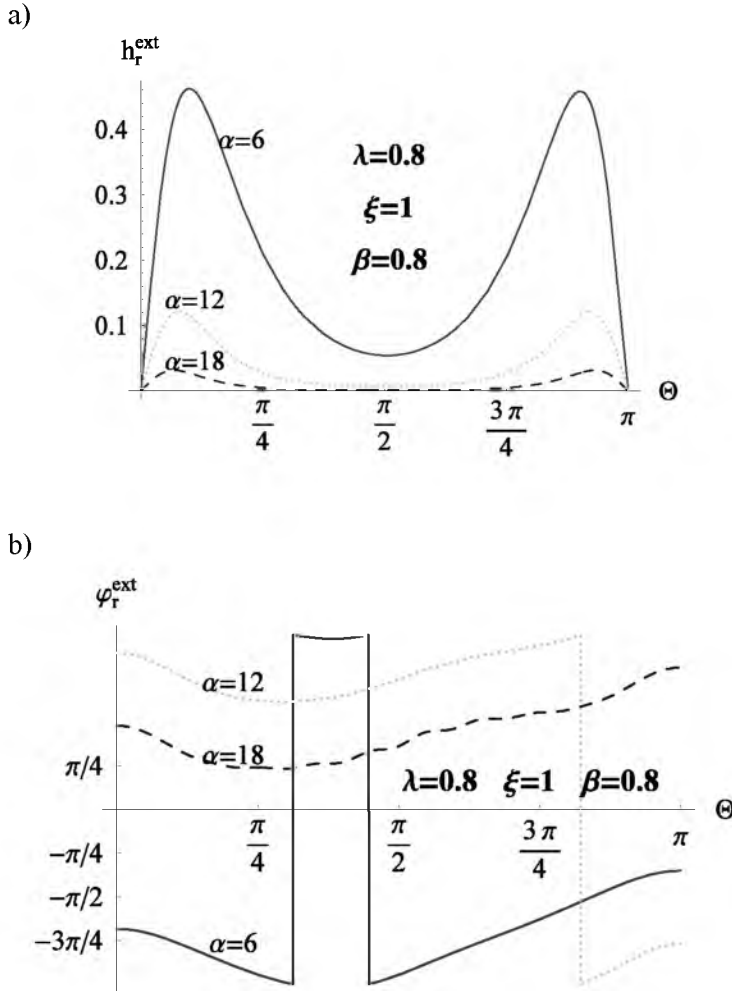

Fig. 13. The distribution of relative radial component values for the total magnetic field in the external area of the screen of the flat three-phase high current busduct:  
a) the modulus, b) the argument

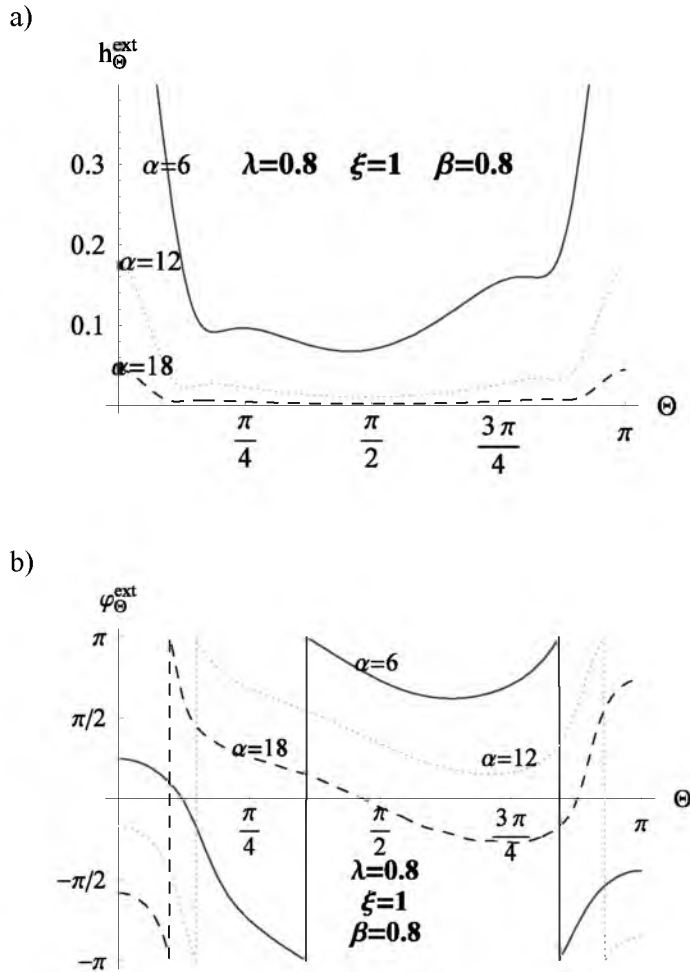

Fig. 14. The distribution of relative tangent component values for the total magnetic field in the external area of the screen of the flat three-phase high current busduct: a) the modulus, b) the argument

The arguments of the components of the  $\underline{H}^{ext}(r, \Theta)$  magnetic field in the external area are, following the previous cases, the functions of  $\xi$  and  $\Theta$  variables. This means that this field is elliptic. This elliptic field can be characterised by the  $h_a(r, \Theta)$  and  $h_b(r, \Theta)$  lengths of the ellipse semi-axis – Figure 15.

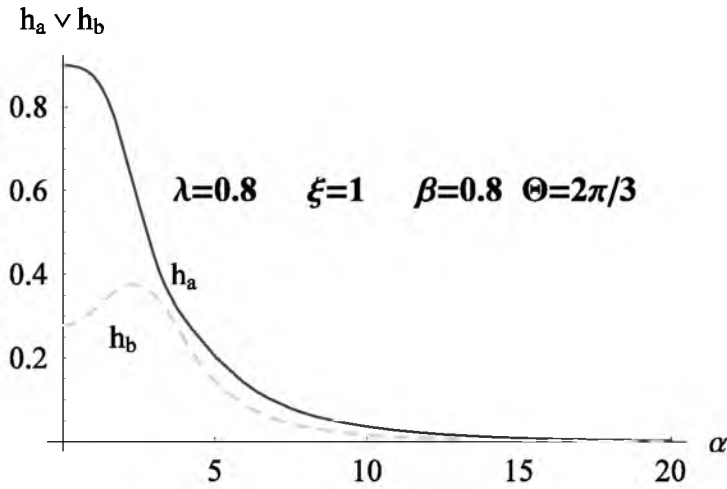

Fig. 15. The distribution of relative values of lengths  $h_a(r, \Theta)$  and  $h_b(r, \Theta)$  of the magnetic field ellipsis semi axes in the external area of the screen

We are most frequently interested in the maximum magnetic field intensity value – Figure 16.

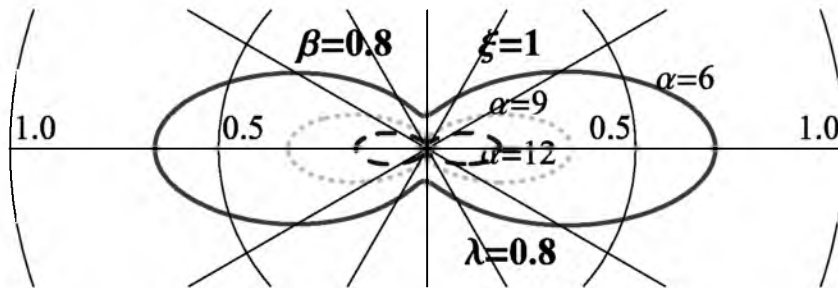

Fig. 16. The distribution of the relative modulus quantity of the total magnetic field in the external area of the screen of the flat three-phase high current busduct

The comparison of relative value  $h_a$  with value  $h = \|h\|$  in the external area of the screen with the specified value of angle  $\Theta$  for variable parameter  $\alpha$  is presented in Figure 17.

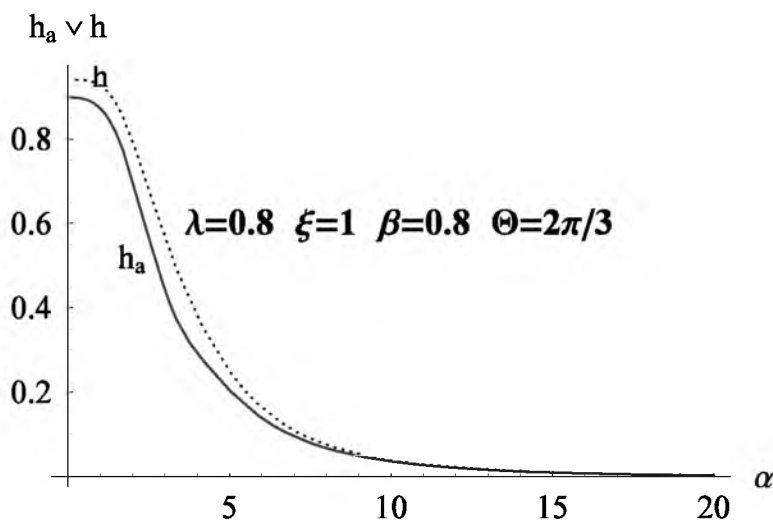

Fig. 17. The distribution of relative values  $h_a$  and  $h = \|h\|$  within the function of parameter  $\alpha$  in the external area of the screen

## 5. Conclusions

To conclude, in case of a shielded 3-phase flat high current busduct the skin effects and the internal proximity effect cause an uneven magnetic field distribution both in the shield and in its internal and external areas. Resultant magnetic field has two constants of differing amplitudes and commencing phases. This results in the field being an elliptic field. For its characterisation we should use the length values (measurements)  $H_a(r, \theta)$  for both the longer and  $H_b(r, \theta)$  for the shorter ellipsis semi axis and the angle  $\Phi(r, \theta)$  between the longer semi axis and axis of abscissa. These values may be demonstrated after defining complex constant values for the magnetic fields – formulae (2), (2a) and (3) respectively.

In transmission lines values  $H_a(r, \theta)$ ,  $H_b(r, \theta)$  and  $\Phi(r, \theta)$  change depending on the position of point  $P(r, \theta)$ . Based on the above calculations (figures 5, 10 and 15) it can be stated that the form of the magnetic field is a narrow ellipse, where  $H_b(r, \theta) \gg H_a(r, \theta)$ .

In technological processes, a significant value is the highest value for the magnetic field intensity. In the case of elliptic fields, this value is accepted as length  $H_a(r, \theta)$  of the longer ellipsis semi axis. In busducts observed in practise for power frequencies, the value of parameter  $\alpha$  is between 5 and 20. This means that for the flat 3-phase high current busduct, the value  $H_a(r, \theta)$  is lower than the



norm value  $\|\underline{H}(r, \Theta)\|$  indicated in the formula (1) – Figures 7, 12 and 17. Within the range of  $2 \leq \alpha \leq 13$  the difference between  $H_a(r, \Theta)$  and  $\|\underline{H}(r, \Theta)\|$  can reach approximately several (Fig. 12 and 17) of a dozen or so percent (Fig 7).

## References

- [1] Nawrowski R.: High-current air or SF<sub>6</sub> insulated busducts (in Polish), *Wyd. Pol. Poznańskiej*, Poznań 1998.
- [2] Piątek Z.: Modeling of lines, cables and high-current busducts (in Polish), *Wyd. Pol. Częst.*, Częstochowa 2007.
- [3] CIGRE Brochure No 218.: Gas Insulated Transmission Lines (GIL), WG 23/21/33-15, *CIGRE*, Paris 2003.
- [4] Piątek Z.: Eddy currents induced in the screen of the three-phase symmetrical transmission line (in Polish), *Wiadomości Elektrotechniczne*, Rok LXXVI, Nr 3/2008, ss. 17-21.
- [5] Okamura K., Ishiyama F., Kawamura T.: Characteristics of Power Frequency Field in Three Phase Enclosure Type GIL Model, *High Voltage Engineering Symposium*, 22-27 August 1999, Conference Publication No. 467, © IEE, 1999, pp. 2.19S2-2.22.S2.
- [6] Baron B., Piątek Z.: Impedance and magnetic field of a tubular conductor of finite length (in Polish), *XXIII IC SPETO*, Gliwice-Ustroń 2000, ss. 477-484.
- [7] Krakowski M.: Theoretical electrotechnics. Electromagnetic fields (in Polish), *WN PWN*, Warsaw 1995.
- [8] Kusiak D.: Description of elliptic field in unshielded bifilar transmission line (in Polish), *XV Conference Computer Applications in Electrical Engineering*, ISBN 978-83-89333-34-6, Poznań 2010.
- [9] Piątek Z., Kusiak D., Szczegieliński T.: Elliptical magnetic field in the high current busducts (in Polish), *Przegląd Elektrotechniczny*, ISSN 0033-2097, R. 86 NR 4/2010, p.101-106.
- [10] Piątek Z., Kusiak D., Szczegieliński T.: Magnetic field of the three-phase symmetrical high current busduct (in Polish), *Zesz. Nauk. Pol. Śl. 2009, Elektryka*, z.1(209), pp. 37-50.
- [11] Piątek Z.: Impedances of Tubular High Current Busducts. Series Progress in High-Voltage technique, Vol. 28, *Polish Academy of Sciences, Committee of Electrical Engineering, Wyd. Pol. Częst.*, Częstochowa 2008.
- [12] Kusiak D.: Magnetic field of two- and three-pole high current busducts, Dissertation doctor (in Polish), *Pol. Częst.*, *Wydz. Elektryczny*, Częstochowa 2008.
- [13] Piątek Z.: Magnetic field in high-current isolated-phase enclosed busducts surroundings (in Polish), *Zesz. Nauk. Pol. Śl. 1999, Elektryka*, z. 166.
- [14] Piątek Z., Kusiak D., Szczegieliński T.: Magnetic field of the three phase flat high current busduct (in Polish), *Zesz. Nauk. Pol. Śl. 2009, Elektryka*, z.1(209), pp. 51-65
- [15] Piątek Z, Kusiak D., Szczegieliński T.: Magnetic field of the shielded conductor (in Polish), *Przegląd Elektrotechniczny*, ISSN 0033-2097, R. 85, Nr 5, 2009, ss. 92-95.
- [16] Piątek Z., Kusiak D., Szczegieliński T.: Magnetic field of double-poles high current busduct (in Polish), *Zesz. Nauk. Pol. Śl. 2009, Elektryka*, z.1(209), pp. 67-87.

- [17] Piątek Z., Kusiak D., Szczegielniak T.: Elliptic field problems in a screened symmetrical busduct, *XXXIII IC SPETO*, Gliwice-Ustroń 2010.
- [18] Piątek Z., Kusiak D., Szczegielniak T.: Reverse reaction magnetic field in of two-wire high current busduct (in Polish), *XV Conference Computer Applications in Electrical Engineering*, ISBN 978-83-89333-34-6, Poznań 2010.
- [19] Kusiak D., Piątek Z., Szczegielniak T.: Aspect of the elliptical field in the screened flat three-phase high current busduct. Part I –in the internal area of the screen, *Electrical Engineering*, Iss.69, ISSN 1897-0737, s.127-134.
- [20] Mc Lachan N.W.: *Bessel functions for engineers* (in Polish), PWN, Warsaw 1964.
- [21] Kusiak D.: Use elliptical magnetic fields in unscreened flat three phase busduct, *XXXIII IC SPETO*, Gliwice-Ustroń 2010.
- [22] Kusiak D.: The meaning of the elliptical field in the screened flat three-phase high current busduct, 10th International Workshop "Computational Problems of Electrical Engineering", ISBN 978-80-7043-899-2, s. 24, Lazne Kynzvar, Czech Republic 2010.
- [23] Piątek Z.: Method of Calculating Total Eddy Currents Induced In Screens of a Symmetrical Three-Phase Single-Pole Gas-Insulated Transmission Line, *Acta technika CSAV*, no 53, 2008, pp. 103-120.
- [24] Kusiak D., Piątek Z., Szczegielniak T.: Aspect of the elliptical field in the screened flat three-phase high current busduct. Part II – in the screen and in the external area of the screen, *Electrical Engineering*, Iss.69, ISSN 1897-0737, s.135-142.

### **Acknowledgments**

*This work is financed by the Polish National Science Centre as research project N N511 312540.*