



© 2022. The Author(s). This is an open-access article distributed under the terms of the Creative Commons Attribution-ShareAlike 4.0 International Public License (CC BY SA 4.0, <https://creativecommons.org/licenses/by-sa/4.0/legalcode>), which permits use, distribution, and reproduction in any medium, provided that the article is properly cited, the use is non-commercial, and no modifications or adaptations are made

# Solidification/Stabilization Treatment for organic oil immobilization in Algerian Petroleum Drill Cuttings: Optimization and Acceptance Tests for Landfilling

Abbas Hadj Abbas<sup>1,2\*</sup>, Abidi Saad Aissa<sup>1</sup>, Khodja Mohamed<sup>3</sup>, Sagala Farad<sup>2,4</sup>,  
Hacini Messaoud<sup>1</sup>

<sup>1</sup>Laboratoire de géologie du Sahara, Université Kasdi Merbah Ouargla,  
Route de Ghardaia BP 511 Ouargla Algérie.

<sup>2</sup>Department of Chemical and Petroleum Engineering, University of Calgary,  
2500 University Street NW, Calgary, AB, T2N1N4, Canada

<sup>3</sup>SONATRACH/Institut Algérien du Pétrole, Avenue 1 Novembre 35000 Boumerdès, Algeria

<sup>4</sup>Department of Energy, Minerals and Petroleum Engineering, Faculty of Applied Sciences and Technology, Mbarara,  
University of Science and Technology (MUST), Kihumuro Campus, Mbarara, Uganda

\*Corresponding author's e-mail: [abbashadjabbas@gmail.com](mailto:abbashadjabbas@gmail.com)

**Keywords:** compressive strength, Portland cement, solidification/stabilization, drill cuttings, Total Petroleum Hydrocarbon (TPH)

**Abstract:** Hassi Messaoud oil field is one of the most important fields in Algeria and the world, because it covers an important quantity of total Crude Oil Production in Algeria. Furthermore, two-thirds of this oil field is underexplored or not explored. Therefore, the drilling process of petroleum wells in this field is a continuous process that results in significant drilling waste. This implies that enormous noxious quantities of drilling waste are produced daily that require treatment via solidification/stabilization (S/S) process before being landfilled. These types of wastes have pollution concentration that significantly exceeds the safety standards. In this study, we focus on the factors affecting the solidification/stabilization treatment of the drill cuttings obtained from Hassi Messaoud oil field and the process optimization. The solidification/stabilization is performed using the cement as binder, and sand, silicate, organophilic clay and activated carbon as additives.

The study has been divided into two steps:

- (i) Determining the optimum ratio of each element used in the S/S process for the organic element (hydrocarbon) elimination,
- (ii) Combining the optimum ratios found in the previous step to determine the optimal mixture.

The obtained results in the first step showed that the optimum ratio for the cement-to-drill cuttings mass ratio is **0.09:1**. For the additives-to-drill cuttings mass ratios are **0.04:1**, **0.006:1**, **0.013:1** and **0.013:1** for the sand, sodium silicate, organophilic clay and activated carbon, respectively. An optimum formula is found whose main finding shows that the hydrocarbon content of our sample is dropped from 9.40 to 1.999%. Many tests' results such as matrix permeability, resistance to free compression and heavy metals rate before and after S/S process were investigated before landfilling. Besides that, in the light of outcomes achieved by this assessment, these harmful cuttings can be converted into a useful product that helps in reducing the environmental foot prints.

## Introduction

Crude oil and natural gas are among the most important energy sources in the world (Yoon et al. 2009). The process of crude oil extraction involves several stages, the most important of which is drilling. Basically, drilling activities result in significant amount of cuttings that present adverse environmental impacts due to the use of certain drilling fluids such as oil-based drilling

fluids (Laroche et al. 2016). These drill cuttings consist of various solid particles from the rocks and liquids released from geological formations from the drill hole. Moreover, toxic and carcinogenic elements of heavy metals and hydrocarbon are contained in these cuttings. The source of these harmful elements is the oil-based drilling fluid and its additives. Due to the presence of these dangerous elements, these cuttings cannot be discharged directly into the environment (Ogechi et

al. 2010). Some techniques were used to treat the drill cuttings before being discharged, e.g., thermal, nano-technology (Bodzek 2022), chemical, solidification/stabilization and bioremediation (Rusin et al. 2021) treatments (Boutamine et al. 2020). Solidification/Stabilization (S/S) commonly applied to the treatment of cuttings due to its significant effectiveness (Ogechi et al. 2010). This Stabilization (or inerting) process involves treating the noxious waste using a hydraulic binder, whereas solidification process of contaminants necessitates the development of a solid mass with sufficient structural integrity to allow transport or storage without using a container (Vehlow 2012). Stabilization/solidification and biological process combination study was investigated by Boutamine et al. (2020). They reported that unconfined compressive strength was significantly affected and also the hydrocarbon was reduced. Previously, a mixture of cement, fly ash, lime and calcium oxide has often been used as a S/S additives for treating drill cuttings and some other types of wet solids (Vehlow 2012). The interactions between a waste and a binder during the S/S technique to develop its effectiveness was investigated using Fourier Transform Infrared (FTIR), Scanning Electron Microscopy (SEM) and Differential Scanning Calorimetry (DSC) technics (Leonard et al. 2010). Comparative study between solidification/stabilization and thermal treatment methods had been also performed by Kherfi et al. (2018). Their results revealed that the S/S method is more effective for eliminating the concentration of heavy metals and organic materials presented in the Algerian drill cuttings. Leonard and Stegemann (2010) added a high carbon fly ash to the Portland cement, as a novel binder, to improve the leachability-related properties of S/S treatment of oil drill cuttings. The results showed that high carbon fly ash improved the immobilization of organic contaminants for S/S of organic drilling wastes. To improve a cement-based solidification/stabilization of a soil contaminated by nitrobenzene, an orthogonal experiment was used by Liu et al. (2012). In their experiment, cement and lime were used as binders; sodium-silicate solution and powder activated carbon were employed as additives. Leaching test and volatilization measurement had been adopted to estimate the efficiency of stabilization/solidification process. Cement based solidification/stabilization for solids wastes treatment has been reported by other researchers elsewhere (Vaccari and Castro 2019).

Despite the efficiency of the reported treatment techniques in the literature, there still persistent need for more development of these technics that treat the harmful petroleum residues before being landfilled to the environment. Normally, landfilling of treated drill cuttings is the last procedure during their management and disposal to the environment. Therefore, it requires paramount treatment and optimization. Furthermore, it is necessary to reduce or to entirely neutralize all the hazardous petroleum residues in these drilling wastes in order to protect the environment.

Herein, we aim to optimize some of the parameters used in the solidification/stabilization treatment of the drill cuttings from Hassi Messaoud oil field. This field is one of the most important fields in Algeria and in the world, because it covers an important quantity of total Crude Oil Production in Algeria of high quality (Light crude oil, API = 45) (Larbi et al. 2015). Moreover, apparently, two-thirds of the Algerian territory is

still mainly underexplored or unexplored. This implies that there are/will be a huge need for more advanced (solidified/stabilized) treatments to neutralize the drilling wastes before their landfilling for more environmental protection because these types of wastes have pollution concentration that exceeds the safety standards significantly. This study has been divided into two main steps:

(i) Determining the impact of the cement as binder and the commonly used additives such as sodium silicate, activated carbon, organophilic clay and sand during the S/S treatment. Also, finding the optimal required quantity for each parameter for effective treatment during S/S process. (ii) Combining the optimal quantities found in the step one to determine the best combination that gives the highest hydrocarbon toxicity reduction from drill cuttings.

The results show that the selected parameters significantly improved the S/S disposal technology for hazardous hydrocarbon removal from drill cuttings. In fact, to the authors' knowledge and according to the literature survey, all previous works, which dealt with S/S technic aiming to neutralize the harmful wastes before their landfilling, were made for other oilfields and only the effect of one or two parameters have been studied. Accordingly, this is the only work that focuses on the optimization of S/S technic by optimizing all important parameters and combining them to extract the best mixture that can make the landfilled cuttings riskiness under the safety standards in Hassi Messaoud oil field, which can be found applicable for other fields.

## Materials and methods

### Materials

#### Sample isolation and characterization

The samples were taken from different places and depths from the same drilling-wastes quagmire, in order to have a representative sample of drill cuttings. Special attention was taken during the sampling process and each sample was homogenized before any further testing. The obtained samples were characterized to determine the exact contents of hazardous materials such as heavy metals and hydrocarbons.

### Additives

#### Sand

Solid sand was used in the experiments and their characterization are mentioned in Table 1.

#### Sodium silicate

The sodium silicate (SS) solution was added to each sample of drill cuttings to reduce the hydrocarbon content and make a better strength of the solidified body.

#### Powder Activated Carbon (PAC)

To improve the efficiency for immobilization of the hydrocarbons in petroleum drill cuttings selected inexpensive thermally regenerated activated carbon has been evaluated.

**Table 1.** Characteristics of solid sand.

Parameters	Cube test sand
Specific gravity	2.65
Bulk density	93.45 lb/ft <sup>3</sup> (1.497 g/cm <sup>3</sup> )

### Organophilic clay

The organophilic clay used in this study was prepared according to the same protocol as that mentioned in reference (Montgomery et al. 1991). The used organophilic clay has the capacity to adsorb organic compounds such as oil from drill cuttings.

### Methods

#### Characterization of Ordinary Portland Cement (OPC)

The mineralogical, chemical and particle size composition of the used hydraulic binder (ordinary Portland cement, OPC) was determined using X-ray diffraction (XRD), X-ray fluorescence analysis (XF) and analysis by Laser Granulometry respectively according to the following conditions:

#### X-ray diffraction (XRD)

PANalytical diffractometer: XPERT-PRO, ceramic X-ray tube with copper anticathode, RX generator power: 40 mA, 45 kV.

Software for data acquisition: PANalytical Data Collector

Data processing software: High Score Plus from PANalytical.

Wavelength  $\text{CuK}\alpha$  [ $\text{\AA}$ ]: 1.5418.

Departure angle  $[2\theta]$ : 2.0000

Final angle  $[2\theta]$ : 70.0000

Step size  $[2\theta]$ : 0.0170

Step time [s]: 91.7599

#### X-ray fluorescence analysis (XF)

The natural sample in powder form was mixed with lithium tetra borate, heated to 1200°C in order to obtain a homogeneous transparent glass (borate pearl) which would be used for the analysis of major elements. The pearl obtained was subjected to a source of primary X-rays. It followed an excitation of the atoms that will emit a secondary X-ray fluorescence characteristic of the chemical composition of the sample analyzed. According to an analysis program previously established on international standards by type of sample, the concentration of the chemical elements making up the sample was determined.

Sequential spectrometers (wavelength dispersive) Bruker-Axs: S8 TIGER.

Rhodium anode.

Software for data processing: Spectra plus.

The concentration of an unknown sample was determined by calibration curves which were plotted for each element after fixing all the measurement parameters (kV-mA, crystal analyzer, collimator, emission wavelength, time and the detector).

#### Analysis by Granulometry Laser

The analysis of the samples was carried out using a LA 950 type laser particle sizer. The distribution statistics have been calculated from the results, using the derivatives  $D [m, n]$ :

$D (v, 0.1)$ ,  $D (v, 0.5)$  and  $D (v, 0.9)$  are standard percentile measures of the analysis.

$D (v, 0.5)$  is the particle size for which 50% of the sample is smaller and 50% of the sample is larger than this size and also known as MMD (Mass Median Diameter).

$D (v, 0.1)$  is the particle size for which 10% of the sample is below this dimension.

$D (v, 0.9)$  is the particle size for which 90% of the sample is below this dimension.

The span is the measure of the width of the distribution, the smaller this value the narrower the distribution. The width is calculated by the following formula:

$$\text{width} = \frac{D(0.9) - D(0.1)}{D(0.5)} \quad (1)$$

### Mixing

Mixing equipment was an electric agitator brand Hamilton Beach. It has a load-bearing axle of a propeller and achieves rotational speeds of 18,000 rpm.

### Oil content in drill cuttings (Hydrocarbon%)

The oil levels in drill cuttings were measured using InfraCal 2 Analyzer. It is a compact, fixed-filter, mid-infrared analyzer with no moving parts.

The analysis procedure involved the following simple steps:

The sample was collected in a container.

The solvent hexane was added to tested sample.

After two minutes' shaking the solvent partitioned, a portion of which was introduced to the infrared analyzer for measurement; the solids were filtered from the solvent prior to testing.

Taking the final results of oil levels (Hydrocarbon%).

### Matrix permeability test

Nitrogen ( $\text{N}_2$ ) gas Permeameter was used to determine the permeability of the treated cylindrical sample, under a pressure of 40 bars. Fig. 1 shows the schematic consisting of the elements of the Permeameter: (2) the head pressure transducer was composed of a pressure sensor and a purge, this part makes it possible to supply the inlet pressure to the sample, (3) the confinement pressure transducer was also formed by a purge and a pressure sensor, and (4) the lower pressure transducer was fitted with a pressure sensor, a flow meter and a tap to control the outlet pressure of the sample (Rosener, 2008). Inlet and outlet pressures were carried out for gas permeability measurements. The applied head pressure can reach 35 bars. The sample sizes were measured, and the permeability was calculated using the Darcy's law; then, it was corrected of the Klinkenberg's effect (Tanikawa and Shimamoto 2006).

### Resistance to free compression (RFC):

The resistance to free compression (RFC) test is carried out for cylindrical samples of 75×150 mm (diameter × height) (Krauthammer et al., 2003). The molds for the test cylinder are made of polished steel or cast iron to avoid adhesion of the cement sample to the sides. Each mold should rest on an adjusted metal base to prevent leaks. The test samples should be stored at a temperature above 10°C. It should be noted that the sample is subjected to this test after treatment, since it is brittle before treatment (zero compressive strength). Thereafter, the solidification of our waste intended for landfilling can be assessed easily.

### Atomic absorption spectrophotometry for the retention of heavy metals

Leaching test allows liquid-solid extraction. In this test, 25 g of the studied sample has been contacted to 250 ml of acidified distilled water (an aqueous solution, PH= 2.88) to simulate acid rain which allowed to the passage of soluble heavy metals to the solution. This is followed by a subsequent separation (filtration), allowing the obtaining of one or more eluent. The eluents are analyzed by the atomic absorption spectrophotometry (AAS) method, which quantifies the

concentrations of heavy metals for drill cuttings before and after solidification/stabilization process.

#### Scanning electron microscopy (SEM)

Scanning electron microscopy was carried out to study the surface morphology of the treated drill cuttings at different times after mixing (curing time). A Supra 40VP Colonne GEMINI Zeiss scanning electron microscope was used, with an accelerating voltage of 15 kV.

#### Acceptance tests of the treated waste

Since the strength test of the treated samples is made for the detection of their stabilization, therefore, after mixing of our samples, the compressive strength was analyzed for several periods: 3, 7, 21, 28 and 96 days.

#### Solid/liquid separation

Solid / liquid separation was obtained using a centrifuge type Megafuge 2.0, marque Heraeus. It can reach the speed of 3500 rpm for a period of 45 minutes.

## Results and discussion

### Characterization of crude drill cuttings

#### Heavy metals and hydrocarbons content

From the results shown in Table 2, the harmful elements that exist in the studied crude cuttings are mostly heavy metals and hydrocarbons. The heavy metals are namely: lead (Pb), copper (Cu), chromium (Cr), cadmium (Cd), zinc (Zn) and manganese (Mn). As it can be seen from this table, there are some samples that have elements of amounts exceeding the maximum tolerated values for hydrocarbons and heavy metals (Khodja, 2008). Thus, the current drill cuttings are conventionally toxic (Lake and Menzies, 2007) and cannot be landfilled and hence further treatments are needed.

### Characterization of Ordinary Portland Cement (OPC)

The mineralogical, chemical and particle size composition of cement has an important role in the properties of solidification/stabilization (S/S). Below are some results:

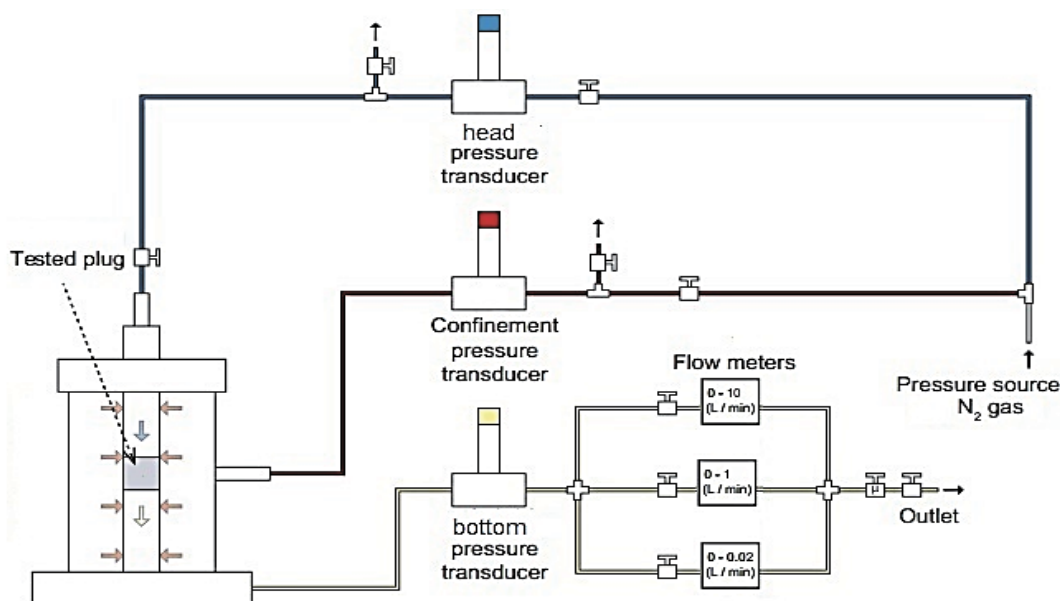

Fig. 1. A diagram showing the Permeameter device using nitrogen gas flow

Table 2. Hydrocarbons and heavy metals contents of the studied crude drill cuttings compared to the maximum conventionally tolerated values

	Heavy metals concentration (mg/l)						Content of hydrocarbons (%)	
	Lead (Pb)	copper (Cu)	chromium (Cr)	Cadmium (Cd)	Zinc (Zn)	manganese (Mn)		
Maximum tolerated values (Khodja,2008), (Abbas, 2011)	1	3	3.1	0.2	5	1	<5%	
Samples	1	32.6	00	00	0.1	8.5	1.8	4.40
	2	46.5	00	0.7	0.1	12.6	2.1	4.00
	3	15.8	1.6	00	00	7.4	1.7	4.65
	4	7.2	00	00	0.1	0.78	1.9	9.61
	5	8.04	00	00	0.1	6.7	1.8	6.56
	6	14.1	00	00	0.2	5.3	1.2	9.40

### Mineralogical analysis

Analysis by X-ray crystallography of the cement sample revealed the mineral phases, namely: Hatrurite  $\text{Ca}_3\text{SiO}_5$ , Brownmillerite  $\text{Ca}_2\text{FeAlO}_5$  and Gypsum  $\text{Ca}(\text{SO}_4)(\text{H}_2\text{O})_2$  (see Fig. 2a).

### X-ray fluorescence analysis

The chemical analysis results of the major elements expressed in percentage by mass (%) are given in Table 3. At the end of these two analyzes we can conclude that the sample is made up of minerals, namely hatrurite and brownmillerite, which are

part of the constitution of cement. In addition, the presence of gypsum is noted in very low concentrations, a level of (CaO) at 64.33%, and the presence of sulfur ( $\text{SO}_3$ ) is also noted at 1.83%.

### Granulometric distribution

The composition and the grain size of the cement has a big role in the mechanical and retention properties of Hydrocarbon (HC). The particle size analysis revealed the presence of two particle size ranges for Portland cement. The grain size

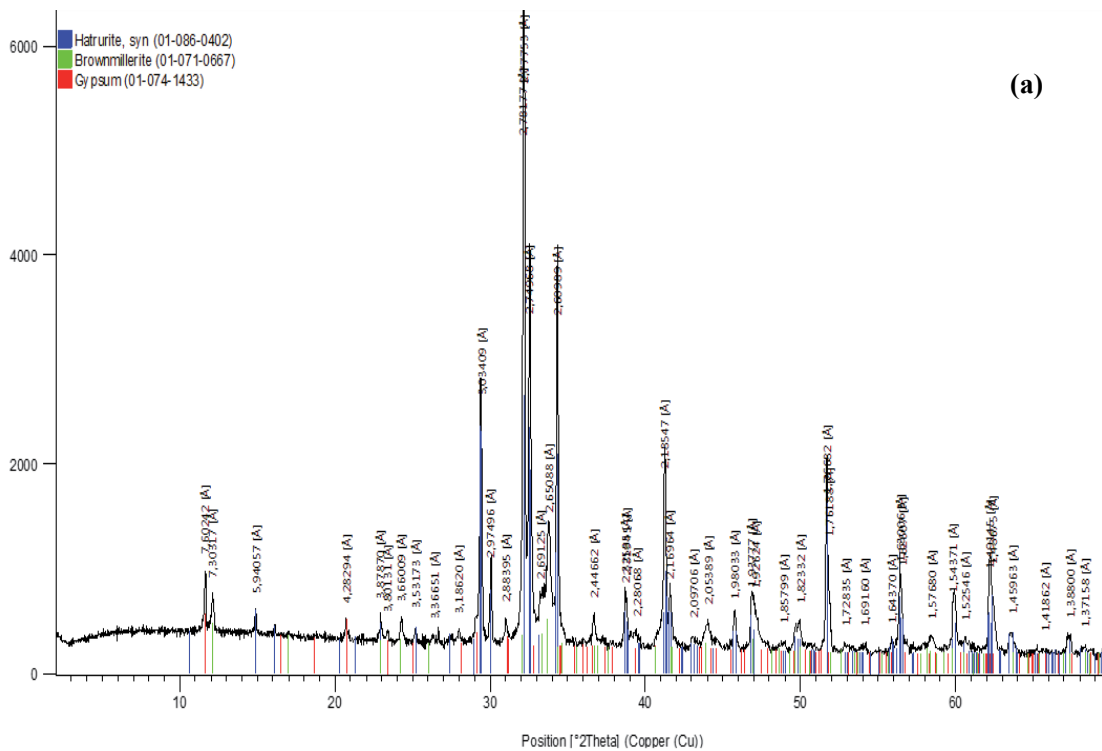

Name: Cement-Lafarg		Median diameter	: 15.68481 Microns	Geo. Variance	: 1.3184 Microns <sup>2</sup>
Average Diameter	: 31.09592 Microns	Geo. Diameter for cumulative %	:	D(v. 0.1)	: 8.38354 Microns
Variance	: 3847.5 Microns <sup>2</sup>	D(v. 0.5)	: 15.68481 Microns	D(v. 0.9)	: ns
Standard deviation	: 62.0282 Microns	Geo. standard deviation	:		ns
Diameter mode	: 14.2345 Microns				
Span	: 1.7119				
Average geo. Diameter	: 17.8192 Microns				

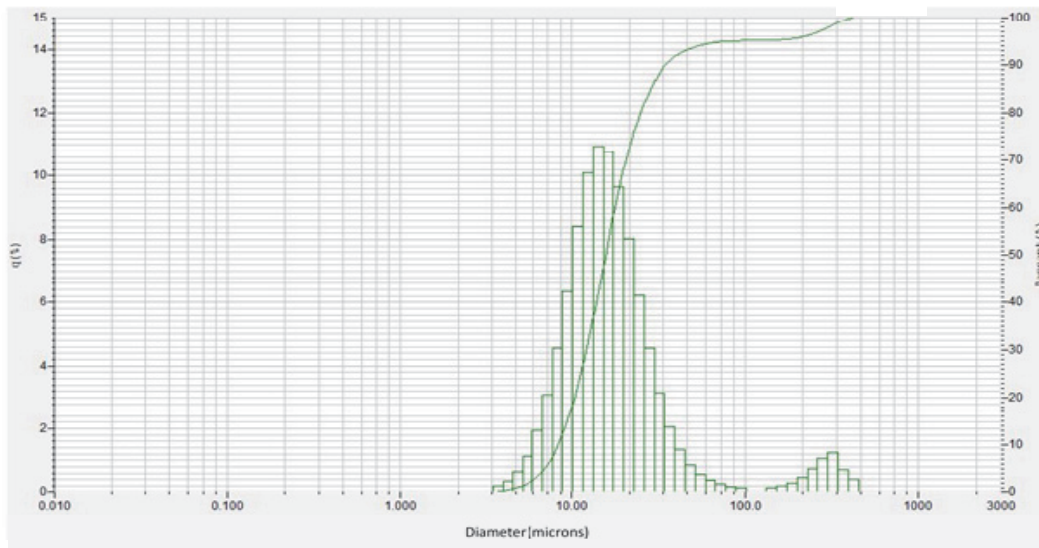

Fig. 2. a. diffractogram of the cement sample, b. Histogram of the different particle size phases of the cement

population varies between 3.90 and 451.55  $\mu\text{m}$  with a median size of 15.68  $\mu\text{m}$ . The Fig 2.b shows the distribution histogram of different particle size phases of the cement. The laser particle size measurement results for OPC were detailed in Table 4.

### Solidification/Stabilization parameters improvement Effect of Cement

In all experiments, sample 5 in Table 5 was chosen for the test because it has a higher oil level (Oil%=9.61). This crude sample is considered as a reference sample (RS). Table 5 depicts the hydrocarbons' concentration with different ratios of cement-to-drill cuttings ( $C_{\text{cement}}$ ). The ratios were (0.02:1), (0.04:1), (0.06:1), (0.09:1), (0.11:1), and (0.13:1). As it can be seen, the hydrocarbons' concentration is inversely proportional to the concentration of  $C_{\text{cement}}$ . The cement concentration was effective in reducing hydrocarbon concentration from the drill cuttings up to (0.09:1). Increasing the cement concentration beyond (0.09:1) has no significant effect on the hydrocarbon reduction. Therefore, economically, the ratio of (0.09:1) cement-to-drill cuttings can be chosen as the optimal amount, to reduce the

hydrocarbons concentration from the drilling cuttings obtained from Hassi Messaoud oil field. The rise in cement concentration above (0.09:1) led to the formation of a solid matrix which strengthens the encapsulation process. Consequently, large amounts of hydrocarbons are removed with addition of an optimized concentration of cement (Zhang and Bishop, 2002).

### Sand addition effect

Table 5 illustrates the hydrocarbons percentage for different concentrations of sand. It is noticeable that the addition of sand reduces hydrocarbon ratio within the selected sample (RS). The hydrocarbon ratio diminished gradually from 9.61% to 5.21% after adding (0.04:1) sand-to-drill cuttings. This was expected since adding sand to the mixture improves cohesion, because the sand contributes to a good granular gradient, and from there, a balanced distribution of cement and additives inside the mixture (Belferra et al., 2016)  $d = 0.28$  mm. The ratio (0.04:1) is considered as optimal concentration of sand because after this amount of sand (0.04:1), the decrease in the hydrocarbon content is very low (0.13%).

**Table 3.** Elementary chemical composition of OPC expressed in percentage by mass (%)

Chemical elements (%)																
N°	Designation	SiO <sub>2</sub>	Al <sub>2</sub> O <sub>3</sub>	Fe <sub>2</sub> O <sub>3</sub>	CaO	MgO	Mn <sub>2</sub> O <sub>3</sub>	Na <sub>2</sub> O	K <sub>2</sub> O	P <sub>2</sub> O <sub>5</sub>	TiO <sub>2</sub>	SO <sub>3</sub>	SrO	Cr <sub>2</sub> O <sub>3</sub>	ZnO	TOT
1	Sample 03	21.19	4.58	6.13	64.33	1.28	0.03	0.14	0.34	0.19	0.19	1.83	0.30	0.009	0.047	100.59

**Table 4.** Laser particle size measurement results for OPC

Number	Diameter (Microns)	Passing q (%)	Cumulative Passing (%)
74	229.075	0.432	95.999
75	262.376	0.71	96.708
76	300.518	1.032	97.74
77	344.206	1.212	98.952
78	394.244	0.674	99.626
79	451.556	0.374	100
80	517.2	0	100

**Table 5.** The hydrocarbons concentration with the different ratios of parameters-to-drill cuttings

Parameters	Concentrations											
Cement concentration	(RS)	0.02:1	0.04:1	0.06:1	0.09:1	0.11:1	0.13:1	/	/	/	/	/
Hydrocarbon content (%)	9.61	7.02	6.84	6.75	6.56	6.54	6.52	/	/	/	/	/
Sand concentration	(RS)	0.009:1	0.018:1	0.02:1	0.03:1	0.04:1	0.05:1	0.06:1	0.07:1	0.08:1	0.09:1	
Hydrocarbon content (%)	9.61	6.11	5.81	5.49	5.44	5.21	5.19	5.14	5.12	5.11	5.08	
Sodium silicate concentration	(RS)	0.003:1	0.006:1	0.009:1	0.012:1	0.015:1	/	/	/	/	/	/
Hydrocarbon content (%)	9.61	7.8	6.56	6.54	6.52	6.51	/	/	/	/	/	/
Activated carbon concentration	(RS)	0.004:1	0.009:1	0.013:1	0.018:1	0.022:1	0.027:1	/	/	/	/	/
Hydrocarbon content (%)	9.61	6.9	6.25	5.88	6.48	6.23	6.75	/	/	/	/	/
Organophilic clay concentration	(RS)	0.004:1	0.009:1	0.013:1	0.018:1	0.022:1	0.027:1	/	/	/	/	/
Hydrocarbon content (%)	9.61	7.49	6.75	6.25	6.48	6.85	7.00	/	/	/	/	/

### Sodium silicate effect

To determine the effect of sodium silicate concentration ( $C_{si}$ ) on hydrocarbons' removal, different sodium silicate-drill cuttings ratios were tested. As it can be seen from Table 5, the reduction of hydrocarbons percentage due to  $C_{si}$  addition was significant until the ratio (0.006:1) of sodium silicate: drill cuttings. After this ratio, there is almost no change in hydrocarbons content. Sodium silicate that was mixed with Portland cement improved mechanical properties such as the strength of materials (Wang et al., 2019).

### Activated carbon effect

The effect of adding activated carbon on hydrocarbon concentration reduction is shown in Table 5. It is evidenced that the hydrocarbons' content decreases until 5.88% after the ratio (0.013:1) of (activated carbon: drill cuttings). However, the hydrocarbons' content starts to increase beyond this ratio of activated carbon: drill cuttings. This explains that the activated carbon is considered as adsorbent of hydrocarbons (Arafat et al., 1999). The adsorption of hydrocarbon on activated carbon is much faster until (0.013:1). It can be seen that the Table 5 contains an optimum concentration of activated carbon that should not be exceeded to avoid the release of hydrocarbons.

### Organophilic clay effect

Table 5 shows the effect of adding organophilic clay for hydrocarbons removal. A gradual degradation of hydrocarbons is noticed with increasing the ratio of (organophilic clay : drill cuttings) until it reaches (0.013:1), which corresponds to a hydrocarbon content reduction of 6.25%. After this ratio, the rate of hydrocarbons starts to increase again. Therefore, this ratio value is considered as the optimal value of organophilic clay and should not be exceeded so as not to have the opposite effect for this specific type of drill cuttings. This phenomenon is justified by two reasons: firstly, the clay is fragile, and this property affects the solidification of the treated samples matrix – when a certain concentration is exceeded, the contaminants will be released; secondly, (0.013:1) of clay decreases the percentage of hydrocarbons to 6.25%, which promotes the dispersion of non-adsorbed oily particles in the treated samples. The importance of the adsorbent of organophilic clay, either as a pre-treatment or as an additive, actually promotes the immobilization of the contaminants in the solidified-stabilized waste (Paria and Yuet, 2006).

### Combination of optimum ratios

In the previous section, the optimum parameters of solidification/stabilization treatment were determined. The optimum concentrations' results were for the cement-to-drill cuttings mass ratio (0.09:1). For the additives-to-drill cuttings, the mass ratios are (0.04:1), (0.006:1), (0.013:1) and (0.013:1) for the sand, sodium silicate, organophilic clay and activated carbon, respectively. At this stage, we aim to combine the last optimum results. Several mixtures were formulated in order

to obtain the optimum formula. This involved the use of the obtained optimal concentrations of the tested parameters and the following mixtures were tested:

Cuttings + optimum of cement + optimum of sodium silicate = Mixture A

Cuttings + optimum of cement + optimum of activated carbon = Mixture B

Then, the optimal quantity of the sand is added to the aforementioned mixtures:

Cuttings + optimum of cement + optimum of sodium silicate + optimum of sand = Mixture C

Cuttings + optimum of cement + optimum of activated carbon + optimum of sand = Mixture D

Cuttings + optimal cement + optimal organophilic clay + optimal sand = Mixture E

Table 6 summarizes the results of these combinations on the hydrocarbon content within the studied sample. The mixture D with the activated carbon as adsorbent gave the best result, then that with the sodium silicate (mixture C). These results are confirmed by other research results that have used the activated carbon as adsorbent for hazardous wastes' treatment (Arafat et al. 1999) and in another for decomposition and remediation of hazardous organic materials (Zhang and Bishop 2002, Rho et al. 2001).

The results recorded in Table 6 showed that sand improves the retention of hydrocarbons in both combinations. Because it strengthens the matrix formed by the cement, which in turn gives the treated waste a better solidification. Moreover, the sand effect is more pronounced with sodium silicate (Mixture C) than that with activated carbon (Mixture D). For the same amount of sand, a decrease of 1.25% of hydrocarbons rate is obtained with sodium silicate, whereas, only a decrease of 0.62% of hydrocarbons with activated carbon is found. From the obtained results, sodium silicate (Mixture C) is selected to be treated with more stabilizers (optimal amounts) i.e., organophilic clay and activated carbon, as follows:

Cuttings + optimum of cement + optimum of sand + optimum of sodium silicate + optimum of organophilic clay = Mixture F.

cuttings + optimum of cement + optimum of sand + optimum of sodium silicate + optimum of activated carbon = Mixture G.

Table 7 summarizes the results of these new combinations. From these results, the combination of an adsorbent with an encapsulant improves the results obtained in the samples stabilized by adsorption. Nevertheless, this decrease is not very important compared with the results obtained in the samples without combinations of stabilizers.

### Centrifugation Effect and Acceptance Test For Landfilling

The optimized results using (Mixture G, 5.102%) are still insufficient for the landfilling, since they possess values that are above the tolerated value which is 5% (Abbas, 2011). Thus, for the solidification/stabilization process for drill cuttings

**Table 6.** Combinations results of optimums of stabilizers with optimums of sand and cement

Samples compositions	(RS)	Mixture A	Mixture B	Mixture C	Mixture D	Mixture E
Hydrocarbon content (%)	9,61	6,482	5,811	5,227	5,191	6.250

highly contaminated with hydrocarbons, to be effective, the cuttings must be subjected to the pre-treatment (centrifugation, dilution) operation to confirm the regulations set by SONATRACH (Khodja 2008, Abbas 2011). The results of the sample before (Mixture G) and after centrifugation operation (Mixture  $\bar{G}$ ) are presented in Table 8. From this table, it is found that the hydrocarbon content of our centrifuged sample dropped from 5.102 to 1.999%, which meets the standards set by SONATRACH (mass percentage of hydrocarbon less than or equal to 5%) (Abbas 2011).

So, it can be declared that the sample of mixture at this rate of 1.999% of hydrocarbon content had successfully passed the acceptance test for landfilling (in what concerns the amount of hydrocarbons).

#### Matrix Permeability

After the analysis, the permeability of the treated sample is 59.71 mD. The treatment by solidification/stabilization gives a good result, because the cement fills the void that exists between the particles (contaminated with hydrocarbon) of a sample before treatment and solidifies it. Therefore, it makes the fluid passage within the matrix difficult. The solidification/stabilization effectiveness was confirmed by Ogechi et al. (2010).

#### Matrix Solidification Test: Resistance to Free Compression (RFC)

Fig 3a shows the compressive strength of the treated sample during curing time. It can be noticed that the curing of the

sample increases with time, i.e., 84.24, 139.18, 186.39, 211.88 and 246.04 (kg/cm<sup>2</sup>) after 3, 7, 21, 28 and 96 days, respectively. The Strength test is used to provide a comparison between stabilized and unstabilized drill waste cuttings (Malviya and Chaudhary 2006). Hence, it can be deduced that the proposed treatment criteria using the solidification/stabilization method improves the mechanical properties of the drilling waste. The EPA (United States Environmental Protection Agency) Guide considered that 0.35 MPa is the value to have a satisfactory compressive strength ("Guide to disposal of chemically stabilized and solidified wastes," 1982). This value (0.35 Mpa) has been proposed as a minimum value for materials to be landfilled. Accordingly, this confirms that our treated cuttings are very acceptable for landfilling. Compressive strength was tested at different times by Malviya and Chaudhary (Malviya and Chaudhary 2004). They reported that compressive strength increases as the curing time increases (Malviya and Chaudhary 2006). However, many other factors affect the effectiveness of solidification/stabilization such as cuttings nature and its properties, waste/cement ratio, type of cement, curing days, etc. (Malviya and Chaudhary 2004, Malviya and Chaudhary 2006).

#### Stabilization Tests of the Treated Waste

##### Atomic absorption spectrophotometry for the retention of heavy metals

Table 9 presents the results of Atomic Absorption Spectrophotometry Analysis (AAS) of the waste sample before and after treatment, compared to the maximum tolerated

**Table 7.** Combinations results of the optimums of adsorbent with the optimum of sodium silicate, cement and sand

Samples compositions	(RS)	Samples with combinations of Stabilizers	
		Mixture F	Mixture G
Hydrocarbon content (%)	9.61	5.124	5.102

**Table 8.** Results before and after centrifugation of the optimal mixture

Sample	before centrifugation "Mixture G"	after centrifugation "Mixture "
Hydrocarbon content (%)	5.102	1.999

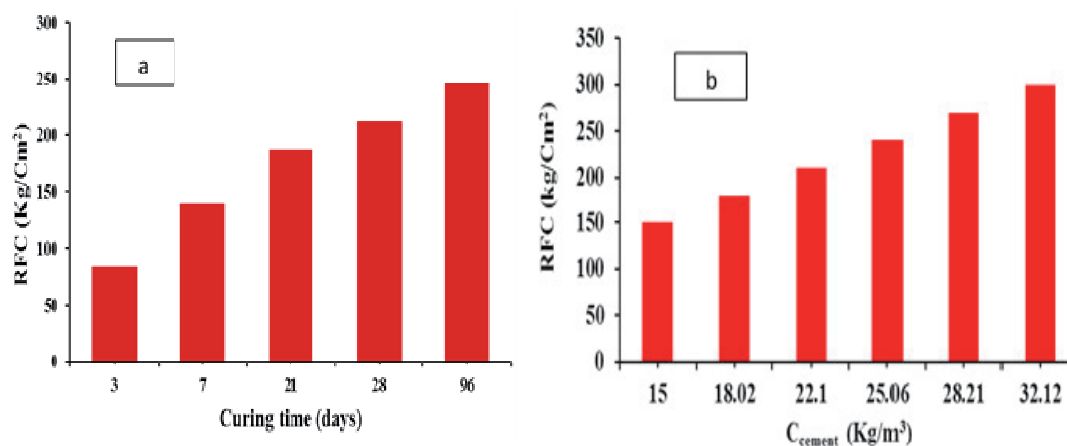

**Fig. 3a.** Resistance to free compression as a function of the curing days. **b.** Variation in mechanical strength as a function of the concentration of cement.



values for the landfilling. From the results recorded in Table 9, it can be seen that the solidification/stabilization treatment is very effective for heavy metals elimination (Ogechi et al. 2010). Moreover, after treatment, the results show that the concentrations of all elements in the final sample are below the safety standards (below the maximum tolerated values) where only some traces of Zn was remained. This confirms that our treated sample strongly passes the leaching test.

#### Acceptance Test of the Treated Waste for Recovery

Fig. 3b represents the variation of the resistance to free compression as a function of the cement concentration after 7 curing days. According to Fig. 3b, the resistance to free compression (RFC) of our treated sample increases with increasing cement content, which surpasses the allowed minimum value (0.35 MPa), (“Guide to disposal of chemically stabilized and solidified wastes,” 1982), by many times. It is deduced from this test that the pre-treated sample was very brittle, so, the production of concrete from the treated waste requires the addition of considerable quantities of cement. The cement offers a sturdy structure to the treated sample and binds well the harmful heavy metals and prevents their movement in a monolithic mass (Masrullita et al., 2018).

#### Shape and Morphology of the Treated Drill Cuttings

To discuss the effects of the solidification/stabilization process on the treated drill cuttings, it is important to investigate the surface morphology before landfilling. Figs. 4a,b, and c show the images of the treated drill cuttings at different times after mixing for: 7, 28, and 96 days respectively, obtained using the SEM technic. The SEM structure indicates that the samples consist of granules of clay materials, with silicon as the predominant component. They also show high levels of carbon (HC), calcium hydroxide, C-SH, and some aggregates of grain-like. Therefore, it can be concluded that the time

after mixing has no effect on the sample morphology but rather had an effect on hardness and durability of the sample. Furthermore, the shapes and surfaces of the three obtained samples indicate that the sample C is more solid and stable compared to the other samples. This later result was confirmed by the results of compressive strength which is proportional to the curing time because the porosity has an impact on the strength (Wang et al. 2019). The tests have also revealed that the final stabilized outcome of Portland cement is a concrete of low permeability sturdy compact matrix related to liquid substances (hydrocarbons) (Clark and Perry 1985, Poon et al. 1985, Zhao et al. 1999, Lake and Menzies 2007), which offer an appropriate pore arrangement for storing the substances within it (Young 1992). These facts clarify the reason of the very low amounts of heavy metals for the sample after S/S treatment found in Table 9.

#### Conclusion

The solidification/stabilization (S/S) process can be used to treat the majority of industrial wastes. Overall, the final wastes which cannot undergo an energy or material recovery can be treated by the S/S process. The effectiveness of the treatment depends mainly on the mechanical properties of the cement and particularly its resistance to compression. Environmental protection is paramount in the whole world. These polluting discharges must undergo a solidification/stabilization treatment to avoid any contamination of the soil and subsoil. To overcome this problem, the national and international laws concerning the environment and the treatment of discharges (solid and liquid) must be strictly applied and respected.

In this study, aiming at making the Algerian petroleum drill cuttings waste extracted from Hassi Messaoud oil field inert and to immobilize the heavy metals and hydrocarbons contained within it an optimization study using S/S treatment is

**Table 9.** Results of atomic absorption spectrophotometry

Heavy Metals	Cd	Cr	Pb	Mn	Cu	Zn
maximum tolerated values (mg/l) (Abbas, 2011)	0.2	3.1	1	1	3	5
Before treatment (mg/l)	0.1	0	7.2	1.9	0	0.78
After treatment (mg/l)	0	0	0	0	0	0.13

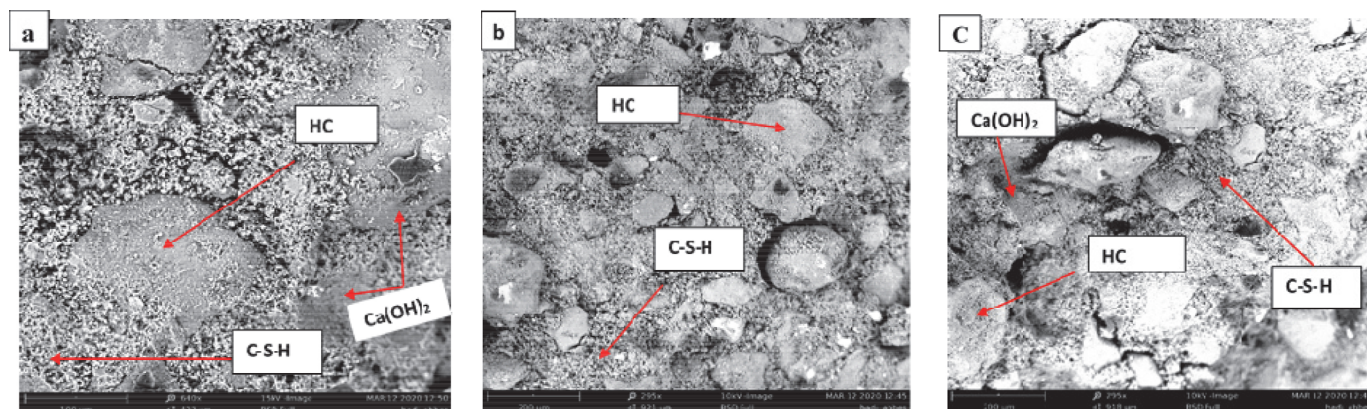

**Fig. 4.** SEM images for treated drill cuttings. (a) 7days after mixing (b) 28 days after mixing (C) 96 days after mixing

made. This is achieved by revealing the optimum concentration of the five most commonly used elements in the S/S treatment (cement as hydraulic binder, sand, sodium silicate, organophilic clay and activated carbon as additives). In the second stage, the mixing of these optimum concentrations together has been conducted to uncover the optimum formula that gives the best results for the disposal of this type of organic wastes.

Based on the results obtained from this study, the S/S treatment by the addition of cement and sodium silicate has been proven to be very effective. The optimum concentrations were found to be (0.09:1), (0.04:1), (0.006:1), (0.013:1) and (0.013:1) for the cement, sand, sodium silicate, organophilic clay and activated carbon, respectively. The combination of these optimums was evaluated to obtain an excellent result of the treated drill cuttings for landfilling. The obtained results show that the hydrocarbon content of our sample, dropped from 9.40 to 1.999% which fits very well the safety standards. Besides that, the treated drilling waste has successfully passed the leaching and mechanical tests after its treatment where only some traces of Zn were found after treatment (0.13). The analysis and the results of our samples before and after the S/S treatment have been evaluated and ensured by advanced means and methods such as: SEM, AASA, RFC, centrifugation. In the light of the obtained results, it can be declared that the treated waste can be recovered and reutilized in some construction application such as road construction and pavement.

## Acknowledgements

The authors are grateful to the SONATRACH National Oil Company in Algeria. Also, the Department of Oil Drilling in Kasdi Merbah University, and Department of Chemical and Petroleum Engineering at the University of Calgary is greatly appreciated. A special acknowledgement to Mr. Aiad Lahcen for his help.

## References

- Abbas, A.H. (2011). Les bourbiers de forages pétroliers et des unités de production: Impact sur l'environnement et technique de traitement. Kasdi Merbeh Ouargla.
- Arafat, H.A., Hebatpuria, V.M., Rho, H.S., Pinto, N.G., Bishop, P.L. & Buchanan, R.C. (1999). Immobilization of phenol in cement-based solidified/stabilized hazardous wastes using regenerated activated carbon: Role of carbon. *J. Hazard. Mater.* 70, 139–156. DOI: 10.1016/S0304-3894(99)00127-2
- Belferra, A., Kriker, A., Abboudi, S. & Bi, S.T. (2016). Effect of granulometric correction of dune sand and pneumatic waste metal fibers on shrinkage of concrete in arid climates. *J. Clean. Prod.* 112, 3048–3056. DOI: 10.1016/j.jclepro.2015.11.007
- Bodzek, M. (2022). Nanoparticles for water disinfection by photocatalysis: A review. *Archives of Environmental Protection*, 48, 1, pp. 3–17, DOI: 10.24425/aep.2022.140541
- Boutamine, H., Salem, Z. & Khodja, M. (2020). Petroleum drill cuttings treatment using stabilization/solidification and biological process combination. *Soil Sediment Contam.* 29, 369–383. DOI: 10.1080/15320383.2020.1722982
- Clark, A.I. & Perry, R. (1985). Cement-Based Stabilization/Solidification Processes for the disposal of toxic wastes. Proceedings from a Workshop on Environmental Technology Assessment. Beaumont, PWR, Jain, RK and Engelbrecht, RS, Eds. pp. 1–44.
- Coz, A., Andrés, A., Soriano, S., Viguri, J.R., Ruiz, M.C. & Irabien, J.A. (2009). Influence of commercial and residual sorbents and silicates as additives on the stabilisation/solidification of organic and inorganic industrial waste. *J. Hazard. Mater.* 164, 755–761. DOI: 10.1016/j.jhazmat.2008.08.079
- Guide to disposal of chemically stabilized and solidified wastes, 1982. U.S EPA SW872. DOI: 10.1016/0016-2361(79)90171-6
- Kherfi, A. & Ganoune, L. (2018). Etude de l'efficacité des méthodes de traitement de boue de forage appliquée. Memoire de licence, Université Kasdi Merbeh Ouargla.
- Khodja, M. (2008). Les Fluides De Forage : Etude Des Performances Et Considerations Environnementales 198.
- Krauthammer, T., Elfahal, M.M., Lim, J., Ohno, T., Beppu, M. & Markeset, G. (2003). Size effect for high-strength concrete cylinders subjected to axial impact. *Int. J. Impact Eng.* 28, 1001–1016. DOI: 10.1016/S0734-743X(02)00166-5
- Lake, C.B. & Menzies, T. (2007). Assessment of two thermally treated drill mud wastes for landfill containment applications. *Waste Management & Research: The Journal for a Sustainable Circular Economy* 394–401. DOI: 10.1177/0734242X07073652
- Larbi, A., Daaou, M. & Faraoun, A. (2015). Investigation of structural parameters and self-aggregation of Algerian asphaltens in organic solvents. *Pet. Sci.* 12, 509–517. DOI: 10.1007/s12182-015-0041-x
- Laroche, O., Wood, S.A., Tremblay, L.A., Ellis, J.I., Pawlowski, J., Lear, G., Atalah, J. & Pochon, X. (2016). First evaluation of foraminiferal metabarcoding for monitoring environmental impact from an offshore oil drilling site. *Mar. Environ. Res.* 120, 225–235. DOI: 10.1016/j.mrenvres.2016.08.009
- Leonard, S.A., Roy, A.D. & Stegemann, J.A. (2010). Stabilization/solidification of petroleum drill cuttings: Thermal and microstructural studies of binder hydration products. *Environ. Eng. Sci.* 27, 889–903. DOI: 10.1089/ees.2010.0147
- Leonard, S.A. & Stegemann, J.A. (2010). Stabilization/solidification of petroleum drill cuttings: Leaching studies. *J. Hazard. Mater.* 174, 484–491. DOI: 10.1016/j.jhazmat.2009.09.078
- Liu, J., Nie, X., Zeng, X. & Su, Z. (2012). Cement-based solidification/stabilization of contaminated soils by nitrobenzene. *Front. Environ. Sci. Eng. China* 6, 437–443. DOI: 10.1007/s11783-012-0406-y
- Malviya, R. & Chaudhary, R. (2006). Factors affecting hazardous waste solidification/stabilization: A review. *J. Hazard. Mater.* 137, 267–276. DOI: 10.1016/j.jhazmat.2006.01.065
- Malviya, R. & Chaudhary, R. (2004). Study of the treatment effectiveness of a solidification/stabilization process for waste bearing heavy metals. *J. Mater. Cycles Waste Manag.* 6, 147–152. DOI: 10.1007/s10163-004-0113-2
- Masrullita, Perry Burhan, R.Y. & Trihadiningrum, Y. (2018). Stabilization/solidification of waste containing heavy metals and hydrocarbons using OPC and land trass cement. *J. Ecol. Eng.* 19, 88–96. DOI: 10.12911/22998993/92926
- Montgomery, D.M., Sollars, C.J., Perry, R., Tarling, S.E., Barnes, P. & Henderson, E. (1991). Treatment of Organic-Contaminated Industrial Wastes Using Cement-Based Stabilization/Solidification – II. Microstructural Analysis of the Organophilic Clay as a Pre-Solidification Adsorbent. *Waste Manag. Res.* 9, 113–125. DOI: 10.1177/0734242X9100900116
- Ogechi Opete, S.E., Ibifuro, A.M. & Elijah, T.I. (2010). Stabilization/solidification of synthetic Nigerian drill cuttings. *African J. Environ. Sci. Technol.* 4, 149–153. DOI: 10.5897/ajest09.012
- Paria, S. & Yuet, P.K. (2006). Solidification-stabilization of organic and inorganic contaminants using portland cement: A literature review. *Environ. Rev.* 14, 217–255. DOI: 10.1139/A06-004
- Poon, C.S., Peters, C.J. & Perry, R. (1985). Mechanisms of Metal Stabilization by Cement Based Fixation Processes. *Sci. Total Environ.* Elsevier Holland pp. 55–71.

- Rho, H., Arafat, H.A., Kountz, B., Buchanan, R.C., Pinto, N.G. & Bishop, P.L. (2001). Decomposition of hazardous organic materials in the solidification/stabilization process using catalytic-activated carbon. *Waste Manag.* 21, 343–356. DOI: 10.1016/S0956-053X(00)00080-5
- Rosener, M. (2008). Etude pétrophysique et modélisation des effets des transferts thermiques entre roche et fluide dans le contexte géothermique de Soultz-sous-Forêts. To cite this version : HAL Id : tel-00202959 Etude pétrophysique et modélisation des effets des transferts.
- Rusin, M., Gospodarek, J. & Nadgórska-Socha, A. (2021). Time-delayed effect of petroleum-derived products in soil and their bioremediation on plant – herbivore interaction. *Archives of Environmental Protection*, 47, 3, pp. 71–81, DOI: 10.24425/aep.2021.138465
- Tanikawa, W. & Shimamoto, T. (2006). Klinkenberg effect for gas permeability and its comparison to water permeability for porous sedimentary rocks. *Hydrol. Earth Syst. Sci. Discuss.* 3, 1315–1338. DOI: 10.5194/hessd-3-1315-2006
- Vaccari, M. & Castro, F.D. (2019). Non-conventional stabilisation/solidification treatment of industrial wastes with residual powdered paints. *Waste Manag. Res.* 37, 1012–1024. DOI: 10.1177/0734242X19860178
- Vehlow, J. (2012). Reduction of dioxin emissions from thermal waste treatment plants: A brief survey. *Rev. Environ. Sci. Biotechnol.* 11, 393–405. DOI: 10.1007/s11157-012-9296-5
- Wang, Z., Sun, Y., Zhang, S. & Wang, Y. (2019). Effect of sodium silicate on Portland cement/calcium aluminate cement/gypsum rich-water system: Strength and microstructure. *RSC Adv.* 9, 9993–10003. DOI: 10.1039/c8ra09901d
- Yoon, S., Bhatt, S.D., Lee, W., Lee, H.Y., Jeong, S.Y., Baeg, J.O. & Lee, C.W. (2009). Separation and characterization of bitumen from Athabasca oil sand. *Korean J. Chem. Eng.* 26, 64–71. DOI: 10.1007/s11814-009-0011-3
- Young, J.F. (1992). Dense High Strength, Low Permeability Cement Based Materials for Containment. Proc. 1st Intl Symposium, Cement Industry Sol. to Waste Mgt, Canadian Portland Cement Assoc. Toronto pp. 13–22.
- Zhang, J. & Bishop, P.L. (2002). Stabilization/solidification (S/S) of mercury-containing wastes using reactivated carbon and Portland cement. *J. Hazard. Mater.* 92, 199–212. DOI: 10.1016/S0304-3894(02)00019-5
- Zhao, T., Zhu, J. & Chi, P. (1999). Modification of Pore Chemicals in evaluation of High-Performance Concrete Permeability. *ACI Mater. J.* 96: 84–89.