

# Initial Realization of a Sensor Fusion Based Onboard Maritime Integrated PNT Unit

R. Ziebold, Z. Dai, L. Lanca, T. Noack & E. Engler

*Institute of Communications and Navigation, German Aerospace Centre (DLR), Neustrelitz, Germany*

**ABSTRACT:** This paper introduces the basic concept of the Position Navigation and Timing (PNT) Module as future part of a ship side Integrated Navigation System (INS). Core of the PNT Module is a sensor fusion based processing system (PNT Unit). The paper will focus on important aspects and first results of the initial practical realization of such a PNT Unit, including a realization of a Consistent Common Reference System (CCRS), GNSS/IMU tightly coupled positioning results as well as contingency performance of the inertial sensors.

## 1 INTRODUCTION

Position fixing systems are considered as a strategic key element of the International Maritime Organizations (IMO) e-Navigation strategy [1]. The improvement and the indication of reliability have been identified as high level user needs with respect to electronic position fixing [2]. Analyzing reliability of position and other PNT parameters of a vessel, not only the ship-side components but the whole integrated PNT system needs to be considered [3]. The generic architecture of the maritime integrated PNT System is shown in Fig. 1. It is the sum of satellite-based, ashore and aboard components and its related links.

Only the integrated use of these components enables the provision of position, navigation and time information taking into account different requirements on accuracy and reliability coming from different maritime applications.

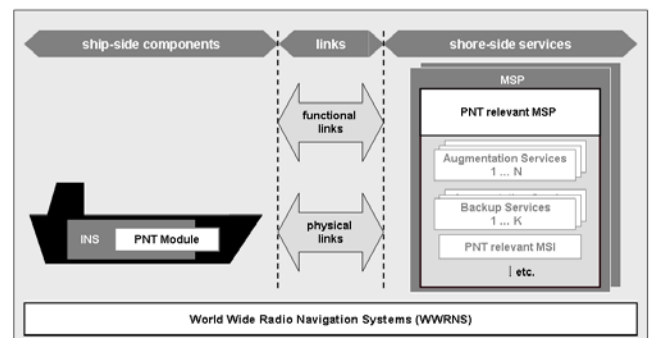

Figure 1. Generic architecture of the Integrated PNT System

Existing and future World Wide Radio Navigation Systems (WWRNS) like GPS, GLONASS and GALILEO are fundamental infrastructures for global determination of position, navigation and timing data. Additionally, shore-side services as part of the Maritime Service Portfolio (MSP) are used or considered as candidates to improve the positioning performance (augmentation services: e.g. IALA Beacon DGNSS, RTK), to support the backup functionality (backup services: e.g. e-LORAN, R-

Mode), or to provide PNT relevant Maritime Safety Information (MSI: e.g. service level, tidal information).

In our concept, a PNT Module as one part of a future INS will be responsible for the provision of PNT information to the shipborne user (see Fig. 1). Core of this PNT Module is a PNT Unit, which uses the available navigation and augmentation signals in combination with additional data of sensors aboard to provide accurate and robust PNT information of the ship [4].

This paper concentrates on this ship-side part of the maritime integrated PNT System. Section II provides an overview of the current PNT system and shortly introduces our concept of an on-board maritime PNT Module. In section III, which is the main part of the paper, results of the initial practical realization of a PNT Unit will be presented.

## 2 PNT MODULE CONCEPT

### 2.1 Overview

A detailed discussion of our PNT Module concept can be found in [4], here only a short overview will be given. Currently, vessels subject to the International Convention for the Safety of Life at Sea (SOLAS) [5] can either use single sensors to provide the PNT parameters (e.g. position, heading, speed over ground) individually or use an INS [6]. Fig. 2. represents the single sensor approach. Stand-alone equipment provides only sensor-specific PNT data e.g. WWRNS sensors for position, velocity and time data (PVT) and other ship-side sensors for navigation data (N). The shipboard processing layer is part of the applied sensors and represents the internal used methods for the provision of respective PNT data. The onboard staff has to fuse and assess the navigational data coming from the different sensors.

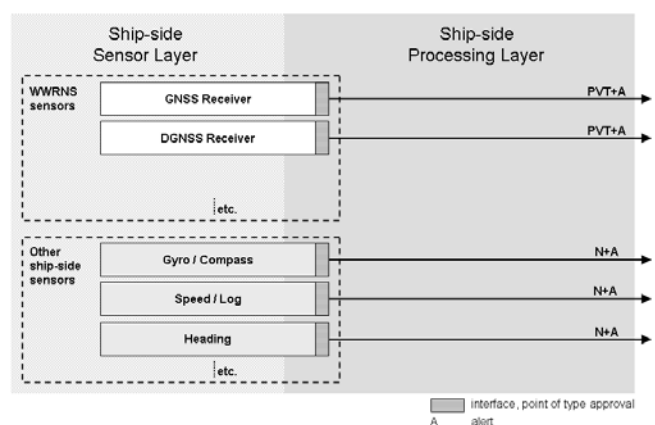

Figure 2. Single sensor approach

In the current INS approach, the sensors deliver their individually determined PNT data to a shipboard processing layer, which is illustrated in Fig. 3. The INS is performing plausibility checks on the incoming data and consistency checks on different sensors utilizing the redundancy within the applied INS. Integrity, as defined in this current INS standard, is expected, if plausibility and consistency checks are passed [7].

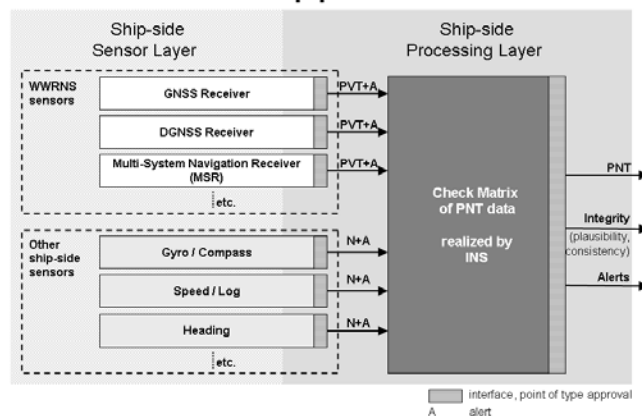

Figure 3. Approach of current INS

Due to the fact, that not all possible failure modes can be detected, plausibility and consistency tests alone are insufficient to guarantee the reliability of INS outputs (see discussion in [4]).

In order to solve these problems identified above, a PNT data processing unit (short: PNT Unit) is introduced into the shipboard processing layer of a future INS, as illustrated in Fig. 4. By means of sensor fusion techniques, this PNT Unit integrates all available PVT and N data from onboard sensors in order to provide optimal PNT output data. In addition to the current INS approach, the onboard sensors (here especially the GNSS Receivers) should also provide their raw data (e.g. ephemerids, code, doppler and phase measurements) to the PNT Unit. This enables the usage of advanced sensor fusion techniques and enhanced integrity monitoring functions in order to improve the resilience of PNT information. As a new functionality, the PNT Unit will not only provide optimal estimations of the PNT output data but also integrity information based on accuracy estimations.

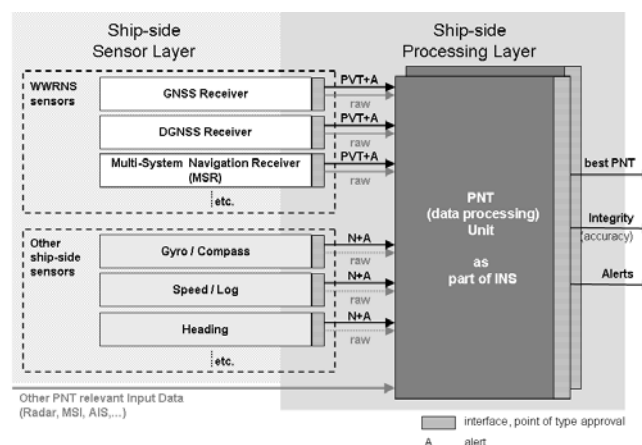

Figure 4. PNT Unit approach

### 2.2 Understanding of Integrity and Integrity Monitoring

Integrity can be categorized into "data integrity" and "system integrity". Data integrity is given, if the desired output data is provided at the expected time in the specified formats, and meanwhile, the specific accuracy requirements are fulfilled. System integrity is given, if (1) the integrity of all output data of a system is fulfilled and (2) the output data, additional status messages, and alert messages are provided in a

timely, complete, unambiguous and accurate manner. From these definitions it can be seen that the system integrity can only be given as long as the system realizes its tasks with the required performance. According to these definitions, integrity monitoring needs to include error estimations for all output data. These estimated errors need to be compared against given accuracy requirements. Whenever these requirements are not fulfilled, an alert message should be generated within a specified time.

Integrity monitoring within the PNT Unit can be carried out in three sequential steps, which have been discussed in detail in [4]. The first step is the test of individual sensors including provided sensor data. The second step is the compatibility test of similar data from different sensors. The third step is the fault detection and identification in the integration algorithm. Examples for specific realizations of these steps will be given in the next section.

### 3 INITIAL PNT UNIT REALIZATION

In order to demonstrate the functionalities of a PNT Unit, a prototype of such a PNT Unit is realized within our research project. Basis for the realization of this prototype is a real-time capable C++ development framework, which has been developed in our group and upgraded especially for the PNT Unit developments (for details see [8]). This framework has the advantage that identical core algorithms can be used either in a real time or in a post processing environment. Furthermore, it enables parallel processing using multiple threads of one computer.

As a prerequisite for the PNT Unit prototype development, a decision about the used sensors had to be made. The basis for the PNT Unit are the maritime standard onboard sensors like GNSS receivers, speed log and gyrocompass. Besides that, we have decided to use an Inertial Measurement Unit (IMU) as an additional sensor. On the one hand, an IMU can bridge short-term outages and disturbances of GNSS and enables therefore the establishment of a short-term contingency functionality for most of PNT parameters. On the other hand the diversity of IMU outputs furthermore enables integrity monitoring for relevant parameters. A limitation of IMU in maritime navigation lies in accuracy degradation for long-term operation, so that the integration of IMU with other navigation sensors is necessary to realize a long-term stable operation.

#### 3.1 Measurement campaigns

In order to collect test data for the development and validation of the PNT Unit, several measurement campaigns have been performed. The examples shown in this paper will concentrate on a measurement campaign performed in cooperation with the Federal Maritime and Hydrographic Agency (BSH) on the survey and research vessel DENEK. The vessel was equipped with 3 GNSS antennas and receivers (type: Javad Delta), an IMU (type iMar IVRU FCAI), a gyrocompass, a Doppler speed log, an electromagnetic speed log and other standard

shipborne sensors. Fig. 5 shows the vessel DENEK, where the red circles mark the positions of the 3 GNSS antennas and the yellow circle indicates the position of the IMU installed near the centerline inside the vessel.



Figure 5. Vessel DENEK with sensor locations

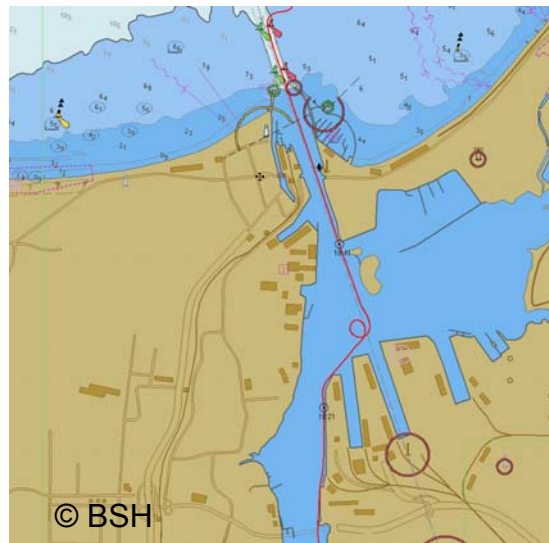

Figure 6. Trajectory of vessel DENEK

The trajectory of the vessel for the time slot of one hour is illustrated in Fig. 6. Leaving the Warnow River, the vessel performed an anti-clockwise turning maneuver and finally she left the port and led into the Baltic Sea. Based on the master station located near Rostock port, differential positioning with carrier phase measurements have been performed in post-processing to obtain the reference trajectory in centimeter accuracy.

#### 3.2 Consistent Common Reference System (CCRS)

Due to the size of vessels and the distribution of sensors, the position and velocity information measured by different sensors need to be converted to a consistent common reference point (CCRP). Heading information, as well as the other Euler angles and their change rates are needed for this conversion. Therefore, an accurate determination of ships attitude and their temporal changes are a prerequisite for PNT parameters determination. Besides that, the integrity of the other output parameters like position and velocity relies also on the integrity of the attitude information. A detailed discussion of our PNT Unit based approach of attitude determination can be found in [10]. Here only the basic ideas will be briefly introduced.

The maritime standard sensor for heading determination is the gyrocompass. If it is properly settled, it provides long-term stability. However, the accuracy depends on the actual ship motion and is limited to few degrees (see [9] [10]). The usage of a 3 antennas GNSS-Compass with a large baseline length (as we have installed it on the vessel DENEBO) yields an accuracy with a standard deviation:  $\sigma \leq 0.01^\circ$  for all Euler angles.

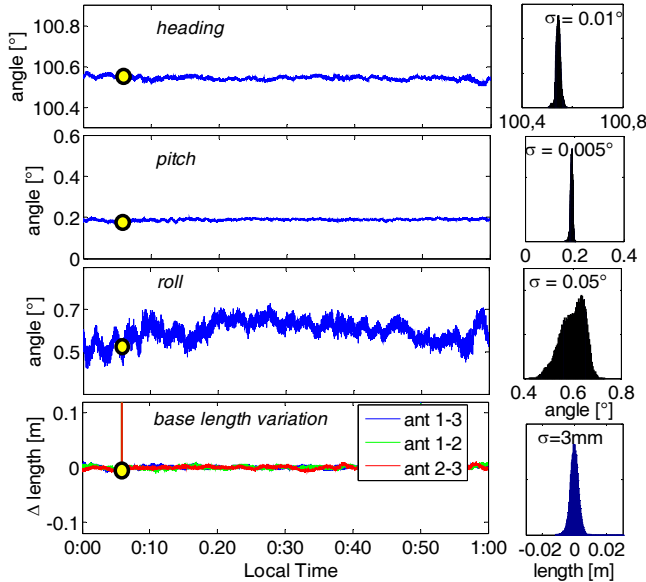

Figure 7. Heading, pitch and roll determination using GNSS-compass in quasi-static scenario at port

In Fig. 7 heading, pitch and roll angle determined with a GNSS-compass are shown for quasi-static scenario, where the vessel is moored. Additionally, the challenges of a GNSS-compass are shown.

The yellow circle indicates the epochs at which GNSS-compass does not provide reliable results. The quality of the GNSS-compass can be evaluated by the baseline length (see lower graph in Fig. 7), which should stay constant as long as the GNSS carrier phase measurements are correctly processed. Unreliable attitude results can be detected by larger variations in the baseline length. These outliers might occur with a failed solution of integer ambiguities, which is the most crucial step within the GNSS-compass data processing. In this sense, a GNSS-compass offers high accuracy but limited availability and continuity. In order to overcome these limitations, a GNSS-compass should be used in combination with other sensors, like an IMU. In a sensor fusion scheme, an IMU can be used for the detection of GNSS compass outliers as well as for the provision of a backup during the times of GNSS compass outages. Therefore, within our prototype PNT Unit, an attitude determination based on the fusion of a GNSS-compass and an IMU serves as an accurate and reliable basis of a CCRS.

### 3.3 Integrity monitoring with compatibility tests

As mentioned before, the second step of integrity monitoring refers to the compatibility test for PNT data obtained from different sensors. As an example, the compatibility tests for SOG determination are presented in the following.

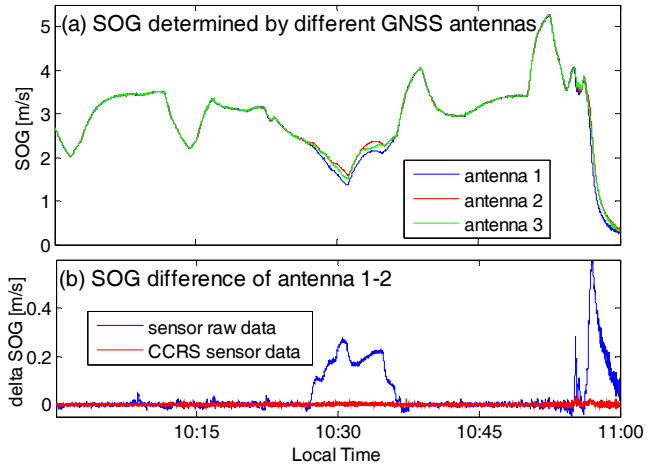

Figure 8. (a) SOG determined by the different GNSS antennas, (b) SOG difference of antenna 2 and antenna 1 with/without being converted onto a CCRS

In Fig. 8 (a) SOG data, determined by the three different GNSS antennas (see Fig. 5) are shown. One can clearly see systematic differences especially during the turning maneuver around 10:30 local time and at the end of the scenario. As it is illustrated in Fig. 8 (b), these systematic differences indeed vanish if the sensor raw data are converted into a CCRS. For the SOG compatibility tests within the integrity monitoring one either accepts larger systematic differences between distributed sensors or needs to convert the sensor data into a CCRS before performing the compatibility test. The second option has the disadvantage that the integrity tests for one output parameter (e.g. SOG) depend on the availability and integrity of the CCRS itself.

### 3.4 Integrity monitoring within the sensor fusion

The PNT Unit concept (see Fig. 4) enables the usage of sensor raw data within the sensor fusion algorithm. In order to demonstrate the advantage of this approach we have implemented a tightly coupled GNSS/IMU sensor fusion algorithm based on an extended Kalman Filter. A detailed description of the implementation can be found in [11]. Here only the basic ideas and results are presented.

In comparison to a loosely coupled GNSS/IMU Kalman filter, where the position results of a GNSS receiver is used as an input, in a tightly coupled Kalman filter the raw pseudorange measurements from each satellite in view are processed in the filter. This allows a failure detection of each individual GNSS observable. As an essential step of the Kalman filter routine, the calculation of the innovation vector reflects the deviation of the predicted pseudoranges with respect to the real measurements. As long as the dynamic model is working properly, the innovation vector mainly reflects the potential failures hidden on each measurement. Based on this fact, the failures manifest themselves as abnormal jumps in the innovation sequence of a specific measurement. This is the basis for integrity monitoring based on innovation checks in a Kalman filter.

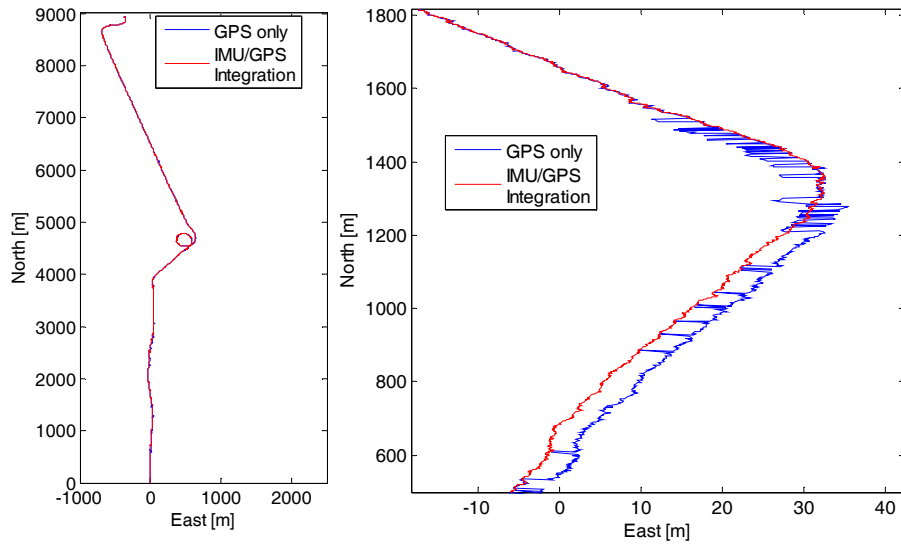

Figure 9. Tightly-coupled GPS/IMU integration with and without satellite filtering

In the data processing, we use a fixed threshold for innovation magnitude of pseudoranges in order to detect and remove faulty measurements. The trajectories processed using single-point positioning and GPS/IMU integration with that satellite filter are depicted in Fig. 9, where the graph at the left-hand side shows the whole trajectory within one hour and the graph at the right-hand side is a zoom-in for the first 20 minutes for a clearer illustration.

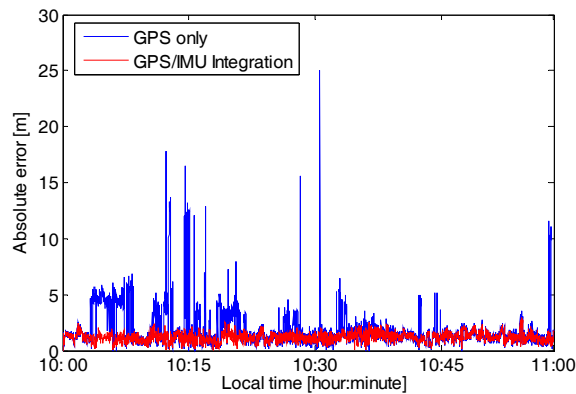

Figure 10. Horizontal accuracy of (1) tightly-coupled GPS/IMU integration with satellite filtering and (2) stand-alone GPS

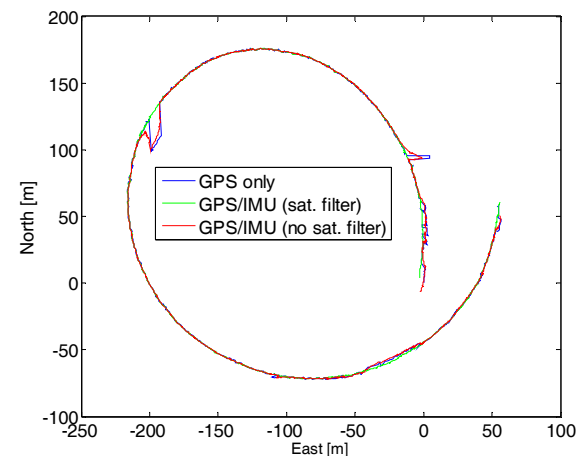

Figure 11. Tightly-coupled GPS/IMU integration with and without satellite filtering

The GPS/IMU integration gives a much smoother trajectory compared to the GPS-only solutions. In order to show the improvements in terms of accuracy, the absolute positioning errors in the horizontal plane are calculated by comparing with the reference trajectory and presented in Fig. 10.

The integrated system shows stable errors limited to 3 meters for most of the observation epochs. Contrarily, the GPS-only results show significant outliers. A more detailed analysis [11] shows that these errors are caused by signal distortions from low elevation satellites. The innovation filter automatically detects and removes these faulty measurements.

The conventional GPS/IMU integration works also without satellite exclusion. The dynamics measured by IMU could somehow adjust the positioning errors caused by low measurement quality. In Fig. 11 the corresponding trajectory is also illustrated, together with its counterparts using single-point positioning and using the integration with satellite filtering.

### 3.5 Contingency functionality

One of the base functionalities of the PNT Unit is the capability to provide PNT data even in case that a main PNT sensor is malfunctioning. For the provision of position information we currently have one main sensor: GNSS receiver 1, with two redundant sensors: GNSS receiver 2+3 and one contingency sensor: IMU. A contingency system, as defined by IALA [12], allows safe completion of a maneuver, but may not be adequate for long-term use. In order to demonstrate the contingency functionality of the IMU in strap-down processing in the case that all GNSS sensors provide no valid position information, three GNSS outage periods with one-minute duration are manually set to the GNSS raw measurements. Before and after the GNSS outage epochs, the IMU is tightly integrated with GNSS pseudorange and Doppler measurements, whereas during the GNSS-outage epochs, the IMU totally relies on its strap-down processing.

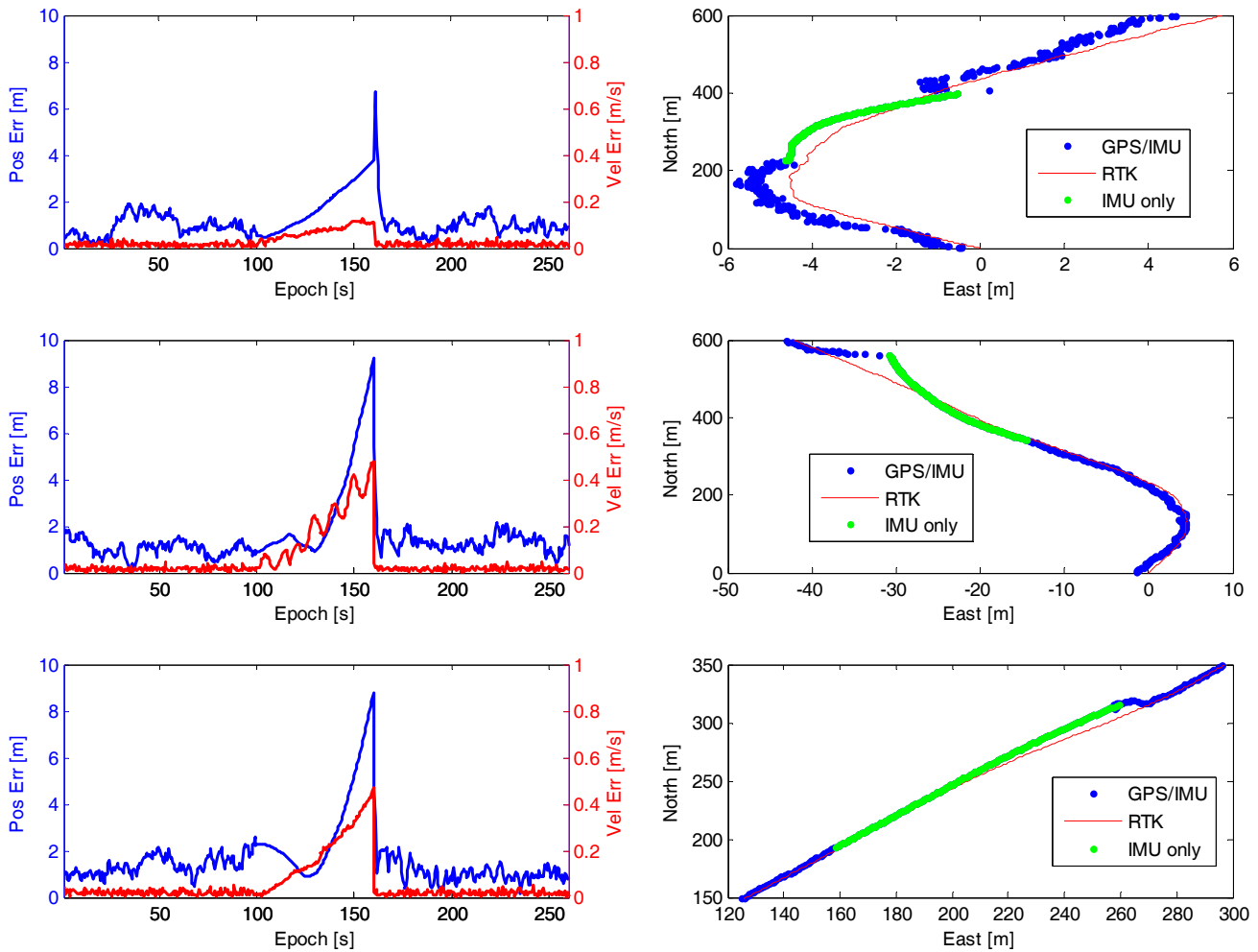

Figure 12. IMU contingency functionality, left: position error (blue) and velocity error (red), right: trajectories for three different GNSS outages of one minute

In Fig. 12, two sub-figures in the same row correspond to a GNSS outage period, where the sub-figure on the left-hand side shows the horizontal velocity and position errors of IMU and the sub-figure at the right-hand side illustrate the trajectory in horizontal plane. Within one minute, the position error drifts to around 10 meter and the velocity error to around 0.5 m/s. The concrete performance of the strap-down processing depends highly on the accuracy of initial values of PVT parameters at the beginning of strap-down processing.

From Fig. 12 it can also be seen that, once the GNSS signals become available, the drift effects can be gradually adjusted by GNSS.

In comparison with position parameters, the velocity error is affected by IMU measurement errors to a much larger extent. The position drifts are caused by the accumulation of the velocity error. If we have other sensors to indicate the velocity, the drift of IMU velocity error, and moreover the position drifts, will be significantly reduced. Driven by this idea, the use of speed log could serve as a proper backup system to be integrated with an IMU.

Depending on the accuracy requirement in different operation areas, the IMU can perform the contingency functionality with different time durations. For example, in the coastal area, the position error must be smaller than 10 meter, and

hence the IMU contingency functionality cannot work for more than one minute. In the deep sea area, the position error is tolerated up to 100 meters, so that the IMU can operate independently for longer time, however, no more than several minutes, even with tactical grade IMU and good initialization.

### 3.6 Position error estimation

As discussed in section 2.2 the PNT Unit needs to provide integrity information to the onboard user, which is based on accuracy estimation. In a first step the GNSS stand-alone approach based on a classical Fault Detection Receiver Autonomous Integrity Monitoring (RAIM) algorithm [13] can be used for this purpose. This technique was firstly introduced in the aviation sector for using only reliable satellites during safety-critical landing approaches. It determines the integrity of GNSS signals based on consistency checks among redundant pseudoranges. The RAIM aims at the determination of whether the system or individual measurements meet the navigation performance requirements [14]. One output of RAIM is the Horizontal Protection Level (HPL). HPL is a statistical bound of the horizontal position error computed to guarantee that the probability of the horizontal position error exceeding that number is smaller than or equal to the target

integrity risk [15]. Integrity risk is the probability that, at any moment, the position error exceeds a predefined maximum positioning error limit without identification by the integrity monitoring. We computed the HPL based on the requirements of integrity risk for future maritime radio navigation systems as specified by the IMO [16] for ocean and coastal navigation mode. The Integrity Risk for ocean/coast navigation here is specified to  $1e-5$  over a time period of 3 hours.

Fig. 13 shows the horizontal positioning error, the associated error upper bound under 95% confidence level and the HPL for a time period of around 40 minutes where the vessel is moored at the port of Rostock.

The 2D real position accuracy is obtained by comparing the single-point positioning results with a post processed RTK solution. Additionally the number of visible satellites with the predefined elevation cut-off angle of 5 degrees is shown. For the calculation of HPL we assume, that the pseudorange error variance for each satellite depends on the elevation angle in the following form [17]:

$$q_i = \left( \frac{\sigma_i}{\sin \alpha_i} \right)^2 \quad (1)$$

where  $\sigma_i$  is the predefined standard deviation of the pseudorange error and  $\alpha_i$  the elevation angle of the  $i^{\text{th}}$  satellite. The  $\sigma_i$  for all pseudoranges was set to 3.2 meter.

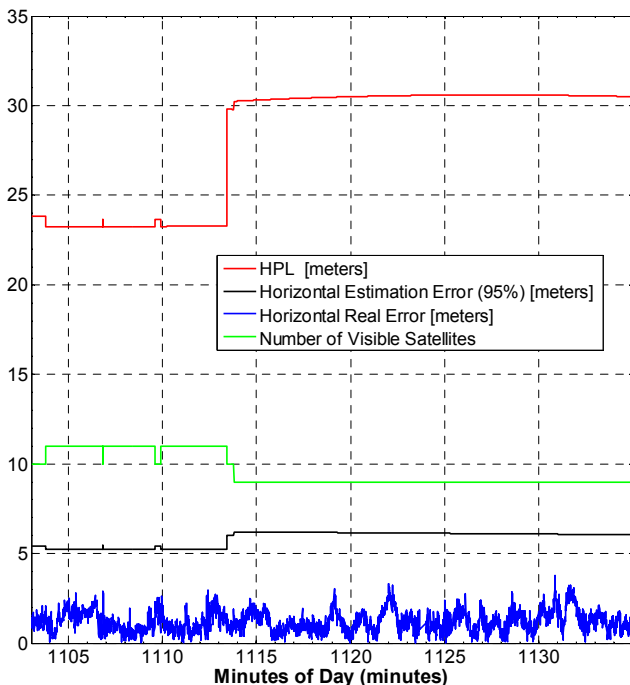

Figure 13. Horizontal protection level, horizontal position estimation and real error and the number of visible satellites.

According to Fig. 13, the position 95% error estimation is around 5 meters which clearly bounds the real positioning errors for that (short) period of time. In order to really draw conclusions, a statistical analysis of much longer time periods is required. The

computed HPL can be interpreted as an overbound of the horizontal error with a probability of 99.99%. It can also be seen that the HPL will change with the satellite constellation.

This first analysis should be understood as a starting point for the discussion within the maritime community how the integrity should be assessed for maritime users.

#### 4 SUMMARY

In this paper, the maritime integrated PNT Module as the on-board part of a maritime PNT system is introduced. The core of the PNT Module is a PNT data processing Unit enabling the integrated utilization of all available sensor data to establish the needed redundancy for improved PNT data provision and integrity monitoring. Important aspects and benefits of such a PNT Unit are shown together with examples regarding different integrity monitoring methods.

The CCRS, as a prerequisite for the fusion of data from different sensors at different locations, is introduced. Compatibility tests for SOG sensors show the importance of conversion of sensor data into a CCRS. A tightly-coupled GPS/IMU integration enables the innovation checks for the detection and removal of outliers in GNSS pseudorange measurements. The usage of an IMU is not only beneficial for the integrity monitoring but also provides contingency functionality. In our case, where we have used a tactical grade IMU, the position error increased to around 10 meters and the velocity error to around 0.5 m/s within one-minute GNSS outage. Another important aspect of the PNT Unit lies in the error estimation of PNT parameters. In a first approach we have adapted a horizontal position error estimation method for GNSS stand-alone positioning from the aviation sector to the maritime requirements. A more detailed discussion of the required error estimation, as a basis for integrity provision for maritime users, will be a subject of future work.

#### ACKNOWLEDGMENTS

The authors would like to thank the Federal Maritime and Hydrographic Agency of Germany (BSH), in particular Mr. Tobias Ehlers and the crew of the DENEb with their captain Mr. Gentes for the support during the measurement activities. The authors are also grateful for the assistance of their colleagues Pawel Banyś, Carsten Becker, Alexander Born, Stefan Gewies, Frank Heymann, Uwe Netzband, Philipp Zächhuber.

#### REFERENCES

- [1] IMO, "NAV 54/25 Annex 12 Draft strategy for the development and implementation of e-Navigation," 2008.

- [2] IMO, "NAV 55/WP.5 Development of an e-Navigation Strategy Implementation Plan," NAV55/WP5, Jul. 2009.
- [3] Germany IMO, "NAV 58/6/1 IMO input paper: Proposed architecture for the provision of resilient PNT data Submitted by Germany." 30-Mar-2012.
- [4] R. Ziebold, Z. Dai, T. Noack, and E. Engler, "Concept for an onboard integrated PNT Unit," TransNav, the International Journal on Marine Navigation and Safety of Sea Transportation (<http://www.transnav.eu>), vol. 5, no. 2, pp. 149–156, 2011.
- [5] IMO, "SOLAS CHAPTER V: SAFETY OF NAVIGATION," Jul. 2002.
- [6] IMO, "Resolution MSC.252(83): Adoption of the Revised Performance Standards for Integrated Navigation Systems (INS)," Oktober 2007.
- [7] IEC, "Maritime navigation and radiocommunication equipment and systems – Integrated navigation systems, Operational and performance requirements, methods of testing and required test results," 2006.
- [8] S. Gewies, C. Becker, and T. Noack, "Deterministic Frame-work for Parallel Real-Time Processing in GNSS Applications," Proceedings of the 6th ESA Workshop on Satellite Navigation Technologies. Navitec 2012, 5.-7. Dec. 2012, Noordwijk, The Netherlands., 2012.
- [9] Z. Dai, R. Ziebold, A. Born, and E. Engler, "Heading-determination using the sensor-fusion based maritime PNT Unit," ION PLANS, 2012.
- [10] IMO, "Resolution A.424(XI): Performance Standards for Gyro Compasses," Nov. 1979.
- [11] Z. Dai, R. Ziebold, and E. Engler, "The on-board maritime PNT Module – a focus on integrity monitoring and preliminary results," European Navigation Conference GNSS (ENC GNSS 2011), 28.Nov-2.Dez.2011, London, United Kindom.
- [12] IALA, "Recommendation R-129: On GNSS Vulnerability and Mitigation Measures Edition 2," 2008.
- [13] T. Walter and P. Enge, "Weighted RAIM for Precision Approach," 1995.
- [14] B. Hoffman-Wellenhof, H. Lichtenegger, and E. Wasle, GNSS-Global Navigation System, GPS, GLONASS, Galileo and More. 2008.
- [15] "Integrity," <http://www.navipedia.net/index.php/Integrity>
- [16] IMO, "Resolution A.915(22): Revised Maritime Policy and Requirements for A Future Global Navigation Satellite System (GNSS)," Nov. 2001.
- [17] Jean-Philippe Montillet, Kegen Yu, "On a New Weighting Matrix to Enhance the Accuracy of Stand-Alone GNSS Positioning," International Symposium on Communications and Information Technologies (ISCIT), 2012.