

THE INFLUENCE OF FINITE ELEMENT MESHING ACCURACY ON A WELDING MACHINE FOR OFFSHORE PLATFORM'S MODAL ANALYSIS

Jiuming Xie¹
Dengyue Sun²
Chengying Xu¹
Jin Wu¹

¹ School of Mechanical Engineering, Tianjin Sino-German University of Applied Sciences, Tianjin, China

² National Engineering Research Center for Equipment and Technology of Cold Strip Rolling, Yanshan University, Qinhuangdao, China

ABSTRACT

The purpose objective of this study was to investigate the influence of finite element meshing accuracy on modal analysis which is one of the basic factors affecting the accuracy of finite element analysis and mostly preoccupies the working staff in pre-processing finite element simulation models. In this paper, we established several finite element models of a welding machine for offshore platform, with the meshing accuracy as the variable and workbench software as the platform for modal analysis, as the same time, comparing the analysis results. The results indicated that for some specific structures and simulation types, mesh refinement alone does not achieve desired results, and the authors indicate that mesh refinement is rarely related to the equipment's low-frequency modal analysis but it's great related to the equipment's high-frequency modal analysis. The findings of this study may serve as breaking the opinion that smaller mesh size means higher calculation precision and provides references for mesh division practices in low frequency modal analysis.

Keywords: Finite element analysis, Meshing, Meshing accuracy, Modal analysis

INTRODUCTION

With the rapid development of the finite element software and simulation technology, finite element analysis has been widely used in engineering, gaining momentum in analyzing the static and dynamic characteristics of structures, equipment, etc. [1]. Modal analysis is the fundamental dynamic finite element analysis, and a numerical technique to calculate the vibration characteristics (i.e. natural frequencies and formation) of structures and equipment [2].

As a theoretical mathematical modeling process, modal analysis is the field of discretizing vibration structures and seeking the solutions to system eigenvalues and eigenvectors with approximation approaches and finite element analysis [3]. In finite element software, the result of model analysis is used to determine the natural frequencies and modes of a structure,

and modal analysis is the basis of other kinetic analyses such as response dynamics analysis, harmonic response analysis and transient analysis [4].

In the finite element analysis of the equipment, the finite element mesh exerts measurable influence on calculation accuracy. Theoretically, smaller mesh size means higher calculation precision, but with the increase in finite element meshes, the computational efficiency is reduced, and in some cases, mesh refinement alone does not achieve desired results. In this paper, we studied on the influence of finite element mesh division precision on the modal analysis result of the welding machine for offshore platform which is designed according to the Tianjin Marine Economic Science and Technology Development Program—Research on double-sided steel structure welding technology and the welding equipment of structure reinforcement in Marine Engineering (KJXH2013-14).

THE BASIC PRINCIPLES OF MODAL ANALYSIS

Modal analysis is an approach to study the dynamic characteristics of a structure, and modality is the inherent vibration characteristics of mechanical structures. The latter one determines the structure's response to dynamic loads, each of which has a specific natural frequency, damping ratio and mode shape. Therefore, modal analysis must be carried out before other dynamic analyses.

In engineering practice, vibration systems are continuous elastic bodies, which theoretically belong to a system of infinite degree of freedom and need to be described by a continuous model. But the vibration system is always simplified as a model of finite degrees of freedom. In doing so, the system is abstracted as a model of lumped blocks and elastic elements [5–7]. Thus, the dynamic properties of a structure can be described by N-order matrix differential equations, i.e., the general dynamic equation is as follow:

$$[M]\{\ddot{u}\} + [C]\{\dot{u}\} + [K]\{u\} = \{F(t)\} \quad (1)$$

In the formula, $[M]$, $[C]$ and $[K]$ are the respective mass matrix, damping matrix and individual matrix, $\{\ddot{u}\}$, $\{\dot{u}\}$, $\{u\}$ are the structure's respective acceleration vector, velocity vector and displacement vector, and $\{F(t)\}$ is the excitation vector of the structure.

In conducting modal analysis, we assume $F(t) = 0$ and ignore $[C]$. The natural frequency of the structure is determined by the properties of the structure itself, independent of the external load; the damping has little effect on the natural frequency and mode of the structure [8].

The general dynamic equation under free vibration (free of external load and neglecting damping effect) is as follow:

$$[M]\{\ddot{u}\} + [K]\{u\} = 0 \quad (2)$$

When resonance occurs, $u = U\sin(\omega t)$, and the equation becomes:

$$([K] - \omega_i^2 [M]) = \{\varphi_i\} = 0 \quad (3)$$

For the modal analysis of a structure, its natural circular frequency ω_i and formation φ_i are derivable from the matrix equation above, and the equation root or eigenvalue is ω_i^2 , i ranging from 1 to the numerical number of degrees of freedom. The corresponding vector is the eigenvector $\{u\}_i$. The square root of the eigenvalue is ω_i , which expresses the natural circular frequency structure (rad/s) and thus we calculate the natural frequency $f_i = \omega_i/2\pi$. $\{u\}_i$ represents vector formation or structure mode in the engineering sense, which is the structure shape when vibrating at the frequency of f_i . Thus, the natural frequencies of the system and their corresponding modes of vibration can be solved. Modal extraction is only used to describe eigenvalues and eigenvectors.

ESTABLISHMENT OF THE SOLID MODEL

In establishing a finite element analysis model, we combine parametric modeling and feature-based solid modeling to effectively realize the output requirements of the full-scale simulation model [9]. The UG-based parametric modeling method allows the size and parameters of various part in the welding machine for offshore platform be modified at any time according to the design results; With feature modeling, the equipment model can be finished by operations of superimposing, intersecting, cutting, etc. In the process of modeling, in order to reduce the number of model features and mesh elements and shorten the computation time, some insignificant features such as small round corners and small holes are excluded. After the solid model is established, the UG modeling module interface can be directly switched to the UG / CAE pre-processing module to further complete the work of finite element meshing, which avoids the model distortion in the data transfer process between software [10].

The main structure and characteristics of the welding machine are constructed as follows to meet the design requirements (Du et al., 2014). Based on the working conditions and technical requirements of welding machine for offshore platform, the main structure and characteristics are designed, and the final design model structure is shown in Figure 1.

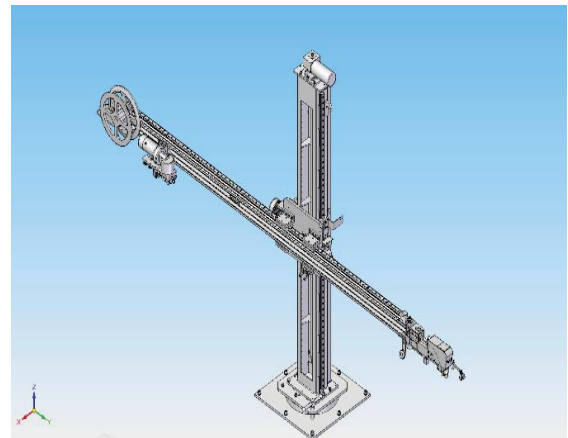

Fig. 1. The modal of welding machine for offshore platform

As can be seen from Figure 1, the welding machine for offshore platform has a very complex structure with a variety of chains, bearing holes, connecting holes, etc. In the finite element analysis, the model must be simplified appropriately lest the model complexity will cause extra troubles to our follow-up work.

In order to reflect the structural and mechanical characteristics, the simplification must follow the following principles:

- 1) Represent the structural geometry and force transmission route of the model in an accurate manner.
- 2) Apply the quality equivalent method by removing small bearing bores/bodies and chamfering secondary parts.

- 3) Simplify thin-walled structure (irregular and complex components like bearings or sensors do not affect the analytical accuracy).
- 4) Conduct the finite element equivalent treatment on loads under various working conditions. The simplified model is shown in Figure 2.

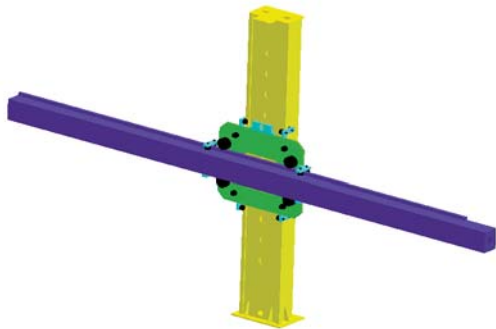

Fig. 2. The simplified model of welding machine for offshore platform

FINITE MODEL MESH DIVISION

In the finite element simulation analysis, the meshing of the finite element is particularly important as the main pre-processing part. The quality of division is directly related to the simulation scale, speed, the subsequent finite element calculation, the accuracy of analysis results and the success of computing. Meanwhile, mesh division involves element shape and type, topology type, the choice of mesh generator, grid density, geometric speed, etc. [11, 12].

In dividing finite element meshes, the element type must be determined first, and the results obtained by different element types are different. If all the structural elements are ideally composed of equilateral triangle, square, tetrahedron or cube hexahedron, the simulation accuracy should be close to the actual value. However, as this situation is rarely seen in practical engineering structures, it is necessary to select those mesh types and shapes that can fit for model characteristics, to improve mesh quality and the precision of solutions [13]. Mesh quality is generally considered from the aspects of distortion and aspect ratio. The ideal side ratio of meshes is 1:1. On the premise of uniform mesh size, the calculation result will be less accurate if the side ratio becomes larger. However, when the meshes are intensified in parallel in a certain direction, the mesh size will decrease, which contributes to precise calculation, while the aspect ratio will increase, which reduces calculation precision [14].

Based on the above analysis, in the finite element mesh, in order to truly reflect the structure and the actual situation of welding machine for offshore platform, the high-order 3D 20-node Solid186 is chosen to simulate the structure of different parts. The solid structure unit has a quadratic displacement mode to simulate irregular grids. It also supports the simulation

of the parts with high plasticity, super elasticity, creep, stress, toughness, deformation, strain and spatial anisotropy. Once some nodes overlap, hexahedron units will degrade into tetrahedrons, wedges, pyramids or prisms [15], as shown in Figure 3.

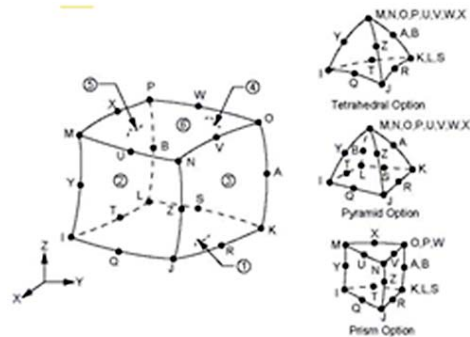

Fig. 3. The mesh of Solid186

The density of mesh directly affects the accuracy of calculation results and the size of the calculation scale. Generally, if the mesh number increases, the calculation precision can be improved, which is equal to the enhanced finite element convergence. However, the computation scale will increase greatly at the same time. And the calculation accuracy is increase very rarely once the mesh number increase to a certain extent, while the calculation scale is much larger. Therefore, the grid number should be decided taking the account of both computation scale and calculation precision. Generally, in calculating the structural dynamic characteristics, fewer grids can be used in calculating low-order modes; but more grids are required for high-order modes. Grids should be divided finer in the structure where mutation happens.

Finite element meshing is done by using adaptive partition strategy, so that the meshes can be refined or coarsened continuously in the iteration process in areas with abrupt changes. In this way, mesh points distribution is coupled with physical solution to improve the precision and resolution ratio of solutions. When the relevance in meshing are 80 and 40 respectively, mesh quality is inspected in terms of aspect ratio, area ratio or volume ratio, twist degree and density transition.

The mesh is divided by different relevance, and the number of elements and nodes are obtained, as shown in table 1:

Tab. 1. The compare of the mesh in different relevance

relevance	number of elements	number of node
40	50286	180058
80	71464	250567

The mesh results at the relevance of 80 is shown in Figure 3:

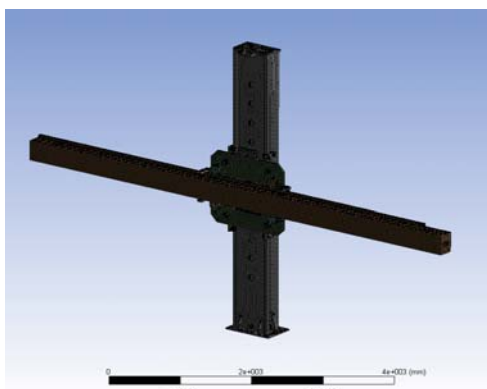

Fig. 3. The result of the mesh

The mesh quality inspection result at the relevance of 80 is shown as Figure 4:

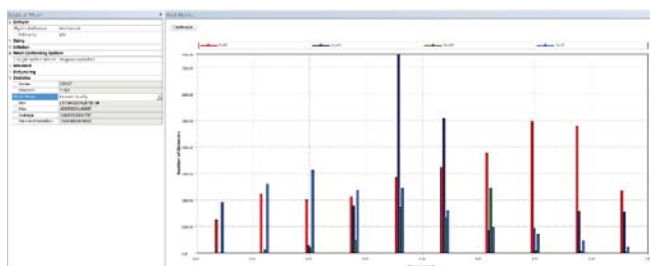

Fig. 4. The result of the mesh quality checking

MODAL ANALYSIS

The welding machine for offshore platform must meet the requirement of NVH (Noise, Vibration, Harshness), and the natural frequency is the main factor to evaluate the NVH characteristics of the structure and to determine the accuracy of the vibration response. Natural frequency is an important means to avoid the resonance between mechanical parts and the structure [16]. Therefore, it is a must to conduct modal analysis on the welding machine for offshore platform, lest there are unnecessary noises or resonance in the structure. At the same time, modal analysis is the basis of seismic response spectrum analysis. The modal analysis method can determine the natural frequency and vibration mode at any order, through which the structure's modal characteristics can be determined in a frequency range vulnerable to changes to achieve the goal of predicting the possible actual vibration responses in this frequency range under the action of various seismic focuses [17]. In order to carry out the seismic response spectrum analysis, the structure's natural frequencies and vibration modes must be calculated out through modal analysis.

Generally, all modes do not play a role in the seismic response of welding machine for offshore platform. In order to ensure the precision and accuracy of seismic calculation results, additional modes of modal mass participation coefficients should be used [18]. In this calculation, if the modal mass reached the request of 90% of the total mass, the participation coefficient of vibration modes must be evaluated to identify which vibration

modes play a major role in the subsequent earthquake load. In this way, we can select adequate vibration modes.

Modal analysis mainly uses the methods of subspace iteration and Block Lanczos. The method of subspace iteration is mainly suitable for solving the problem of extracting a few order modes in the large-scale eigenvalue problem, and the complete mass and stiffness matrix used in the method has high precision. However, demands for mesh quality are high and the calculation time is long [19]. The method of Block Lanczos uses a sparse matrix solver with similar precisions, responds well to ill-conditioned matrixes, and is quite time-saving. However, demands for memory are high and the method is limited to the case of extracting multi-order modes with large degrees of freedom [20]. In this paper, to improve the speed of calculation, Block Lanczos is used in modal analysis.

Before the modal analysis, it is necessary to set the boundary conditions of the welding machine for offshore platform [21]. The boundary conditions of welding machine in the actual operation process are very complex, which not only renders loading difficult to achieve, but increases the calculation load of finite element analysis [22]. To facilitate loading and simplify the calculation, the boundary conditions and loading should be equivalent. The welding machine for offshore platform model is an assembly in which all parts are connected with sliding pairs and revolute pairs [23]. Surface constraints are applied between the two parts, and the corresponding units are formatted automatically on the constrained surfaces. Then, the corresponding units are connected to form a complete and continuous [24]. The entire welding machine for offshore platform is connected with the base through the bottom connecting hole. Fixed support is applied to the surface of the bottom connecting rod. The welding machine for offshore platform is mainly subjected to the following long-term, stable loads:

- 1) The gravity of the welding machine itself, which is simulated by applying the standard gravity along the Z-direction, $g=9806.6\text{mm/s}^2$;
- 2) The gravity of the welding flux and the motor on the left, which is properly magnified into the gravity loads.
- 3) The gravity of the submerged arc welding machine on the right, which is properly magnified into the gravity loads.

According to the actual working conditions of the welding machine for offshore platform, the boundary conditions and load models of the equivalent welding machine are shown in Figure 5.

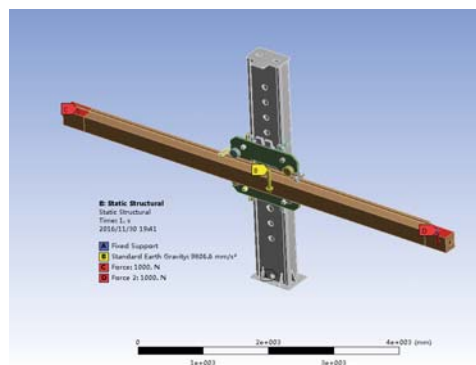

Fig. 5. The load model of the welding machine

In order to compare the influence of different grid numbers on the modal analysis, the frequency and formation of modal analysis at respective low and high orders (first-order, second-order, fourth-order and fiftieth-order) are extracted in the process of morphological analysis. The modal frequencies at each order under different relevance are shown in the Table 2.

Tab. 2. The modal frequency at each order under different relevance

order	modal frequency in different relevance		Error
	relevance 80	relevance 40	
1	6.669	6.537	2.0%
2	11.633	11.208	3.7%
4	24.770	23.986	3.2%
50	356.17	308.49	13.4%

In fact, for the pre-stressed non-free modal analysis which only responds greatly to low-order frequencies, we can simplify the analysis by analyzing the first ten frequencies and the corresponding vibration modes.

It can be seen from Table 2 that the natural frequency of the model increases with the increase of the order. The rated speed of the welding machine motor is 1500r / min and the excitation frequency is 25Hz. It can be seen from the modal analysis that the frequency of the model and the fundamental frequency of the welding operator differ little at the fourth order, meaning the easiness to resonate [25]. But after analysis, the equivalent participation quality of the welding machine is 18.6 %, so there are no security risks in welding machine for offshore platform.

The various modes of vibration distribution in different conditions of grid division are shown in Figure 6:

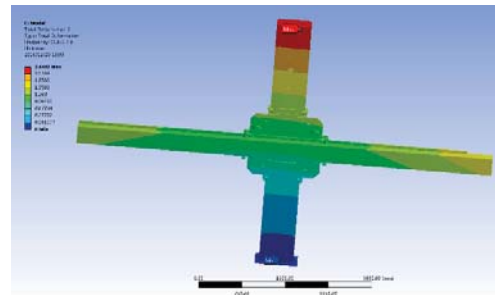

(c) The second-order vibration mode at the relevance of 80

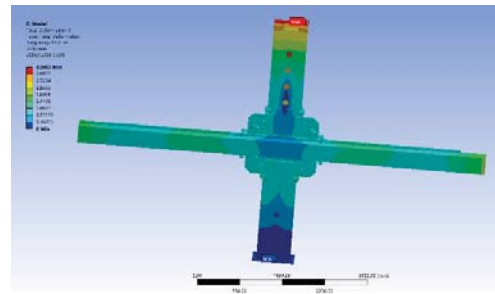

(d) The second-order vibration mode at the relevance of 40

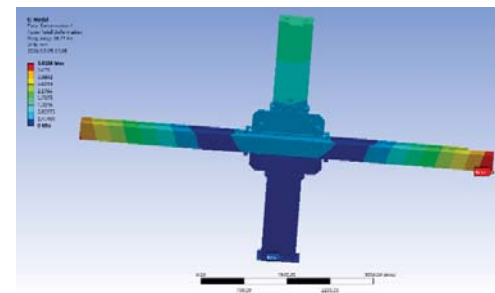

(e) The fourth-order vibration mode at the relevance of 80

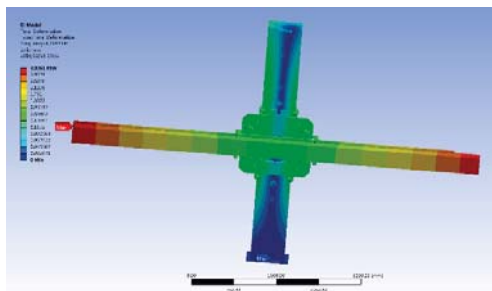

(a) The first-order vibration mode at the relevance of 80

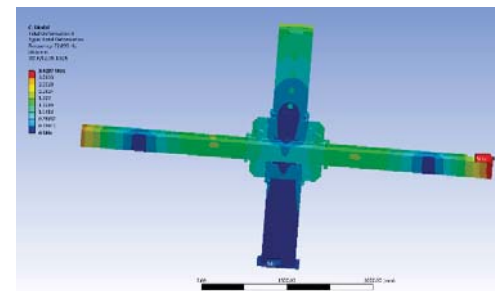

(f) The fourth-order vibration mode at the relevance of 40

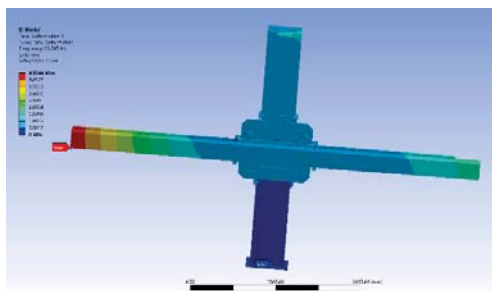

(b) The first-order vibration mode at the relevance of 40

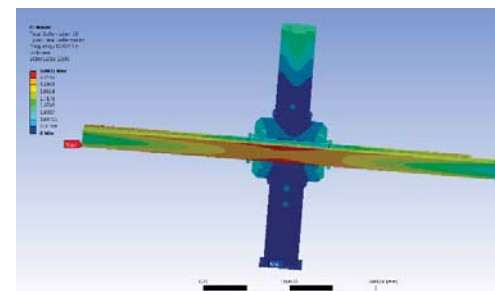

(g) The fiftieth-order vibration mode at the relevance of 80

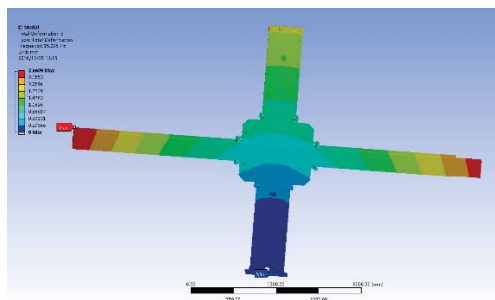

(h) The fiftieth-order vibration mode at the relevance of 40

Fig. 6. The various modes of vibration distribution in different conditions of mesh division

It can be seen from the modal analysis results that the difference between frequencies and between amplitudes under different meshing precisions are less than 10% at the first/second/fourth order but more than 10% at the fiftieth order. Therefore, for the low-order modal analysis, the partitioning accuracy of the mesh has little effect on the modal analysis results [26]. For the high-order modal analysis, the meshing accuracy of the mesh has a great influence on the modal analysis results. In the low-order modal analysis, the accuracy of meshing can be slightly lower to increase the speed of the calculation; while in the high-order modal analysis, we should try to improve the accuracy of meshing to obtain more accurate results.

CONCLUSIONS

In this paper, mesh division is carried out under different precisions in a welding machine for offshore platform, on whose basis the modal analysis is conducted. The main conclusions are as follows:

In the case that the solution accuracy meets the requirements, the difference between modal frequencies obtained by finite element modal analysis in different precision levels is small, and the modal formation is basically the same.

When the finite element method is used in low frequency modal analysis, the number of meshes can be appropriately reduced to improve the computational efficiency in the conditions to meet the accuracy requirements.

When the finite element method is used in high frequency modal analysis, it is necessary to increase the number of meshes to improve the precision of solutions without failing the accuracy requirements.

ACKNOWLEDGMENT

The research of this paper is made possible by the generous support from the project team of KJXH2013-14 and E2016203182.

REFERENCES

1. N. Larbi, and J. Lardies, *Experimental modal analysis of a structure excited by a random force*, Mechanical Systems & Signal Processing, Vol. 14, No. 2, pp. 181–192, 2000.
2. K. Yang, and T. Han, *The application of Ansys in modal analysis*, Journal of Jiamusi University (Natural Science Edition), Vol. 23, No. 1, pp. 81–84, 2005.
3. Y. N. Lv, Z. H. Lv, B. Zhao, and C. Wang, *A finite element analysis and topology optimization method for structures with free damping*, Chinese Journal of Computational Mechanics, Vol. 29, No. 2, pp. 178–183, 2012.
4. L. G. Cai, S. M. Ma, Y. S. Zhao, Z. F. Liu, and W.T. Yang, *Finite element modeling and modal analysis of heavy-duty mechanical spindle under multiple constraints*, Journal of Mechanical engineering, Vol. 48, No. 3, pp. 165–167, 2012.
5. X. Cui, L. Gao, and J. X. Liu, *Wind tunnel test study on the influence of railing ventilation rate on the vortex vibration characteristics of the main beam*, International Journal of Heat and Technology, Vol. 36, No. 1, pp. 65–71, 2018.
6. J. Huang, Z. Ji, H. M. Duan, and S. R. Qin, *Experimental modal analysis of mechanical structure and typical applications*, China Measurement & Test, Vol. 36, No. 2, pp. 4–8, 2010.
7. Y. Dai, S. M. Cui, and L.W. Song, *Finite element method modal analysis of driving motor for electric vehicle*, Proceedings of the Chinese Society for Electrical Engineering, Vol. 31, No. 9, pp. 100–104, 2011.
8. Y. Y. Cao, and D. F. Zhao, *Finite element modal analysis theory and application*, Mechanical Engineering & Automation, Vol. 140, No. 1, pp. 73–74, 2007.
9. W. G. Zheng, Z. J. Liu, and N. Yang, *Analysis on modal and static of steering pump bracket*, Machinery Design & Manufacture, No. 6, pp. 182–184, 2014.
10. E. W. Zhang, Y. S. Sun, and X. H. Zhou, *Example analysis in date conversion between UG and Ansys*, Mechanical Manufacturing & Automation, Vol. 36, No. 2, pp. 90–91, 2007.
11. I. G. Jang, and B. M. Kawk, *Evolutionary topology optimization using design space adjustment base on fixed grid*, International Journal for Numerical Methods in Engineering, Vol. 66, No. 11, pp. 1817–1840, 2006.
12. A. O. Cifuentes, and A. Kalbag, *A performance study of tetrahedral and hexahedral elements in 3-D finite element structural analysis*, Finite Element in Analysis and Design, Vol. 12, No. 3, pp. 313–318, 1992.

13. B. Y. Shih, and H. Sakurai, *Automated hexahedral mesh generation by swept volume decomposition and recomposition*, International Meshing Roundtable, pp. 273–280, 1996.
14. H. C. Lu, I. Song, W. R. Quadros, and K. Shinmada, *Geometric reasoning in sketch-based volumetric decomposition framework for hexahedral meshing*, Engineering with Computers, Vol. 30, No. 2, pp. 237–252, 2013.
15. C. F. Ning, Z. D. Fang, F. Wang, and X. Wang, *Several Entity Element in the Comparison of Aviation Gear Box Calculation*, Journal of Mechanical Strength, Vol. 4, No. 37, pp. 742–747, 2015.
16. V. N. Nikishin, A. P. Pavlenko, K. N. Svetlichnyi, and V. S. Makov, *Analysis of torsional crankshaft oscillations in a diesel engine on the basis of cylinder-block vibration*, Russian Engineering Research, Vol. 33, No. 12, pp. 687–691, 2010.
17. P. Han, J. J. Wang, and Z. R. Wang, *Elasto-plastic response spectrum analysis in the seismic design of viaducts*, Journal of Harbin Engineering University, Vol. 34, No. 4, pp. 461–470, 2013.
18. M. L. Aenlle, P. F. Fernandez, R. Brincker, and A. F. Cantel, *Scaling-factor estimation using an optimized mass-change strategy*, Mechanical Systems & Signal Processing, Vol. 24, No. 5, pp. 1260–1273, 2010.
19. Y. Saad, *Analysis of subspace iteration for eigenvalue problems with evolving matrices*, Siam Journal on Matrix Analysis & Application, Vol. 37, No. 1, pp. 103–122, 2016.
20. A. H. Bentbib, M. E. Guide, and K. Kbilon. *The block Lanczos algorithm for linear ill-posed problem*, scalcolo, pp. 1–22, 2016.
21. S. Kasim, N. A. Omar, N. S. Mohammad Akbar, R. Hassan, and M. A. Jabar, *Comparison Semantic Similarity Approach Using Biomedical Domain Dataset*, Acta Electronica Malaysia, Vol. 1, No. 2, pp. 1–4, 2017.
22. S. C. Sen, S. Kasim, M. F. Md Fudzee, R. Abdullah, and R. Atan, *Random Walk from Different Perspective*, Acta Electronica Malaysia, Vol. 1, No. 2, pp. 26–27, 2017.
23. S. Sathishkumar, and M. Kannan, *Design and Fatigue Analysis of Multi Cylinder Engine and Its Structural Components*, Acta Mechanica Malaysia, Vol. 2, No. 2, pp. 10–14, 2018.
24. A. Abugalia, M. Shaglouf, *Analysis of Different Models of Moa Surge Arrester for The Transformer Protection*, Acta Mechanica Malaysia, Vol. 2, No. 2, pp. 19–21, 2018.
25. X. G. Yue, and M. A. Ashraf, *Opposite Degree Computation and Its Application*, Engineering Heritage Journal, Vol. 2, No. 1, pp. 05–13, 2018.
26. M. Elmnifi, M. Alshelmany, M. Alhammaly, and O. Imrayed, *Energy Recovery from Municipal Solid Waste Incineration on Benghazi – Case Study*, Engineering Heritage Journal, Vol. 2, No. 1, pp. 19–23, 2018.

CONTACT WITH THE AUTHORS

Dengyue Sun

e-mail: sdy@ysu.edu.cn

National Engineering Research Center
for Equipment and Technology of Cold Strip Rolling
Yanshan University
Qinhuangdao – 066004
CHINA