



Volume 94

2017

p-ISSN: 0209-3324

e-ISSN: 2450-1549

DOI: <https://doi.org/10.20858/sjsutst.2017.94.13>



Journal homepage: <http://sjsutst.polsl.pl>

Article citation information:

Markiewicz, T., Kaczmarczyk, Ł., Fabiś, P. Influence of intake system modification on the formula student engine power. *Scientific Journal of Silesian University of Technology. Series Transport*. 2017, **94**, 139-149. ISSN: 0209-3324.

DOI: <https://doi.org/10.20858/sjsutst.2017.94.13>.

Tomasz MARKIEWICZ¹, Łukasz KACZMARCZYK², Paweł FABIŚ³

INFLUENCE OF INTAKE SYSTEM MODIFICATION ON THE FORMULA STUDENT ENGINE POWER

Summary. This paper is a summary of the design and workmanship of the formula student engine intake vehicle, for simulation research projects were conducted on the intake system. In the process, the most favourable model system was selected, which was capable of producing a satisfactory range of the characteristics of the engine. For chosen models, the intake system was also determined in terms of its impact on the power and torque of the test vehicle, which was driven by a four-cylinder engine with a displacement of 0.6 dm³.

Keywords: Formula Student, intake, engine power

1. INTRODUCTION

In classical internal combustion piston engines, the function of the intake system was to bring refrigerant to the cylinder engine while maintaining the smallest possible flow resistance, with the aim of obtaining a large ratio of filling cylinders. The flow resistance factor depended on the shape of the intake manifold, the length and shape of the intake ducts, and the air filter, which is an indispensable piece of equipment in the intake system. The intake system of the internal combustion engine was designed in such a way as to provide

¹ 4Turbo, Rzepakowa 1A Street 40-541, Katowice, Poland. Email: t.markiewicz@4turbo.pl.

² Faculty of Transport, Silesian University of Technology, Krasinskiego 8 Street, 40-019 Katowice, Poland. Email: lukasz.kaczmarczyk@gmail.com.

³ Faculty of Transport, Silesian University of Technology, Krasinskiego 8 Street, 40-019 Katowice, Poland. Email: pawel.fabis@polsl.pl.

a suitable amount of air to the engine during its operational cycle at any speed. When designing the intake system for *not charge* engines, which predominantly operate under negative pressure, it should be taken into account that the wave motions are generated as a result of the movement of the piston towards the bottom dead-centre position. However, in the case of supercharged engines, which almost always work under hypertension, it is important to carefully select the size of the plenum and the size of the inlet channels at the design stage [14]. Properly designed intake systems should allow for the uniform filling of all cylinders.

2. INLET SYSTEM OF THE TURBO ENGINE

The role of the intake manifold is to supply air to the head of the spark-injection engine, while the amount of moved air is adjusted by a throttle valve, which is part of the system. An essential element of the intake manifold is an air chamber, which acts as a plenum from which the individual cylinders absorb air. Runners, or short intake channels, represent the second element, which are an extension of the inlet head and combine the opening of the plenum. In the case of the plenum, it is necessary to take into account the following important factors:

- capacity
- uniformity of the air supply to the individual cylinders
- shaping the opening (inlet) of the individual runners to achieve the maximum flow [2]

The basic shape of the intake manifold is determined by its use. Typically, the manifold is followed by a damper, which is placed in front of the so-called air chamber, along with the plenum, which supplies air to all the cylinders.

One advantage of the damper cylinder is the smaller flow losses, which means that it is more suitable to use maximum power. In the case of a throttle being placed before the manifold, accuracy is increased, such that you can control the fuel injection and ignition at low engine speeds, which makes this solution more suitable for road vehicles. A preferred situation has also been designed for the intake manifold of a road vehicle in such a way that the damper is placed centrally between the channels of [1].

The most important role of the plenum is to compensate the airflow to the individual cylinders. Unfortunately, car manufacturers use a compact, aesthetically pleasing layout, locating the air intake on one end. This is not a problem at the design stage when topping up the engine plenum, but when the airflow starts to rapidly increase in real situations, a large disturbance ensues, which results in uneven delivery to the air cylinder [2]. The arrangement of individual dampers with a single throttle involves two different applications, but with many features in common. In both cases, the inlet, which takes air to the intake ports, should ideally comprise short runners into the combustion chamber. The size of the cone relative to the inlet runners should be prudently selected.

Figure 1 shows how the shape of the intakes of the runners impacts on the speed of the airflow. On the left side, you can see the speed of the flow in the event of the termination of a simple tube, while the right tube forms a conical or bell shape [9].

The length of the runners has a significant impact on the amount of air that enters the combustion chamber when the intake valve is opened and the engine is not running under pressure (top up). In turbocharged engines in general, the best results are obtained using long runners, which will result in a wide range of flat torque curves at low speeds, while the turbocharger will maintain a relatively high power at the end of the curve [1]. The literature contains information certifying that the runner is a tool for controlling the engine, given that the diameter and the length influence the shape of the power curve.

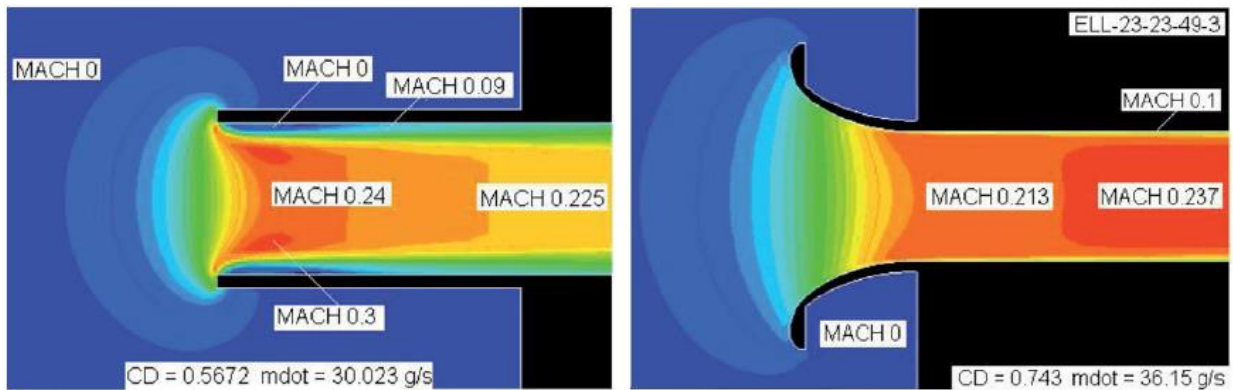

Fig. 1. Comparison of velocity flows for a simple inlet (left side) and a cone inlet (right side); mdot: mass flow per second [9]

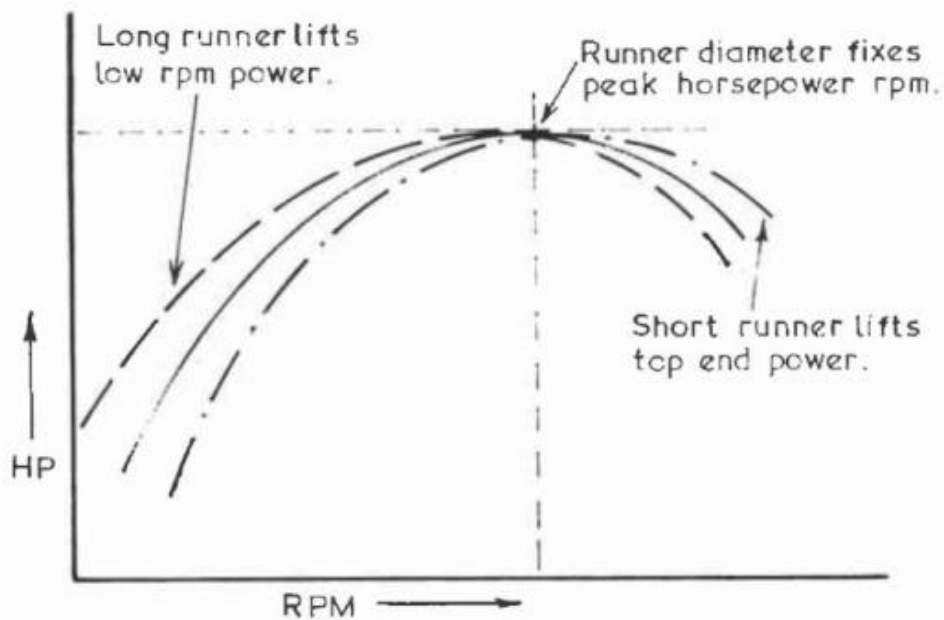

Fig. 2. Chart of the influence of the diameter and the length of a runner on engine power [2]

In principle, the diameter will involve a fixed rotation, in which the engine produces maximum power to the extent that the thick runner allows the engine to freely download air at high speed, while reducing power to the lower range. The length of the channels enables the extension of the power curve in the vicinity of the point determined by their diameter (Fig. 2). Short runners work in an opposite way: i.e., lower power and torque in the lower range help the engine to maintain power through the peak [2]. One of the important points in the design of the intake manifold is the connection between plenum and runners, which is the place where the inlet openings to the runners should be chosen carefully, with the most preferred combination resulting in the formation of a hole in the bell-shaped inlet, or “trumpet” [1].

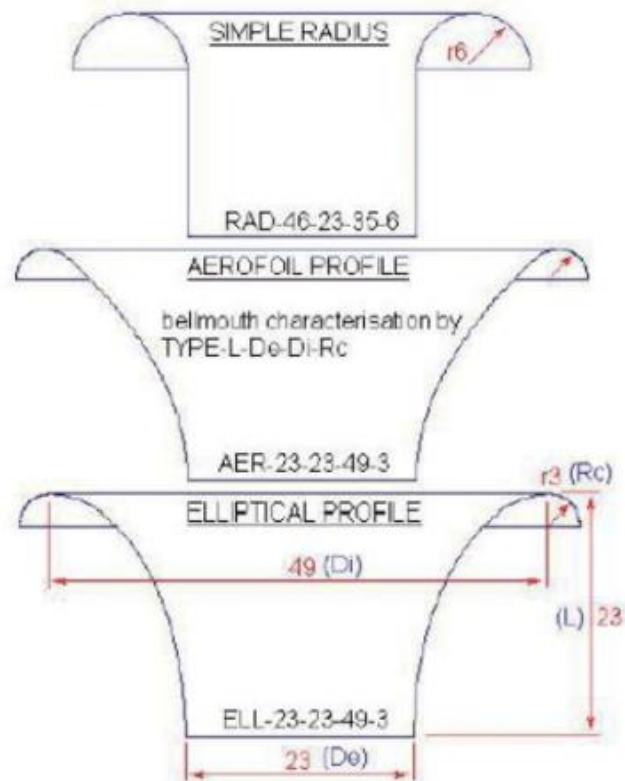

Fig. 3. Signing and shape of inlet ends [9]

The construction of the bell inlet or so-called “trumpet” in the internal combustion engine’s end runner intake piston has been copiously addressed in the technical literature. Modern computational fluid dynamics offer the possibility or even the ability to carry out computer simulations to determine the optimal shape of “trumpets”. Figure 3 shows three types of bell-shaped inlet runner, which have been analysed. Each type of bell is characterized by fundamental values such as L (length), Do (diameter output), Di (diameter input) and R (radius zone) (Fig. 4). There are different bell types: they may involve a straight pipe, the normal radius of an aerodynamic profile or that of an elliptical profile. During Blair’s analysis, a wide range of diameters and dimensions was tried and tested for each type of bell. Figures 6a-c represent the Mach number (speed of particles) for a normal radius and an elliptical profile.

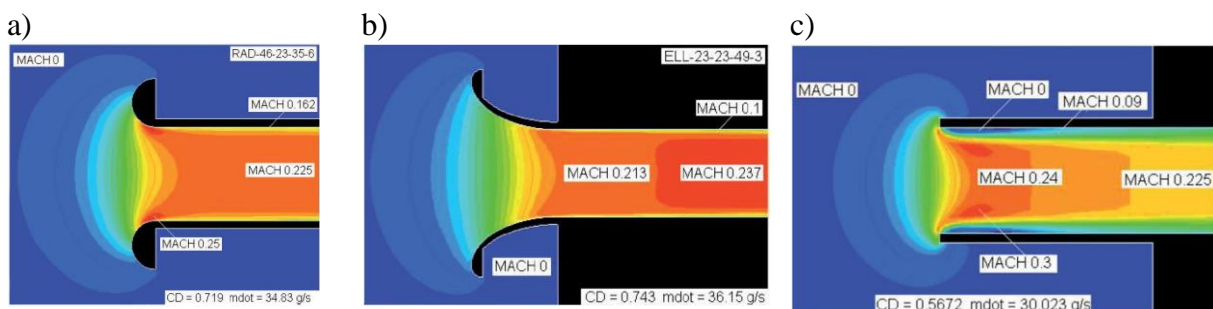

Fig. 4. Velocity stream flows and their decomposition for: a) fillet pipe, b) elliptic profile and c) straight pipe [9]

Simple rounding (Fig. 4a) shows a significantly smaller contraction stream, which is evident for a straight pipe (Fig. 4c). In contrast, an elliptical profile hardly narrows the stream, which means that the flow is smooth and even. Additionally, as shown in Figure 4c, when the tube terminates in a straight, sharp dissection, the influence coefficient is 0.5672 and the measured mass flow rate is 30,023 g/s. As seen in Figure 4a, when the inlet end is rounded with an ordinary radius, the influence coefficient is 0.719 and the mass flow is 34.83 g/s. In Figure 6b, when the bell is more refined, the elliptical profile's drag coefficient is 0.743 and the measured mass flow is 36.15 g/s. Considerable increases are observable in the flow rate (27%) and the mass flow (16%) due to the addition of even a simple rounding at the end of the inlet tube. A properly designed bell inlet runner has a better flow rate of 3.5% compared to the normal rounding runner connection with a plenum manifold. In terms of design, it is noted that a low and large outer diameter bell mouth is the most optimal solution. The length L of the bell should be equal to the initial diameter D_0 , while the entry diameter D_i should have a starting material diameter of 2.13. While the literature does not provide any analysis of rounding, authors have nevertheless suggested that rounding should have a diameter input of 0.08 [9]. Based on all the information collected while designing the intake and its components, a Student Formula-class first-intake manifold vehicle, known as WT-02, was created.

3. INLET MANIFOLD CONSTRUCTION FOR THE FORMULA STUDENT CAR

The object of the research is the Formula Student racing class vehicle WT-02, equipped with a four-cylinder, four-stroke spark-ignition engine, which has a capacity of 600 cm³. Although this engine was originally powered by a carburetted system, in the course of adapting the vehicle, the engine was converted to a multipoint injection system.

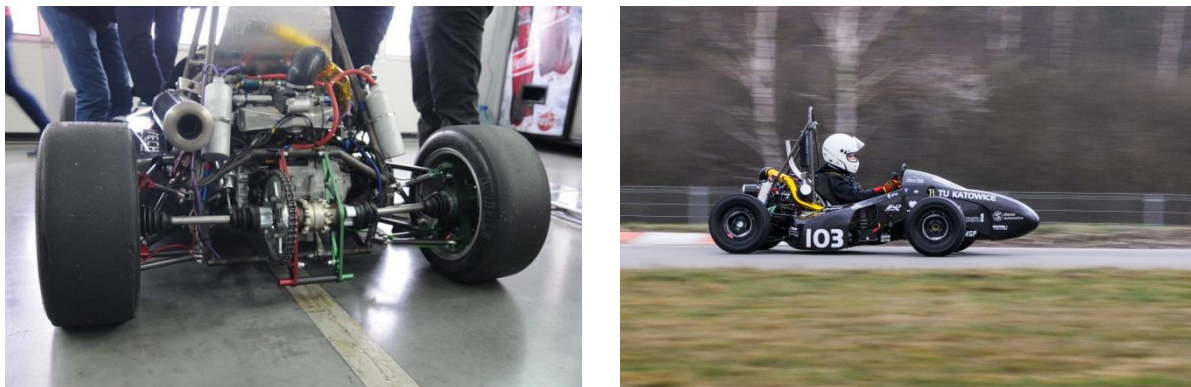

Fig. 5. View of the car and engine

During the project construction, in order to increase the dynamic qualities of the vehicle, a charging system using a turbocharger was applied. The test engine and vehicle are shown in Figure 5.

The students involved on the project made modifications to the engine intake system, while the inlet manifold was designed using the SolidWorks CAD program. The priority was to create a modified intake manifold, which would result in a high-power supercharged engine and be characterized by low flow resistance.

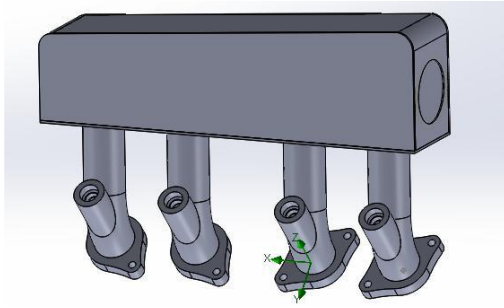

Fig. 6. Inlet manifold (Version I) before optimization

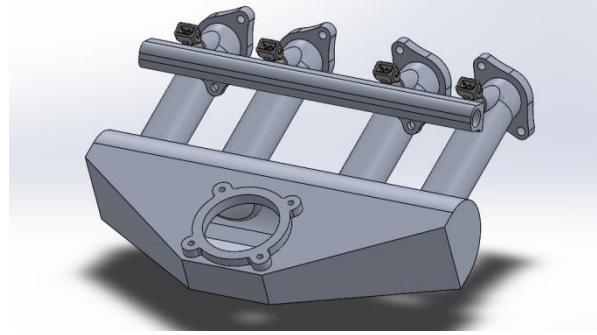

Fig. 7. Inlet manifold (Version I) after optimization

We originally used a compact manifold (Version I) (Fig. 6), so that the entire intake system would fit in the frame of the vehicle and satisfy the requirements of the Formula Student competition rules. This involved a charge air cooler mounted on the right side of the vehicle, which also determined the location of the intake manifold. The manifold was attached directly to the throttle and fuel strip using fuel injectors. After analysing a number of solutions in the literature on the design of an intake manifold, we selected the design as shown in Figure 7. In this manifold, we changed where the throttle was fixed and used a bell-shaped inlet at the entrance to each runner. The use of such a solution should allow for a reduction in the coefficient of flow resistance.

4. FLOW SIMULATION RESULTS

Flow simulations were carried out for two intake manifolds. The analysis was carried out in relation to the inlet side manifold (Version I) and the central inlets (i.e., “trumpets”) that had formed in the so-called runners (Version II). In time-mapping the engine and the first road tests, it was noted that, in the engine equipped with a lateral inlet manifold, a smaller amount of air was supplied to one of the cylinders.

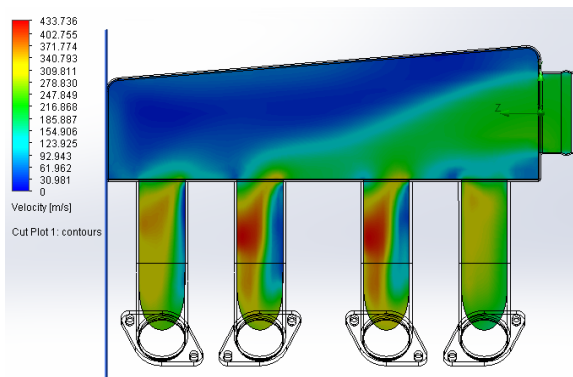

Fig. 8. Visualization of the parts' flow velocity

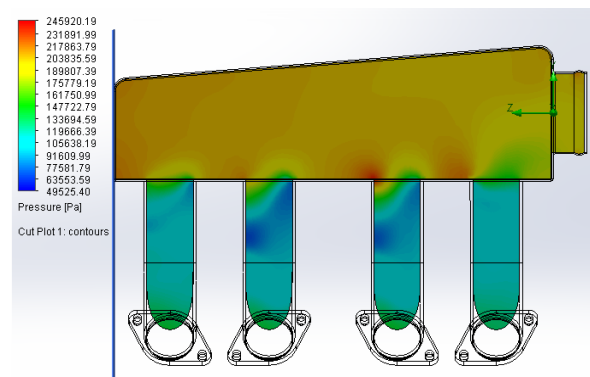

Fig. 9. Visualization of pressure decomposition

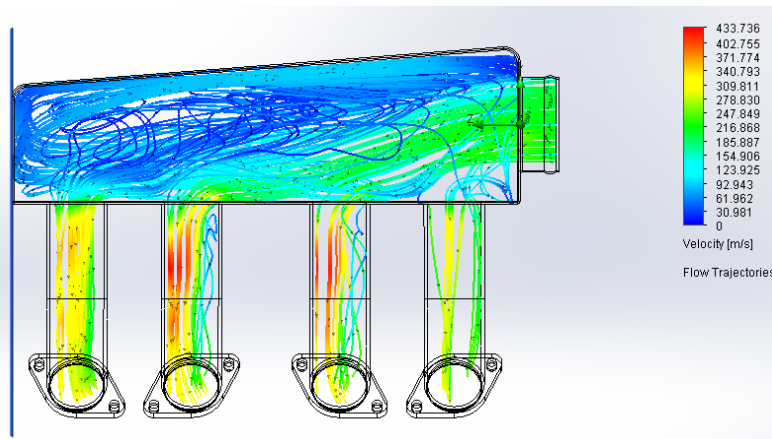

Fig. 10. Movement of the parts inside the manifold

The study was conducted using the Flow Simulation Solid Works 2014 package (academic version). The set pressure corresponded to the current inlet pressure of the engine or a 1.0 bar at the manifold outlet (inlet to the cylinder) when the simulation of atmospheric pressure prevailed.

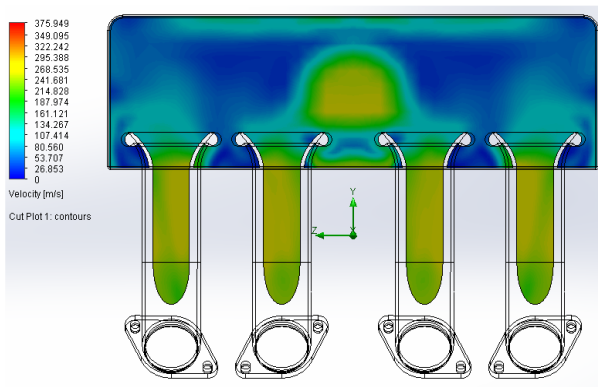

Fig. 11. Visualization of the parts' flow velocity

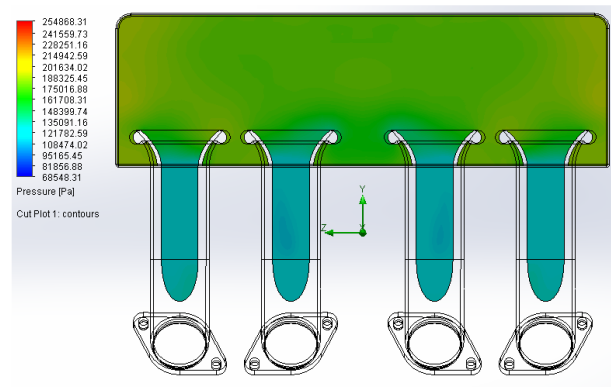

Fig. 12. Visualization of pressure decomposition

Figures 11-13 show the results of the flow simulation for the second version of the engine intake manifold.

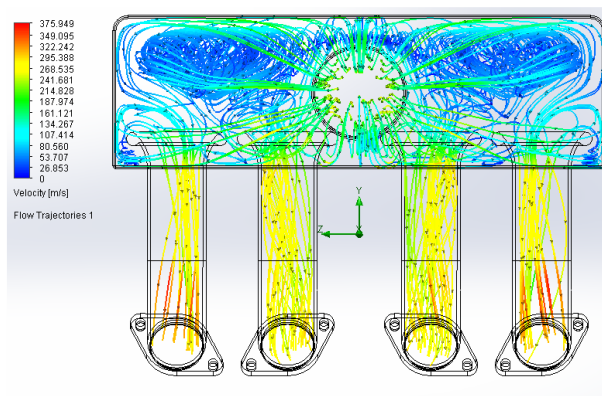

Fig. 13. Movement of the parts inside the manifold

A visible improvement in the second version of the inlet manifold provided a uniform distribution factor for each cylinder of the engine. In addition, there was an improvement in the uniformity of pressure distribution throughout the volume of the manifold.

5. RESEARCH RESULTS AND DISCUSSION

The simulations allowed us to determine the maximum flow rate factor for both versions of the intake manifold. Figure 14 shows the results of the maximum flow velocity for each cylinder.

a) Flow velocity [kg/s]

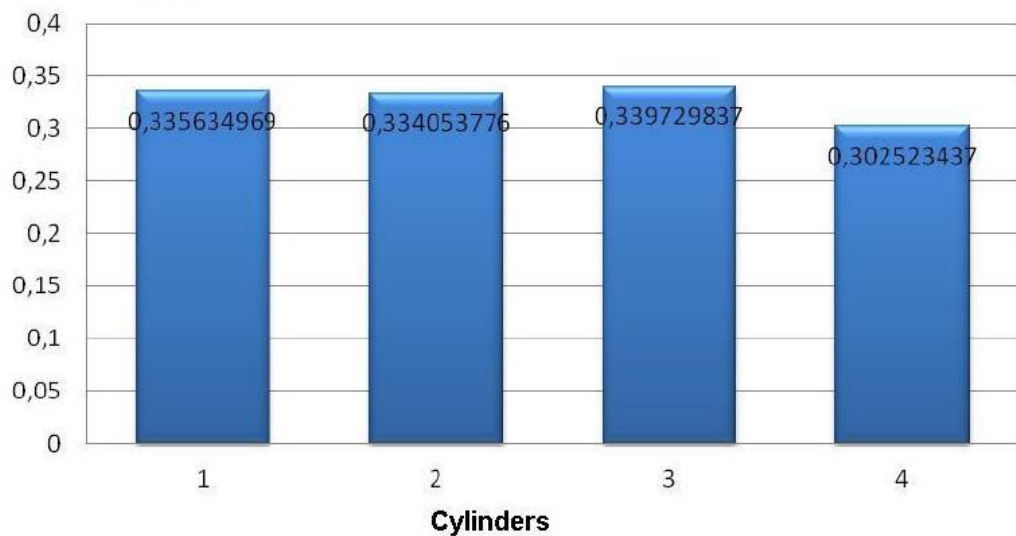

b) Flow velocity [kg/s]

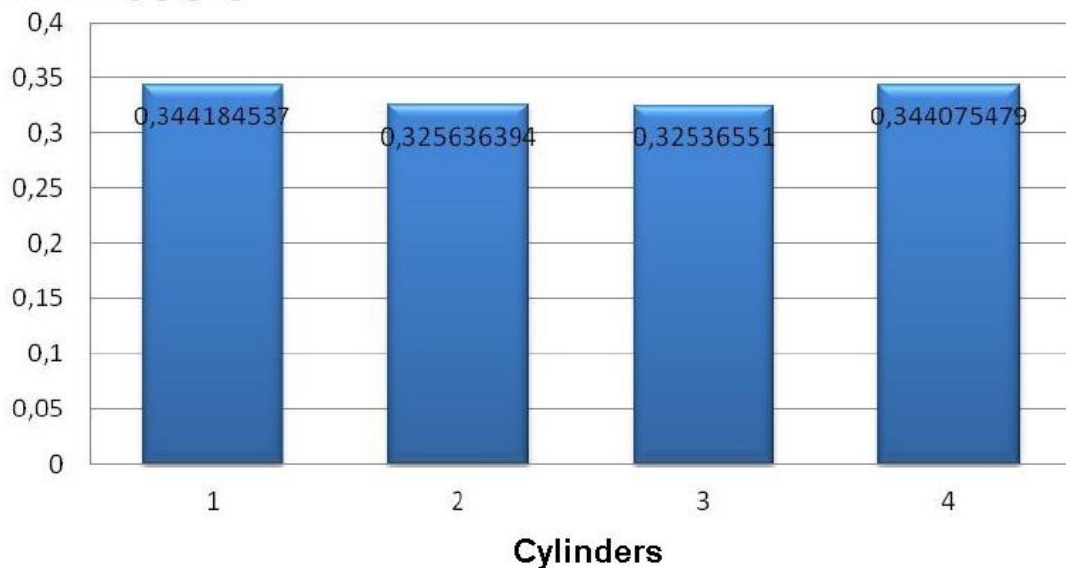

Fig. 14. Maximum flow velocity for the manifold: a) Version I and b) Version II

An improvement in the velocity distribution in each runner is visible, while the maximum value of flow velocity can be more clearly observed. The improvement in the medium flow through the intake manifold in turn improves the filling factor, while increasing the output parameters of the engine. Figure 15 shows the external characteristics of the engine manifold used in Versions I and II.

The maximum torque and maximum power are shown in Table 1.

Tab. 1

Comparison of the engine parameters

Parameters	Inlet manifold Version II	Inlet manifold Version I
Power [kW/KM]	103.3/141.5	74/100
Torque [Nm]	128,7	104.2
Power RPM [min^{-1}]	8,227	7,734
Torque RPM [min^{-1}]	7,285	5,930

The measurements obtained using a chassis dynamometer, as shown in Table 1, confirm the changes in the intake of the engine, the effect of which is a significant increase in power and torque, as well as an increase in the dynamics of the vehicle movement.

6. CONCLUSIONS

Simulation studies were carried out on the bench, with the vehicle driven by a ZI engine, in order to make design changes to the intake system, evaluate the influence of the intake manifold's structure on the performance of the vehicle and engine, and observe changes in the flow of refrigerant through the intake manifold. The research produced the following conclusions:

1. Introducing the central inlet manifold caused an alignment of factors discussed in the chapter among individual channels (runners). This resulted in a uniform operation of the engine in terms of idle speed.
2. The use of bell-shaped inlets, also known as "trumpets", increased the flow rate through the intake manifold. A 3% increase in the flow velocity was registered in relation to the collector-free trumpets and the inlet side refrigerant.
3. Changing the structure of the intake manifold can result in an increase in power and torque. Engine power increased by 39% and torque by 23.5%.

It seems reasonable, therefore, to continue research on the optimization settings of the engine and reducing the resistance of the flow through the intake system.

a)



1446 — Pwr 73,5 KM @ 7207,0 rpm Tq 72,3 Nm @ 6916,0 rpm
07.2015 WT 01 SILESIA AUTOMOTIVE
RUN 2 — Pwr 100,0 KM @ 7734,0 rpm Tq 104,2 Nm @ 5930,0 rpm
07.2015 WT 01 SILESIA AUTOMOTIVE SILESIA AUTOMOTIVE

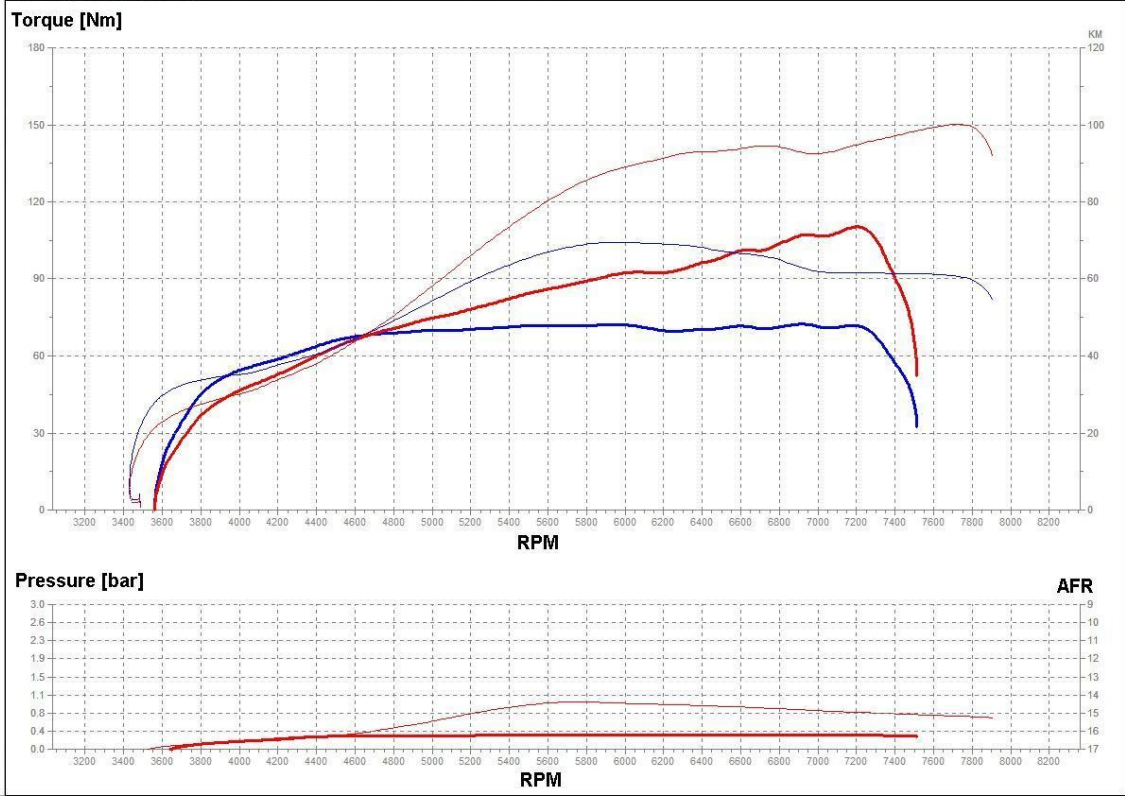

b)



RUN 1 — Pwr 141,5 KM @ 8227 rpm Tq 128,7 Nm @ 7285 rpm
11.2016 SILESIA AUTOMOTIVE WT-02 160R01

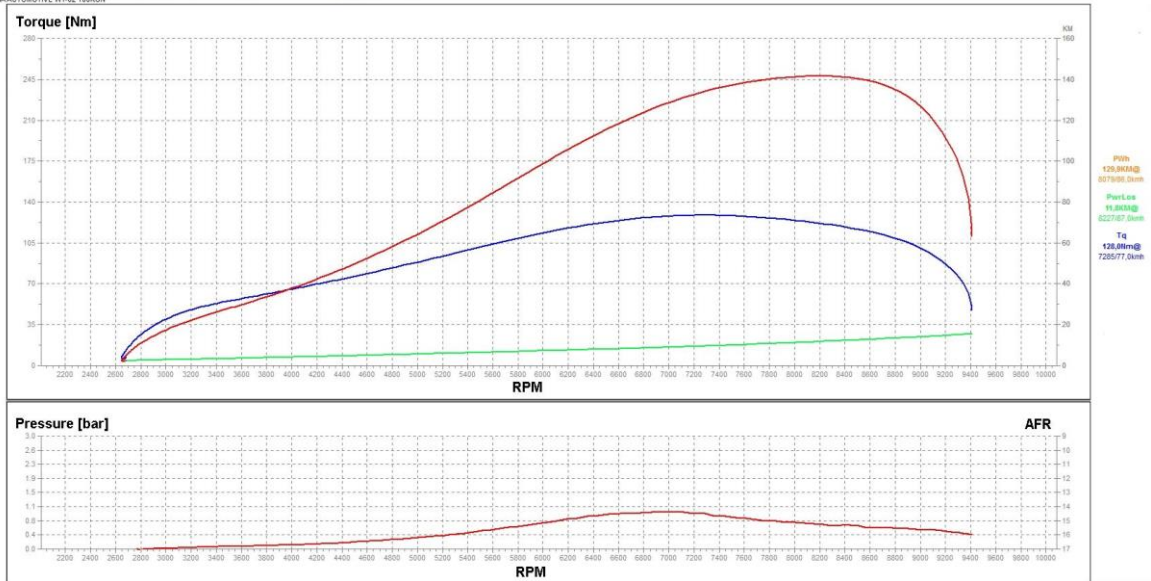

Fig. 15. Maximum power and torque charts for the manifold: a) Version I and b) Version II

References

1. *Systems*. Cambridge: Robert Bentley, Inc.
2. Bell A. Graham. 2002. *Forced Induction Performance Tuning: A Practical Guide to Supercharging and Turbocharging*. Sparkford: Haynes Publishing.
3. Kordziński Czesław, Środulski Tadeusz. 1968. *Inlet Systems of Combustion Engines*. Warsaw: Publishing Communications and Associations.
4. Luft Sławomir. 2003. *Fundamentals of Engine Construction*. Warsaw: Wydawnictwa Komunikacji i Łączności. ISBN: 9788320618068.
5. Mysłowski Janusz. 2006. *Engines Charging*. Warsaw: Publishing Communications and Associations. ISBN: 978-83-206-1964-5.
6. Zając Piotr. 2009. *Car Engines*. Warsaw: Publishing Communications and Associations. ISBN: 978-83-206-1735-1.
7. Zając Piotr. 2010. *Car Engines: Fuelling, Cooling, Oiling, Inlet and Exhaust Systems*. Warsaw: Publishing Communications and Associations. ISBN: 978-83-206-1783-2.
8. Zając Piotr, Leon Maria Kołodziejczyk. 2001. *Combustion Engines*. Warsaw: School and Pedagogical Publishing House. ISBN: 9788302079870.
9. Blair Gordon, Melvin Cahoon. 2006. *Race Engine Technology Magazine*. Simon Moss Publishing, September, p. 36-41.

Received 14.11.2016; accepted in revised form 15.01.2017



Scientific Journal of Silesian University of Technology. Series Transport is licensed under a Creative Commons Attribution 4.0 International License