

NUMERICAL ANALYSIS OF COLLISION BETWEEN LOCOMOTIVE AND PASSENGER CAR LOCATED ON LEVEL CROSSING

Piotr Szurgott, Paweł Dziewulski

*Military University of Technology
Department of Mechanics and Applied Computer Science
Gen. Sylwestra Kaliskiego Street 2, 00-908 Warsaw, Poland
tel.: +48 22 6839947, +48 22 6837610, fax: +48 22 6839355
e-mail: pszurgott@wat.edu.pl, pdziewulski@wat.edu.pl*

Abstract

The main aim of this study is to carry out dynamic finite element analysis of a collision between shunting locomotive and a passenger car. Numerical simulations include side impact of the running locomotive in the vehicle situated across the track on a level crossing. A considered locomotive based on a popular diesel-electric shunting locomotive SM42 but it was slightly modernized in comparison with the original. Finite element model of the locomotive was developed by the authors whereas the vehicle FE model was download from the National Crashworthiness Analysis Center database and it was dedicated to the crash/impact analyses. FE analysis was carried out according to the PN-EN 15227 standard which provides crashworthiness requirements for railway vehicle bodies. However, additional objective of the analysis was to evaluate the behaviour of a small passenger car during the side impact with about 70-ton locomotive. A subcompact passenger car – Geo Metro – was selected as a representative for the study. One of the design collision scenario impact into low obstacle for railway vehicles operated on national and regional networks. LS-DYNA computer code was used for the simulations. The paper presents selected results of analysis generally focused on the locomotive frame behaviour. Contour of stress for the moment of time is presented. Moreover, time histories of selected parameters are depicted. The energy balance was also checked in order to confirm the accuracy of analysis.

Keywords: *finite element method, dynamic analysis, collision, railway vehicle, passenger car, LS-DYNA*

1. Introduction

The PN-EN 15227 standard [1] provides the crashworthiness requirements for railway vehicle bodies. Dynamic numerical simulation are acceptable since the experimental tests on the complete objects are impractical or sometimes impossible e.g. due to relatively high costs of research or availability of ready-made prototypes of railway vehicles. This study is focused on evaluation of the complete locomotive behaviour during the collision with low obstacle [1]. The current study is a part of the project focused on modernization of the SM42 locomotive. Therefore, it is required to evaluate the locomotive behaviour during the impact test.

Locomotive under consideration belongs to the C-I crashworthiness design category [1]. It is a railway vehicle designed to operate generally on national and regional networks which have level crossings. It means that such vehicles may interfere with road traffic. Therefore, it is necessary to take into account a following design collision scenario – a locomotive front end impact into low obstacle (e.g. car on a level crossing, animal, rubbish [1]). According to the mentioned standard, railway vehicle is supposed to be equipped in appropriate obstacle deflectors. Tested locomotive FE model does not have such deflector in the preliminary analysis. Despite this, obtained results are satisfying since the crashed vehicle did not get under the locomotive causing derailment. Simulation test was carried out for the velocity of 36 km/h. Current paper presents selected results of analysis generally focused on the locomotive behaviour. However, the behaviour of a subcompact car during the side impact with about 70-ton locomotive was also taken into account.

The current study is a part of the project focused on modernization of a popular diesel-electric shunting locomotive SM42 into a hybrid one. Therefore, the tested locomotive is slightly different in comparison with the original. All components above the locomotive frame could be freely configured according to the operator requirements. A chassis of the locomotive was essentially unchanged. Moreover, parameters of the installed hybrid module may be individually chosen for each locomotive on the basis of the actual power demand resulting from the operation characteristics.

2. Finite element modelling and analysis

Finite element models of vehicles under consideration are presented in Fig. 1. A locomotive FE model was developed by the authors and described in detail in previous work [2]. A subcompact car – Geo Metro – model was download from the Finite Element Model Archive available at the National Crash Analysis Center (NCAC) [3]. The locomotive frame was simulated as a deformable body with a fine mesh. Other components of the locomotive FE model were considered as rigid bodies mostly. Moreover, FE model does not include the skin plates. It allowed the authors to simplify the FE model and reduce the CPU time. Numerical model of the passenger car was dedicated to crash analysis therefore additional modifications were not necessary.

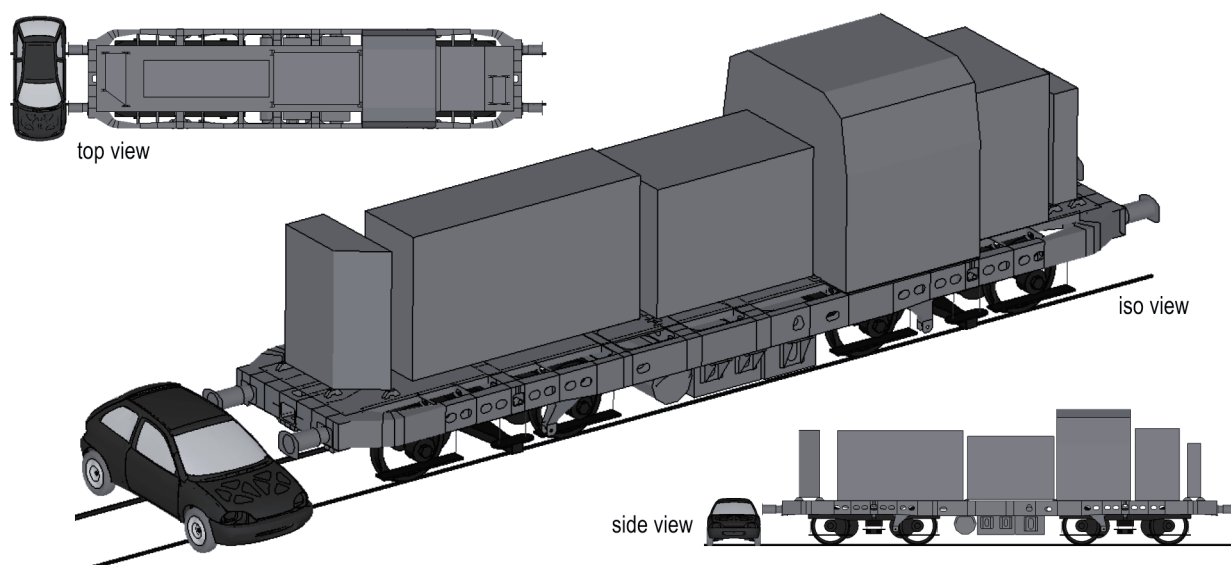

Fig. 1. FE model of the locomotive and the passenger car on a level crossing – FE mesh not shown

FE analysis was carried out using the LS-DYNA computer code. Both FE models were merged in HyperMesh software. The car was located on a track perpendicularly to its longitudinal axis. Rigid wall was applied to simulate a ground. The friction coefficient between tires and the ground was equal to 0.6. The locomotive was running on the track using initial velocity option. Velocity of 36 km/h (10 m/s) was applied to all nodes of the locomotive FE model. Summary of the complete FE model of objects under consideration is provided in Tab. 1. Masses of each model correspond to the mass of the designed locomotive (about 74 tons) and the mass of the vehicle (about 700 kg), respectively. Therefore, density of some components was modified and some lumped masses were added to the model to ensure its proper mass. Termination of the analysis was assumed at about 400 ms. Total CPU time was about 35 hours for two computers used.

General conclusion regarding the FE analysis is that proposed numerical model are stable. Analysis was not completed before the termination time and it was completed without errors. The authors obtained a proper energy balance depicted in Fig. 2 that confirms the correctness of the analysis. The energy ratio oscillates around unity.

Tab. 1. Summary of the complete FE model of the collision scenario between a locomotive and a passenger car

	Locomotive	Passenger car	Track	Total
Number of nodes	126 391	35 180	40 420	201 991
Number of element	115 677	31 925	16 160	163 762
– shell	96 550	31 095	—	127 645
– solid	19 099	820	16 160	36 079
– beam	28	10	—	38

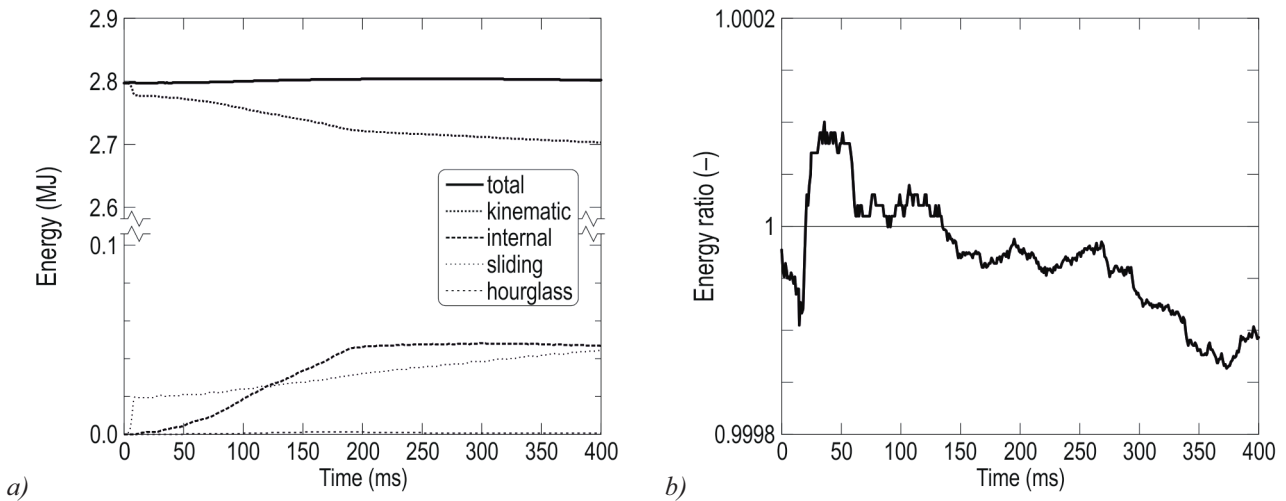

Fig. 2. Energy balance (a) and the energy ratio (b) obtained from the analysis for the complete FE model

3. Results of the FE analysis

Figure 3 shows time histories of velocity and acceleration. These two parameters were measured for the cab during the simulation. Locomotive velocity decreases slightly due to friction force between vehicle tires and the ground. The mean longitudinal deceleration in the survival spaces is not specified for this collision scenario. However, for the collision between the locomotive and the large deformable obstacle such as a truck, it shall be limited to 7.5 g [1]. Obtained results for the acceleration were filtered using SAE filter available in LS-DYNA postprocessor. Two filter frequencies for acceleration were assumed on the basis of similar simulation described in [4]. It can be noticed that the maximum deceleration do not exceed 1.7 g.

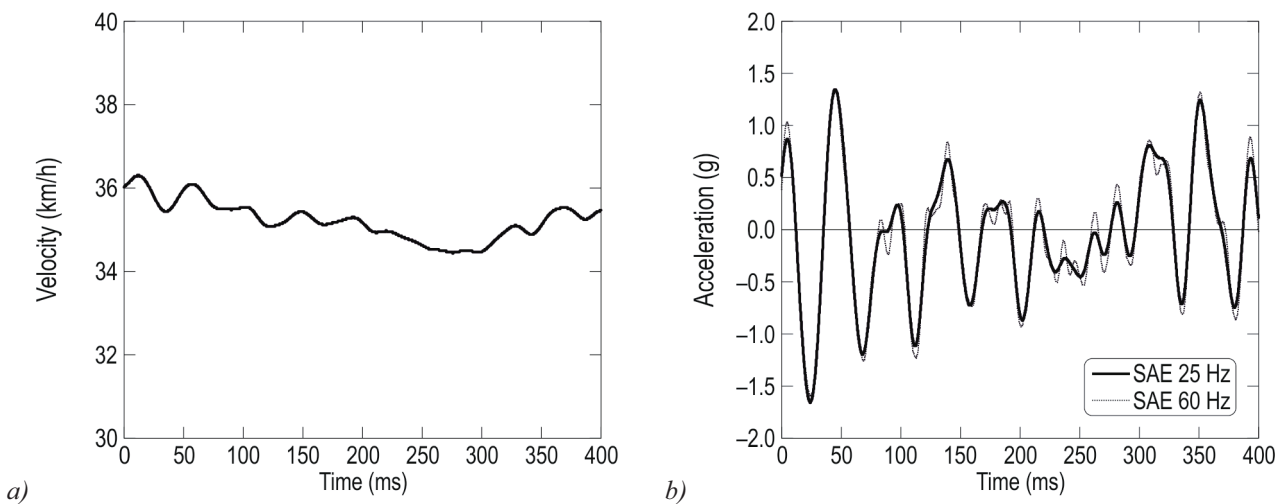

Fig. 3. Time history of the velocity (a) and the longitudinal acceleration (b) of the locomotive cab

Destruction of the car in the final stage of the analysis is depicted in Fig. 4. Despite of missing an obstacle deflector, a crashed vehicle did not get under the locomotive causing derailment. It is also confirmed by the time-history of the locomotive velocity (Fig. 3a) which decreases only slightly. It means that the car could be still pushed until any other obstacle was encountered on its way or to a complete stop of the locomotive. A separation between any wheelset and the rail head was not observed. Therefore, there is no risk of derailment of the railway vehicle.

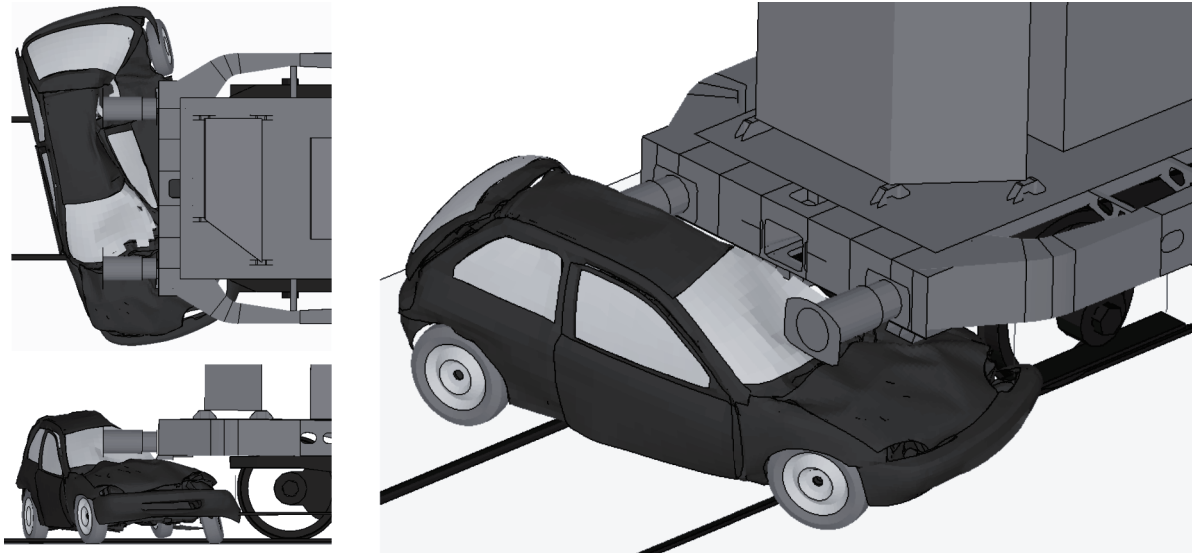

Fig. 4. Destruction of the car in the final stage of the analysis – after 400 ms

Energy absorbing mechanism for the locomotive was also taken into account. Fig. 5a shows buffers compression during the collision. It can be notice that only the right buffer was less than 20% compressed. The pad of the second buffer does not even touch the car body. Time history of the internal energy for the buffers and the frame is compared in Fig. 5b. Frame absorbs most of the energy since the buffers generally do not touch the obstacle. It would lead to excessive strains and permanent plastic deformations during the collision with larger obstacle. However, such situation will probably not occur in tested configuration with low velocity and light passenger car.

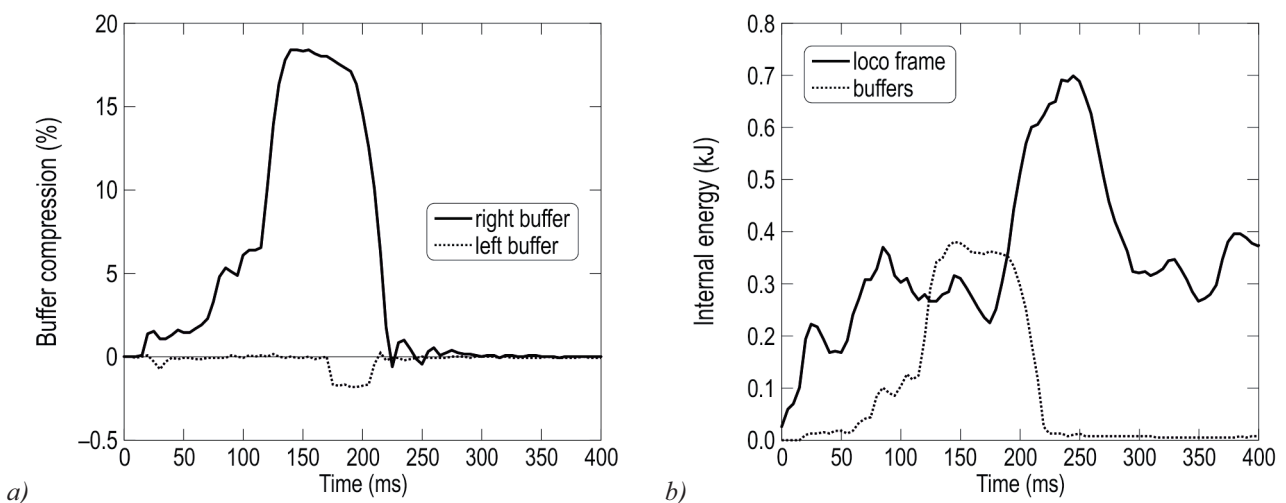

Fig. 5. Time history of buffers' compression (a) and internal energy of buffers and the locomotive frame (b) obtained from the FE analysis

Process of collision for selected moments of time is presented in Fig. 6 and 7. It can be seen that the locomotive practically move/push the car and destroy its body.

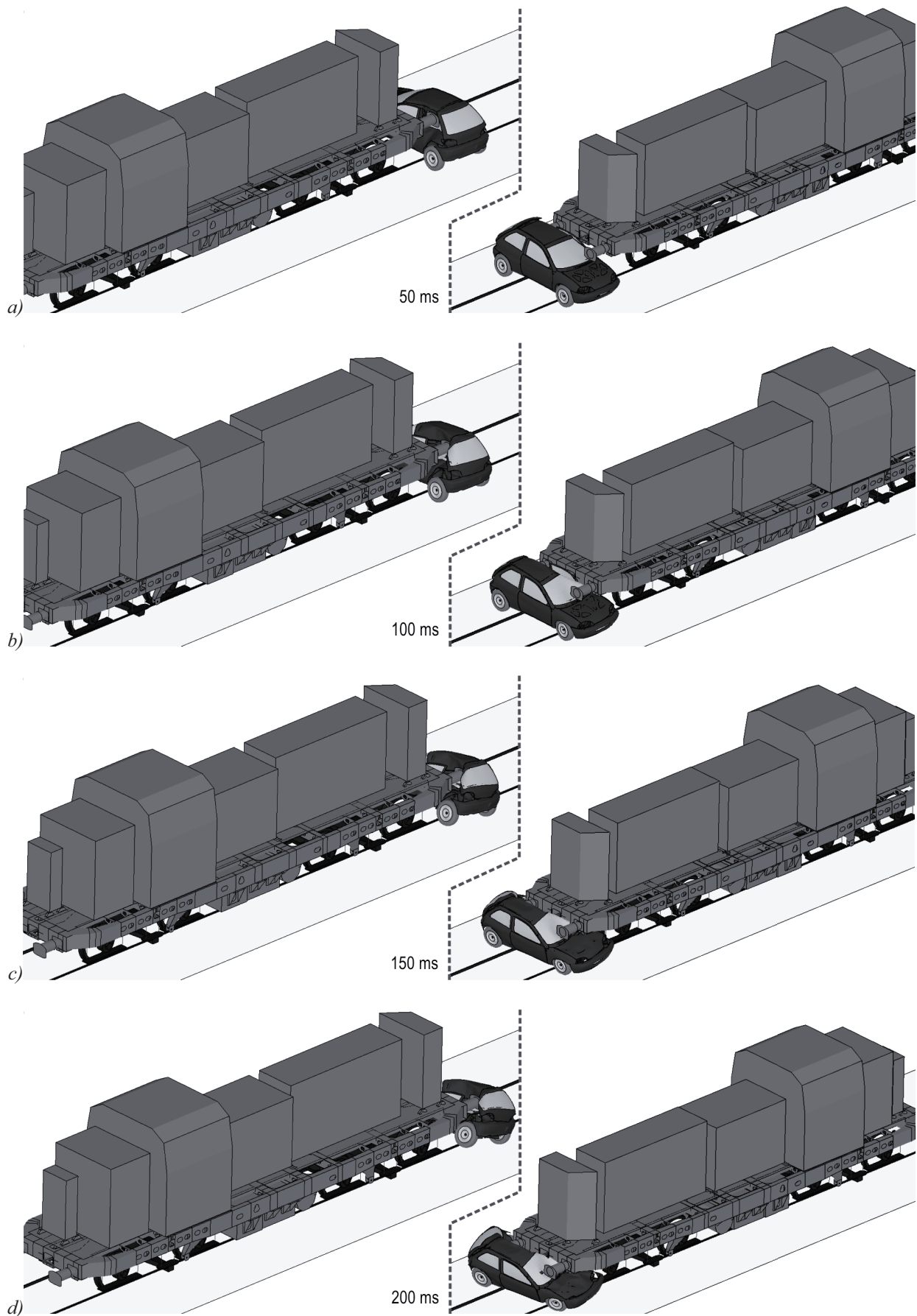

Fig. 6. Isometric views of collision between shunting locomotive and passenger car for selected moments of time: 50 ms (a), 100 ms (b), 150 ms (c), 200 ms (d)

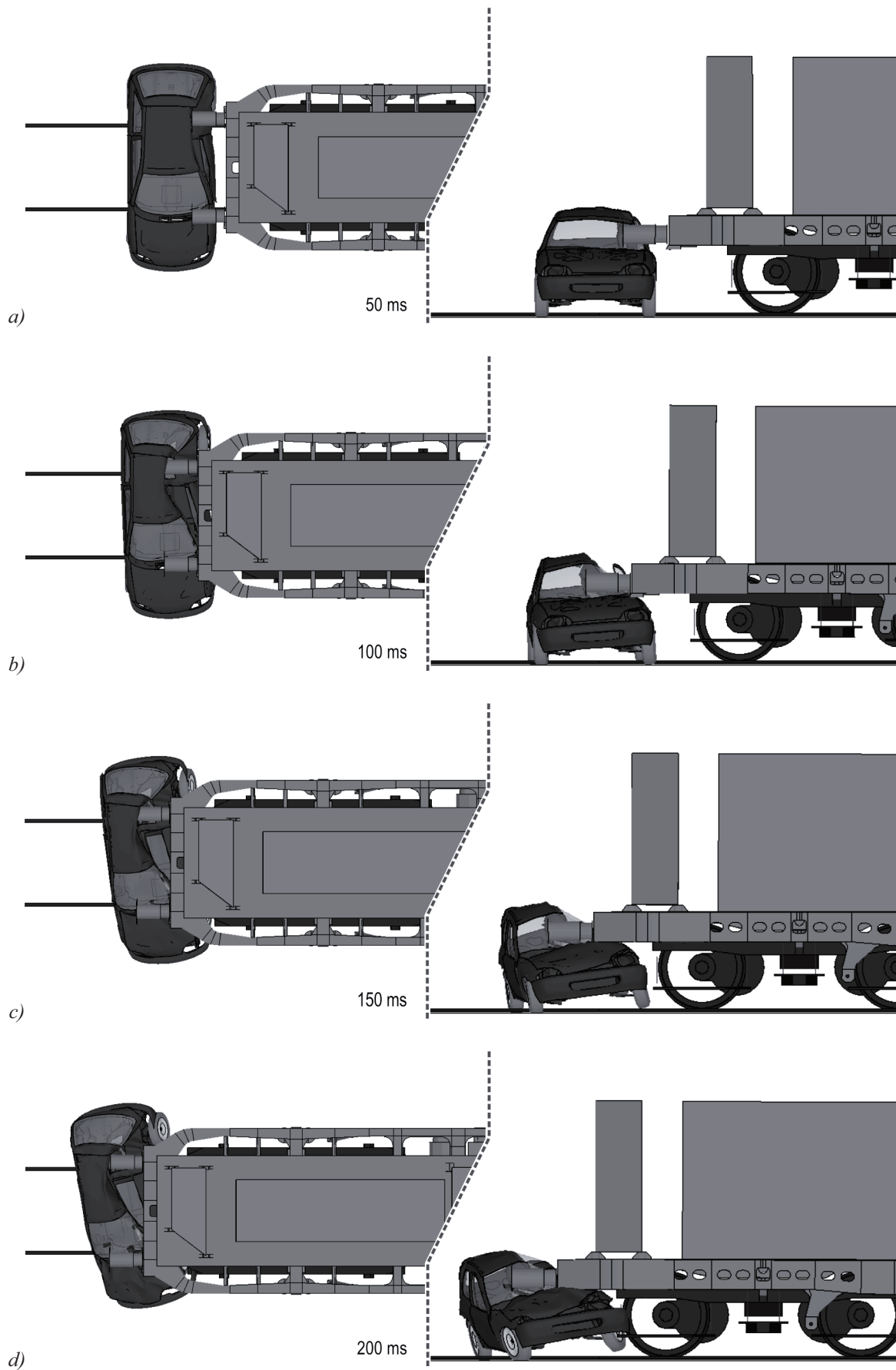

Fig. 7. Top and side view of collision between shunting locomotive and passenger car for selected moments of time: 50 ms (a), 100 ms (b), 150 ms (c), 200 ms (d)

Figure 8 presents contours of effective stress for the frame at the time of 150 ms. During the whole analysis values of the effective stress do not exceed 200 MPa in longitudinal and transverse members. However, a local 300-350 MPa stress concentrations can be observed especially at the intersection of steel profiles of the frame. Maximum value of the effective stress is lower than the yield stress of 600 MPa applied in the plastic kinematic material model used for the frame profiles. Therefore, there are no risk of plastic areas in the frame structure and permanently deformed sections, consequently. Relative changes in longitudinal distance between buffer attachments are depicted in Fig. 9. It can be concluded that the frame was not scientifically deformed in longitudinal direction during the collision.

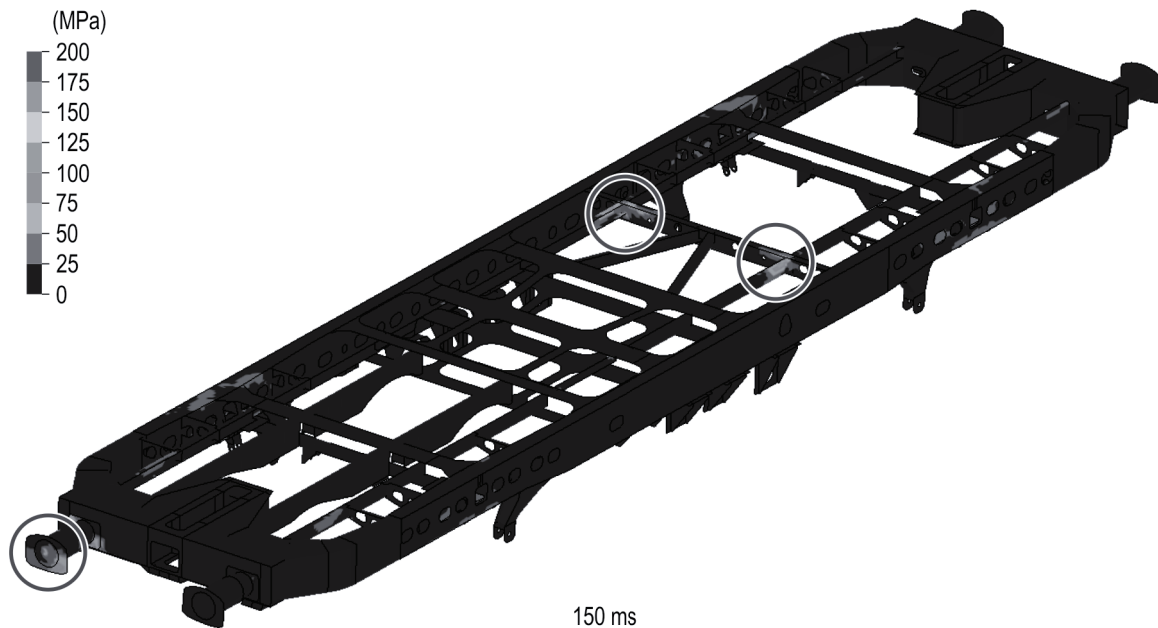

Fig. 8. Contours of the effective von Mises stress for the locomotive frame at the time of 150 ms; locations of the higher values of stress are marked

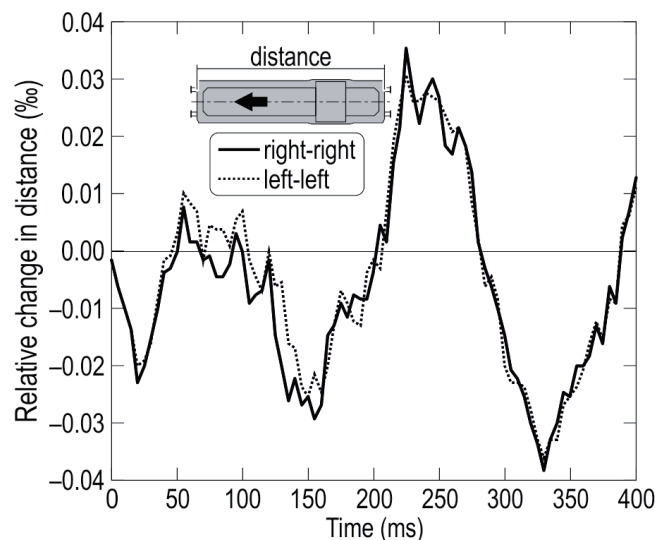

Fig. 9. Relative changes in longitudinal distance between buffer attachments

4. Summary and conclusions

The aim of this study was to carry out a dynamic finite element analysis of a collision between shunting locomotive and a passenger car. Numerical simulations include side impact of the running locomotive in subcompact car – Geo Metro – located across the track. Simulation test was

performed for the velocity of 36 km/h. Longitudinal deceleration for the locomotive cab does not exceed 1.7 g. During the collision locomotive practically move the car and completely destroy its body. The locomotive was generally not affected in the collision. Only one – right – buffer was compressed after contact with the car structure and absorb the impact energy. However, the energy is also absorbed by the frame, but low velocity in combination with the relatively low mass of the car does not lead to excessive strains and permanent plastic deformations. Measurements of the longitudinal distance between buffer attachments shows that collision does not cause the deformation of the locomotive frame. Maximum value of the relative change in distance is less than 0.04%. It means that base dimension of the frame may change by about 0.5 mm. The results provide qualitative and quantitative data related to the locomotive behaviour during the collision with low obstacle. It may be useful for the designer in further modernization of the considered structure. Despite of missing an obstacle deflector which is required for such railway vehicle, a crashed car did not get under the locomotive. Hence, there is no risk of derailment of the railway vehicle under consideration.

Acknowledgements

The study has been supported by the National Centre for Research and Development (Poland) under the Applied Research Programme as a part of the project PBS1/B6/5/2012, realized in the period of 2012–2014. This support is gratefully acknowledged.

References

- [1] PN-EN 15227+A1:2011 Standard, *Railway applications – Crashworthiness requirements for railway vehicle bodies*, Polish Committee for Standardization, Warsaw, Poland 2011.
- [2] Dziejulski, P., Szurgott, P., *Development of finite element model of shunting locomotive applicable for dynamic analyses*, Journal of KONES, Vol. 21, No. 3, 2014.
- [3] <http://www.ncac.gwu.edu/vml/models.html>, last retrieved on August 7, 2014.
- [4] *Full-scale locomotive dynamic crash testing and correlations: locomotive consist colliding with steel coil truck at grade crossing (Test 3)*, Final Report, U.S. Department of Transportation, Office of Railroad Policy and Development, Washington, United States 2011.