

# ANALYSIS ON THE MIXED FRICTION BETWEEN THE GUIDE MADE OF CAST IRON AND THE VALVE STEM MADE OF Ti6Al4V WITH AND WITHOUT PROTECTIVE LAYER

MACIEJ KUCHAR<sup>1</sup>, KRZYSZTOF SICZEK<sup>2</sup>

Lodz University of Technology

## Summary

Lightweight valves are commonly used in modern combustion engines with cam and camless valve train. They can be made of TiAl alloys and in particular the inlet valves can be made of Ti6Al4V. The stems of such valves can be coated by protective layer obtained by nitridation, chroming or the other one. The stems can mate with guides made of cast iron, of phosphor bronze or beryllium bronze. Mating can take place in conditions of mixed friction with different share of lubricated friction. The researches have been provided in the tribotester. The analyzed valve has been driven electromagnetically, for the different valve strokes and frequencies. The mating takes place in the condition of oil absence. The valve has been loaded by additional mass to induce the normal force between valve stem and its guide. It has been measured the acceleration and the displacement of the valve, the impact force of the valve into its seat insert, friction force between valve stem and its guide and the sound level. The aim of the researches is to obtain and compare values and courses of friction coefficient between the guide made of cast iron and valve stem made of Ti6Al4V for certain number of the valve strokes and frequencies. The researched stem could be uncoated or coated by Cr layer or by nitridation. The analytical model has been elaborated to calculate the contact pressure and the friction force between valve stem and its guide for the conditions of mixed friction occurring for the selected engine oil and the valve motion relative to its guide as obtained from the tribotester. The obtained dry friction coefficient values have been used in the model. Results of researches have been presented in the article.

**Keywords:** friction, tribotester, TiAl alloy, cast iron, protective layer

## 1. Introduction

Lightweight valves are commonly used in modern combustion engines with cam and camless valve train.

<sup>1</sup> Lodz University of Technology Department of Vehicles and Fundamentals of Machine Design, ul. Żeromskiego 116, 90-924 Łódź, Poland, e-mail: kucharma@p.lodz.pl, tel. +48 42 631 22 50

<sup>2</sup> Lodz University of Technology Department of Vehicles and Fundamentals of Machine Design, ul. Żeromskiego 116, 90-924 Łódź, Poland, e-mail: krzysztof.siczek@p.lodz.pl, tel. +48 42 631 22 50

Camless valve train can be realized using electromagnetic [1], electromechanical [2], electrohydraulic [3] or even electropneumatic [4] drives mounted on the cylinder head.

They can be of full design and made of TiAl alloys [5, 6] or of ceramic material like Si<sub>3</sub>N<sub>4</sub> [6]. They can be also of the hollow design and made of steel or of TiAl alloy. In particular the full inlet valves can be made of Ti6Al4V. The stems of such valves can be coated by protective layer obtained by nitridation, chroming or the other process. The stems can mate with guides made of cast iron, of phosphor bronze or beryllium bronze [7, 8]. Mating can take place in conditions of mixed friction with varying share of lubricated friction. The researches have been carried out in the tribotester. The analyzed valve has been driven electromagnetically, for the different valve strokes and frequencies. The mating takes place in the condition of oil absence. The valve has been loaded by additional mass to induce the normal force between valve stem and its guide. It has been measured the acceleration and the displacement of the valve, the impact force of the valve into its seat insert, friction force between valve stem and its guide, the temperature of the guide and the sound level. The aim of the researches is to obtain and compare values and courses of friction coefficient between the guide made of cast iron and valve stem made of Ti6Al4V for certain number of the valve strokes and frequencies. The researched stem can be uncoated or coated by Cr layer or by nitridation. The analytical model has been elaborated to calculate the contact pressure and the friction force between valve stem and its guide for the conditions of mixed friction occurring for selected engine oil and such valve motion relative to its guide as occurred in the tribotester. The obtained dry friction coefficient values have been used in the model.

## 2. Methods for Obtaining Valves

Currently, there are several methods for obtaining titanium valves made of TiAl alloys. One of them is a powder metallurgy. It allows to produce titanium rods for hot forging. Other titanium outlet valves are made by casting and rolling the Ti6Al2Sn4Zr2MoSi alloy. To increase the wear resistance of these valves the plasma carburizing is used [6].

Many titanium valves are produced by the initial forging and machining to final shape. Some design forms are met as two partially treated segments joined together by friction welding, and then machined to the final shape [5].

To ensure hard tip for valve stem it is used currently three methods: hardened steel cap, cap with ceramic coating, thin film coating by PVD technology [5].

Since titanium is a relatively soft material, the additive hardened caps are usually used. For the valve stem of diameter less than 7 mm, it is used hard coating for the stem tip to avoid impacts of friction nature in contact zone between the cup and the valve stem tip [5].

In the case of titanium valves with Stellite tip friction welded, such tip can be ground during the repair, but up to a maximum 0.015 - 0.020 mm [5].

### 3. The Friction Model and Tester

The researches have been made on the tester presented in the Fig. 1. It has been measured the values for impact force for valve impacting its seat insert (by sensor C7), for friction force between valve and its guide (by sensor C3), for displacement (by sensor C1) and acceleration (by sensor C2) of valve. Additionally the sound level has been measured by the sonometer C6 [4]. The temperature (from sensors C4 and C5) has been the room one. Measured values have been transmitted by control cassette C8 into computer C9 drive and registered there.

The method of calibration for measuring circuits has been described in [7].

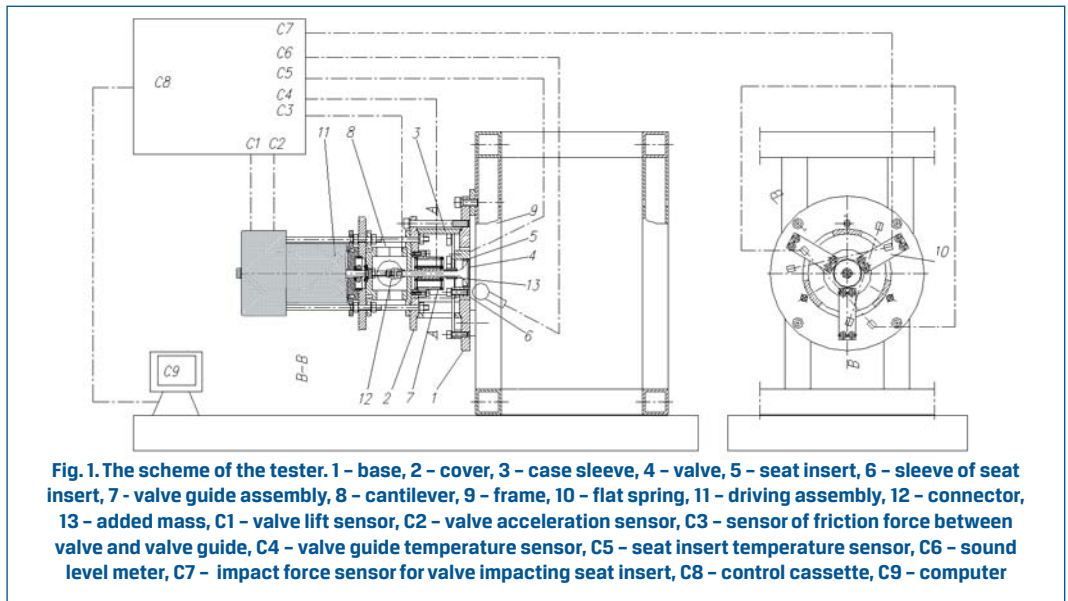

Values of friction coefficient  $\mu$  have been estimated from equation (1) [7]:

$$\mu = \begin{cases} \frac{T_R}{R} = \frac{T_R}{(m_v + m_a) \cdot g \cdot \frac{h_v}{h_v - (h_G + x)}}, & \text{for case a)} \\ \frac{T_R}{R_1 + R_2} = \frac{T_R}{(m_v + m_a) \cdot g \cdot \frac{h_g + 2(h_G + x)}{h_g}}, & \text{for case b)} \end{cases} \quad (1)$$

where:  $T$  - measured value of friction force between valve stem and its guide,  $R$ ,  $R_1$ ,  $R_2$  - reaction between the valve stem and its guide, depending on the case (Fig. 2),  $g = 9.81 \text{ m/s}^2$  - gravitational acceleration,  $x = (0 - 5) \text{ mm}$  - valve displacement,  $m_v = 19.7 \text{ g}$  - the valve weight,  $m_a = 0.4 \text{ kg}$  - the additional weight,  $h_v = 90 \text{ mm}$  - the valve length,  $h_g = 45 \text{ mm}$  - the guide length,  $h_G = 35 \text{ mm}$  - dimension between valve guide and weight centre of the valve - additional mass assembly (Fig. 2).

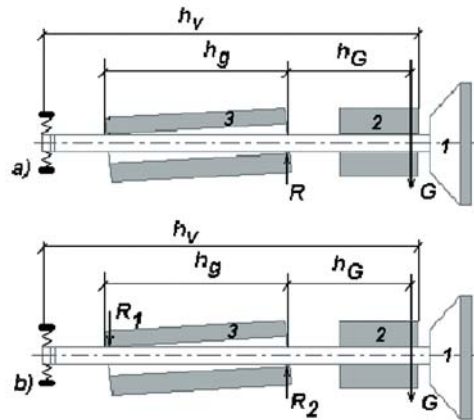

**Fig. 2. The scheme of loading for the valve - added mass - guide assembly; 1 - valve, 2 - added mass, 3 - guide; a) loading case, when reaction R between valve stem and its guide has existed in only one place, b) loading case, when reactions R1 and R2 between valve stem and its guide have existed in two places**

It has been elaborated model of the assembly consisted of the valve 4 and the movable coil 2 of the drive and presented in the Fig. 3. The displacement  $x$  of such coil parallel to the axis of the immovable part 1 of the drive is assumed to be in agreement with the displacement of valve obtained during its measurement in the tester. Such displacement is limited by the occurrence of the seat insert 7. The valve is loaded by additional weight 6 causing the force  $G$  perpendicular to the axis of the guide 5. The valve can also swing, by an angle  $\alpha$ , in the range limited by the clearance between valve stem 4 and its guide 5. Such swinging is allowed due to occurrence of the spherical joint 3.

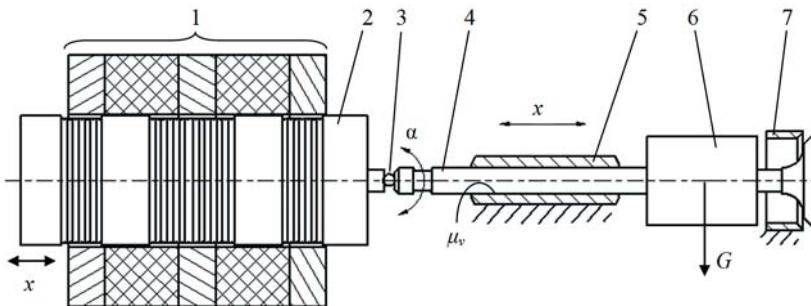

**Fig. 3. The model of the assembly consisted of movable coil the drive and valve bearing in its guide and loaded by additional weight; 1 - immovable part of the drive, 2 - movable coil, 3 - spherical joint, 4 - valve, 5 - guide, 6 - additional weight, 7 - seat insert**

The motion of valve caused the friction force  $T$ , which value is determined by the friction coefficient  $\mu v$  calculated from equation (2) and dependent on the friction coefficient  $\mu(v)$  obtained from the measured friction force and calculated velocity of valve motion against its guide and on the oil viscosity. The contact area of the shape similar to the elongated half-ellipse, has been treated as the sum of  $i$  small rectangles of the width  $b_i$  and the length  $l_i$ . Their values have been obtained iteratively during simulation.

$$\mu(t) = \frac{T_R(v)}{R(t)} \quad (2)$$

where  $T_R(v)$  – friction force calculated from equation (3) [8],  $R(t)$  – reaction in the contact zone between valve stem and its guide, obtained during simulation using the model from the Fig. 3.

$$T_R(v) = \mu(v) \cdot \sum_i b_i l_i \left[ \frac{(h_0 - h)}{c} \right]^{\frac{1}{m}} + \sum_i \eta b_i l_i K_R (v/h) \quad (3)$$

where:  $b_i$  – width of the  $i$ -th elementary rectangle,  $l_i$  – length of the  $i$ -th elementary rectangle,  $h_0$  – initial thickness of oil in unloaded contact zone,  $h$  – thickness of oil in the loaded contact zone,  $v$  – sliding velocity,  $\eta$  – dynamic viscosity of oil,  $c = 0.75$ ,  $m = 0.7$  – constant coefficients depending on the type of material and processing (grinding) of mating surfaces,  $K_R = 0.614$  – coefficient characterizing the hydrodynamic friction.

The thickness of oil  $h$  has been estimated from equation (4) [8], during iterative process of simulation.

$$\frac{dh}{dt} = - \left[ R(t) - \sum_i b_i l_i \left( \frac{h_0 - h}{c} \right)^{\frac{1}{m}} \right] \frac{h^3}{\eta b_{av}^2 l_{av}} - \left( - \sum_i 6 \eta b_i l_i^2 K_p \psi \frac{v}{h^2} \right) \frac{h^3}{\eta b_{av}^2 l_{av}} \quad (4)$$

where:  $b_{av}$  – averaged width of the  $i$ -th elementary rectangle,  $l_{av}$  – averaged length of the  $i$ -th elementary rectangle,  $K_p = 0.0265$ ,  $\psi = 0.06$  – coefficients characterizing the hydrodynamic interactions in contact zone, between grinded and polished surfaces.

## 4. Results of calculations

Obtained results of researches have been presented in the Figures 4-9. Measured values of valve lift  $h$  vs. time  $t$  have been shown in the Fig. 4. Valve stroke  $h_{max}$  has been equal 7 mm, 5 mm and 3 mm, respectively. Observed changes of valve position, during valve contact with its seat insert have resulted from the stiffness of the measuring set.

Measured values of valve acceleration vs. time have been shown in the Fig. 5. The maximum value equal up to 440 m/s<sup>2</sup> has been obtained during valve impact into its seat insert. For the case of valve stroke  $h_{max} = 5$  mm obtained values of acceleration during impact have been up to 30% higher than in the case of the  $h_{max} = 3$  mm. For the case of valve stroke

$h_{max} = 7$  mm obtained values of acceleration during impact have been up to 15% higher than in the case of the  $h_{max} = 5$  mm.

Measured values of the force  $F$  acting on the seat insert vs. time  $t$  have been presented in the Fig. 6.

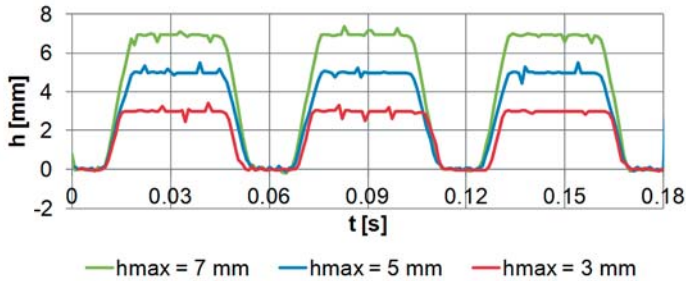

**Fig. 4.** Measured values of the valve lift  $h$  against time  $t$ ; loading frequency  $f = 16$  Hz, valve stroke  $h_{max} = 7$  mm,  $h_{max} = 5$  mm, and  $h_{max} = 3$  mm, respectively

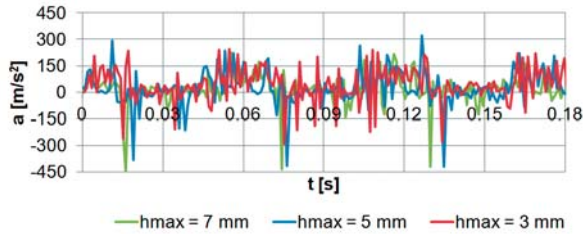

**Fig. 5.** Measured values of the valve acceleration  $a$  against time  $t$ ; loading frequency  $f = 16$  Hz, valve stroke  $h_{max} = 7$  mm,  $h_{max} = 5$  mm and  $h_{max} = 3$  mm, respectively

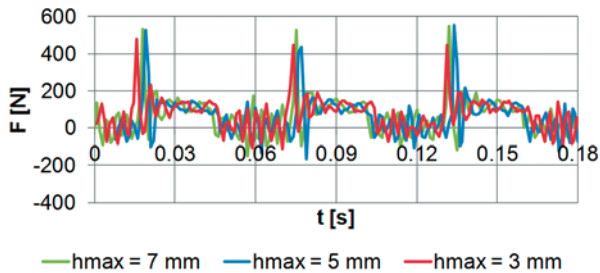

**Fig. 6.** Measured values of the impact force  $F$  between valve and its seat insert against time  $t$ ; loading frequency  $f = 16$  Hz, valve stroke  $h_{max} = 7$  mm,  $h_{max} = 5$  mm and  $h_{max} = 3$  mm, respectively

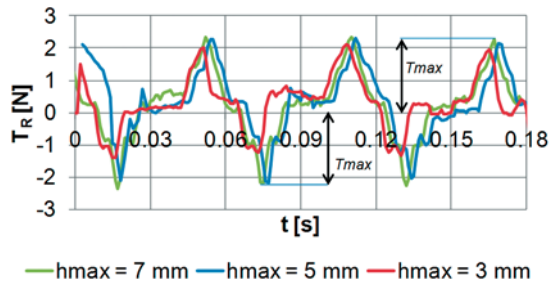

**Fig. 7. Measured values of the friction force  $T_R$  between valve and its guide against time  $t$ ; loading frequency  $f = 16$  Hz, valve stroke  $h_{max} = 7$  mm,  $h_{max} = 5$  mm and  $h_{max} = 3$  mm, respectively,  $T_{max}$  - maximum friction force during valve displacement against its guide**

For the valve stroke  $h_{max} = 3$  mm force during impacting the seat insert by the valve have been up to 23% smaller than in the case of the  $h_{max} = 5$  mm. For the valve stroke  $h_{max} = 5$  mm such force has been up to 17% smaller than in the case of the  $h_{max} = 7$  mm. It has been probably due to control algorithm of the tester. After the impact, the valve have been pushed into its seat insert by the force, which value has been equal 50 N. Measured values of friction force have been presented in the Fig. 7. Values, pointed  $T_{max}$ , obtained during rising and setting of valve have been slightly different. Observed changes in friction force values have been resulted from the stiffness of the measuring set. The maximum values of friction force in the case of valve stroke  $h_{max} = 3$  mm have been up to 25% smaller than in case of the  $h_{max} = 5$  mm. Such values in the case of valve stroke  $h_{max} = 5$  mm have been up to 5% smaller than in case of the  $h_{max} = 7$  mm.

Values of friction coefficient, calculated from equation (1) vs. time have been presented in the Fig. 8, for the case of non-coated valve. They have been obtained for loading frequency  $f = 16$  Hz, and valve stroke  $h_{max} = 5$  mm and their extreme values have been equal from 0.18 to 0.32.

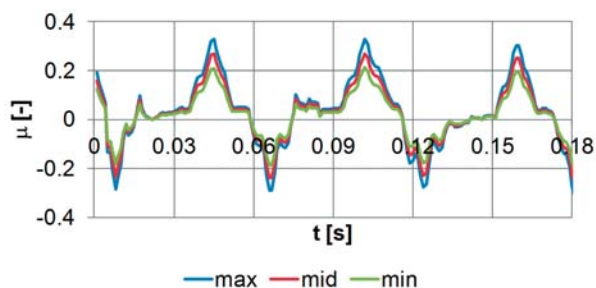

**Fig. 8. Calculated values of friction coefficient  $\mu$  between valve and its guide against time  $t$ ; loading frequency  $f = 16$  Hz, valve stroke  $h_{max} = 5$  mm**

The averaged values of friction coefficient vs. loading frequency have been shown in the Fig. 9. For all cases of testing they have decreased with frequency increasing, almost linearly.

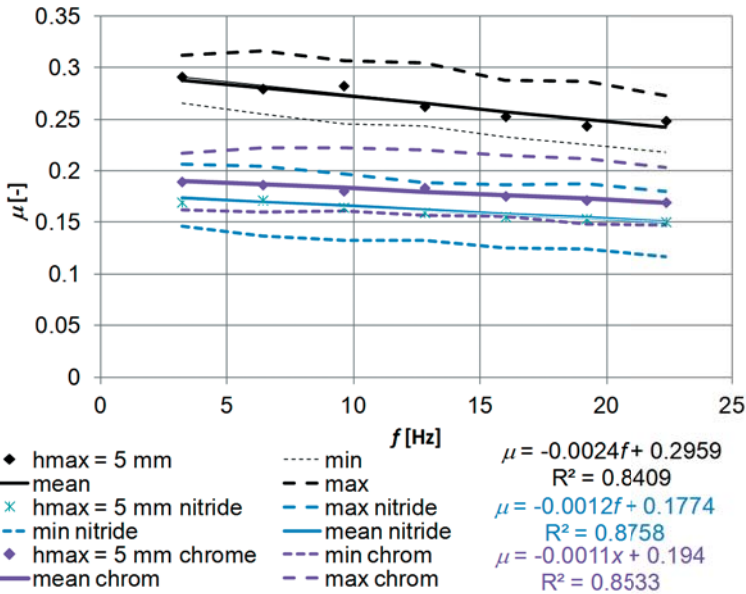

**Fig. 9. Calculated values of friction coefficient  $\mu$  between valve and its guide against loading frequency  $f$ ; valve stroke  $h_{max} = 5$  mm, valve uncoated, nitrided, coated by chromium layer**

The highest values of friction coefficient have been obtained in the case of tested uncoated valve stem made of TiAl alloy mating with its guide made of cast iron. Obtained values of the friction coefficient in case of valve stem coated by chromium are in the range (0.12-0.2) and are smaller than values in range (0.135 - 0.23) obtained for the case of valve stem coated by nc-WC/a-C:H mating with a guide made of cast iron [7]. Values obtained for the case of nitrided valve stem mating with its guide made of cast iron, are in the range (0.12-0.22) and are similar to those obtained for the case of the mentioned valve coated by nc-WC/a-C:H [7].

During each test the sound level have been of 94 dBA, at this of environment equal 40 dBA.

The course of friction force  $T_R$  and normal reaction  $R$  against time  $t$  obtained during simulation for the case of non-coated valve stem has been presented in the Fig. 10. Basing on such course it has been obtained values of the friction coefficient  $\mu$ .



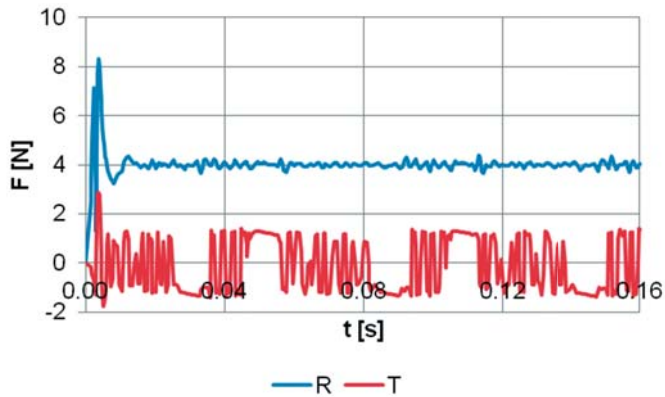

**Fig. 10. Values of friction force  $T$  and of normal force  $R$  against time  $t$ , obtained during simulations; loading frequency  $f=16$  Hz, valve stroke  $h_{max}=5$  mm**

The courses of the friction coefficient  $\mu$  against sliding velocity  $v$ , obtained during simulation have been shown in the Fig. 11. With increasing of valve stroke it has been obtained higher values of mixed friction coefficient  $\mu$ .

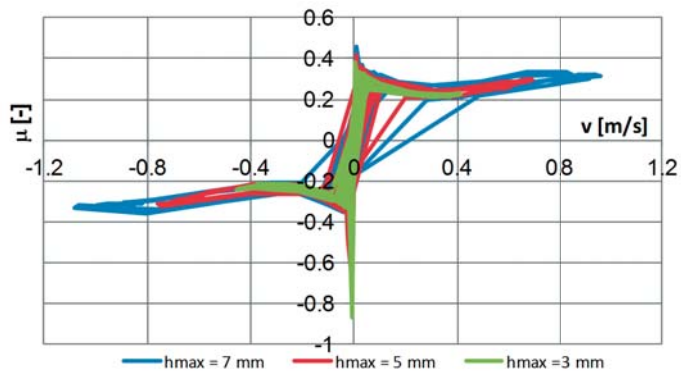

**Fig. 11. Values of friction coefficient  $\mu$  against sliding velocity  $v$ ; loading frequency  $f=16$  Hz, valve stroke,  $h_{max}=7$  mm,  $h_{max}=5$  mm and  $h_{max}=3$  mm**

The courses of the friction coefficient  $\mu$  against sliding velocity  $v$ , obtained during simulation, for the cases of non-coated, nitrided and chromed valve stem, have been shown in the Fig. 12.

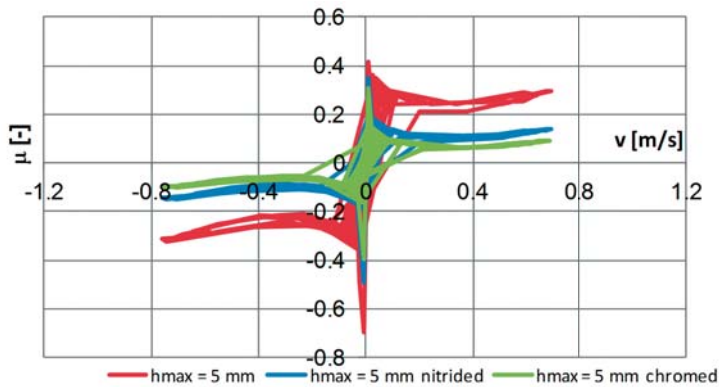

**Fig. 12. Values of friction coefficient  $\mu$  against sliding velocity  $v$ ; loading frequency  $f = 16$  Hz, valve stroke  $h_{max} = 5$  mm, without protective layer, nitrided and chromed**

Such courses have quite large width of hysteresis, which is a characteristic property for courses of the close to dry friction coefficient as the function of sliding velocity. Obtained values of mixed friction coefficient are in good agreement with measured values of dry friction coefficient. The highest values have been for non-coated valve stem and the lowest for the chromed one.

## 5. Conclusions

1. The friction coefficient in the contact zone between the valve stem made of TiAl alloy and its guide made of cast iron decreases with the increase of loading frequency and increases with increase of valve stroke.
2. The nitriding or chroming the stem of valve made of TiAl alloy can decrease the friction coefficient by up to 25%, when mating with the guide made of cast iron.
3. When modeling the mixed friction between valve stem and its guide, obtained courses of the friction coefficient against sliding velocity have quite large width of hysteresis, which is a characteristic property for situation when only dry friction occurs. It can point that for the conditions used in the model it has occurred only small share of fluid friction in the mixed friction.

## References

- [1] ZBIERSKI K., SICZEK K.: *Calculation and Verification of Forces Driving Outlet Valves in Magneto-electrical Valve Timing of Combustion Engine*. Journal of KONES, Vol. 13, No 3, s. 455-462.
- [2] THEOBALD M., LEQUESNS B., HENRY R.: *Control of Engine Load via Electromagnetic Valve Actuators*. SAE, 1994, nr 940816.
- [3] SUN Z., CLEARY D.: *Dynamics and Control of an Electro-Hydraulic Fully Flexible Valve Actuation System*. Proceedings of American Control Conference, Denver, Colorado, June 2003.
- [4] MA J., SCHOCK H., CARLSON U., HOGLUND A., HEDMAN M.: *Analysis and Modeling of an Electronically Controlled Pneumatic Hydraulic Valve for Automotive Engine*. SAE 2006-01-0042.
- [5] <http://www.precisionenginetech.com/tech-explained/2009/06/02/valve-materials-and-designs-part-1/>.
- [6] Yamagata H.: *The science and technology of materials in automotive engines*. Cambridge, England, Woodhead Publishing Ltd, 2005.
- [7] SICZEK K.: *The Researches on the Friction Properties of nc-WC/a-C Coating on the Lightweight Valve Stem*. Journal of KONES, Vol. 19, No 2, s. 493-500.
- [8] SICZEK K.: *Researches and modeling of tribological phenomena occurring in the seat insert - lightweight valve - guide system for valvetrains of internal combustion engines*. Lodz, Lodz University of Technology, 2012.