



STUDY OF SUPER/TURBOCHARGER SYSTEM FOR HELICOPTER DIESEL ENGINE

Andriy PROKHORENKO¹, Oleksandr VRUBLEVSKYI²,
Oleksandr GRYSYUK¹, Anatolii KUZMENKO¹, Sergii KRAVCHENKO³

¹ Kharkiv National Automobile and Highway University, Kharkiv, Ukraine, ap.kharkiv@ukr.net,
dthkhd@ukr.net, kuzmatolja@gmail.com

² University of Warmia and Mazury in Olsztyn, Poland, aleksander.wroblewski@uwm.edu.pl

³ National Technical University Kharkiv Polytechnic Institute, Kharkiv, Ukraine,
Serhii.Kravchenko@khp.edu.ua

Abstract

The article demonstrates a rational scheme of the supercharging system in a helicopter diesel engine with a power of 100 kW, regardless of the flight altitude, and proposes a method for assessing the power losses for a diesel engine depending on the flight altitude using a mathematical model. There are three variants of an engine supercharger scheme with a single-stage turbocharger, a two-stage one with parallel or sequential compressor drive and a turbo-blower. As a result of the computational analysis according to the original method, it was shown that from the point of view of the least energy consumption two-stage scheme with a compressor and a sequential drive is the most rational. To reduce energy losses in the drive with two-stage supercharging, a concept for controlling the pressure system was proposed, which includes changing the rotational speed of the compressor drive and adjusting the throttles. Simulation of the engines running during the climb / descent of the helicopter showed that the proposed pressure scheme and control concept is effective. In order to improve the quality of regulation, the possibility to use an electric drive with the first stage compressor is being considered.

Keywords: helicopter diesel engine, supercharging system, compressor drive, engine power, cruising altitude

1. INTRODUCTION

After the mid - 20th century, the gas turbine engines became most widespread as aircraft power plants due to their high power- weight ratio. However, the high cost of both gas turbine engines and fuel for them, as well as the low efficiency of their use at low power, it arouses interest in applying diesel engines for small aircraft [1].

Bents at al. [2, 3] confirmed that a turbocharged gasoline engine is a suitable candidate for use in small aircraft based on comparisons with gasoline, diesel, turbojet, parallel, rocket and solar engines. In order to achieve the required flight altitude, parallel-series schemes for a multistage turbo-blower are considered. However, the result is a complex system that requires multifactorial coordination. Consequently, the definition of turbochargers, the setting of intercooler parameters and the definition of system management rules have become important issues in the design for a multistage turbocharged power plant.

In addition, in the case of using piston engines in aviation, it is important to maintain their high specific effective power at rated speed at the highest possible flight altitude (the so-called "starting altitude"). However, as you know, when the altitude is increasing, the atmospheric density is

decreasing. Thus, when it rises off the ground to an altitude about 6,000 m above mean sea level, the atmospheric density is halved. Such a significant atmospheric density reduction at altitude (h) has a great impact on the efficient engine running, its reliability and resources [4]. This is due to the fact that during the ascent of an aircraft with internal combustion engine (ICE), the air mass entering its cylinders decreases. As a result, there is a low effective power descent [5]. In addition, there may be a problem with starting the engine when it is stopped in flight.

There are two main ways to solve this problem [6].

The first way is to "increase size" of the ICE. In this case, the engine is designed for excess power by increasing the cylinders displacement. Then, at $h = 0$ m, such an engine is throttled, and at the height, the fuel supply restrictions are removed and its power increases. An obvious limitation of a method is an unjustified increase for a size and engine specific weight [6].

The second method is supporting the rated power, which is most often used in modern design and research practice, it is the application of high pressure, which ensures the engine critical altitude not increasing its specific weight practically

(without including the pressurization system weight structure itself).

This particular method that was used in this work to ensure the required altitude for a diesel aircraft with a HADI-100A engine (Table 1).

Modification of automobile engines for use in aircraft is now a widespread practice. A striking example is the products of Continental Motors (USA) and Austro Engine (Austria), which successfully manufacture and install engines based on the Mercedes-Benz OM640 automobile diesel engine for light aircraft [7-9].

Table 1 Main parameters of the helicopter engine

	HADI-100A
# cylinders	4
Cylinder bore x stroke, mm	88 × 82
Compression ratio	18
Engine Displacement, cc	1999
Engine maximum speed, rpm	4000
Max. in-cylinder peak pressure, MPa	17
Max. turbine inlet average temperature, K	1000
Length x Width x Height, mm	490×530×580

Moreover, in a greater or lesser degree, many modern scientific works are devoted to the modification and application of automobile diesel engines in aviation.

Shan P. et al. [10] have developed a method for modeling a two-stage turbocharged engine with compression ignition designed for multipurpose aircraft systems at medium altitudes, low speeds, at altitudes up to 10–20 km was considered. The turbocharged engine simulation method is based on component maps or algebraic equations. This method is dealt with solution of the general equations for the drive system using Newton's iterative method to obtain the interaction points of the system. As a decisive criterion, the researchers chose the requirement to maintain the rated power and conditions for the combined operation of the turbocharging and engine. The control principles were analyzed both for rated power and power decay mode.

Lot et al. [11] presented the performance of a 60 kW Rotax 912 piston engine with a three-stage turbocharging, taking into account a three-valve control strategy and concluding that the system is applicable. It is also known the Rotax 912 single-stage turbo engine, which successfully lifted the Altus 1 aircraft to an altitude of 13.3 km. In 1999, the Rotax 912 two-stage turbo engine lifted the Altus II to an altitude of 16.8 km and had been staying for 3 hours there. Rogers [12] presented the design method, component characteristics and test results for the Rotax 912, a three-stage turbocharging with 64 pressure drop across the entire installation at 26 km altitude. Three turbochargers are specially designed and contain aluminum bearing housings, vane diffusers and titanium wheels providing a four-stage compression ratio by one stage. Among other studies, an

attention should be paid to the effect of various turbochargers to the operation of a piston aircraft engine, Korakianitis & Sadoi [13].

Despite the ability of the turbocharging which can significantly improve the performance of diesel engines at altitude when it is a drop in ambient pressure, there are few guidelines in the current literature that would facilitate the selection of a pressurization architecture during the design stages. Richard [14] studied the environmental aspects of altitude diesel engines for aviation. However, in this work, it is difficult to isolate the contribution of the turbocharging system to environmental performance. Giraud [15] assessed the effect of different engine power levels to the engine architecture, but focused on the overall engine concept rather than the turbocharging system. Carlucci [16] studied several turbocharging schemes used in diesel engines, focusing on fixed-wing aircraft rather than helicopters. In addition, differences among the schemes are the number of compressors, turbines, or the existence of intercoolers and aftercoolers, without considering the possibility that the compressors could be driven entirely by a reciprocating engine or electric machine. Ericsson [17] also presented a detailed approach to modeling the pressurization process, but does not consider alternative drives or turbocharging control concepts. Vegh [18] modeled an electric turbocharged diesel engine used in a rotorcraft and estimated fuel consumption. However, the turbocharging process was not modeled and was considered only as a power consumer.

In work [19], the analysis about technical, economic and environmental indicators for various piston engines with aviation purposes was carried out. It is noted that at a flight altitude of $h = 6000$ m, the engine power drops significantly (up to 32%). This makes manufacturers to design aircraft engines with power reserves.

In works [20, 21], a feasibility study and conceptual provisions for the modification of an automobile diesel engine with a Common Rail fuel system for installation to a light helicopter are presented. Particular attention is paid to recommendations regarding the selection of a turbocharging. It is shown that the operating conditions of diesel engines for automobile and aviation purposes are differed significantly. If it is an automobile diesel engine it is necessary to ensure maximum torque at a low-end torque, then for an aviation engine it is important to have high effective power at rated speed and maintain it at the highest possible altitude. Therefore, the turbocharging system operation for an aircraft engine will also differ from the automobile one.

Similar computational studies are described in a work [22]. The authors in this article have shown that in order to increase the altitude of a two-stroke aircraft diesel engine with a power of 100 kW, it is necessary to supplement its autonomous

pressurization system with an Eaton TVS R410 drive compressor with a power of 14 kW.

The aim of this article is to select and substantiate a rational scheme of an aviation diesel engine turbocharging system to ensure its altitude up to 5000 m above the mean sea level in terms of the least loss of effective engine power. It should be noted that this work is far from being limiting and represents the first step in modifying an automobile diesel engine for use in small aircraft.

Thus, it can be concluded when designing or modifying an aircraft diesel engine, the following methodological sequence should be followed:

1. To evaluate the required, from the point of providing a given effective power, parameters of the air charge at the inlet based on the fact that the environmental parameters are changing significantly with altitude.

2. To select the required and implemented supercharging scheme, including the parameters and the number of compression stages, the type of regulation, the required cooling units, etc.

3. To perform a preliminary calculation for such a system.

2. STARTING POSITIONS AND BACKGROUNDS FOR ANALYTICAL CALCULATIONS

This study was based on the conditional vertical distribution of the thermodynamic air parameters in the Earth's atmosphere known as the International Standard Atmosphere [23, 24]. Therefore, we will assume that with the flight altitude, the environmental parameters – pressure p , temperature T and air density ρ – are changing according to the law shown in the graphs in Fig. 1.

The study described below was carried out by this sequence. As a result of working out the presented methodological sequence, new original results had been obtained, containing a new concept to ensure the required power for an aircraft engine, using the supercharging as a decisive parameter and the maximum combustion pressure and energy costs for air compression.

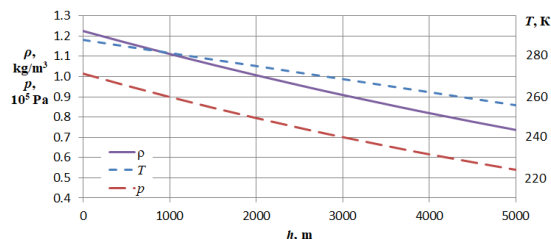

Fig. 1. Vertical distribution of pressure, temperature and air density in the atmosphere [22]

Tests results with the prototype engine HADI-100A [25] under normal atmospheric conditions (altitude above the sea level $h = 0$ m) showed: engine effective power $N_e = 103$ kW with excess air ratio $\lambda(0) = 1.65$ and pressurization $p_s = 273300$ Pa.

In this case the air-quantity flow was $V_{air}(0) = 0.129$ m³/s.

Let us analyze the influence of environmental parameters (flying height h) to the engine criteria and its pressurization system. In this case, we will proceed from the fact that at all flying heights of the aircraft it is possible to provide a working process in the engine cylinders equivalent to the working process on the ground (at $h = 0$ m). Then the same enthalpy of the exhaust gases will be supplied to the turbine of the turbo compressor at all altitudes, i.e. we can say that the power of the turbo compressor turbine does not depend on the height h .

It follows that the power of the compressor will also be constant and equal to the power N_c that the compressor has at $h = 0$ m.

$$N_c(0) = \frac{l_k(0)}{\eta_k} V_{air}(0) \cdot \rho(0), \quad (1)$$

where l_k is the specific work of polytropic air compression in the compressor, J/kg, η_k is the adiabatic efficiency of the compressor, V_{air} is the air-flow rate through the compressor, m³, ρ is the air density, kg/m³.

It is known that the specific work of polytropic compression in gas compressors under normal conditions is determined as follows [26, 27]:

$$l_k(0) = \frac{R \cdot T(0)}{n-1} \cdot \left[\left(\frac{p_s + \Delta p_{cool}}{p(0) - \Delta p_{fil}} \right)^{\frac{n-1}{n}} - 1 \right]. \quad (2)$$

Henceforward, when performing calculations, constant values are taken: aerodynamic resistance of the air cooler $\Delta p_{cool} = 8000$ Pa; aerodynamic resistance of the air filter $\Delta p_{fil} = 4000$ Pa; compression polytropic index in the compressor $n = 1.56$; gas constant for air $R = 287$ kJ/(kg K).

The calculation made by this way shows that the compressor output on the ground ($h = 0$ m) required to ensure the declared engine parameters will be $N_c(0) = 15.5$ kW.

Then, on the basis of the constancy of the compressor power-altitude $N_c = N_c(0) - const$ and taking as an assumption the independence of the boost pressure altitude at the engine inlet $p_s - const$, it is possible to determine the air-flow rate through the turbo compressor, which will occur when the aircraft is lifted to different altitude.

$$V_{air}(h) = \frac{\eta_k \cdot N_c}{\rho(h) \cdot R \cdot T(h)} \cdot \frac{n-1}{\left(\frac{p_s + \Delta p_{cool}}{p(h) - \Delta p_{fil}} \right)^{\frac{n-1}{n}} - 1}. \quad (3)$$

Here $p(h)$ and $T(h)$ is the pressure - free-air temperature on the altitude (Fig. 1). The predictions are made by formula (3) are shown in Fig. 2.

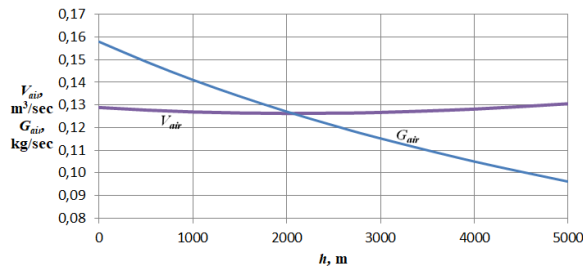

Fig. 2. Dependence of the air-flow rate through the flow through the compressor on the altitude above the mean sea level

Fig. 2 shows that the air-flow rate through the turbocharging slightly depends on the altitude (at least up to $h = 5000$ m). The mass flow rate will drop significantly due to a decrease air density altitude, since $G_{air}(h) = V_{air}(h) \cdot \rho(h)$. Here $\rho(h)$ is the dependence of the air density on the altitude density (Fig. 1).

Thus, in the case of the value conservation with the cyclic fuel supply, the excess air ratio will change according to the dependence:

$$\lambda(h) = \frac{V_{air}(h) \cdot \rho(h)}{V_{air}(0) \cdot \rho(0)} \lambda(0), \quad (4)$$

where $\lambda(0)$ is the excess air ratio under the conditions $h = 0$ m.

Based on these prerequisites, let us analyze various schemes of engine pressurization: with one free turbo compressor; parallel drive compressor and turbo compressor; sequential drive compressor and turbo compressor.

3. RESEARCH PROCEDURE

3.1. Scheme with one free turbo compressor (basic version)

The diagram of the "basic" turbocharging system for diesel engine with one turbocharging is shown in Fig. 3.

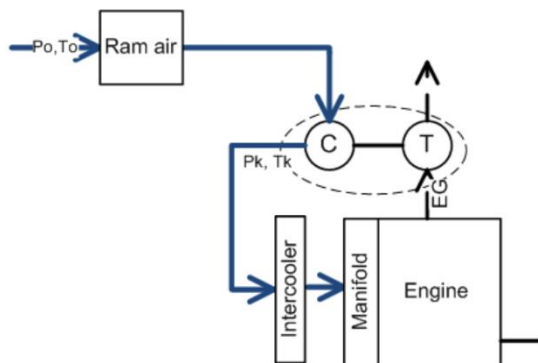

Fig. 3. Scheme of a diesel engine turbocharging (basic version)

As was already mentioned, the main factor determining the diesel operation at altitude is the low air density, which leads to a decrease a mass flow ratio through the engine and, as a consequence, to an air-fuel coefficient λ loss during fuel combustion in the cylinder. To maintain

constant α , it is necessary to reduce the value of the cyclic fuel supply, which, given the approximate constancy of the effective engine efficiency, leads to a power loss. The absolute value of the engine power loss when the mass air flow rate changes and the condition is maintained $\lambda(h) - const$ can be estimated as follows:

$$N_{e1}(h) = \left(1 - \frac{V_{air}(h) \cdot \rho(h)}{V_{air}(0) \cdot \rho(0)}\right) N_e(0). \quad (5)$$

Further, when considering systems with a driven compressor, it should be taken into account that the control parameter will be the fraction of the effective engine power consumption (lost) to drive it.

3.2. Parallel drive compressor scheme

A diagram with a turbocharger and a parallel drive compressor is shown in Fig. 4. With the practical implementation of this scheme, the compressor drive can be not only mechanical, but also electric, hydraulic or pneumatic. However, in any case, the power required for this will be taken as mechanical energy directly from the engine crankshaft.

With such a parallel supercharging scheme, in each of the compressors, only a part of the total air charge is compressed and supplied to the cylinder and to the intake manifold. This fact determines the smaller required dimensions of the compressor wheels, that is, such compressors will be less inertial.

Let us change formula (2) to obtain the dependence of the polytropic compression specific work in the compressor on the altitude like this:

$$l_k(h) = \frac{R \cdot T(h)}{n-1} \cdot \left[\left(\frac{p_s + \Delta p_{cool}}{p(h) - \Delta p_{fil}} \right)^{\frac{n-1}{n}} - 1 \right]. \quad (6)$$

Then the required power of the drive compressor is determined by the missing mass air supply by the turbocharger in comparison with normal conditions

$$\Delta N_{e2}(h) = \frac{l_k(h)}{\eta_k} \times (V_{air}(0) \cdot \rho(0) - V_{air}(h) \cdot \rho(h)), \quad (7)$$

and it will be equal to the consumption (loss) of engine power to drive the compressor.

The scheme limitations in Fig. 4 is the complexity to implement the identical compression cycles for compressors C and C2. The wave phenomena accompanying the compression can lead to a decrease the commutative effect by the given supercharging system. This can lead to a decrease the air pressure supplied to the engine manifold below the p_k values. To overcome this problem, a complex control system and optimal geometry of the intake system are required, which neutralizes the potential advantages of the scheme in Fig. 4.

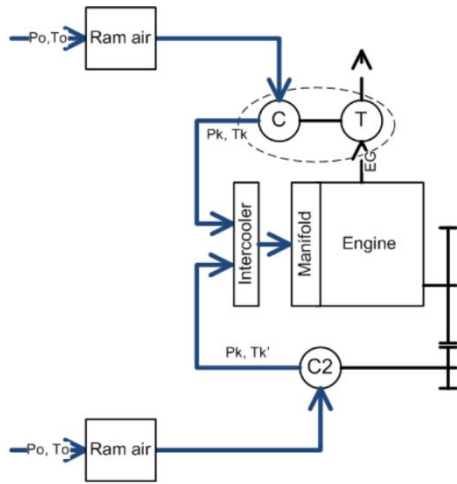

Fig. 4. Diagram of diesel engine supercharger with parallel connection of compressors C, C2

3.3. Sequential drive compressor scheme

A similar scheme with the use of a turbocharger and a sequential drive compressor is shown in Fig. 5.

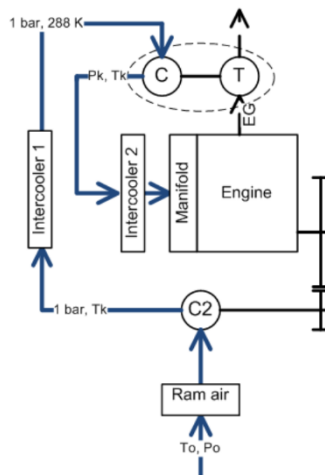

Fig. 5. Diagram of diesel engine supercharger with series connection of compressors

Such schemes are usually used when it is necessary to increase the total pressure ratio [28-30], they require precise the blade machines operation matching with each other, as well as with the piston engine flow performance.

It is assumed that the first is the drive compressor in the air flow, which, together with its outlet intercooler, supplies air to the turbocharger with the parameters of normal conditions $p(0)$ and $T(0)$. Then its specific work of compression will have the value

$$l'_k(h) = \frac{R \cdot T(h)}{n-1} \cdot \left[\left(\frac{p_0}{p(h) - \Delta p_{fit}} \right)^{\frac{n-1}{n}} - 1 \right]. \quad (8)$$

And the required engine power to drive the compressor will be equal to:

$$\Delta N_{e3}(h) = \frac{l'_k(h)}{\eta_k} V_{air}(0) \cdot \rho(0). \quad (9)$$

4. A SUPERCHARGED HELICOPTER ENGINE MODELING

4.1. Engine model

To simulate the airplane engine operation under changing conditions accompanying the flight of a small aircraft, an original engine model (Fig. 6), created in the AmesIM 2019[®] software environment, is used.

In the model, depending on the selected parameters, two main pressurization schemes are implemented: one-stage compression in the turbo compressor according to the scheme in Fig. 3 and two-stage compression according to the scheme in Fig. 5. For the first compression stage according to the scheme in Fig. 5 uses an Eaton M65 5th Generation compressor is used [https://www.eaton.com/us/en-us/products/engine-solutions/superchargers.html]. Validation of the engine model, which consists of refining the empirical dependences of the combustion and heat transfer models, was carried out using a special algorithm Calibration of the combustion chamber on the AmesIM 2019[®] software. The HADI-100A engine tests results on a motor stand were used as the initial data for validation (Fig. 7). The effectiveness of validation is confirmed by the identity of the calculated and empirical pressure changes in the engine cylinder (Fig. 8) at the selected load.

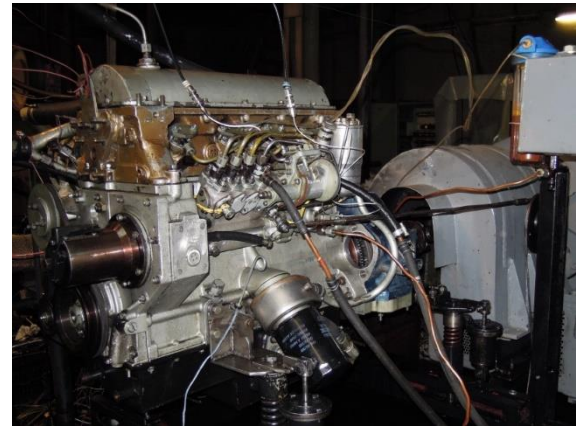

Fig. 7. Diesel engine on the test bench

The engine model provides the ability to flexibly change the gear ratio of the compressor drive at the first stage, as well as with the help of the appropriate throttle, the complete expulsion of the drive compressor from the circuit. For flight simulation, the model has the ability to set the characteristics of the pressure and temperature changes at the inlet to the engine. The used simulation tools make it possible to solve the set problem of stabilizing the engine power at a given level according to the decisive parameter "boost pressure" taking into account the functional limitations - the maximum combustion pressure and minimization of energy consumption for providing the engine with air.

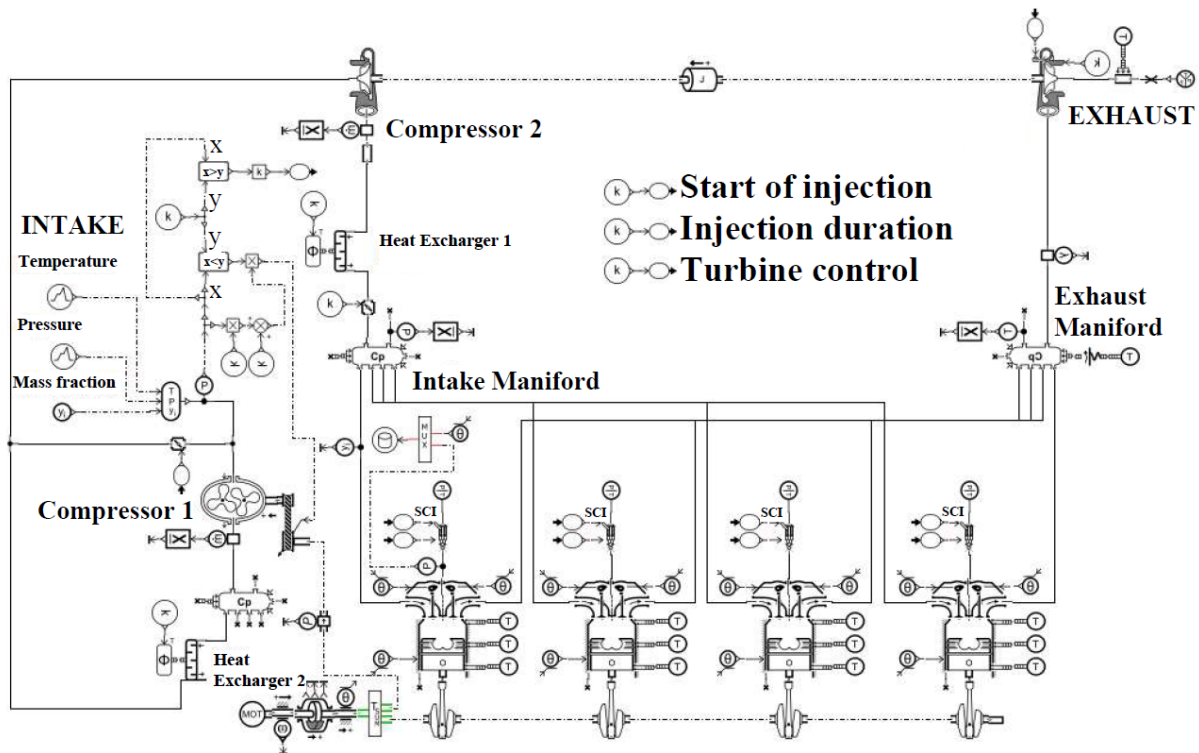

Fig. 6. Engine model in the AmeSIM 2019® program

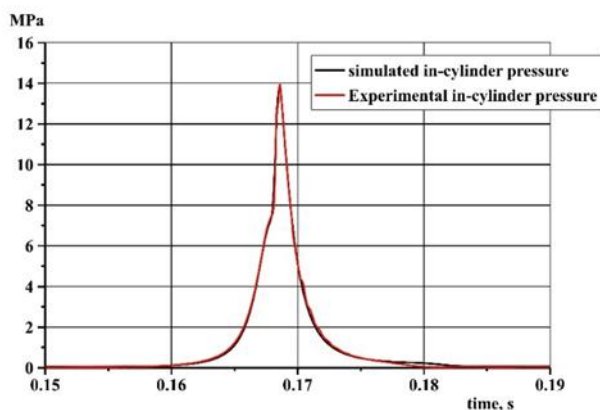

Fig. 8 Comparison of the calculated and experimental pressure in the engine cylinder at a load of 2800 rpm

4.2. Simulation results

The change in engine power depending on the conditions of filling the cylinders, changing with height (Fig. 9) they show the possibilities of the methods described above to increase the pressure at the inlet to the engine intake manifold. The most problematic is to provide the target power with one compression stage using a turbo compressor (curve N1_A). In this case, even above $h = 500$ m, the engine power level does not meet the requirements. When using two-stage compression according to the scheme in Fig. 5 power (curve N3_A) is provided up to $h = 3000$ m. Then the power is reduced with an intensity of 10 kW for $h = 500$ m. The power consumption for the drive at the first

stage of the compressor (Fig. 10) reduces the engine power by an average of 1.5 kW.

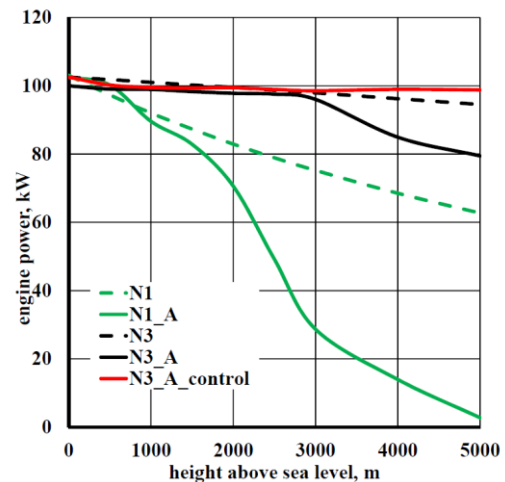

Fig. 9. Dependence of engine power on the adopted supercharger scheme and altitude

The best power characteristic (N3_control curve) is obtained with a two-stage supercharged engine with a drive compressor ratio control. In the proposed version, depending on the ambient pressure, the gear ratio of the transmission changes in direct proportion, and the moment of turning on the compressor is also determined. For example, taking account of the fact that the turbocharger provides independently the engine with air up to 1000 m, the control pressure is taken as 0.09 MPa (Fig. 10). The result of applying this control strategy is a decrease in energy consumption for the first stage compressor operation in the range from 0

to 3000 m. A further increase in energy consumption is associated with the need to increase the gear ratio of the compressor to maintain the engine power of approx. 100 kW. The data in Fig. 10 show that it is possible to use an electric drive for drive compressor at the first stage, which will provide optimal elastic boost control.

To check the validity of the selected supercharger scheme and the control concept of the drive compressor, a simulation of the engine operation in flight conditions was carried out (Fig. 11). The flight mode includes the following stages: engine operation at sea level at a pressure of 0.10133 MPa and a temperature of 288.2 K, then an aircraft ascends to 3000 m for 8 minutes, which corresponds to a climbing speed of 6.25 m/s. Further, a short segment of constant altitude of 3000 m, followed by a descent at a speed of 7.15 m/s. The data in Fig. 11 show that the engine provides power in the range of 105 - 100 kW for the entire duration of the flight.

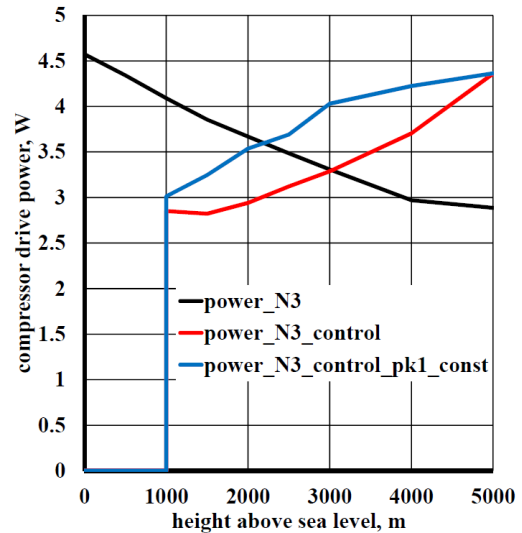

Fig. 10. Power consumed to air compression at the first stage of the compressor C2 (without losses in the compressor drive)

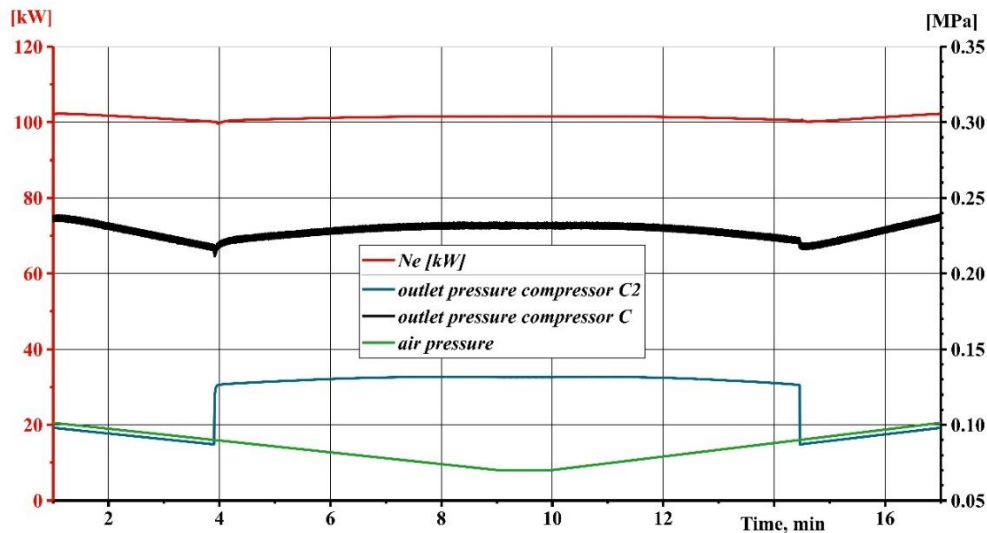

Fig. 11 Change in engine power with variable two-stage supercharging in flight conditions

The compressor operation at the second stage with the supercharger system throughout the entire duration of the flight is characterized by maximum efficiency, which is confirmed by the position of the working points in space, the engine pressure ratio - air flow rate (Fig. 12, 13). The cell array with the maximum pressure ratio reflects the transient associated with the drive compressor on/off. At the same time, the smallest values of the pressure ratio increase correspond to the engine operation at 0 m above sea level and are associated with the preparation of the aircraft for flight (starting and warming up the engine).

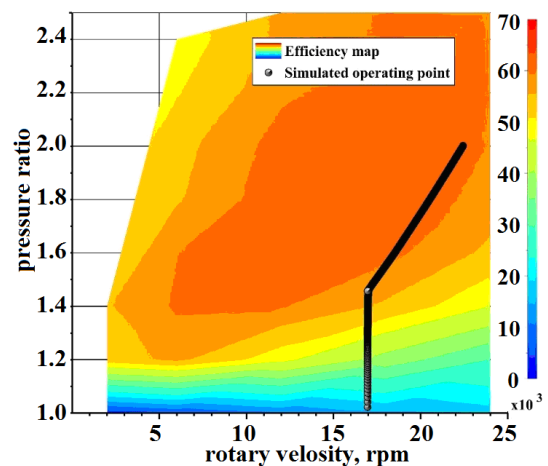

Fig. 12 Compressor C2 map

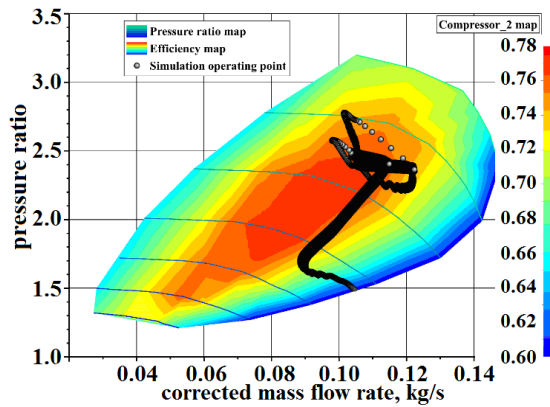

Fig. 13 Compressor C map

5. TEST RESULTS ANALYSIS

The calculation for each of the considered schemes with supercharger system was carried out according to the above formulas (3) - (9). The results of these calculations are summarized in table 2 and partially illustrated in Fig. 9. The absolute values of the effective power are calculated as $N_e(h) = 103 - \Delta N_e(h)$.

As can be seen in the table, in the case of using the basic turbocharging system at an altitude of $h > 1500$ m, the normal operating process of a diesel engine cannot be realized, since in this case the excess air ratio falls below the critical value for a diesel engine $\lambda < 1.4$. In schemes with a driven compressor, the quality of the air-fuel mixture will not change with altitude.

Table 2 Calculation results

h , m	T , K	p , Pa	ρ , kg/m ³	V_{air} , m ³ /s	λ
0	288.2	101330	1.225	0.129	1.65
500	284.9	95464	1.167	0.128	1.56
1000	281.7	89877	1.112	0.127	1.47
1500	278.4	84559	1.058	0.126	1.40
2000	275.2	79499	1.007	0.126	1.33
2500	271.9	74690	0.957	0.126	1.26
3000	268.7	70123	0.909	0.127	1.20
4000	262.2	61661	0.819	0.128	1.10
5000	255.7	54052	0.737	0.131	1.00

In Table 2 you can see the dependence of the free effective engine power from flying height when using the considered supercharger systems. Analysis of the data given in this graph and in the table shows that in the case of one free turbo compressor, the effective engine power decreases by about 6 – 11 kW per 1000 m as the flight altitude increases, on conditions to keep $\lambda(h) = const$.

In schemes with a drive compressor, the power losses (consumptions) for their drive are relatively insignificant - within 1 – 2 kW per 1000 m of

altitude, and, in principle, they can be compensated for by increasing the cyclic fuel supply without losing the quality of the working process (i.e. within the acceptable value of the excess air ratio, at least up to an altitude of 5000 m).

It can also be seen from the results obtained that a scheme with a series connection of a drive compressor is more profitable from the point of view of lower power consumption for its drive: at an altitude of 5000 m, 1.4 kW less than in a scheme with a parallel drive compressor; is the maximum value of 8.5 kW.

In conclusion, it should be said that, according to the authors, the most rational thing is the use of an electrically driven air compressor. In this case, the unit gains control flexibility to select the optimal operating mode and the ability to use energy sources alternative to the drive electric generator (both for its complete replacement and partial). These can be solar panels, accumulators, thermoelectric generators, etc.

At the same time, the obtained maximum value of power consumption of 8.5 kW is precisely the determining factor when choosing an electric generator for the engine and an electric motor for driving this unit.

6. CONCLUSIONS

When creating a diesel engine for use in small aircraft, the problem arises to reduce its effective power, caused by a significant decrease in the density of atmospheric air as the flight altitude increases. To solve this problem, it is necessary to use such a supercharger system that will compensate for the change in the mass air flow through the engine with the lowest energy costs.

In particular, the analysis of three variants for the engine supercharger system scheme performed in the work: with one turbocharger, parallel drive compressor and supercharger, sequential drive compressor and turbo compressor, showed:

1. In the case of using one turbocharger, the working process of a diesel engine at an altitude of more than 500 m cannot be realized without a significant loss of power, due to a drop in the effective filling of the cylinders with air.

2. When using a two-stage supercharging, a given constant effective power is provided up to 3000 m, and then its power occurs with an intensity of 10 kW per 500 meters. At the same time, the power consumption for the drive at the first stage of the compressor reduces the engine power by an average of 1.5 kW.

3. The best power characteristic is ensured by the use of a two-stage boosting scheme and by adjusting the gear ratio of the air compressor drive. The result of applying this control strategy is to reduce the energy consumption for the operation at the first stage of the compressor in the range from 0 to 3000 m.

4. To ensure flexibility of control, automatic selection of the most rational mode of the unit operation and the possibility of using alternative energy sources, it is proposed to use an electric drive with an air compressor.

Prospects for further work in this direction are:

1. Selection and substantiation of the most efficient energy sources for driving an electric air compressor at the first stage.

2. Creation of rational algorithms for the electronic control unit with the regulatory bodies of the supercharger system: the gear ratio of the air compressor drive, bypass channels in the intake and exhaust system, changing the geometry of the turbine nozzle, etc. to ensure the most efficient operating modes of the entire power plant.

REFERENCES

- Lohinov VV, Ukrayinets' YEA, Kravchenko IF, Elansky AV, Analiz l'otno-tekhnichnykh kharakterystyk i ekonomichnykh pokaznykiv lehkoho rehional'noho litaka z aviatsynym dyzel'nym i hazoturbinnym dvyhunamy. Aviatyyno-kosmichna tekhnika i tekhnolohiya. – 2014; 10:35-48.
- Bents DJ, Mockler T, Maldonado J. Propulsion selection for 85kft remotely piloted atmospheric science aircraft. NASA Lewis Research Center, Cleveland, OH, Report No. TM-107302. 1996.
- Bents, DJ, Mockler T, Maldonado J, Harp James L, King JF, Schmitz PC. Propulsion system for very high altitude subsonic unmanned aircraft. NASA Lewis Research Center, Cleveland, OH Report No. TM 1998-206636. 1998.
- Roueini, Ali, Mirzabozorg Mohsen, Kheradmand Saeid. Developing a mathematical modelling code for keeping the power of multi turbocharged engines at flight altitudes. J. Aerosp. Technol. Manag. 2020;12:1220. <https://doi.org/10.5028/jatm.v12.1085>.
- Piancastelli LL, Frizziero S, Pica, Donnici G. High altitude operations with piston engines powerplant design optimization part iv: radiators optimum design. 2016.
- Diesel, Spark-Ignition, and Turboprop Engines for Long-Duration. Unmanned Air Flights. Daniele Cirigliano, Aaron M, Frisch, Feng Liu, William A. Sirignano. University of California, Irvine, California 92697. <https://doi.org/10.2514/1.B36547>
- Continental CD-135 Jet-A Engine [Электронный ресурс]. – Режим доступа: <http://www.continentalmotors.aero/diesel/engines/cd135.aspx – 15.04.2020>.
- CD-135 – kerosene piston engine with 135 hp <http://www.continentaldiesel.com/typo3/index.php?id=101&L=1>.
- AE300/AE330 Key Benefits: https://www.austroengine.at/uploads/pdf/mod_products9/AE330FactSheet.pdf
- Shan P, Zhou Y, Zhu D. Mathematical model of two-stage turbocharging gasoline engine propeller propulsion system and analysis of its flying characteristic. Journal of Engineering for Gas Turbines and Power. 2014;137(5):051201. <https://doi.org/10.1115/1.4028664>
- Loth JL, Morris GJ, Metlapalli PB. Staged turbocharging for high altitude IC engines. AIAA Paper No. 1997-3970.
- Rodgers C. Turbocharging a high altitude UAV C.I. Engine. AIAA Paper No. 2001-3970.
- Korakianitis T, Sadoi T. Turbocharger-design effects on gasoline-engine performance. ASME J. Eng. Gas Turbines Power. 2005;127(3):525-530.
- Richard S. Potential of high power density Diesel engines for green rotorcrafts propulsion. 49th AIAA/ASME/SAE/ASEE Joint Propulsion Conference, 2013:3670.
- Giraud M. Power level influence on architecture of small helicopter turboshaft engines. ASME 1986 International Gas Turbine Conference and Exhibit, American Society of Mechanical Engineers, 1986.
- Carlucci AP, Ficarella A, Laforgia D, Renna A. Supercharging system behavior for high altitude operation of an aircraft 2-stroke Diesel engine. Energy Conversion and Management. 2015; 101: 470-480.
- Eriksson L. Modeling and control of turbocharged SI and DI engines. Oil & Gas Science and Technology-Revue de l'IFP. 2007; 62(4): 523-538.
- Vegh JM, Alonso JJ, Sinsay JD. Modeling of diesel and diesel-electric hybrid propulsion systems for conceptual design of rotorcraft. San Francisco, CA, 2016.
- Wendeker M, Siadkowska K, Magryta P, Czyz Z, Skiba K. Optimal Diesel engine technology analysis matching the platform of the helicopter. Wendeker . World Academy of Science, Engineering and Technology International Journal of Aerospace and Mechanical Engineering. 2014;8(5):851-855.
- Piancastelli L, Frizziero L, Donnici G. Turbomatching of small aircraft diesel common rail engines derived from the automotive field. ARPN Journal of Engineering and Applied Sciences. 2015;10(1): 172-178.
- Piancastelli L, Frizziero L. The installation of a common rail diesel engine on a light helicopter of the eurocopter EC120 class. Ingeniería e Investigación. 2016; 36(1): 6-13.
- Karpiński P, Pietrykowski K, Grabowski Ł. Turbocharging the aircraft two-stroke diesel engine. Combustion Engines. 2019; 17(3): 112-116. <https://doi.org/10.19206/CE-2019-319>.
- Vaughan WW, Johnson DL. Aerospace vehicle development applications of atmospheric thermodynamic inputs. J Aerosp Technol Manag. 2013;6(1):7-17. <https://doi.org/10.5028/jatm.v6i1.279>
- Johnson, DL, Vaughan WW. How Atmospheric thermodynamic parameters and model atmospheres have been used to help engineering in aerospace launch vehicle design & development. 50th AIAA 2012 Aerospace Sciences Meeting, Nashville, TN. 2012.
- Grytsyuk O, Vrublevskiy O. Investigation of diesel engine in the road test. Diagnostyka. 2018;19(2): 89-94. <https://doi.org/10.29354/diag/90279>.
- Fundamentals of engineering thermodynamics, second edition. Michael J. Moran, Howard N. Shapiro, Chichester, John Wiley & Sons 1993.
- Zinner A, Winkler G. Supercharging of Internal Combustion Engines. Berlin, Springer Berlin Heidelberg. 1981.
- Samoilenko D, Marchenko A, Prokhorenko A. An alternative method of variable geometry turbine adjustment: A comparative evaluation of alternative

method and nozzle ring adjustment. Paper presented at the transport means. Proceedings of the International Conference, 2016: 517–521.

29. Xu Bin, Yu Jing-Yue, Wei Lin. Research of two-stage turbo-charging system of aero-engine at high altitude. *Vehicle & Power Technology*. (2009);02:41.
30. Ding Xianfei, Xu Bin. Study on regulating law of two-stage turbo charger system of piston aircraft engine. The 2nd International Symposium on Aircraft Airworthiness (ISAA 2011). *Procedia Engineering* 17 (2011);581:–586
<https://doi.org/10.1016/j.proeng.2011.10.072>

Received 2021-04-12

Accepted 2021-07-26

Available online 2021-08-13



Andriy PROKHORENKO-

Dr. tech. Sciences, Professor, Head of the Department of Internal Combustion Engines, Kharkiv National Automobile and Highway University, Kharkiv, Ukraine



Oleksandr VRUBLEVSKYI,

DSc., DEng. – professor in the Faculty of Technical Sciences, the University of Warmia and Mazury in Olsztyn



Oleksandr GRYTSYUK, DSc.,

DEng. – professor in the Faculty of Automotive, Kharkiv National Automobile and Highway University, Kharkiv, Ukraine



Anatolii KUZMENKO- PhD,

Associate Professor, Associate Professor of the Department of Internal Combustion Engines, Kharkiv National Automobile and Highway University, Kharkiv, Ukraine



Sergii KRAVCHENKO- PhD,

Associate Professor of the Department of Internal Combustion Engines, National Technical University "Kharkiv Polytechnic Institute", Kharkiv, Ukraine