

Branislav Dobrucký, Slavomír Kaščák, Michal Praženica, Peter Drgoňa

# Modeling and simulation of charging and braking regimes of AC/AC powertrain of HEV vehicle

JEL: L94 DOI: 10.24136/atest.2018.491  
 Data zgłoszenia: 19.11.2018 Data akceptacji: 15.12.2018

The paper deals with modeling and simulation of chosen operational modes of HEV vehicle with direct AC/AC transfer and five-phase IM traction motors. Such configuration yields smaller voltage drops compared with the serial AC/DC/AC converter and five-phase machines offer some inherent advantages over their three-phase counterparts. The advantages include reduced electromagnetic torque pulsation and also noise characteristics of the five-phase drives are better when compared with the three-phase ones. Charging and braking regimes were chosen as possible operational modes for modeling and analyses. The result of the simulation, carried out with using of Matlab/Simulink are given in the paper.

## Wstęp

A major motivation to develop hybrid electric vehicles (HEV) is the possibility of combining the advantages of pure electric vehicles and conventional combustion-based vehicles to enhance fuel economy [1-3]. HEV combine conventional propulsion based on ICE engine with petroleum fuel and electric propulsion with a motor powered by accu-batteries or batteries of supercapacitors. Configuration with motor-wheels allows flexibility of the car; it removes the central drive motor and associated transmission parts of the propulsion system of the vehicle. The main advantage of the electric motor in the wheel is adjustable traction and braking torque individually and with high precision without ingestion gearbox, drive shaft, differential gear and other complex and heavy parts of power transmission [2], [4], [9]. The function of the electronic differential is possible to provide even with two motors supplied from one converter [5-6]. Regarding noise of the motors, multi-phase ones are better than three-phases [5], [13].

Depending on the vehicle concept, different electric machines (also known as a motor/generator) may be used. Today's electric traction motors in hybrid or electric vehicles are mainly permanent magnet synchronous machines (PMSM) and induction, asynchronous machines (IM). The first one benefits from a primary efficiency and good controllability, which make them highly candidates for applications in (plug-in) HEVs or battery electric vehicles [2], where-

as the latter will often be used if cost and robust operation are in focus in the vehicle application. A major drawback of IM compared with PMSM is the higher required installation space in the vehicle. There are several modes of operation of driving and braking of the hybrid electric vehicle, the single or hybrid ones [1-3], [10]. This paper deals with charging and braking regimes of ac/ac powertrain of HEV vehicle as they are:

- battery charging mode: the engine-generator charges the battery and the traction motors are not supplied,
- regenerative braking modes:
  - the engine is turned off; traction motors are operated as generators and the energy provided is used to charge the battery,
  - as above but the engine is turned on - hybrid mode: the energy of motors is used to charge the battery and braking of ICE.

Regarding configurations of an electrical part of the propulsion system, we have used powertrain with direct AC/AC system which does not comprise DC interlink and operates with direct matrix converters (MxC). A number of phases of AC interlink between generator and MxC, based on compromise has been selected as 3-phase interlink since traction motors are 5-phase ones [7], [11]. Previous AC/AC system with 4QC battery converter and one matrix converter has been replaced by one [3x5] matrix converter and one auxiliary [0x5] MxC.

## 1 Description OF direct AC/AC transfer of HEV

The scheme of direct AC/AC powertrain without 4QC battery converter is shown in Fig. 1a.

Such a configuration provides all operational modes of HEV powertrain including of electronic differential function. As mentioned the direct AC/AC converter consists of two matrix converters: [3x5] MxC is the main one for driving/braking of traction motors, and auxiliary [0x5] MxC for hybrid regimes and charging of accu-battery by ICE engine through synchronous generator SG.

Traction accu-battery AB is connected to the matrix converters directly by 2-pole breakers. HEV vehicle is steering by vehicle control system VCS using inputs DIR (direction) and POW (power). The analysis and simulation of the system are performed, so far, with

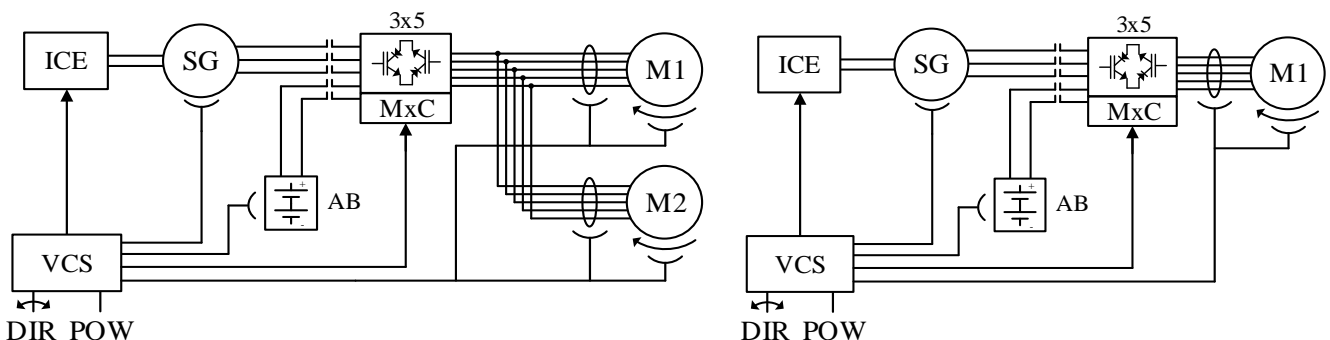
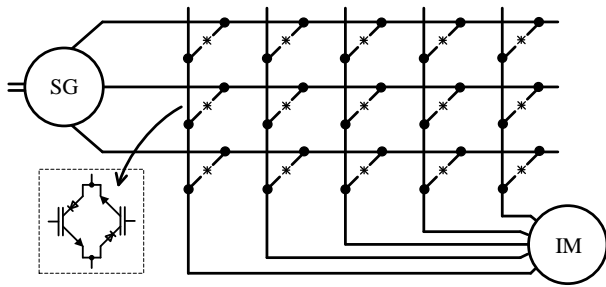

Fig. 1. Direct AC-AC propulsion system with two [3\*5] matrix converters and electronic differential with two traction motors connected in parallel Fig. 1a, and with one converter and one traction motors Fig. 1b for simulation only

one traction motor.

The basic core of AC-AC powertrain is [3x5] matrix converter, Fig. 2, equipped with bidirectional RB\_IGBT switches (see detail in Fig. 2).



**Fig. 2** Schematics of [3x5] matrix converters with bidirectional switches (in detail)

This topology can be modified by software tools to [3x0] or [5x0] MxC connections needed for chosen operational modes of AC/AC analyzed in the next text.

## 2 Charging and braking modes of operation – modeling and simulation

### 2.1 Charging mode of accu-battery powered by ICE/SG

The first part of operation modes is the battery charging mode, the engine-generator charges the battery and the traction motors are not supplied, Fig. 3.

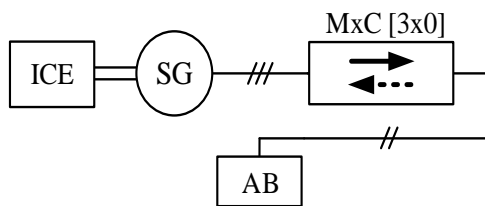
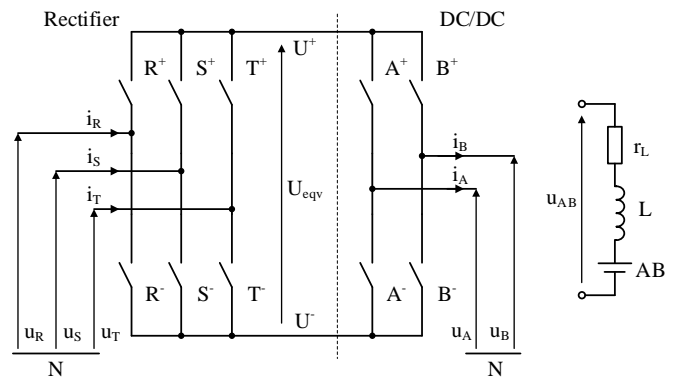

**Fig. 3** Charging of accu-battery A, or start-up of ICE using battery AB through the synchronous generator SG

The virtual model of [3x0] MxC matrix converter with fictitious DC link in indirect connection is drawn in Fig. 4. Model of DC motor with separate exciting winding [2], [11] has been used for modeling of ICE engine without turbocharger Vacuum Actuator. Model of the synchronous generator SG with permanent magnets has been used from [2], [12]. When modeling indirect [3x0] matrix converter we can write for output voltages

$$u_s = \frac{2}{3} (u_R + u_S e^{j\frac{2\pi}{3}} + u_T e^{-j\frac{2\pi}{3}}) = u_\alpha + j u_\beta \quad (1)$$

where input voltages  $u_R, u_S, u_T$  can be obtained from the model of ICE/SG system already modeled in [2], [11].



**Fig. 4** Virtual model of indirect [3x0] MxC with fictitious DC link and accu-battery circuit (in detail)

Rectified  $u_{A-B}$  the voltage then will be

$$u_{A-B} = |u_s| = \frac{1}{\sqrt{2}} (u_A - u_B e^{j\frac{\pi}{2}}) \quad (2)$$

and the current flowing to the accu-battery

$$u_{A-B} = r_L i_{AB} + L \frac{di_{AB}}{dt} + U \quad (3)$$

$$\frac{di_{AB}}{dt} = -\frac{r_L}{L} i_{AB} + \frac{u_{A-B} - U}{L}, \quad (4)$$

where  $U$  is inner an voltage of accu-battery AB.

**Simulation results** are presented in figures Fig. 5 - Fig. 7.

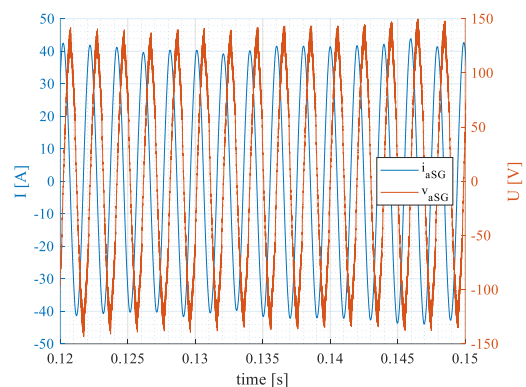

**Fig. 5** Voltage and current of synchronous generator PMSG

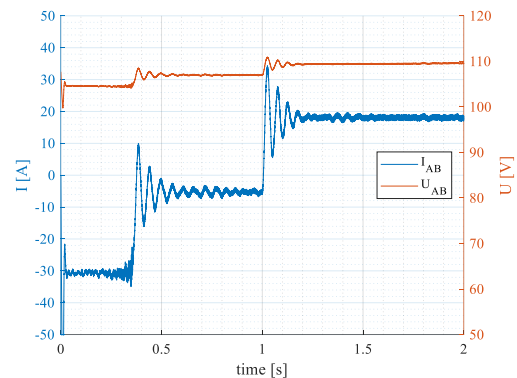

**Fig. 6** Voltage and current of accu-battery AB

The first part of the Fig. 6 represents the start-up of ICE engine through the synchronous generator SG. The second time interval is idle-state of ICE (without the load), and the third one is the charging of accu-battery.

The same situation is shown in Fig. 7 for speed, torque and reference torque of synchronous generator.

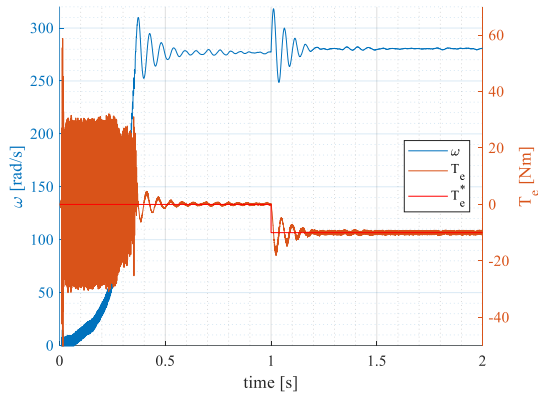

Fig. 7 Speed, torque and reference torque of synchronous generator SG during charging of accu-battery AB

Actually, as in the previous case, the first part of the figure represents the start-up of ICE engine through the synchronous generator SG. The second time interval is idle-state of ICE (without the load), and the third one is the charging of accu-battery.

2.2 Regenerative braking/charging modes of accu-battery powered by traction motors

Autonomous battery charging mode

The engine is turned off; traction motors are operated as generators and obtained energy is used to charge the battery, Fig. 8.

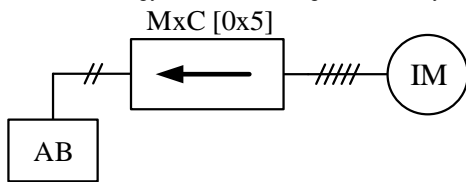

Fig. 8 Autonomous battery charging mode using traction motor IM

The virtual model of [0x5] matrix converter with fictitious DC link in indirect connection is drawn in Fig. 9.

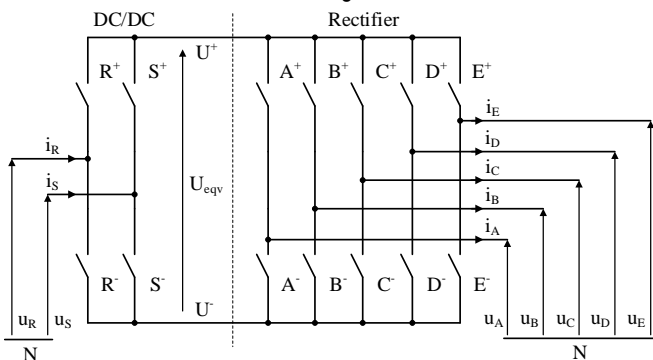

Fig. 9 Virtual model of indirect [5x0] Mx C with fictitious DC link

When modeling indirect [0x5] matrix converter we can write for output voltages

$$u_s = \frac{2}{5} (u_A + u_B e^{j\frac{2\pi}{5}} + u_C e^{j\frac{4\pi}{5}} + u_D e^{j\frac{6\pi}{5}} + u_E e^{j\frac{8\pi}{5}}) = u_\alpha + j u_\beta \quad (5)$$

where input voltages  $u_A, u_B, u_C, u_D, u_E$  can be obtained from the model of IM traction motor (already modeled in [2], [11]) which is

now operating as a generator. Then, the current flowing into/of accu-battery can be calculated using Egs. (2)-(4).

Simulation results are shown in figures Fig. 10 - Fig. 11.

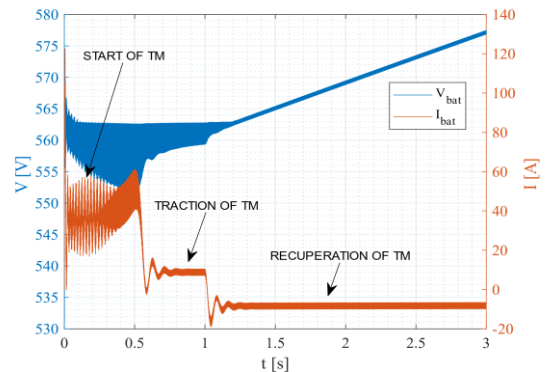

Fig. 10 The course of  $u_{AB}$  and  $i_{AB}$  during traction- and recuperation of TM braking energy

The first part of Fig. 10 represents start-up of IM traction motor. The second time interval is idle-state of IM (without the load), and the third one is the charging of accu-battery.

The same situation is shown in Fig. 11 for speed, torque and reference torque of traction motor.

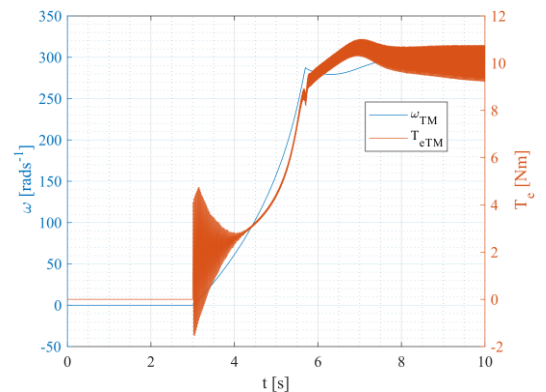

Fig. 11 Speed, torque and reference torque of synchronous generator SG during charging of accu-battery AB

As in the previous case, the first part of the figure represents the start-up of IM traction motor. The second time interval is idle-state of IM (without the load), and the third one is the charging of accu-battery.

Hybrid braking/charging mode

A similar approach can be used for the hybrid mode of HEV powertrain, Fig. 12.

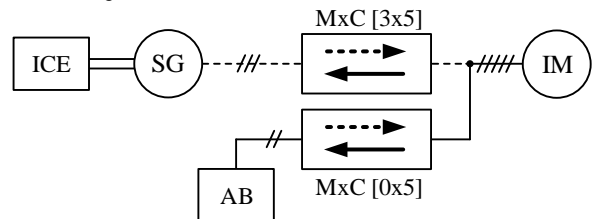

Fig. 11 Hybrid modes: motoring and/or braking of HEV

The situation is the same as above, but the engine is turned on because of hybrid mode: the energy of motor(s) is used to charge the battery and braking of ICE.

This configuration of HEV powertrain makes possible an independent control of both matrix converters: [3x5] and [0x5] MxCs. Similar simulation results as in the previous case can be obtained by this way.

## CONCLUSION

Modeling and simulation of chosen operational modes of HEV vehicle with direct AC/AC transfer and five-phase IM traction motors are given in the paper. Suggested configuration of HEV powertrain makes possible an independent control of both matrix converters [3x5] and [0x5] MxCs. An autonomous mode operation, as well as hybrid operation of HEV powertrain, are possible to solve by this way. Future works of our research group will be focused just on these hybrid operational modes.

## Acknowledgement

This work was supported by projects: APVV-15-0571 Research of the optimum energy flow control in the electric vehicle system, ITMS project No. 26210120021 co-funded from EU sources and European Regional Development Fund, and project KEGA No. 027ŽU-4/2018.

## Bibliography

1. Ehsani M., Gao Y., Emadi A., *Modern Electric, Hybrid- and Fuel Cell Vehicles*, CRC Press, Boca Raton, USA, 2010.
2. T.J. Böhme, B. Frank: *Hybrid Systems, Optimal Control, and Hybrid Vehicles: Theory, Methods and Applications*. Springer International Publishing AG, 2017, ISBN 978-3-319-51317-1 (eBook), DOI 10.1007/978-3-319-51317-1\_10, pgs. 530.
3. F.A. Wyczalek, *Hybrid electric vehicles*, Proceedings of the Energy Conversion Engineering Conference and Exhibit (IECEC) 35th Intersociety, vol.1, pp. 349-355, July 24-28, 2000.
4. Hartani K., Bourahla M., Miloud Y., Sekour M., *Electronic Differential with Direct Torque Fuzzy Control for Vehicle Propulsion System*, Turk J Elec Eng & Comp Sci, Vol.17, No.1, 2009, © TUBITAK, doi:10.3906/elk-0801-1, no. 6, pp. 21 -38.
5. Levi E., Jones M., Vukosavic S.N., Toliyat H.A., *A novel concept of a multiphase, multi-motor vector controlled drive system supplied from a single voltage source inverter*, IEEE Trans. Power Electronics, vol. 19, pp. 320-335, 2004.
6. Jones M., Levi E., Vukosavic S.N., *Independent Control of Two Five-Phase Induction Machines Connected in Parallel to a Single Inverter Supply*, 1-4244-0136-4/06/\$20.00 '2006 IEEE, pp. 1257-1262.
7. Zhang B., Bai H., Pekarek S.D., Eversman W., Krefta R., Holbrook G., Buening D., *Comparison of 3-, 5-, and 6-phase machines for automotive charging applications*, In Proc. IEEE Int. Electric Machines and Drives Conf. IEMDC, Madison, WI, 2003, CD-ROM paper 10642.
8. Rezaoui M.M., Kouzou A., Mahmoudi M.O., Nezli L., *Comparison Performances between Two Matrix Converters [3x3] and [3x5] Supplying a Multi-Phases Induction Machine*, Journal of Electrical Engineering, [www.jeee.ro](http://www.jeee.ro).
9. Dobrucký B., Záskalický P., Pavlásek P., *Control of hybrid- and electrical vehicle with five-phase IM motor*, Autobusy-Efficiency of Transport, no. 6 (), 2017, ISSN 1509-5878, pp. CD ROM.
10. Dobrucký B., Drgona P., Kaščák S., Praženica M., Pavlásek P., *Possible operation modes of HEV vehicle with direct AC/AC transfer and 5-phase traction motors*. Autobusy-Efficiency of Transport, no. 12, 2017, ISSN 1509-5878, pp. CD ROM.
11. Dobrucký B., Kaščák S., Praženica M., Pavlásek P., *Direct AC-AC Propulsion System using Matrix Converter and 5 $\Phi$ -traction motor for HEV Vehicle*, Communications-Scientific Letters of Uni of Žilina, vol. 20, no. 1, 2018, ISSN 1335-4205, pp. 4–12.
12. Sladeczek, V., J. Drapela, P. Palacky, J. Machacek, D. Slivka And P. Hudecek., *Operating Mode of Permanent Magnet Synchronous Generator*. In: 11th International Scientific Conference on Electric Power Engineering. Brno: Brno University of Technology, 2010, pp. 249–252. ISBN 978-80-214-4094-4.
13. Golubev A.N., Ignatenko S.V., *Influence of number of stator-winding phases on the noise characteristics of an asynchronous motor*, Russian Electrical Engineering, vol. 71, no. 6, 2000, pp. 41-46.

## Modeling and simulation of charging and braking regimes of AC/AC powertrain of HEV vehicle

Artykuł dotyczy modelowania i symulacji wybranych trybów operacyjnych pojazdu HEV z bezpośrednim transferem AC / AC i pięciofazowymi silnikami trakcyjnymi IM. Taka konfiguracja zapewnia mniejsze spadki napięcia w porównaniu z szeregowym przetwornikiem AC / DC / AC, a pięciofazowe maszyny oferują pewne nieodłączne zalety w stosunku do ich trójfazowych odpowiedników. Zaletami są obniżone pulsacje momentu elektromagnetycznego, a także charakterystyki szumów napędów pięciofazowych są lepsze w porównaniu z układami trójfazowymi. Systemy ładowania i hamowania zostały wybrane jako możliwe tryby operacyjne do modelowania i analiz. Symulacja. Wyniki uzyskane przy użyciu Matlab / Simulink podane są w pracy.

## Authors:

Prof. **Branislav Dobrucký** – the University of Žilina – Department of Mechatronics and Electronics. He graduated from the University of Žilina in the field of Electrical Traction and Energetics. E-mail: [branislav.dobrucky@fel.uniza.sk](mailto:branislav.dobrucky@fel.uniza.sk).

Dr. **Slavomír Kaščák** – the University of Žilina – Department of Mechatronics and Electronics. He graduated from the University of Žilina in the field of Power Electronic System. E-mail: [peter.drgona@fel.uniza.sk](mailto:peter.drgona@fel.uniza.sk).

Dr. **Michal Praženica** – the University of Žilina – Department of Mechatronics and Electronics. He graduated from the University of Žilina in the field of Power Electronic System. E-mail: [prazenica@fel.uniza.sk](mailto:prazenica@fel.uniza.sk).

Assoc. Prof. **Peter Drgoňa** – the University of Žilina – Head of Department of Mechatronics and Electronics. He graduated from the University of Žilina in the field of Power Electronic System. E-mail: [peter.drgona@fel.uniza.sk](mailto:peter.drgona@fel.uniza.sk)