

Endoscopy in automotive technology – chosen aspects

Dariusz Woźniak, Leon Kukielka, Jacek Woźniak, Joanna Woźniak

Abstract

This article presents an outline of the subject matter connected with nondestructive testing in various fields of technology, this including motorization. The basic methods of nondestructive testing are presented: visual, magnetic-powder, eddy currents, penetrative, radiological, ultrasonic. Further reference is made to the endoscopy technologies used in automotive technology, based on chosen examples of research. The article is accompanied by various photographs connected with its content.

Keywords: nondestructive methods, endoscopes, automotive technology, internal-combustion engines.

Introduction

The basic assumption of fault detection and isolation [1,3] is assessing the condition of the analyzed object, this including army equipment, without interference into its construction and mutual connections. Hence, diagnostics is treated as a field of science concerned with e.g. analyzing the condition of various objects, equipment, machinery etc. with the usage of methods which are considered nondestructive.

Such a name faithfully mirrors the research methods used, the test does not cause an object's destruction and its actual condition, despite carrying out the test, does not change. Diagnostic testing is used in technology [5], in all fields where it is impossible to dismantle the respective subassembly elements, where damaging the structure of a unit may lead to e.g. premature wear of the cooperating parts and, finally, when the dismantled parts and carrying out the so-called full dismantle and trying to make a full assessment of the technical condition or the causes of the malfunction of the cooperating parts, is too expensive and too time-consuming and the effect does not tell much or tells nothing at all.

Also in the exploitation of vehicles, especially their subassemblies, e.g. internal-combustion engines, it is common practice to introduce new diagnostic methods.

One of such methods is endoscopy which was previously used only in medicine, and which is currently becoming the basic tool for assessing technical condition and diagnostics of car equipment.

The beginning of the methods using endoscopy is thought to be the beginning of the 19th century. The first endoscopes were pipes, with which candle light or kerosene lamp light (or from any similar source) was led inside with the assistance of a mirror. There was a turning point at the end of the 19th century,

when an endoscope with an optical system of image transfer and electric light inside, was introduced.

The name *endoscope* comes from *endo* – which in Greek means *inside*, and from *scope* from the Greek *skopeo* (*I look*). Such a name was given to a thin optical instrument which was put inside an object through natural or artificially made holes, enabling visual inspection of the inside of this object. Therefore, an endoscope can be defined as a type of a speculum with its own source of light, used for conducting endoscopic research.

1. The division and characteristics of nondestructive methods

1.1. Visual Testing

A visual test [1,2,9] can be defined as an activity in which one locates and assesses the surface characteristics of an object, such as: discontinuities, deformations, the overall surface condition, with the naked eye or by using optical, optoelectronic or measuring instruments etc.

A full cycle of visual testing consists of familiarizing oneself with the analyzed object and with the quality requirements, preparation of the surface for testing, selecting the appropriate method/equipment, checking the testing equipment, carrying out the test, and preparing a report.

A large scope of the usage of this technology often carries the necessity of using additional equipment. Therefore, visual testing can be divided into:

- direct visual testing
- remote visual testing.

The aim of such testing is mainly the assessment of the surface condition (e.g. corrosion, erosion or cracks), controlling

any deviations in shape, the connections (especially the welded ones), and, finally, controlling the object after its repair.

Direct visual testing is testing which is carried out on surfaces which are directly accessible, and which is carried out with the assistance of the naked eye or with special microscopes.

Visual testing is most often carried out with the usage of specialist optical equipment, allowing for the examination of surfaces which are not easily accessible. Many defects, such as cracks, scratches or damage of parts of complicated devices, is directly assessed or may be stored on data storage devices and assessed under laboratory conditions. Examples of equipment which can be used in such testing are: pen microscopes, magnifying glasses, mirrors, stiff endoscopes (borescopes), flexible endoscopes (fibrosopes), videoendoscopes, television sets, sources of visible and ultraviolet radiation, systems of result imaging (cameras, computers), special equipment and patterns for definition testing.

Specialist optical equipment, such as borescopes, fibrosopes or videoendoscopes with full digital recording and options allowing for choosing various lightning systems, is used most often for testing such as: revision of pressure tanks, pipelines, engines, compressors and valves.

Endoscopic testing is used in e.g. the following cases:

- during the control of inaccessible inner surfaces in the production and exploitation phase,
- during the control of machine elements without dismantling the machine,
- during the control of the course of work processes, e.g. burning.

They are widely used in testing the condition of technical devices used by man to detect damage, which may cause the destruction of such devices.

They are quite important in the rocket, aviation, chemical, petroleum, armaments, nuclear energy, conventional energy, ship, railroad industries, as well as in building roads, bridges and tunnels and in other fields, especially those where there is risk for human life and its surroundings.

Visual methods can be described as being quite easy to carry out and relatively cheap. One of the more important methods of assessing a product's condition is inspecting it visually, however, in many cases, such assessment is quite difficult due to the location of the controlled parts and the inability to properly inspect with one's naked eye from all positions.

In many cases, it is virtually impossible to analyze an element with the naked eye without disassembling the entire object. Examples here include assessing the cylinder head and the valves or assessing the closed steel sections of the chassis. With only simple means, which may enable to look into the places which are difficult to access, one can significantly improve the quality of the given inspection. A typical example of assessing technical condition is assessing the technical condition of a cylinder head. The verification and inspection without dismantling this part of the engine are virtually impossible, as is the verification of the condition, and

making the decision about any repairs is connected with a high risk coming from the lack of other reliable diagnostic methods – also despite the fact that, within the service-repair process, the common assessment methods of analyzing cylinder tightness are used: air tightness test, measuring and assessing compression pressure, measuring and assessing suction in the suction manifold.

These methods, regardless of their high usefulness and reliability, only allow for assessing the condition of the elements in an indirect way and only direct – visual – assessment of the elements will allow to resolve any doubts.

1.2. The MT (Magnetic Particle) testing

Magnetic testing [1,2,9] is a type of nondestructive testing allowing for identifying surface irregularities, as well as relatively big sub-surface irregularities close to the surface, and they are used during receipt, production, final control and maintenance, for the entire surface or only locally.

They allow for discovering defects in plastic, welded, raw or already processed materials. They are also used during controlling parts of elements of different shapes and sizes which are made of ferromagnetic materials.

The choice of the system of testing: way of magnetization, detecting the magnetic field and demagnetization of objects depends on various factors, e.g.: the type of the analyzed element (material, surface condition) and the current conditions (temperature).

1.3. ET Electromagnetic/Eddy Current testing

Eddy Current testing [1,2,9] is currently the least known nondestructive testing method from amongst the six basic ones. Eddy currents are used in several basic industry sectors divided into the following groups: aviation, machine industry, iron and steel industry, heat-exchanger testing and joint testing.

The Eddy Current testing is a surface method. In this case, only metal products can be tested, up to the depth of between a few and above ten millimeters. However, the high sensitivity of this method and the result credibility has put this method in a very important position in methods used in industries such as the aviation, nuclear, chemical or machine industries. A method of this type is about creating a changeable electromagnetic field within the given material and receiving the reaction of the material by a test probe and Eddy Current defectoscope. The analysis of the changes in the electromagnetic field, the amplitude and the phase shift of the tension and strength, allows for a very precise assessment of the condition of the tested material, the occurring irregularities in the form of e.g. cracks, erosive defects or corrosion, assessing their size and depth.

This method allows to identify cracks in elements of aviation constructions, parts of machines and joints. It is commonly used to test heat-exchanger pipes in nuclear and conventional power plants, in the chemical, refinery, sugar, paper and food industries. During testing the uniformity of the pipes, the losses in the thickness of the walls due to erosion or corrosion is

measured, or the presence of a foreign metal, perforations, and any cracks, are located.

Testing in the form of automated lines is carried out in technological routes producing ball bearings and various other major-scale production elements (bolts, vales, pistons, connecting rods, car hubs), where the structure is analyzed on the principle in which one compares the hardness with sample balls or other elements serving as reference. Rods, pipes and wires undergo testing with Eddy Currents in order to identify structural irregularities, cracks, lapping, longitudinal welds, foreign metals, or any changes in diameter.

The quickness of testing of up to a few meters per second, full registration of the indications, precise localization and marking during testing are a noteworthy convenience for the producer and guarantee very high quality, which is expected by the customers.

Another classic example of using the ET method is testing the plating of planes in welded places, in riveted or screwed links, identifying cracks in multi-layer constructions of composite metal materials, testing movable parts.

Eddy currents are extensively used in devices for assessing material structures, hardness testing and testing the defects of heat treating. They function here as a means of measuring hardness, estimating the content of ferrite, depth of carbonated, nitrated, structural layers, e.g. heat changes caused by thunderstorms on planes or the process of polishing machine parts.

1.4. PT testing (Liquid Penetrant)

Penetration testing [1,2,9] is a type of nondestructive testing quite frequently used in industry practice. They allow to identify surface irregularities such as: cracks, lapping, delamination, no-welds, porosity, leaks and other open irregularities on the surface.

These methods are used during receipt, production, final control or conservation, for the entire surface or only locally. They enable to identify defects in nonporous materials, parts or molded products, plastically shaped, welded, soldered, raw or already processed products.

They are also used for controlling parts of connected elements of various shapes and sizes made from ferromagnetic and non-ferromagnetic materials, which cannot be tested with the magnetic method.

The choice of testing system: the penetrant, remover, fixative, depends on a range of factors, mainly on the type of the tested element, the material used, the surface condition, the overall conditions, e.g. the temperature, and on the assumed sensitivity of the testing.

In the case of penetration testing, the most often used types of penetrants are colored (red) or fluorescent penetrants (Fig. 1 [9]). If a fluorescent is used, in order to cause fluorescence, and thus revealing surface irregularities in the given material, ultraviolet lamps are used.



Fig.1. Various types of penetrants

1.5. RT (Radiographic) testing

Radiographic testing is considered to be a method ensuring the highest credibility and it is still commonly used despite relatively high costs, and its main focus are practically all branches concerning the manufacture and exploitation of technical devices.

The basic branches of industry and production, where this method is most often used, are: welding, molding and plastic working, in such branches of industry such as the shipyard, chemical, petrochemical, car, aviation, space industries. Radiography ensures that one can acquire an image of the object on a radiographic plate or in digital form.

The objects which can be tested are products made of various materials, such as steel, ceramics, wood, gum, synthetics, concrete. Depending on the gamma ray or X-ray sources used, we may X-ray objects from 0 to a few hundred millimeters thick in steel or concrete. The sensitivity of this method ranges from a few percent in the thickness of the X-rayed surface and allows to identify such inner defects as cracks, porosity, contraction cavities or the presence of other materials.

The basic difficulty concerning the radiographic method is its limitation due to the ionization radiation and the requirements concerning personnel protection against this radiation, as well as the time-consuming aspects of this method – this is the most important factor indirectly influencing the growing costs of radiographic testing.

In industry, using ionization radiation to acquire a radiographic image is used e.g. in the electronic industry, with the usage of a phenomenon known as macroradiography to get enlargements of the tested elements, in aviation and machine industry to identify production and exploitation discrepancies, such as cracks, blanks, presence of other metals or non-metals and surface defects such as wrong shape or size.

Along with the increase in the thickness of the tested material and its density, various X-ray radiation sources are used (with energies ranging from a few electron volt to several mega electron volt acquired with the usage of X-ray machines, betatrons or linear particle accelerators. Artificial gamma radiation sources in the shape of the isotopes of cobalt, cesium, iridium, ytterbium or selenium are also an important part of contemporary radiography.

1.6. UT (Ultrasonic) testing

Ultrasonic testing [1,9] is a type of nondestructive testing most frequently used in industry practice. They allow to identify cracks, lapping, delamination, no-welding, porosity, leaks and other irregularities inside the tested elements.

This type of testing is most frequently used interchangeably with radiographic testing or as its supplement. It can also be used to estimate the microstructure of the material, occurring during prolonged exploitation.

They are used during receipt, production, final or periodic control during exploitation. They allow for discovering faults in non-porous materials, parts or molded products, plastically shaped, welded, soldered, raw or already processed materials.

Ultrasonic testing can be carried out manually, semi-automatically, or fully automatically (e.g. quality control systems on production lines).

2. An outline of the development of endoscopic technology

The first attempts at constructing the endoscope did not foresee a quick development of this diagnostic method. The device, with which one attained visibility, was first built in the year 1853, but the alcohol-turpentine lamp which was used by Antonin J. Desormeaux, who is considered to be the creator of endoscopy, was too weak for the device to be of any help to doctors in their everyday practice.

This problem was solved by Max Nitze, who, as the source of light, used a covered platinum spiral of the Edison type cooled with water. The so-called stiff endoscopes get their name from this case – these are metal pipes with a lens, eyepiece and a number of lenses inside.

2.1. The stiff borescope

A constructional turning point began with the new conception of endoscopy after constructing the flexible fibroscope [9]. A beam of optical fibers was used for transmitting images in the year 1928 by John Logie Baird and it was introduced into clinical testing by Basil Hirschowitz in 1957. Intensive development of this method occurred in the 1970s.

In a fibroscope, the beam of ideally parallel optical fibers divided an object's image into as many pixels of different color and brightness, as there are many optical fibers.

The fibroscopes used currently include thousands of optical fibers 8-1 micrometers in diameter, despite the fact that the image granulation and limited definition make the testing more difficult. However, this does not change the fact that the flexible fibroscope is very useful, since it reaches where a classical stiff

endoscope does not and allows for various manipulations in different nooks and testing spheres.

Videoendoscopy is the newest technical solution – instead of a beam of optical fibers, one uses a miniature TV camera which is put on the end of the cable. The main advantage of this method is the high quality of the image – as of today, one has already achieved the resolution of a few hundred thousand pixels – a few times more than for regular optical fibers. In addition, the device, due to its bigger mechanical resistance, is much more durable. Systems based on LED type diodes are produced for lightning systems. The viewed image can be stored and played many times through appropriate computer software.

3. Types and use of endoscopes in technology

As it was mentioned before, the first stiff endoscopes, the so-called borescopes, consisted of a stiff pipe, inside which a set of lens with in a probe was put, at the front of the system and a profiled lens on its end [9].

The first borescope models had mini light bulbs installed as a source of light, and these light bulbs were quite often damaged inside the given object due to the difficult conditions in which a borescope is operated.

The usage of optical fibers as a light carrier for the probe has eliminated the problem. Another difficulty in working with a borescope is its stiffness because it forces the speculum to be placed in such a way that it is not obstructed by curvatures blocking the movement of the device. The field of view of a borescope has, however, constantly undergone slight enlargement, however the usage of a prism in the optical system enabled changing the direction of the view.

Borescopes with zoom and movable prism consist of a metal handle and a stainless steel pipe, they are precise optical devices, fig. 2 [9] and one has to be careful when using them and properly maintain them. The construction and operations of a stiff borescope are shown on fig. 3 [9].



Fig. 2. A general view of a borescope

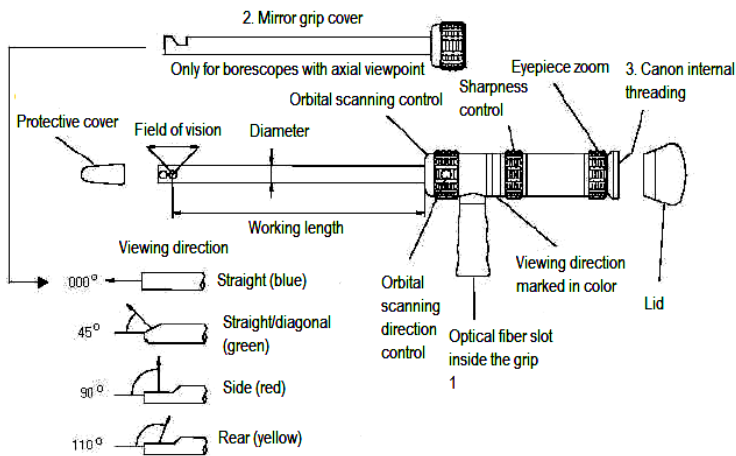

Fig. 3. The functioning of a stiff borescope

Such type of endoscope is commonly used in the power sector to inspect certain bodies: turbines, pumps, compressors or small-size containers. The successor of the stiff borescope, the so-called flexible endoscope, does not indicate the previously mentioned difficulties (thus, there are no difficulties with manipulation, stiffness and with the scope of observation).

One can generally distinguish the following types of endoscopes:

- stiff with cold light,
- stiff with hot light,
- flexible.

In an endoscope with cold light, fig. 4 [9], the light is brought into the object from a halogen projector of a specific strength with an optical fiber, and the light reflected from the object returns through the second cable back to the eyepiece.

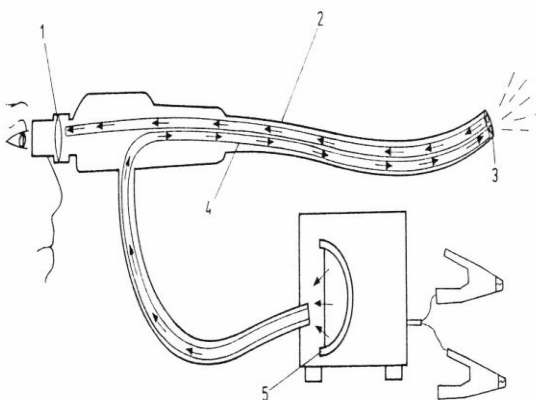

Fig. 4. The functioning of a flexible endoscope with cold light: 1- eyepiece, 2- lid, 3- lens, 4- optical fiber, 5- projector

Comparing the constructional solutions used in endoscopes, one can identify both their advantages and disadvantages. Therefore, an endoscope with hot light has its light bulb at the end of the lens, and because of this fact its price is lower, and

its disadvantage is that it cannot be used in places which are sensitive to heat (e.g. in a fuel, oil, gas tank) since the end of the endoscope emits heat.

A flexible endoscope, on the other hand, offers the ability to move the end of the endoscope with the lens up to the angle of 90° in all directions, it indeed has a broader usage than a stiff endoscope. Its only limitation is that, depending on the equipment and software, the price is quite high. An example of such a device is given below.

In automotive technology, endoscopes can be used not only for inspecting the inside of an engine [2,5,8], but also for identifying places of corrosion [6] in closed profiles of the chassis and the fuel tank, checking the wear of the cogwheels in the gearbox, for the inspection places difficult to access (e.g. VIN numbers) and other. An example of such an endoscope set is given in fig. 5 [9].

3.1. An optical inspection set for an auto appraiser (variant)

An example of equipment for such a set:

- an endoscope with a diameter of Ø 6 mm, working length 320 mm, 12V halogen light bulb lighting,
- 120° angle adapter, 120 mm in length,
- a 5m cable connection, connecting the endoscope with a typical 12 V car lighter,
- a precise borescope powered by 3,5 V voltage for the inspection of cracks of a hair's thickness,
- battery grip for 3,5 V devices,
- a cable connecting the battery grip with a 3,5 V device,
- a spot lighted head with 10x zoom for analyzing a given surface,
- a universal measuring scale (vertical, horizontal and angular),
- a light probe with a diameter of Ø 5 mm, working length 400 mm, 3,5 V with head and mirror Ø 30 mm,
- a transport case with special profiles and compartments,
- a spare light bulb for each of the four devices.



Fig. 5. A complete endoscope set

Such a set can be used for assessing technical condition and internal inspections of engines, gearboxes, closed profiles etc.

4. Control of engine conservation with endoscope technology

New diagnostic testing methods are being introduced in the exploitation and control of internal combustion engines [4,6,8]. One of these methods is the previously mentioned endoscopy which is a practical tool for assessing the condition of internal combustion engines, with the possibility of assessing e.g. the condition of the conservation inside such an engine.

In such a case, one of the options for getting a diagnosis about an engine's technical condition is endoscopy with the usage of endoscopes. In a non-invasive way, which is also quite quick and cheap, and, most importantly, unambiguous, any doubts are resolved, e.g. those of an auto appraiser or a diagnostician.

In order to carry out a simplified analysis [9] of the conservation state of various internal elements of an engine and their visualization, the authors have used a Milwaukee M12 endoscope camera.

The length of an elastic optical fiber, which has a flexible end allowing for observation in any direction, is 914 mm. It has replaceable ends which allow for the observation of front and side sectors. Due to this, the manual possibilities of observation are far greater during internal inspection of car engine parts.

Car engine endoscope testing is quite frequently done, especially in the following situations [9]:

- during planning-prevention check-ups,
- during current assessment of an engine's technical condition, when there is a necessity for e.g. prolonging the inter-repair period or the target exploitation norm,
- a higher noise, vibration level, or the presence of metal fillings in the oil,
- excessive smoke,
- assessing the scope and causes of breakdowns etc.

A S-359 type engine for the Star 200/266 vehicle has been assessed for the technical condition, after a 3-year storage period, the engine after protection removal [7] was supposed to be changed in the vehicle. External and organoleptic inspection after the protection removal did not indicate a loss in quality parameters, traces of exfoliations etc.

However, during the final stage of the inspection, after inserting the optical fiber head into the water collector pipe, an image of strong internal corrosion could be seen on the camera screen [6], which was of a sport nature, fig. 6 [9], covering virtually the entire pipe, fig. 7 [9].

With this type of testing, both the internal and external structure of the construction material [2] is visible during the testing like through a magnifying glass, appropriately enlarged, which enables quick identification, recognition and potential assessment of the occurring defects or material faults.



Fig. 6. A view of the inside of a pipe



Fig. 7. A view of the end of a pipe

4.1. The basic technical characteristics of an inspection Milwaukee C12 camera

Technical specifications:

- color LCD 60mm/2,4" screen,
- digital zoom of up to 200%,
- 17 mm waterproof camera head with a 3-level LED light enabling optimal visibility,
- waterproof 900mm-long cable,
- an ergonomic grip enabling full rotation angle,
- 12V lithium-ion batteries,
- battery charging time up to 30 minutes,
- voltage/capacity 12V/1,5 Ah Li-Ion,
- screen size 2,4",
- display resolution 320 x 240 pixels,
- optical fiber cable length 914 mm,
- work time on charged battery 15 h,
- weight of complete set in suitcase 0,82 kg.

5. Conclusions

Precise observation and analysis of an image with endoscopic technology has very interesting advantages, since it does not require the dismantling of the analyzed object into smaller parts, and the equipment used does not in any way influence this object. What is more, the results allow for the early identification of any damage and periodical observation of the advancing wearing, or malfunctions of a given subassembly.

The main influence of this is that this method became one of the basic nondestructive methods which are being used in various fields of technology, this including automotive technology. This is justified both from the economical and technical point of view, since it shortens the time needed for identifying the current technical condition of army equipment, reduces the costs of its usage and improves exploitation safety.

What is also important when using this method, is the knowledge of the construction and purpose of the analyzed objects – it may sometimes happen that the diagnosis/assessment of the technical condition is erroneous.

Good knowledge of a given object's construction is a guarantor of preventing an erroneous diagnosis, e.g. attributing a scratch or streak to a solidified spot of oil as a crack.

The above observations confirm that not only the ability to operate modern measuring equipment is important in endoscopic testing. The ability to correctly interpret the obtained results is also important in this case.

The possibility and scope of using an endoscope depends on the constructional solutions used within a given vehicle or machine. The body shells do not have technological holes which always makes the user dismantle some of the subassemblies or elements (e.g. fuel injection or pre-combustion chambers). Such activities make the testing last longer, makes it more expensive

and creates the risk of damaging the dismantled elements or the entire object, thus making further exploitation impossible.

It is also advisable that the time of the check-ups be correlated with the conservation plans for a given object.

Bibliography

1. Lewińska-Romicka A., *Nondestructive testing. The basics of defectoscopy*. WNT, Warsaw, 2001.
2. Deputat J., *Nondestructive methods of testing properties of materials*. Biuro Gamma, Warszawa 1997.
3. Woźniak D., *Script – Servicing and repairs of army devices and equipment. Assumptions, scope, organization*. Addition to PWL no 6/2011 (031). Wydawnictwo WIW, Warsaw, 2011. CD.
4. Woźniak D., Kukielka L., *Cavitation in light of durability and technical efficiency of vehicles*. XII Science-technology Conference. Wydawnictwo RRFS NOT – Słupsk, 2009.
5. Woźniak D., Woźniak J., Kukielka L., *Breakdowns and exploitation wear of vehicles*. XI Science-technology Conference. Wydawnictwo RRFS NOT – Słupsk, 2008.
6. Woźniak D., Kukielka L., *Corrosion in motorization and its influence on the durability of vehicles and on exploitation costs*. X Science-technology Conference. Wydawnictwo RRFS NOT – Słupsk, 2007.
7. Woźniak D., Kukielka L., *Storage and conservation of army vehicles and equipment – an outline*. X Science-technology Conference. Wydawnictwo RRFS NOT – Słupsk, 2007.
8. Woźniak D., Gawryjolek W., Kukielka L., *Assessment of the technical condition of engines after breakdowns – a methodology outline*. IX Science-technology Conference. Wydawnictwo RRFS NOT – Słupsk, 2006.
9. *The authors' own pictures and materials*.

Endoskopia w technice samochodowej – wybrane aspekty

Streszczenie

W artykule zaprezentowano zarys tematyki związany z badaniami nieniszczącymi w różnych dziedzinach techniki, w tym w motoryzacji. Przedstawiono podstawowe metody badań nieniszczących: wizualne, magnetyczno-proszkowe, prądów wirowych, penetracyjne, radiologiczne, ultradźwiękowe. Szerzej odniesiono się do technik endoskopowych wykorzystywanych w technice samochodowej w oparciu o wybrane przykłady badań. Uzupełnieniem artykułu są zdjęcia związane z treścią.

Słowa kluczowe: metody nieniszczące, endoskopy, technika samochodowa, silniki spalinowe.

Autorzy:

Mgr inż. **Dariusz WOŹNIAK** - Stowarzyszenie Rzecznawców Techniki Samochodowej i Ruchu Drogowego w Warszawie, Oddział w Koszalinie

Prof. dr hab. inż. **Leon KUKIELKA** - Politechnika Koszalińska

Mgr **Jacek WOŹNIAK** - Szczecin University

Mgr **Joanna WOŹNIAK** – Adam Mickiewicz University in Poznań